



CR2032

CompactModule Metall

E/A-Modul
digital und analog
für System R 360

CANopen Schnittstelle

Oberfläche KTL-beschichtet

10...32 V DC

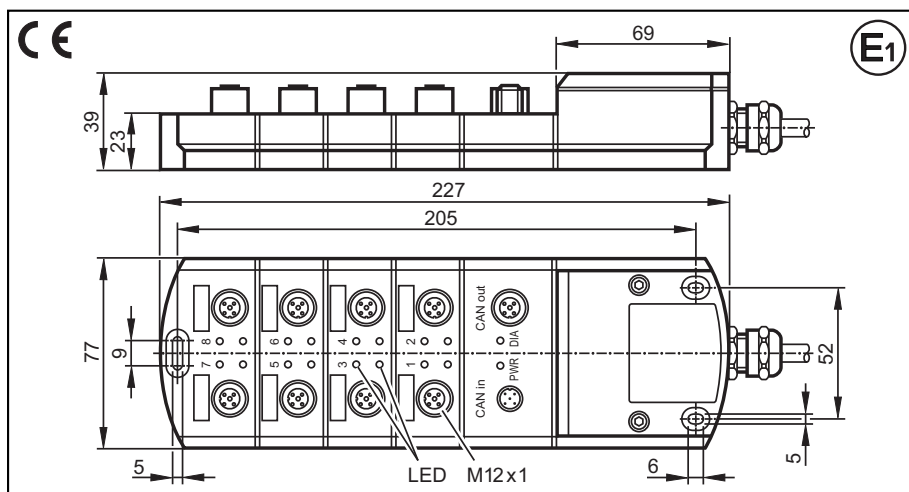

E1

Technische Daten

**8 Eingänge (4 digital und 4 analog/digital)
8 Ausgänge (4 digital und 4 digital/PWM)**

Gehäuse	8-fach Verteilergehäuse aus Zink-Druckguss mit Kabelanschlussraum Oberfläche KTL-beschichtet (kathodische Tauchlackierung), schwarz
Maße (LxBxH)	227 x 77 x 39 mm (ohne Kabelverschraubung)
Montage	Schraubbefestigung mit 3 Stk. M5 x L nach DIN 912 bzw. DIN 7984
Anschlüsse Betriebsspannung und CAN-Bus	7-pol. Klemmleiste mit CAGE CLAMP® Anschlusstechnik (Käfigzugfedern) (2 x 2-pol./1 x 3-pol.) 0,08...4 mm ² (AWG 28...AWG 12), Nennstrom 20 A Identische Potentiale mit Brückungskamm brückbar (im Lieferzustand jeweils GND- und U _B -Potentiale gebrückt) Kabeleinführung über M 16 Kabelverschraubung 8 x M 12-Steckverbinder (Buchse), 5-polig 2 x M 12-Steckverbinder (Stecker/Buchse), 5-polig
Ein-/Ausgänge CANin/CANout	
Gewicht	1,35 kg
Eingänge	8
konfigurierbar als	4 digital, plus-schaltend (High-Side) 4 analog, 0...10/32 V, 0/4...20 mA, ratiometrisch oder digital plus-schaltend, diagnosefähig
Sensorversorgung I _{max}	400 mA
Ausgänge	8
konfigurierbar als	4 digital, plus-schaltend (High-Side), diagnosefähig und 4 digital, plus-schaltend (High-Side), diagnosefähig oder PWM
Schaltstrom je Ausgang	max. 2 A
Summenstrom	max. 16 A
Betriebsspannung U _B	10...32 V DC
Stromaufnahme	≤ 60 mA (ohne externe Last bei 24 V DC)
Betriebstemperatur	-40...85 °C
Lagertemperatur	-40...85 °C
Schutzart	IP 67
Schnittstelle	CAN Interface 2.0 B, ISO 11898
Baudrate	20 kBit/s...1 MBit/s (Defaulteinstellung 125 kBit/s) (einstellbar über Drehschalter im Kabelanschlussraum, hex-codiert oder über CANopen-Objektverzeichnis)
Kommunikationsprofil	CANopen, CiA DS 301 Version 4, CiA DS 401 Version 2.1
Node-ID (Default)	hex 20 (= dez 32) (einstellbar über 2 Drehschalter im Kabelanschlussraum, hex-codiert oder über CANopen-Objektverzeichnis)
Anzeigen	1 LED grün (PWR) 1 LED rot (Diagnose, DIA) 16 LED gelb (Status der Ein-/Ausgänge)

DATEN100DB-FORM-PTZD03/12/96



CR2032

Anschluss- und Bedienelemente

Technische Daten

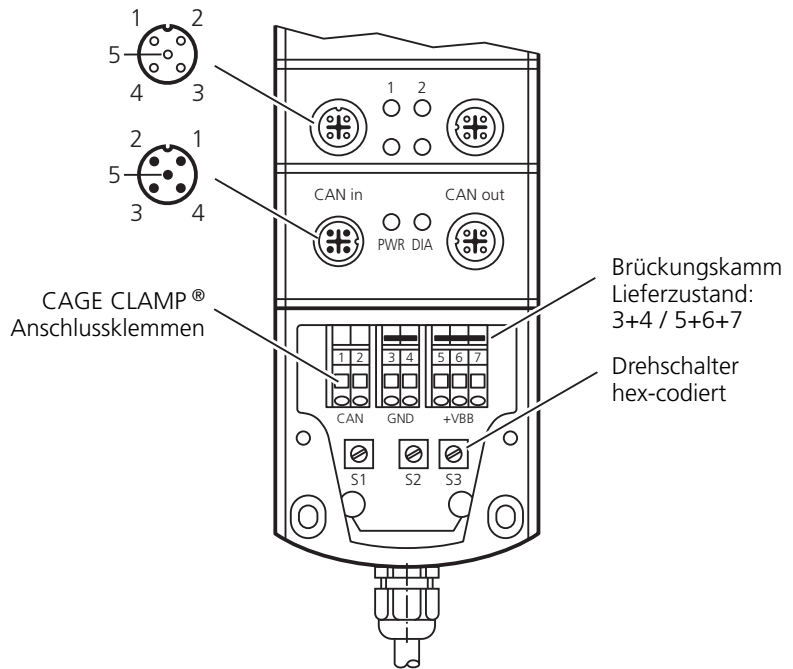

Drehschalter-Codierung

Schalter	Stellung	Beschreibung
S1 Baudrate	0	1000 kBit/s
	1	800 kBit/s
	2	500 kBit/s
	3	250 kBit/s
	4	125 kBit/s
	5	100 kBit/s
	6	50 kBit/s
	7	20 kBit/s
	8...E	nicht definiert
F	Einstellung über Objektverzeichnis (Default)	
S2 Node-ID _H	0...7	High-Nibble, z.B. 20 hex (= 32 dez)
	F	Einstellung über Objektverzeichnis (Default)
S3 Node-ID _L	0...E	Low-Nibble, z.B. 20 hex (= 32 dez)
	F	Einstellung über Objektverzeichnis (Default)



Betriebszustände (LEDs)

LED	Zustand	Beschreibung
PWR (grün)	AUS	keine Versorgungsspannung
	EIN	Modul im Stand by-Modus CANopen-Status: PREOPERATIONAL / PREPARED Ausgänge = AUS
DIA (rot)	AUS	Modul aktiv
	EIN	CANopen-Status: OPERATIONAL Ausgänge werden aktualisiert
IN (gelb)	AUS	Kommunikation ok
	EIN	Kommunikation gestört • NodeGuard-/Heartbeat-Fehler (wenn NodeGuarding/Heartbeat aktiviert ist) • keine Synch-Objekte (wenn Synch-Überwachung aktiviert ist)
OUT (gelb)	AUS	Binärer Eingang ist angesteuert
	EIN	Diagnose Fehler
OUT (gelb)	AUS	Binärer Ausgang: Ausgang ist angesteuert (EIN)
	EIN	Analoger Ausgang: PWM-Sollwert ≠ 0



CR2032

Kenndaten der Ein-/Ausgänge

Eingänge

Channel 1, 3, 5, 7 (Pin 4)

■ Digitaleingänge; diagnosefähig

Einschaltpegel 0,7 U_B
 Ausschaltpegel 0,3 U_B
 Eingangswiderstand 3,21 kΩ
 Eingangsfrequenz max. 50 Hz

Channel 1, 3, 5, 7 (Pin 2)
 konfigurierbar als ...

■ Analogeingänge

Spannung, Strom, ratiometrisch oder digital plus-schaltend

Spannungseingänge

Eingangsspannung 0...10/32 V
 Auflösung 10 bit
 Eingangswiderstand 50/30 kΩ
 Eingangsfrequenz 50 Hz
 Genauigkeit ± 1 % FS

Stromeingänge

Eingangsstrom 0/4...20 mA
 Auflösung 10 bit
 Eingangswiderstand 400 Ω
 Eingangsfrequenz 50 Hz
 Genauigkeit ± 1 % FS

Ratiometrische Eingänge für potentiometrische Geber (z.B. Joystick)

Funktion $((U_{IN} - \frac{1}{2}U_B) \div \frac{1}{2}U_B) \times 1000 \text{ ‰}$
 Wertebereich 0...1000 ‰

Digitaleingänge; diagnosefähig

Einschaltpegel 0,7 U_B
 Ausschaltpegel 0,4 U_B
 Eingangswiderstand 30 kΩ
 Eingangsfrequenz max. 50 Hz

Ausgänge

Channel 2, 4, 6, 8 (Pin 4)
 konfigurierbar als ...

■ Halbleiterausgänge; diagnosefähig (Leitungsunterbrechung und Kurzschluss) kurzschluß- und überlastfest

Schaltspannung 10...32 V DC
 Schaltstrom max. 2 A

■ PWM-Ausgänge

PWM-Frequenz 20...250 Hz
 Tastverhältnis 0...1000 ‰
 Auflösung 1 ‰
 Schaltstrom max. 2 A (bezogen auf den PWM-Wert 1000 ‰.)

Channel 2, 4, 6, 8 (Pin 2)
 konfigurierbar als ...

■ Halbleiterausgänge; diagnosefähig (Leitungsunterbrechung und Kurzschluss) kurzschluß- und überlastfest

Schaltspannung 10...32 V DC
 Schaltstrom max. 2 A

Hinweis

siehe auch Anschlussbelegung (Folgeseite)

Prüfnormen und Bestimmungen

Klimatest

Feuchte/Wärme nach EN 60068-2-30, Test Db
 (≤ 95% rel. Luftfeuchtigkeit, nicht kondensierend)
 Salznebelprüftest nach EN 60068-2-52, Test Kb, Schärfegrad 3
 Schutzartprüfung nach EN 60529

Mechanische Festigkeit

Schwingen nach EN 60068-2-6, Test Fc
 Schocken nach EN 60068-2-27, Test Ea
 Schocken im Betrieb nach EN 60068-2-29, Test Eb

Störfestigkeit gegen leitungsgebundene Störungen

nach ISO 7637-2: 2004, Impulse 2a, 3a, 3b, 4, Schärfegrad 4, Funktionszustand A
 nach ISO 7637-2: 2004, Impuls 1, 2b, Schärfegrad 4, Funktionszustand C
 nach ISO 7637-2: 2004, Impuls 5, Schärfegrad 1, Funktionszustand A

Störfestigkeit gegen Fremdfeld

gemäß UN/ECE-R10 mit 100 V/m (E1-Typgenehmigung)
 und DIN EN 61000-6-2 (CE)

Störabstrahlung

gemäß UN/ECE-R10 (E1-Typgenehmigung)
 und DIN EN 61000-6-3 (CE)

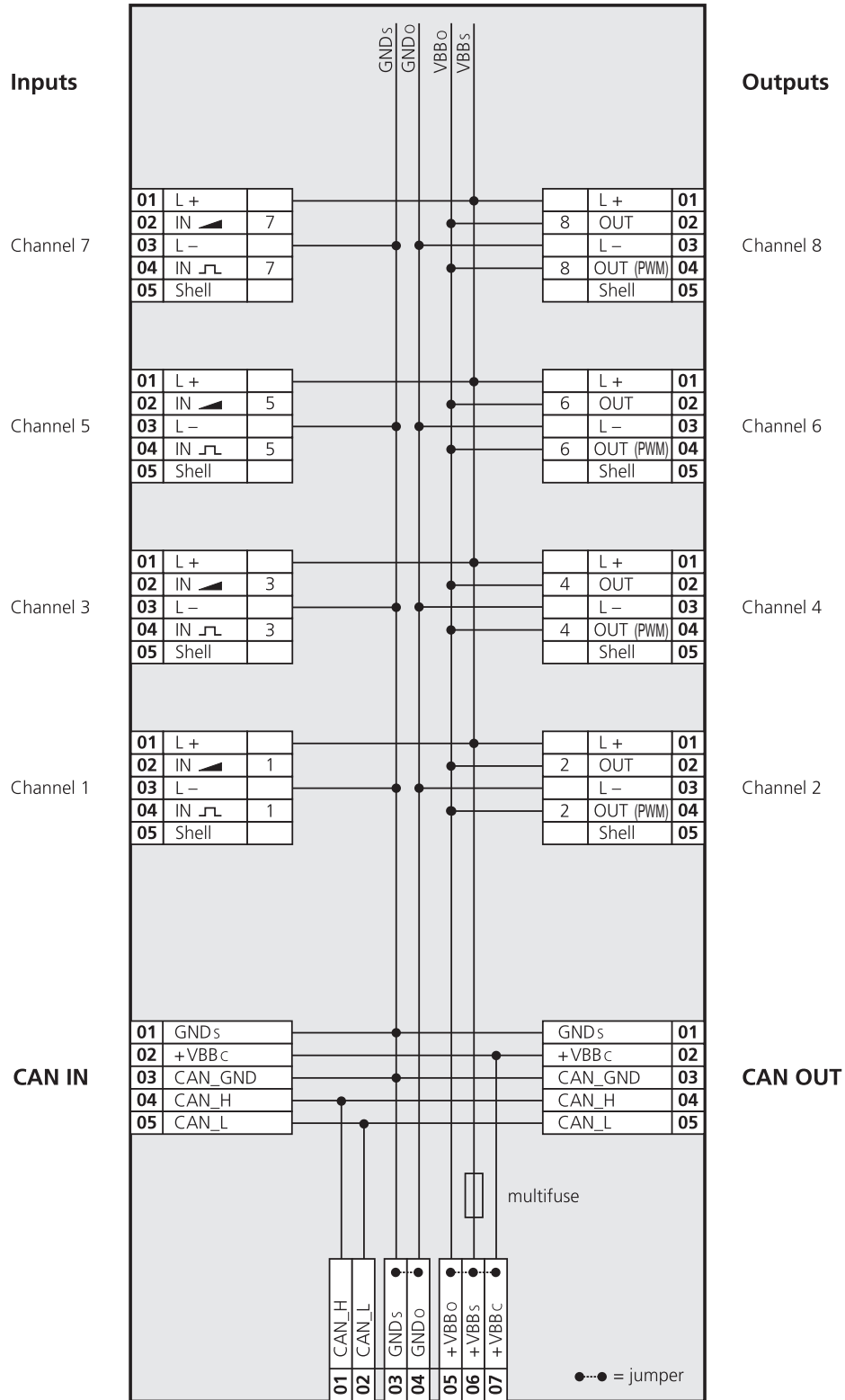

CAN Interface / Supply

Abkürzungen

















CAN_H = CAN-Schnittstelle (High)
 CAN_L = CAN-Schnittstelle (Low)
 GND_O = Ground (Output)
 GND_S = Ground (Modul)

PWM = Ausgang für Puls-weiten-modulierte Signale
 VBB_C = Betriebsspannung (über Stecker CANin/CANout)
 VBB_O = Betriebsspannung (Output)
 VBB_S = Betriebsspannung (Modul)



CR2032

Zuordnung der LEDs zu den Anschlüssen

CODESYS 2.3 PLC Configuration		Input		Output		CODESYS 2.3 PLC Configuration	
binary inputs	Channel # LED	Pin	Pin	Channel # LED	binary outputs	analogue outputs	
	7			8			
chan 4		2	4		Bit 3	chan 4	
chan 4		4	2		Bit 7		
	5			6			
chan 3		2	4		Bit 2	chan 3	
chan 3		4	2		Bit 6		
	3			4			
chan 2		2	4		Bit 1	chan 2	
chan 2		4	2		Bit 5		
	1			2			
chan 1		2	4		Bit 0	chan 1	
chan 1		4	2		Bit 4		



CR2032

CompactModule Metal

I/O module
digital and analogue
for R360 system

CANopen interface

Surface electrostatically
coated (cathodic immersion)

10...32V DC

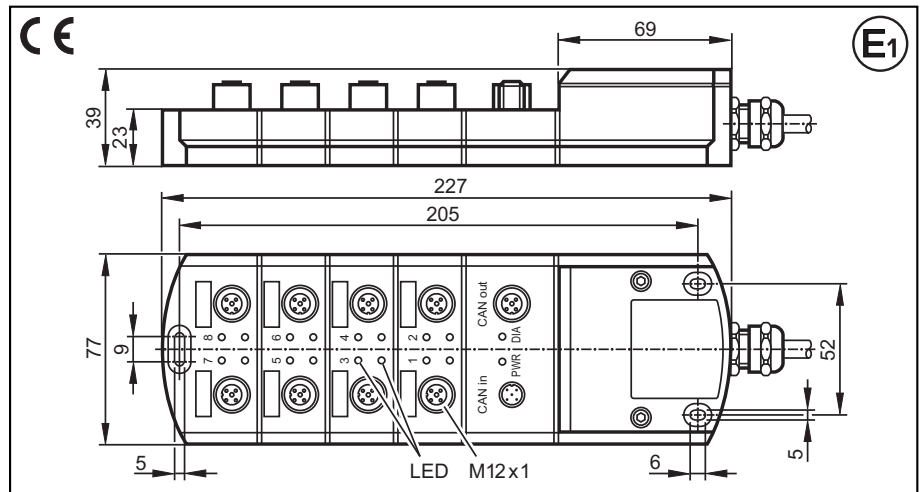

Technical data

**8 inputs (4 digital and 4 analogue/digital)
8 outputs (4 digital and 4 digital/PWM)**

Housing	Die-cast zinc housing with 8 outputs and terminal chamber surface electrostatically coated (cathodic immersion), black
Dimensions (l x w x h)	227 x 77 x 39 mm (without cable gland)
Installation	Screw connection by means of 3 M5 x l screws to DIN 912 or DIN 7984
Connections Operating voltage and CAN bus	7-pole terminal strip with CAGE CLAMP® connection technology (2 x 2-pole / 1 x 3-pole) 0.08...4 mm ² (AWG 28...AWG 12), nominal current 20 A Identical potentials can be linked using a jumper header (GND and U _B potentials linked upon delivery) Cable entry via M16 cable gland 8 x M12 connector (socket), 5-pole 2 x M12 connector (plug/socket), 5-pole
Inputs/Outputs CANin/CANout	
Weight	1.35 kg
Inputs can be configured as	8 4 digital, positive-switching (high side) 4 analogue, 0...10/32 V, 0/4...20 mA, ratiometric or digital, positive-switching, with diagnostic capability
Sensor supply I _{max}	400 mA
Outputs can be configured as	8 4 digital, positive-switching (high side), with diagnostic capability 4 digital, positive-switching (high side), with diagnostic capability or PWM channel
switching current per output	max. 2 A
total current	max. 16 A
Operating voltage U _B	10...32 V DC
Current consumption	≤ 60 mA (without external load at 24 V DC)
Operating temperature	-40...85 °C
Storage temperature	-40...85 °C
Protection	IP 67
Interface	CAN interface 2.0 B, ISO 11898
Baud rate	20 Kbits/s...1 Mbit/s (default setting 125 Kbits/s) (adjustable using hex-code switches in the terminal chamber or via the CANopen object directory)
Communication profile	CANopen, CiA DS 301 version 4, CiA DS 401 version 2.1
Node ID (default)	hex 20 (= dec 32) (adjustable using hex-code switches in the terminal chamber or via the CANopen object directory)
Displays	1 LED green (PWR) 1 LED red (diagnosis, DIA) 16 LEDs yellow (status of the inputs / outputs)



CR2032

Connecting and operating elements

Technical data

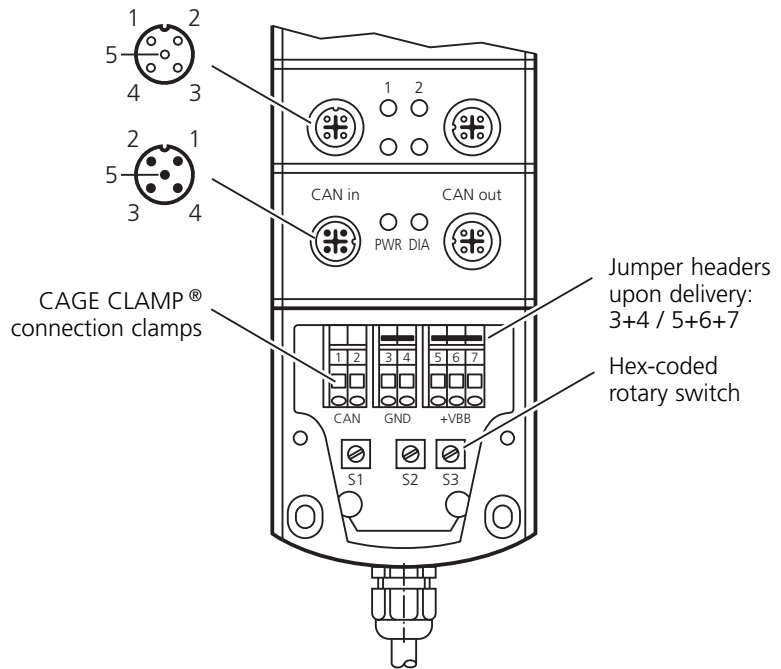

Hex-code switch coding

Switch	Position	Description
S1 Baud rate	0	1000 Kbits/s
	1	800 Kbits/s
	2	500 Kbits/s
	3	250 Kbits/s
	4	125 Kbits/s
	5	100 Kbits/s
	6	50 Kbits/s
	7	20 Kbits/s
	8...E	not defined
	F	adjustment via object directory (default)
S2 Node ID _H	0...7	high nibble, e.g. 20 hex (= 32 dec)
	F	adjustment via object directory (default)
S3 Node ID _L	0...E	low nibble, e.g. 20 hex (= 32 dec)
	F	adjustment via object directory (default)



Operating states (LEDs)

LED	Status	Description
PWR (green)	OFF	no supply voltage
	ON	module in stand-by mode
	2.0 Hz	CANopen status: PREOPERATIONAL / PREPARED
		outputs = OFF
DIA (red)	OFF	module active
	ON	CANopen status: OPERATIONAL
		outputs are updated
IN (yellow)	OFF	communication OK
	ON	communication disturbed
OUT (yellow)	OFF	• node guard / heartbeat error (if node guarding / heartbeat is activated)
	ON	• no synch objects (if synch monitoring is activated)
IN (yellow)	ON	binary output switched
	2.0 Hz	diagnosis failure
OUT (yellow)	ON	binary output: output switched (ON)
		analogue output: PWM preset value ≠ 0



CR2032

Characteristics of the inputs / outputs

Inputs

Channel 1, 3, 5, 7 (pin 4)

- Digital inputs, with diagnostic capability
- Switch-on level 0.7 U_B
- Switch-off level 0.3 U_B
- Input resistance 3.21 kΩ
- Input frequency max. 50 Hz

Channel 1, 3, 5, 7 (pin 2)
can be configured as ...

- Analogue inputs
voltage, current, ratiometric or digital positive-switching

- Voltage inputs
- Input voltage 0...10/32 V
- Resolution 10 bits
- Input resistance 50/30 kΩ
- Input frequency 50 Hz
- Accuracy ± 1 % FS

- Current inputs
- Input current 0/4...20 mA
- Resolution 10 bits
- Input resistance 400 Ω
- Input frequency 50 Hz
- Accuracy ± 1 % FS

- Ratiometric inputs for potentiometric transducers (e.g. joystick)
- Function $((U_{IN} - \frac{1}{2}U_B) \div \frac{1}{2}U_B) \times 1000 \text{ ‰}$
- Value range 0...1000 ‰

- Digital inputs, with diagnostic capability
- Switch-on level 0.7 U_B
- Switch-off level 0.4 U_B
- Input resistance 30 kΩ
- Input frequency max. 50 Hz

Outputs

Channel 2, 4, 6, 8 (pin 4)
can be configured as ...

- Semiconductor outputs, with diagnostic capability (wire break and short circuit)
short-circuit and overload protected
- Switching voltage 10...32 V DC
- Switching current max. 2 A

- PWM outputs
- PWM frequency 20...250 Hz
- Pulse duty factor 0...1000 ‰
- Resolution 1 ‰
- Switching current max. 2 A (referred to PWM value 1000 ‰.)

Channel 2, 4, 6, 8 (pin 2)
can be configured as ...

- Semiconductor outputs, with diagnostic capability (wire break and short circuit)
short-circuit and overload protected
- Switching voltage 10...32 V DC
- Switching current max. 2 A

Note

also see wiring (following page)

Test standards and regulations

Climatic test

Damp heat to EN 60068-2-30, test Db
(≤ 95% rel. humidity, non-condensing)
Salt mist test to EN 60068-2-52, test Kb, severity level 3
Protection test to EN 60529

Mechanical resistance

Vibration to EN 60068-2-6, test Fc
Shock to EN 60068-2-27, test Ea
Bump to EN 60068-2-29, test Eb

Immunity
to conducted interference

to ISO 7637-2: 2004, pulses 2a, 3a, 3b, 4, severity level 4, function state A
to ISO 7637-2: 2004, pulse 1, 2b, severity level 4, function state C
to ISO 7637-2: 2004, pulse 5, severity level 1, function state A

Immunity
to interfering fields

according to UN/ECE-R10 at 100 V/m (E1 type approval)
and DIN EN 61000-6-2 (CE)

Interference emission

according to UN/ECE-R10 (E1 type approval)
and DIN EN 61000-6-3 (CE)

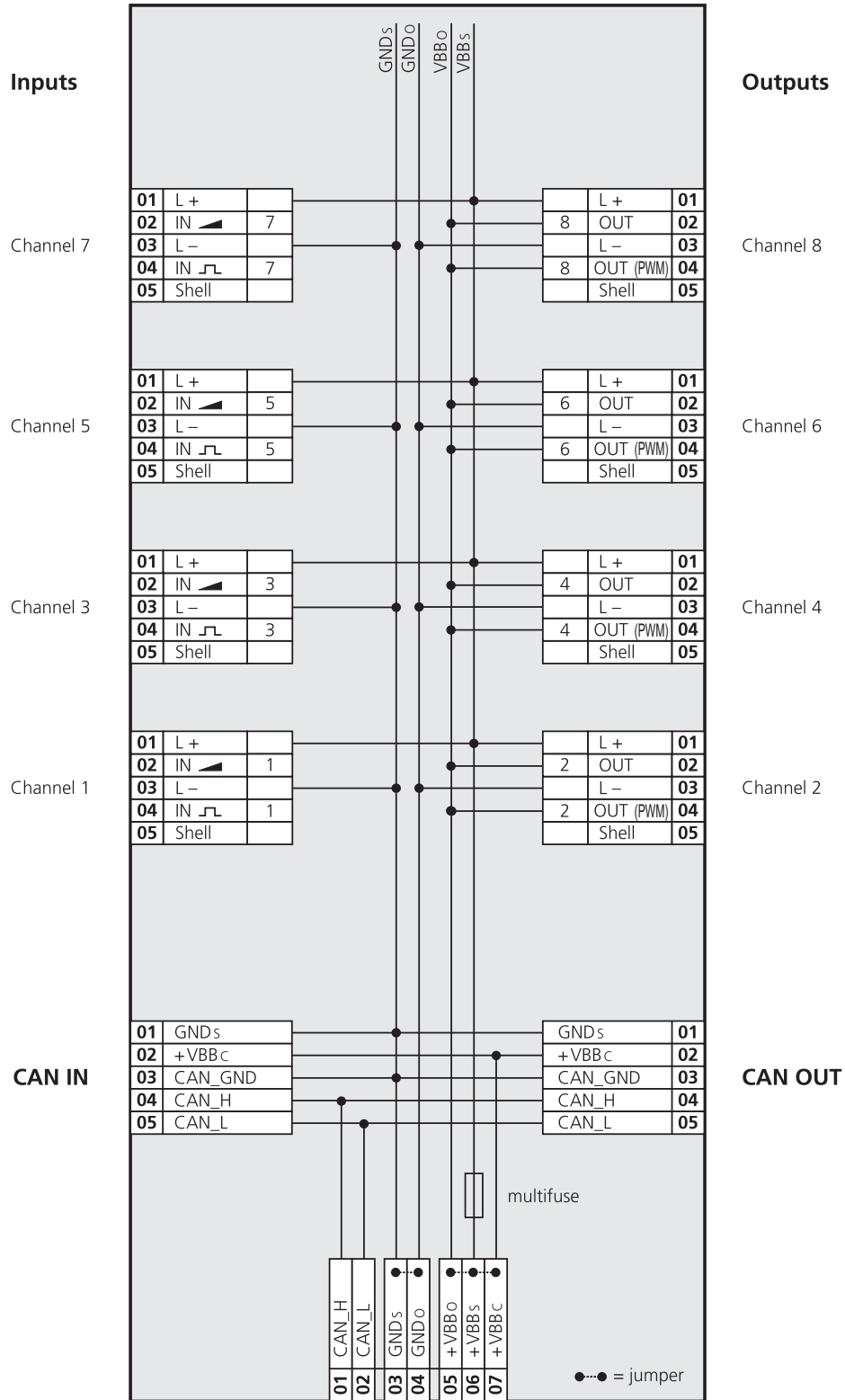

CAN Interface / Supply

Abbreviations

CAN_H = CAN interface (high)
 CAN_L = CAN interface (low)
 GND_o = ground (output)
 GND_s = ground (module)

PWM = output for pulse-width modulated signals
 VBB_c = operating voltage (via CANin/CANout plug)
 VBB_o = operating voltage (output)
 VBB_s = operating voltage (module)



CODESYS 2.3 PLC Configuration		Input		Output		CODESYS 2.3 PLC Configuration	
binary inputs	Channel # LED	Pin	Pin	Channel # LED	binary outputs	analogue outputs	
chan 4		7	2	8		Bit 3	chan 4
		4	4			Bit 7	
chan 3		5	2	6		Bit 2	chan 3
		4	4			Bit 6	
chan 2		3	2	4		Bit 1	chan 2
		4	4			Bit 5	
chan 1		1	2	2		Bit 0	chan 1
		4	4			Bit 4	



CR2032

Modules compacts métalliques

Module E/S TOR et analogique pour le système R 360

Interface CANopen

Peinture en immersion pour protection cathodique

10...32 V DC

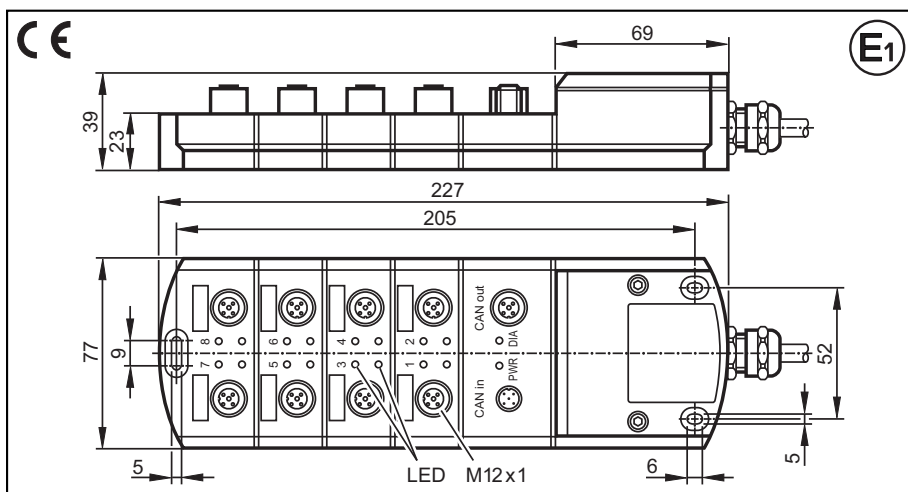

Données techniques

**8 entrées (4 TOR et 4 analogiques/TOR)
8 sorties (4 TOR et 4 TOR/PWM)**

Boîtier	boîtier en zinc moulé sous pression, 8 sorties, avec boîte de raccordement peinture en immersion pour protection cathodique, noire
Dimensions (L x l x H)	227 x 77 x 39 mm (sans presse-étoupe)
Montage	fixation à vis avec 3 vis M5 x L selon DIN 912 ou DIN 7984
Raccordements Tension d'alimentation et bus CAN	borne plate à 7 pôles avec technologie de raccordement CAGE CLAMP® (bornes à ressort) (2 x 2 pôles / 1 x 3 pôles) 0,08...4 mm ² (AWG 28...AWG 12), courant nominal 20 A des potentiels identiques peuvent être shuntés avec des fils de shunt (état départ usine: potentiels GND et UB shuntés) entrée de câble via presse-étoupe M16 8 x connecteur M 12 (prise), 5 pôles 2 x connecteur M 12 (broche/prise), 5 pôles
Entrées / sorties CANin/CANout	
Poids	1,35 kg
Entrées	8
configurables comme	4 TOR, commutation positive (niveau haut) 4 analogiques, 0...10/32 V, 0/4...20 mA radiométriques ou TOR, commutation positive, avec possibilité de diagnostic
Alimentation des capteurs I _{max}	400 mA
Sorties	8
configurables comme	4 TOR, commutation positive (niveau haut), avec possibilité de diagnostic et 4 TOR, commutation positive (niveau haut), avec possibilité de diagnostic ou voie PWM
Courant de commutation par sortie	max. 2 A
Courant total	max. 16 A
Tension d'alimentation U _B	10...32 V DC
Consommation	≤ 60 mA (sans charge externe à 24 V DC)
Température de fonctionnement	-40...85 °C
Température de stockage	-40...85 °C
Protection	IP 67
Interface	interface CAN 2.0 B, ISO 11898
Débit de transmission	20 Kbits/s...1 Mbit/s (valeur par défaut 125 Kbits/s) (réglable à l'aide d'un commutateur rotatif en code hexadécimal dans la boîte de raccordement ou via la liste d'objets CANopen)
Profil de communication	CANopen, CiA DS 301 version 4, CiA DS 401 version 2.1
ID nœud (par défaut)	20 hexa (= déc 32) (réglable à l'aide de deux commutateurs rotatifs en code hexadécimal dans la boîte de raccordement ou via la liste d'objets CANopen)
Affichage	1 LED verte (PWR) 1 LED rouge (diagnostique, DIA) 16 LED jaunes (état des entrées / sorties)



CR2032

Eléments de raccordement et de service

Codage du commutateur rotatif en code hexadécimal

Etats de fonctionnement (LED)

Données techniques

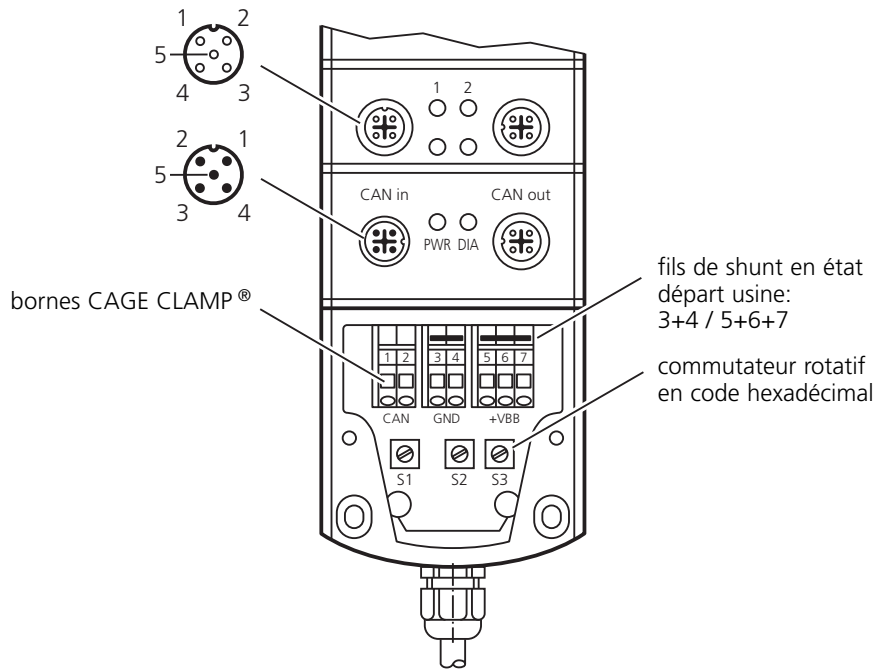

Commutateur	Position	Description
S1 débit de transmission	0	1000 Kbits/s
	1	800 Kbits/s
	2	500 Kbits/s
	3	250 Kbits/s
	4	125 Kbits/s
	5	100 Kbits/s
	6	50 Kbits/s
	7	20 Kbits/s
	8...E	non défini
F	réglage via la liste d'objets (défaut)	
S2 ID nœud _{High}	0...7	quartet haut, par ex. 20 hexa (= déc 32)
	F	réglage via la liste d'objets (défaut)
S3 ID nœud _{Low}	0...E	quartet bas, par ex. 20 hexa (= déc 32)
	F	réglage via la liste d'objets (défaut)



LED	Etat	Description
PWR (verte)	éteinte	pas de tension d'alimentation
	allumée	module en mode stand-by
DIA (rouge)	éteinte	état CANopen: PREOPERATIONAL/PREPARED
	allumée	sorties = inactives
IN (jaune)	éteinte	module actif
	allumée	état CANopen: OPERATIONAL
OUT (jaune)	éteinte	les sorties sont mises à jour
	allumée	communication ok
IN (jaune)	éteinte	communication perturbée
	allumée	<ul style="list-style-type: none"> erreur NodeGuard/Heartbeat (si NodeGuarding/Heartbeat est activé) pas d'objets Synch (si surveillance Synch est activé)
OUT (jaune)	éteinte	entrée TOR commutée
	allumée	erreur diagnostic
OUT (jaune)	éteinte	sortie TOR: sortie commutée (ENCL)
	allumée	sortie analogique: valeur présélectionnée PWM ≠ 0



CR2032

Caractéristiques des entrées/sorties

Entrées

Voie 1, 3, 5, 7 (broche 4)

Voie 1, 3, 5, 7 (broche 2)
configurables comme ...

Sorties

Voie 2, 4, 6, 8 (broche 4)
configurables comme

Voie 2, 4, 6, 8 (broche 2)
configurables comme

Remarque

Test climatique

Résistance mécanique

Immunité aux perturbations conduites

Immunité aux rayonnements parasites

Emission de rayonnements HF

■ Entrées TOR, avec possibilité de diagnostic

niveau d'enclenchement 0,7 U_B
niveau de déclenchement 0,3 U_B
résistance d'entrée 3,21 kΩ
fréquence d'entrée max. 50 Hz

■ Entrées analogiques

tension, courant, radiométriques ou TOR, commutation positive

Entrées tension

tension d'entrée 0...10/32 V
résolution 10 bits
résistance d'entrée 50/30 kΩ
fréquence d'entrée 50 Hz
précision ± 1 % FS

Entrées courant

courant d'entrée 0/4...20 mA
résolution 10 bits
résistance d'entrée 400 Ω
fréquence d'entrée 50 Hz
précision ± 1 % FS

Entrées radiométriques pour des générateurs d'impulsions potentiométriques (par ex. joystick)

fonction $((U_{IN} - \frac{1}{2}U_B) \div \frac{1}{2}U_B) \times 1000 \text{ ‰}$
plage de valeurs 0...1000 ‰

Entrées TOR, avec possibilité de diagnostic

niveau d'enclenchement 0,7 U_B
niveau de déclenchement 0,4 U_B
résistance d'entrée 30 kΩ
fréquence d'entrée max. 50 Hz

■ Sorties à semi-conducteurs, avec possibilité de diagnostic (rupture du câble et court circuit), protégées contre les courts circuits et les surcharges

tension de commutation 10...32 V DC
courant de commutation max. 2 A

■ Sorties PWM

fréquence PWM 20...250 Hz
taux d'impulsion 0...1000 ‰
résolution 1 ‰
courant de commutation max. 2 A (par rapport à la valeur PWM 1000 ‰)

■ Sorties à semi-conducteurs, avec possibilité de diagnostic (rupture du câble et court circuit), protégées contre les courts circuits et les surcharges

tension de commutation 10...32 V DC
courant de commutation max. 2 A

voir aussi schéma de branchement (page suivante)

Normes d'essai et réglementations

chaleur humide selon EN 60068-2-30, test Db
(≤ 95% humidité de l'air relative, sans condensation)
essai de brouillard salin selon EN 60068-2-52, test Kb, niveau de sévérité 3
test de la protection selon EN 60529

vibration selon EN 60068-2-6, test Fc
chocs selon EN 60068-2-27, test Ea
chocs permanents selon EN 60068-2-29, test Eb

selon ISO 7637-2: 2004, impulsions 2a, 3a, 3b, 4, niveau de sévérité 4, état fonctionnel A
selon ISO 7637-2: 2004, impulsion 1, 2b, niveau de sévérité 4, état fonctionnel C
selon ISO 7637-2: 2004, impulsion 5, niveau de sévérité 1, état fonctionnel A

selon UNECE-R10 avec 100 V/m (homologation de type E1) et DIN EN 61000-6-2 (CE)

selon UNECE-R10 (homologation de type E1) et DIN EN 61000-6-3 (CE)

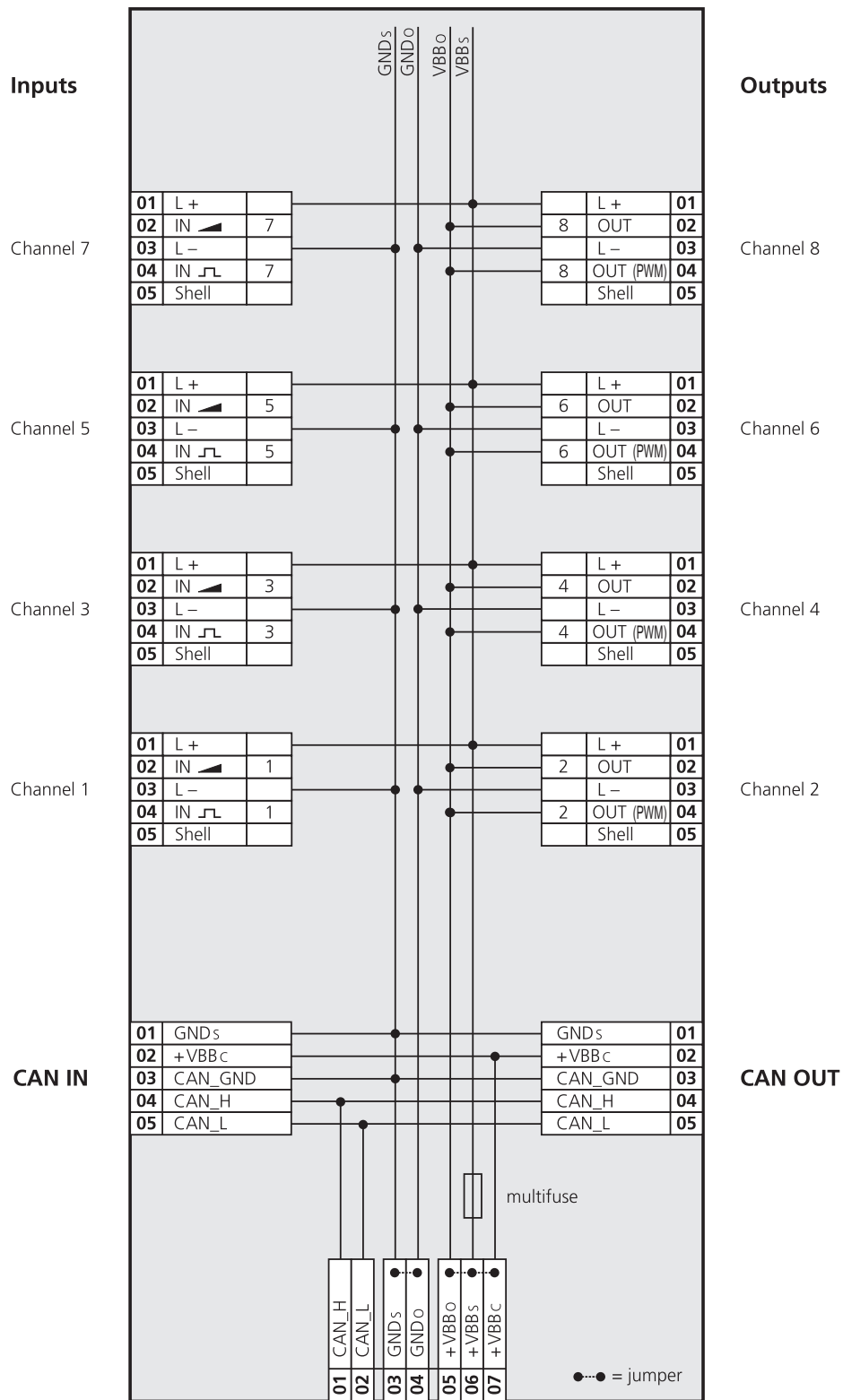

CAN Interface / Supply

Abréviations

















CAN_H = interface CAN (haut)
 CAN_L = interface CAN (bas)
 GND_O = mise à la terre (sortie)
 GND_S = mise à la terre (module)

PWM = sortie pour signaux d'impulsions modulées en largeur
 VBB_C = tension d'alimentation (via connecteur CANin/CANout)
 VBB_O = tension d'alimentation (sortie)
 VBB_S = tension d'alimentation (module)



CR2032

Affectation des LED aux raccordements

CODESYS 2.3 PLC Configuration		Input		Output		CODESYS 2.3 PLC Configuration	
binary inputs	Channel # LED	Pin	Pin	Channel # LED	binary outputs	analogue outputs	
	7			8			
chan 4		2	4		Bit 3	chan 4	
chan 4		4	2		Bit 7		
	5			6			
chan 3		2	4		Bit 2	chan 3	
chan 3		4	2		Bit 6		
	3			4			
chan 2		2	4		Bit 1	chan 2	
chan 2		4	2		Bit 5		
	1			2			
chan 1		2	4		Bit 0	chan 1	
chan 1		4	2		Bit 4		