



**EC2019**

Neigungssensor

$\pm 90^\circ$

15...30 V DC

Ausgang 0...10 V

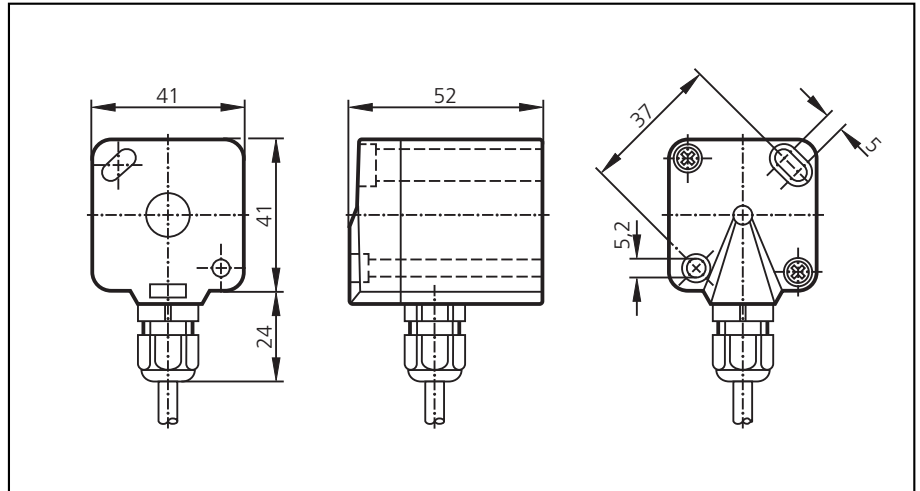

**Verwendung**

Betriebsspannung	[V]
Stromaufnahme max.	[mA]
Ausgang	[V]
Ausgangsfunktion	
Lastwiderstand	[kΩ]
Kurzschlusschutz	
Verpolungssicher, überlastfest	
Winkelbereich ( $\alpha$ )	[°]
Nullpunktfehler	[°]
Wiederholgenauigkeit	[°]
Umgebungstemperatur	[°C]
Schutzart, Schutzklasse	
Gehäusewerkstoff	
Anschluss	
Anschlussbelegung	
Einbaulage	

**Erfassung des absoluten Neigungswinkels**

15...30 DC
< 35
Spannungsausgang 0...10
$U_a = 5 V + \sin(\alpha) \times 5 V$
> 50 gegen Signalmasse am Ausgang
gegen $U_a$ und gegen Masse
•
$\pm 90$
< $\pm 7$
(der Nullpunktfehler kann durch Justage des Geräts um $\pm 4^\circ$ kompensiert werden)
0,1
-30...+85
IP 67
Kunststoff (Nyrol, PPE)
PUR-Kabel, 3,5m/3 x 0,5mm <sup>2</sup>
BK = L+; BN = L-; BU = Ausgang

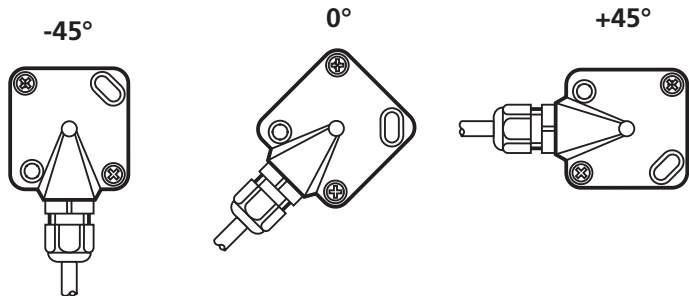



**EC2019**

Neigungssensor

± 90°

15...30 V DC

Ausgang 0...10 V

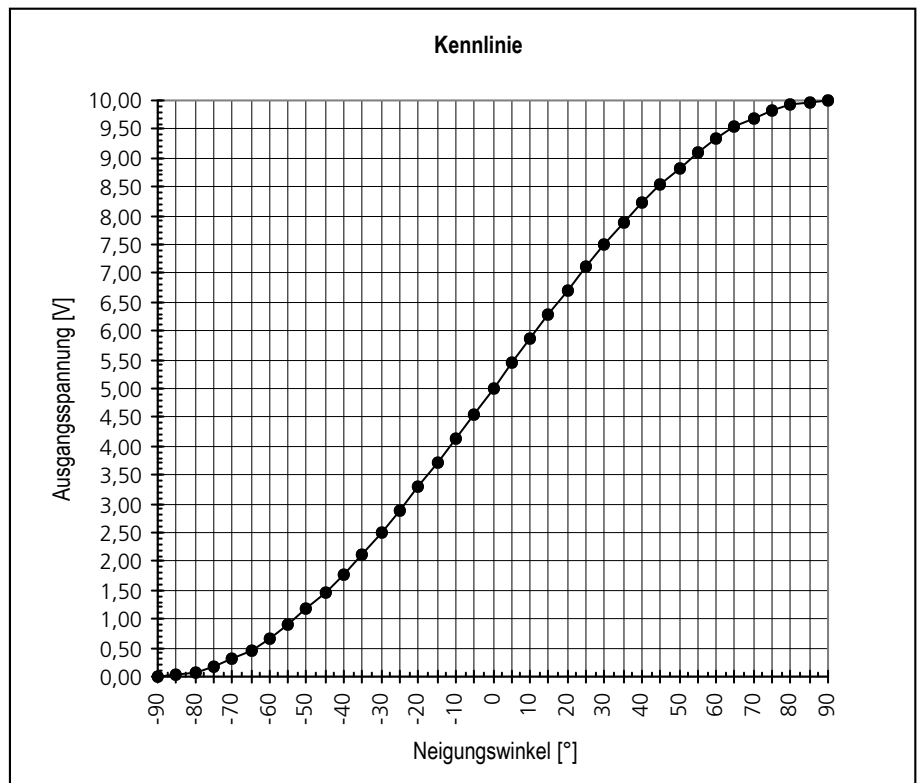

Neigungswinkel [°]	Ausgangsspannung [V]
-90	0,00
-85	0,02
-80	0,08
-75	0,17
-70	0,30
-65	0,47
-60	0,67
-55	0,90
-50	1,17
-45	1,46
-40	1,79
-35	2,13
-30	2,50
-25	2,89
-20	3,29
-15	3,71
-10	4,13
-5	4,56
0	5,00
5	5,44
10	5,87
15	6,29
20	6,71
25	7,11
30	7,50
35	7,87
40	8,21
45	8,54
50	8,83
55	9,10
60	9,33
65	9,53
70	9,70
75	9,83
80	9,92
85	9,98
90	10,00



**EC2019**

Inclination sensor

$\pm 90^\circ$

15...30 V DC

Output 0...10 V

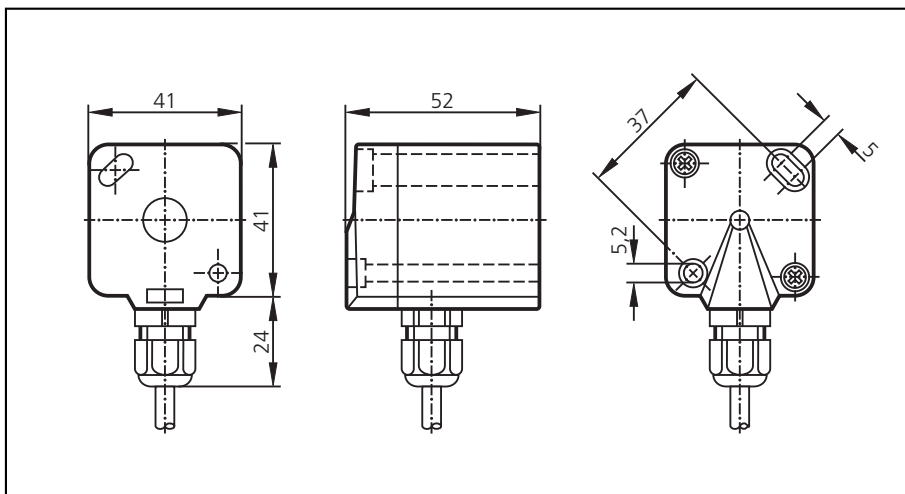

**Application**

**detection of the absolute angle of inclination**

Operating voltage	[V]
Current consumption max.	[mA]
Output	[V]
Output function	
Load impedance	[kΩ]
Short-circuit protection	
Reverse polarity / overload protection	
Angular range ( $\alpha$ )	[°]
Offset zero point error	[°]
Repeatability	[°]
Operating temperature	[°C]
Protection	
Housing material	
Connection	
Wiring	
Mounting position	

15...30 DC
< 35
voltage output 0...10
$U_a = 5 V + \sin(\alpha) \times 5 V$
> 50 to signal ground at the output
to UB and to ground
•
$\pm 90$
< $\pm 7$
(the offset zero point error can be reduced by $\pm 4^\circ$ by adjustment of the unit)
0,1
-30...+85
IP 67
plastic (nyrol, PPE)
PUR cable, 3.5m/3 x 0.5mm <sup>2</sup>
BK = L+; BN = L-; BU = output

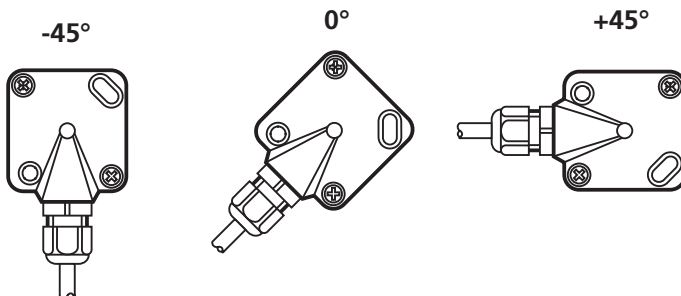



**EC2019**

Inclination sensor

± 90°

15...30 V DC

Output 0...10 V

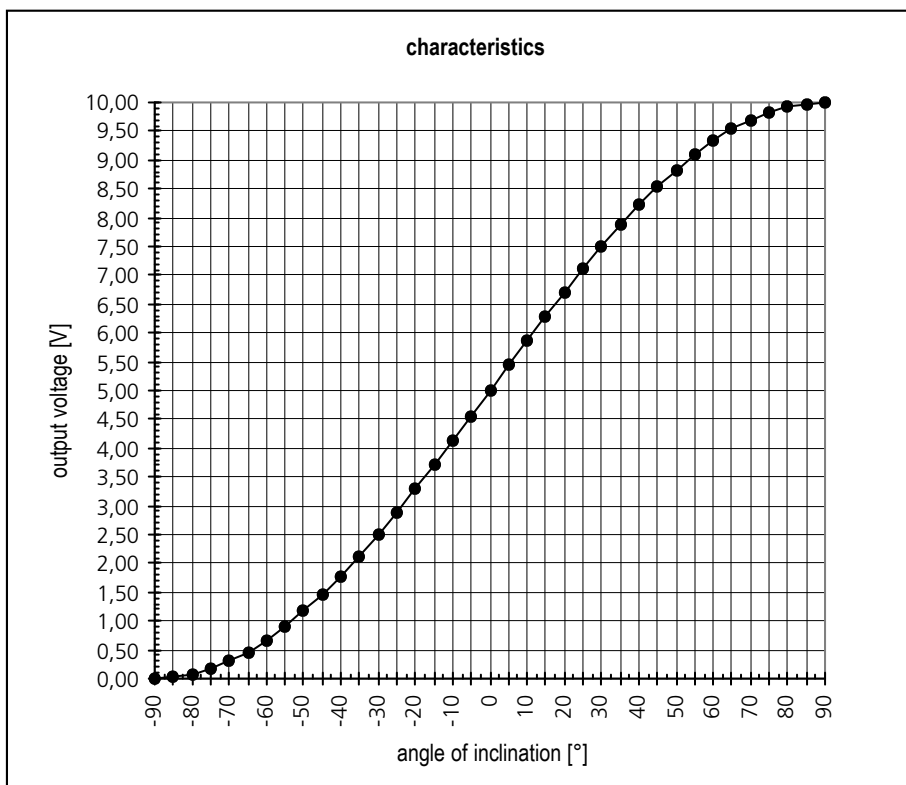

angle of inclination [°]	output voltage [V]
-90	0,00
-85	0,02
-80	0,08
-75	0,17
-70	0,30
-65	0,47
-60	0,67
-55	0,90
-50	1,17
-45	1,46
-40	1,79
-35	2,13
-30	2,50
-25	2,89
-20	3,29
-15	3,71
-10	4,13
-5	4,56
0	5,00
5	5,44
10	5,87
15	6,29
20	6,71
25	7,11
30	7,50
35	7,87
40	8,21
45	8,54
50	8,83
55	9,10
60	9,33
65	9,53
70	9,70
75	9,83
80	9,92
85	9,98
90	10,00



**EC2019**

Capteur d'inclinaison

± 90°

15...30 V DC

Sortie 0...10 V

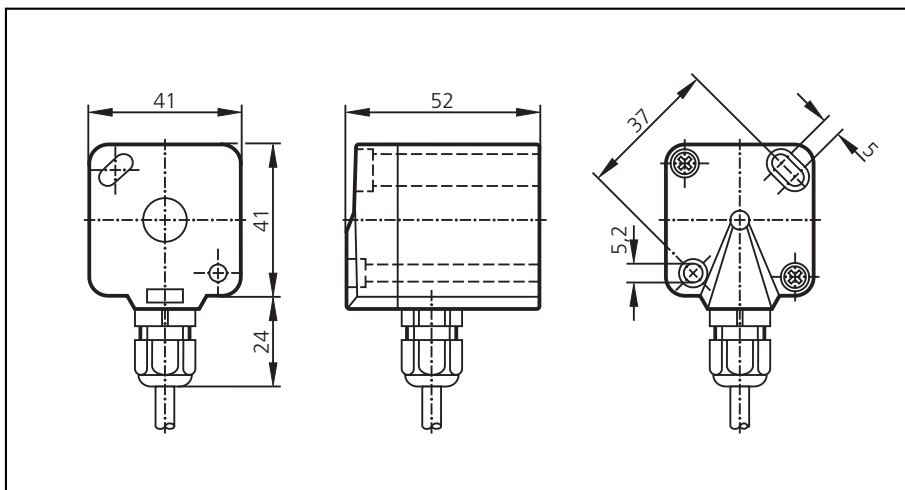

**Application**

Tension d'alimentation	[V]
Consommation maxi	[mA]
Sortie	[V]
Fonction sortie	
Résistance de charge	[kΩ]
Protégé: courts-circuits	
Protégé: inv. de pol. et surcharges	
Plage d'inclinaison (α)	[°]
Déviat ion résiduelle	[°]
Répétabilité	[°]
Température ambiante	[°C]
Protection	
Boîtier	
Raccordement	
Schéma de branchement	
Position de montage	

**détection de l'angle d'inclinaison absolu**

15...30 DC
< 35
sortie tension 0...10
$U_a = 5 V + \sin(\alpha) \times 5 V$
> 50 entre la masse et la sortie
entre UB et la masse
•
± 90
< ± 7 (la déviat ion résiduelle peut être réduite à ± 4° l'ajustage du boîtier)
0,1
-30...+85
IP 67
plastique (nyrol, PPE)
câble PUR, 3,5m/3 x 0,5mm <sup>2</sup>
BK = L+; BN = L-; BU = sortie

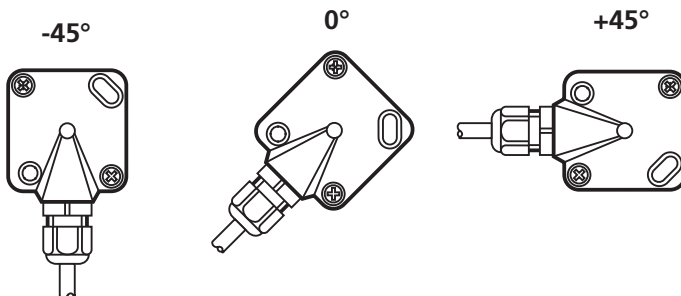



**EC2019**

Capteur d'inclinaison

± 90°

15...30 V DC

Sortie 0...10 V

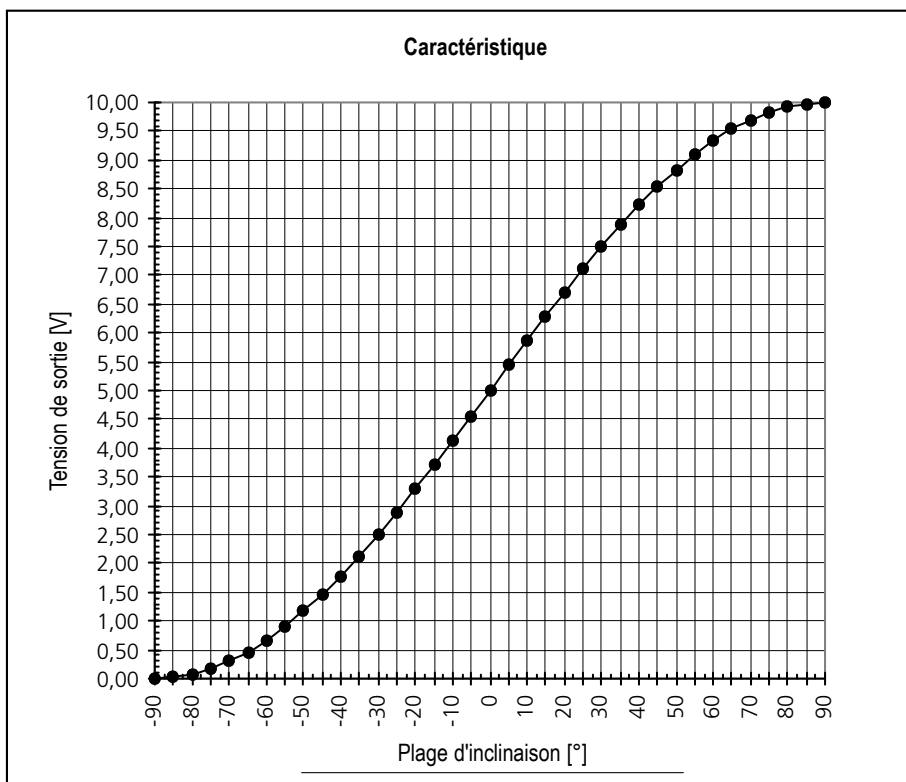

Plage d'inclinaison [°]	Tension de sortie [V]
-90	0,00
-85	0,02
-80	0,08
-75	0,17
-70	0,30
-65	0,47
-60	0,67
-55	0,90
-50	1,17
-45	1,46
-40	1,79
-35	2,13
-30	2,50
-25	2,89
-20	3,29
-15	3,71
-10	4,13
-5	4,56
0	5,00
5	5,44
10	5,87
15	6,29
20	6,71
25	7,11
30	7,50
35	7,87
40	8,21
45	8,54
50	8,83
55	9,10
60	9,33
65	9,53
70	9,70
75	9,83
80	9,92
85	9,98
90	10,00