

Absolute encoders - SSI

Blind hollow shaft $\varnothing 4$ mm

Magnetic singleturn encoders 12 bit

ATD 07S A 4



ATD 07S A 4 with blind hollow shaft

Features

- Encoder singleturn / SSI
- Magnetic sensing method
- Resolution: singleturn 12 bit
- Blind hollow shaft $\varnothing 4$ mm
- Cable output radial
- Clamping ring torsion-proof

Technical data - electrical ratings

Voltage supply	8...26 VDC
Reverse polarity protection	Yes
Consumption w/o load	≤ 40 mA (24 VDC)
Interface	SSI
Function	Singleturn
Steps per revolution	4096 / 12 bit
Sensing method	Magnetic
Code	Gray
Code sequence	CW: ascending values with clockwise sense of rotation; looking at mounting surface
Output stages	SSI data: linedriver RS485

Technical data - mechanical design

Size (flange)	$\varnothing 24$ mm
Shaft type	$\varnothing 4$ mm (blind hollow shaft)
Protection DIN EN 60529	IP 65
Operating speed	≤ 10000 rpm (mechanical) ≤ 10000 rpm (electric)
Starting torque	≤ 0.008 Nm (+20 °C)
Materials	Housing: aluminium Shaft: stainless steel
Operating temperature	-20...+85 °C
Relative humidity	90 % non-condensing
Resistance	DIN EN 60068-2-6 Vibration 10 g, 55-2000 Hz DIN EN 60068-2-27 Shock 100 g, 11 ms
Weight approx.	50 g
Connection	Cable 1 m
Mounting kit	101

Absolute encoders - SSI

Blind hollow shaft $\varnothing 4$ mm
Magnetic singleturn encoders 12 bit

ATD 07S A 4

Part number

ATD 07S A 4 **12** **SS** **GR** **KR1** **S** **4** **IP65** **101**

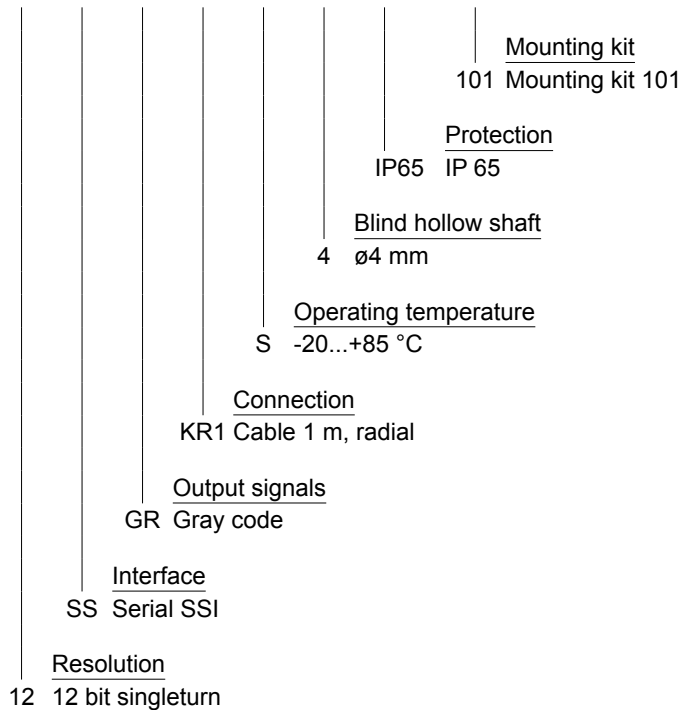

Data transfer

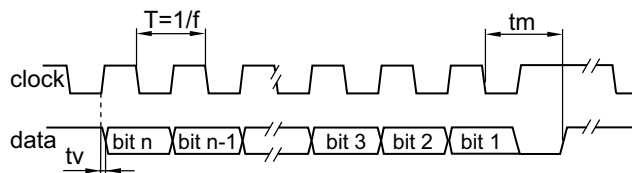

Clock frequency f	80...1000 kHz
Duty cycle of T	40...60 %
Delay time t_v	150 ns
Monoflop time t_m	$20\ \mu s + T/2$
Clock interval t_p	26 μs

Absolute encoders - SSI

Blind hollow shaft $\varnothing 4$ mm

Magnetic singleturn encoders 12 bit

ATD 07S A 4

Trigger level

SSI	Circuit
SSI-Clock	Receiver RS485
SSI-Data	Linedriver RS485

Terminal significance

UB	Encoder supply voltage.
GND	Encoder ground connection relating to UB.
Data+	Positive, serial data output of differential linedriver.
Data-	Negative, serial data output of differential linedriver.
Clock+	Positive SSI clock input. Clock+ together with clock- forms a current loop. A current of approx. 7 mA towards clock+ input means logic 1 in positive logic.
Clock-	Negative SSI clock input. Clock- together with clock+ forms a current loop. A current of approx. 7 mA towards clock- input means logic 0 in positive logic.

Terminal assignment

ATD 07S A 4	
Core colour	Assignment
green	clock-
yellow	clock+
grey	data+
pink	data-
red	UB
blue	GND
transparent	Shield/Housing

Dimensions

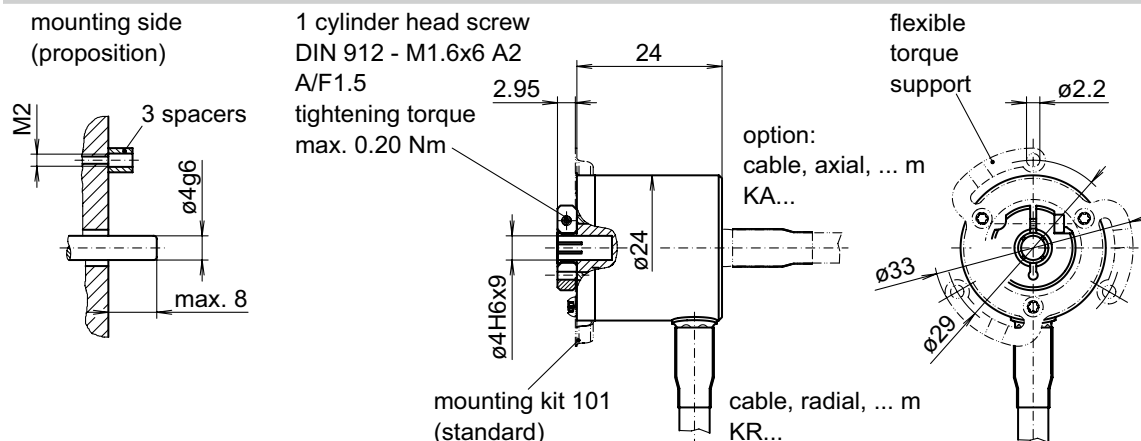

038- 1

Absolute encoders - SSI
Blind hollow shaft $\varnothing 4$ mm
Magnetic singleturn encoders 12 bit

ATD 07S A 4
