

Absolute encoders - analog

Solid shaft $\varnothing 6$ mm with synchro flange

Optical singleturn encoders with analog output

ATD 2A B14 Y 1



ATD 2A B14 Y 1 with synchro flange

Features

- Analog signals
- 14 bit singleturn
- Internal self-diagnostic
- Voltage output or current output
- Factory-set adjustable angle ($0^\circ - 360^\circ$)
- Centering alignment $\varnothing 50$ mm, mounting screw hole circle $\varnothing 68$ mm
- Flange connector radial
- Easy signal processing

Technical data - electrical ratings

Voltage supply	+UB= 12...30 VDC (IS-/IE-/US-/UT-version) -UB= -12...-26 VDC / +UB 12...30 VDC (UE-/UR-version)
Reverse polarity protection	Yes
Consumption w/o load	≤ 50 mA (24 VDC)
Interface	Analog (4...20 mA / 0...20 mA / 0...+5 VDC / 0...+10 VDC / -5...+5 VDC / -10...+10 V)
Load resistor	≥ 1 k Ω (recommended 10 k Ω) / voltage output ≤ 500 Ω (recommended 470 Ω) / current output
Function	Singleturn
Measuring range	90° , 180° , 360°
Steps per revolution	16384 / 14 bit
Sensing method	Optical
Updating values	≤ 130 μ s
Code sequence	CW: ascending values with clockwise sense of rotation; looking at mounting surface
Output stages	Voltage output (short-circuit proof) Current output (short-circuit proof)
Interference immunity	DIN EN 61000-6-2
Emitted interference	DIN EN 61000-6-3

Technical data - mechanical design

Size (flange)	$\varnothing 58$ mm
Shaft type	$\varnothing 6$ mm solid shaft
Flange	Synchro flange
Protection DIN EN 60529	IP 65
Operating speed	≤ 12000 rpm (mechanical) ≤ 6000 rpm (electric)
Starting torque	≤ 0.01 Nm ($+20^\circ\text{C}$)
Admitted shaft load	≤ 20 N axial ≤ 40 N radial
Materials	Housing: aluminium Shaft: stainless steel
Operating temperature	$-20...+85^\circ\text{C}$
Relative humidity	90 % non-condensing
Resistance	DIN EN 60068-2-6 Vibration 10 g, 55-2000 Hz DIN EN 60068-2-27 Shock 30 g, 11 ms
Weight approx.	430 g
Connection	Connector M23 type 2, 12-pin

Absolute encoders - analog

Solid shaft ø6 mm with synchro flange

Optical singleturn encoders with analog output

ATD 2A B14 Y 1

Part number

ATD 2A B14 Y 1 D2SR12 S 6 IP65

Protection

IP65 IP 65

Flange / Solid shaft

6 Synchro flange / ø6 mm

Operating temperature

S -20...+85 °C

Connection

D2SR12 Flange connector type 2, pin contacts, radial, 12-pin

Interface

IS Current output, standard, 4...20 mA, $V_{in} = 12...30$ VDC

IE Current output, extended, 0...20 mA, $V_{in} = 12...30$ VDC

US Voltage output, standard, 0...+10 VDC, $V_{in} = 12...30$ VDC

UE Voltage output, extended, -10...+10 VDC, $V_{in} = -12...-26$ VDC / 12...30 VDC

UT Voltage output, 0...+5 VDC, $V_{in} = 12...30$ VDC

UR Voltage output, reduced, -5...+5 VDC, $V_{in} = -12...-26$ VDC / 12...30 VDC

Resolution

360A 360° mech. angle of rotation, alternating (singleturn)

180A 180° mech. angle of rotation, alternating (singleturn)

180H 180° mech. angle of rotation, High (singleturn)

180L 180° mech. angle of rotation, Low (singleturn)

Other adjustment on request.

Accessories

Connectors and cables

11070180 Connector S2BG12, 10 m cable (ATD analog)

Mounting accessories

11065545 Set of eccentric fixings type A

Absolute encoders - analog

Solid shaft $\varnothing 6$ mm with synchro flange
Optical singleturn encoders with analog output

ATD 2A B14 Y 1

Output signals

Unipolar Output
(IS-/IE-/US-/UT-version)

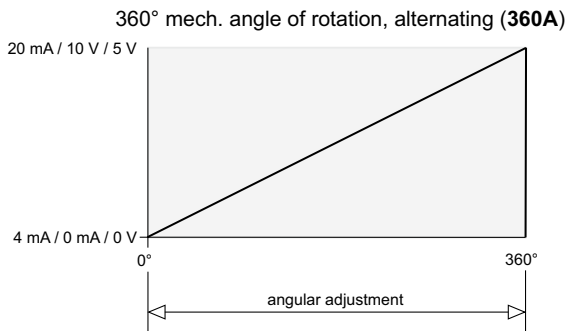

Bipolar Output
(UE-/UR-version)

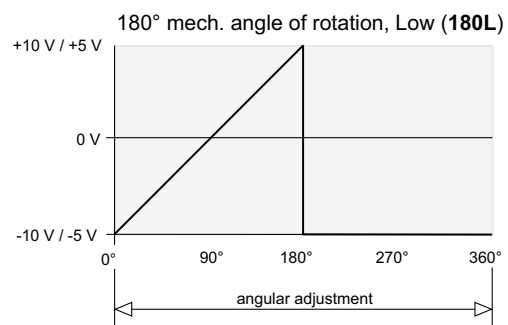
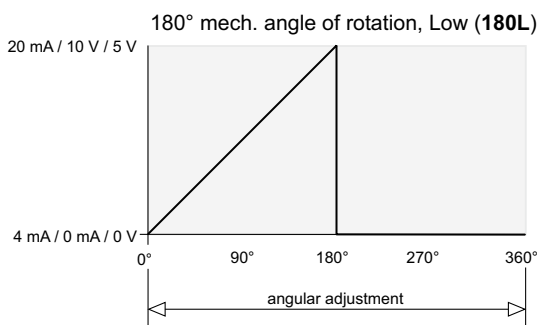
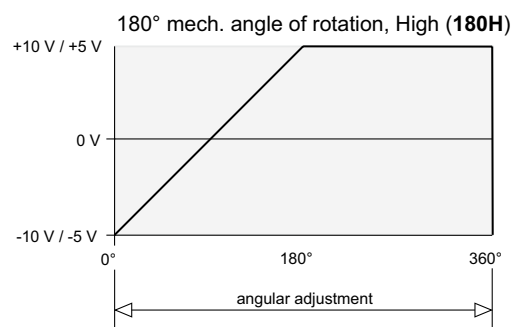
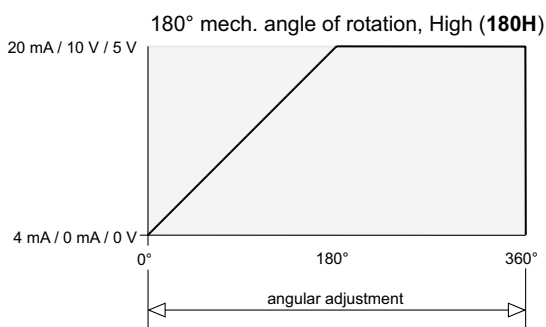
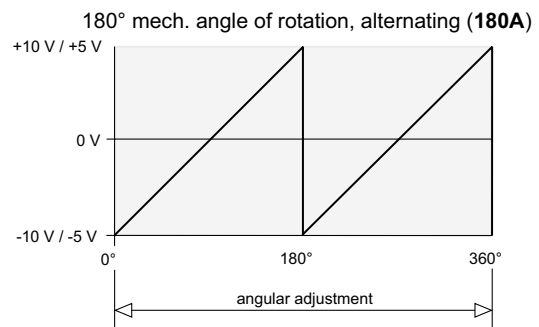
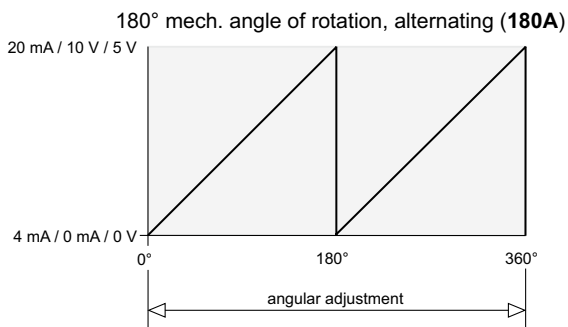
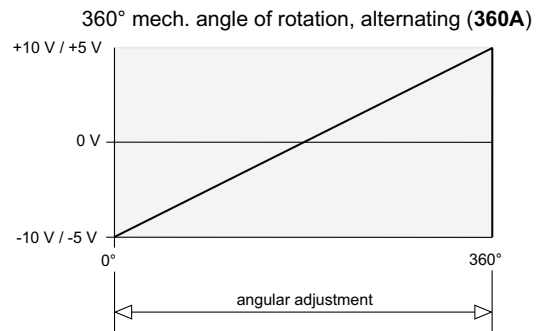

Absolute encoders - analog

Solid shaft $\varnothing 6$ mm with synchro flange

Optical singleturn encoders with analog output

ATD 2A B14 Y 1

Terminal significance

+UB	Encoder supply voltage.
-UB	Negative encoder supply voltage -12 to -26 VDC (only at UE-/UR-version).
GND	Encoder ground connection relating to UB.
U_{OUT}	Voltage output increasing at clockwise rotation when looking at the mounting side.
I_{OUT}	Current output increasing at clockwise rotation when looking at the mounting side.
GND_{OUT}	Reference voltage for analogue output.
Reset	Reset input for setting zero position value at any desired point within the entire resolution. The resetting process is triggered by apply of UB.
V/\bar{R}	V/\bar{R} counting direction input. This input is standard on High. V/\bar{R} means increasing values with clockwise shaft rotation when looking at the mounting side. V/\bar{R} -Low means decreasing values with clockwise shaft rotation when looking at the mounting side.
Error	Diagnostic output (Open Collector with internal 10 k Ω pullup-resistor). The output is low-active, that means if no fault submitted, the output is +UB.

Terminal assignment

ATD 2A B14 Y 1

Connector Assignment

Pin 1	-
Pin 2	-
Pin 3	-
Pin 4	GND_{OUT}
Pin 5	U_{OUT} resp. I_{OUT}
Pin 6	-
Pin 7	reset
Pin 8	V/\bar{R}
Pin 9	error
Pin 10	GND
Pin 11	- / -UB (only at UE-/UR-version)
Pin 12	UB

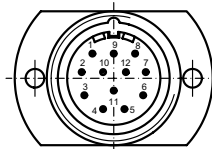

Dimensions

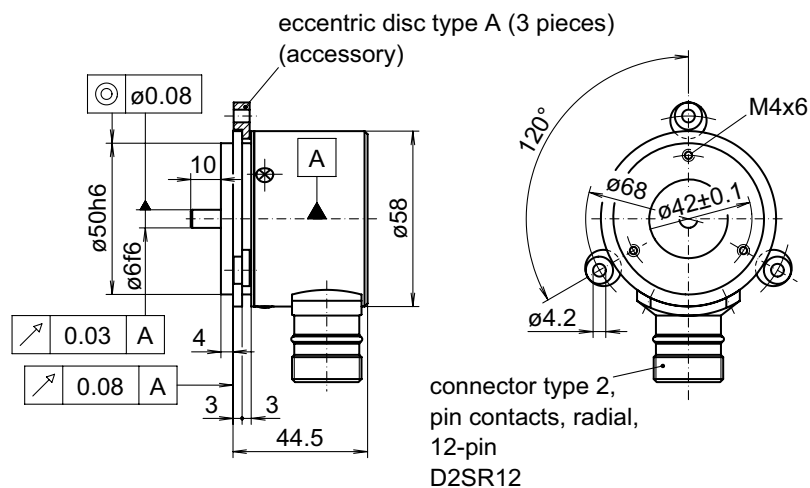

028- 7 Y 1