

Absolute encoders - SSI

Solid shaft $\varnothing 10$ mm with clamping flange

Magnetic multiturn encoders 12 bit ST / 13 bit MT

BMMV 58 SSI - MAGRES hermetic



BMMV 58K SSI with clamping flange

Features

- Encoder multiturn / SSI
- Magnetic sensing, hermetically sealed
- Resolution: singleturn 12 bit, multiturn 13 bit
- High resistance to shock and vibrations
- Reset input
- Protection IP 69K
- Material: stainless steel 1.4305

Technical data - electrical ratings

Voltage supply	5 VDC ± 10 % 10...30 VDC
Consumption typ.	100 mA (5 VDC, w/o load) 50 mA (24 VDC, w/o load)
Initializing time typ.	170 ms after power on
Interface	SSI
Function	Multiturn
Steps per revolution	4096 / 12 bit
Number of revolutions	8192 / 13 bit
Absolute accuracy	$\pm 1^\circ$
Sensing method	Magnetic
Code	Gray or binary
Code sequence	CW: ascending values with clockwise sense of rotation; looking at flange
Inputs	SSI clock Zero setting input
Output stages	SSI data: Linedriver RS422
Interference immunity	DIN EN 61000-6-2
Emitted interference	DIN EN 61000-6-3
Approval	UL approval / E217823

Technical data - mechanical design

Size (flange)	$\varnothing 58$ mm
Shaft type	$\varnothing 10$ mm solid shaft (clamping flange)
Flange	Clamping flange
Protection DIN EN 60529	IP 68, IP 69K
Operating speed	≤ 6000 rpm
Operating torque typ.	0.031 Nm
Admitted shaft load	≤ 120 N axial (combined) ≤ 280 N radial (combined) ≤ 270 N axial (concentrated load)
Materials	Stainless steel 1.4305 (other materials on request)
Operating temperature	$-40 \dots +85^\circ\text{C}$
Resistance	DIN EN 60068-2-6 Vibration 30 g, 10-2000 Hz DIN EN 60068-2-27 Shock 500 g, 6 ms
Weight approx.	690 g
Connection	Connector M12, 8-pin Cable

Absolute encoders - SSI

Solid shaft $\varnothing 10$ mm with clamping flange

Magnetic multiturn encoders 12 bit ST / 13 bit MT

BMMV 58 SSI - MAGRES hermetic

Part number

Multiturn clamping flange

BMMV 58K5 12/13 H0

5 Connection
Cable radial

N Connector
M12, 5-pin,
radial

Solid shaft
H0 $\varnothing 10$ mm, IP 68 and
IP 69K

Resolution
12/13 12/13 bit single-/multiturn

Voltage supply / signals
05C 5 VDC / SSI
24C 10...30 VDC / SSI

Code
N Binary code
G Gray code

Accessories

Connectors and cables

10146775	Female connector M12, 8-pin, straight, without cable
11170528	Female connector M12, 8-pin, straight, shielded, 5 m cable (ESG 34FH0500GVS)
11177375	Female connector M12, 8-pin, straight, shielded, 10 m cable (ESG 34FH1000GVS)

Mounting accessories

10252773	Clamp set $\varnothing 15$ mm
11053277	Bellows coupling aluminium/stainless steel 10 mm

Data transfer

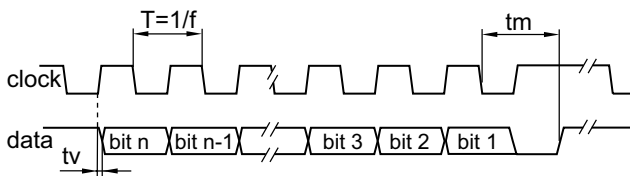

Clock frequency f	100...1000 kHz
Duty cycle of T	40...60 %
Delay time tv	200 ns
Monoflop time tm	$20 \mu\text{s} + T/2$

Trigger level

Control inputs	Input circuit
Input level Low	<0,4 V (>2 ms)
Input level High	+Vs or open

Absolute encoders - SSI

Solid shaft $\varnothing 10$ mm with clamping flange

Magnetic multiturn encoders 12 bit ST / 13 bit MT

BMMV 58 SSI - MAGRES hermetic

Terminal significance

+Vs	Encoder supply voltage.
0 V	Encoder ground connection relating to +Vs.
Data+	Positive, serial data output of differential linedriver.
Data-	Negative, serial data output of differential linedriver.
Clock+	Positive SSI clock input. Clock+ together with Clock- forms a current loop. A current of approx. 7 mA towards Clock+ input means logic 1 in positive logic.
Clock-	Negative SSI clock input. Clock- together with Clock+ forms a current loop. A current of approx. 7 mA towards Clock- input means logic 0 in positive logic.
Zero	Input for setting a zero point anywhere within the encoder resolution. The zero setting operation is triggered by a Low impulse. Connect to +Vs after setting operation for maximum interference immunity. Impulse duration >2 ms.
Rot. direction	Ascending position values when looking at the flange and rotating the shaft clockwise.

Terminal assignment

Cable

for connection reference **-5**

Core colour	Signals	Description
brown	+Vs	Supply voltage
white	0 V	Supply voltage
grey	Data+	Data signal
pink	Data-	Data signal
green	Clock+	Clock signal
yellow	Clock-	Clock signal
blue	Zero	Zero setting input
red	d.u.	do not use
Screen	connected to housing	
Cable data	8 x 0,14 mm ²	

Connector M12 male

for connection reference **-N**

Connector	Signals	Description
Pin 1	0 V	Supply voltage
Pin 2	+Vs	Supply voltage
Pin 3	Clock+	Clock signal
Pin 4	Clock-	Clock signal
Pin 5	Data+	Data signal
Pin 6	Data-	Data signal
Pin 7	Zero	Zero setting input
Pin 8	d.u.	do not use

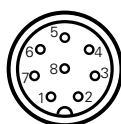

Absolute encoders - SSI

Solid shaft $\varnothing 10$ mm with clamping flange
Magnetic multiturn encoders 12 bit ST / 13 bit MT

BMMV 58 SSI - MAGRES hermetic

Dimensions

BMMV 58 SSI, cable radial

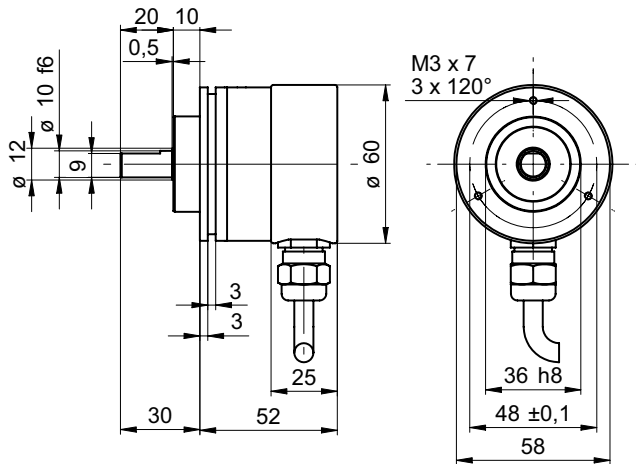

BMMV 58 SSI, connector M12 radial

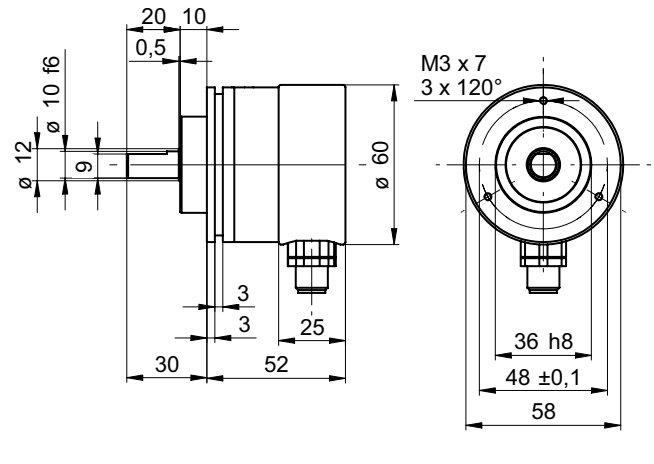

BMMV 58 SSI, cable radial, Ex

