

# Incremental encoders

## Solid shaft with clamping flange

### 100...5000 pulses per revolution

#### ExEIL580-SC



ExEIL580-SC with clamping flange

#### Features

- Size  $\varnothing$ 58 mm
- Precise optical sensing
- Output signal level TTL or HTL
- Clamping flange
- Connection axial, radial or tangential
- Pulses per revolution up to 5000
- High resistance to shock and vibrations
- Option 0122, Explosion protection zone 22

#### Technical data - electrical ratings

Voltage supply	5 VDC $\pm$ 5 % 8...30 VDC 4.75...30 VDC
Reverse polarity protection	Yes
Short-circuit proof	Yes (HTL) Yes (TTL, max. 1 s and 1 signal)
Consumption w/o load	$\leq$ 70 mA
Pulses per revolution	100...5000
Phase shift	90° $\pm$ 10°
Duty cycle	40...60 %
Reference signal	Zero pulse, width 90° $\pm$ 10 %
Sensing method	Optical
Output frequency	$\leq$ 300 kHz (TTL) $\leq$ 160 kHz (HTL)
Output signals	A+, B+, R+, A-, B-, R-
Output stages	TTL/RS422 HTL/push-pull
Interference immunity	DIN EN 61000-6-2
Emitted interference	DIN EN 61000-6-3
Approval	UL 508 / CSA 22.2

#### Technical data - mechanical design

Size (flange)	$\varnothing$ 58 mm
Shaft type	$\varnothing$ 10 x 20 mm, solid shaft with flat
Admitted shaft load	$\leq$ 40 N axial $\leq$ 80 N radial
Flange	Clamping flange
Protection DIN EN 60529	IP 65
Operating speed	$\leq$ 12000 rpm (+20 °C) $\leq$ 11000 rpm (+40 °C) $\leq$ 8000 rpm (+60 °C)
Starting torque	$\leq$ 0.015 Nm (+20 °C)
Materials	Housing: aluminium die-cast Flange: aluminium Solid shaft: stainless steel
Ambient temperature	-20...+60 °C
Relative humidity	90 % non-condensing
Resistance	DIN EN 60068-2-6 Vibration 30 g, 10-2000 Hz DIN EN 60068-2-27 Shock 300 g, 6 ms
Explosion protection	II 3 D Ex tc IIIC T135°C Dc X (dust): see special conditions "X"
Connection	Flange connector M12, 8-pin Flange connector M23, 12-pin Cable
Weight approx.	300 g

# Incremental encoders

## Solid shaft with clamping flange

### 100...5000 pulses per revolution

ExEIL580-SC

#### Part number

ExEIL580-S **C** **10** **.** **5** **.** **.F/** **0122**

Option

0122 ATEX Zone 22

Pulse number - see table

Voltage supply / output stages

- E 5 VDC, TTL/RS422, 6 channel
- H 8...30 VDC, TTL/RS422, 6 channel
- N 8...30 VDC, HTL/push-pull, 6 channel
- Q 4.75...30 VDC, HTL/push-pull, 6 channel

Connection

- R Cable radial, 1 m
- L Cable radial, 2 m
- F Flange connector M23, 12-pin, radial, male, CCW
- B Flange connector M12, 8-pin, radial, male, CCW
- T Cable axial, 1 m
- U Cable axial, 2 m
- D Flange connector M23, 12-pin, axial, male, CCW
- A Flange connector M12, 8-pin, axial, male, CCW
- P Cable tangential, 1 m
- Q Cable tangential, 2 m

Protection

5 IP 65

Specification solid shaft

10 ø10 x 20 mm, with flat

Flange

C Clamping flange, centering collar ø36 mm, M3/M4

#### Pulse number

100	300	720	1250	2500
120	360	800	1440	3000
150	400	900	1500	3600
200	500	1000	1800	4000
250	512	1024	2000	4096
256	600	1200	2048	5000

# Incremental encoders

## Solid shaft with clamping flange

### 100...5000 pulses per revolution

#### ExEIL580-SC

##### Accessories

##### Connectors and cables

10127844	Connection cable 2 m shielded with female connector M12, 8-pin, straight (ESG 34FH0200G)
10129332	Connection cable 5 m shielded with female connector M12, 8-pin, straight (ESG 34FH0500G)
10129333	Connection cable 10 m shielded with female connector M12, 8-pin, straight (ESG 34FH1000G)
11053961	Connection cable 2 m shielded with female connector M12, 8-pin, angled (ESW 33FH0200G)
11053962	Connection cable 5 m shielded with female connector M12, 8-pin, angled (ESW 33FH0500G)
10170054	Connection cable 10 m shielded with female connector M12, 8-pin, angled (ESW 33FH1000G)
10164705	Connector M23, 12-pin
11095302	Connection cable 1 m shielded with female connector M23, 12-pin
11100408	Connection cable 2 m shielded with female connector M23, 12-pin
11100430	Connection cable 5 m shielded with female connector M23, 12-pin
11100431	Connection cable 10 m shielded with female connector M23, 12-pin

##### Mounting accessories

11065915	Coupling CPS25 L=19 d1=04/d2=10
11065918	Coupling CPS25 L=19 d1=07/d2=10
11065920	Coupling CPS25 L=19 d1=08/d2=10
11065921	Coupling CPS25 L=19 d1=09/d2=10
11065922	Coupling CPS25 L=19 d1=10/d2=06
11065923	Coupling CPS25 L=19 d1=10/d2=10
11065924	Coupling CPS25 L=19 d1=10/d2=11
11065925	Coupling CPS25 L=19 d1=10/d2=12
10141132	Spring washer coupling D1=6 / D2=10 (Z 121.C01)
10141133	Spring washer coupling D1=10 / D2=10 (Z 121.C03)
11034138	Spring washer coupling D1=10 / D2=16 (Z 121.C04)
11034140	Spring washer coupling D1=10 / D2=14 (Z 121.C06)
11034141	Spring washer coupling D1=10 / D2=12 (Z 121.C07)
11050507	Bellows coupling aluminium/stainless steel D1=06 / D2=10
11101781	Double loops coupling D1=10 / D2=10

##### Mounting accessories

10125051	Mounting adaptor for encoders with clamping flange (M3) (Z 119.017)
11065545	Set of eccentric fixings type A
11101893	Tether arm

Matching measuring wheels available as accessories, see under "measuring wheels" (MR).

# Incremental encoders

## Solid shaft with clamping flange

### 100...5000 pulses per revolution

ExEIL580-SC

#### Output signals

Clockwise rotating direction when looking at flange.

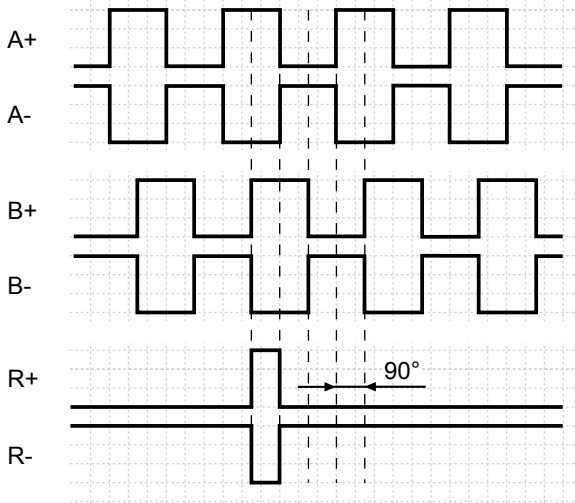

#### Trigger level

Outputs	TTL/RS422
Output level High	$\geq 2.5 \text{ V}$
Output level Low	$\leq 0.5 \text{ V}$
Load	$\leq 20 \text{ mA}$

Outputs	HTL/Push-pull
Output level High	$\geq U_B - 3 \text{ V}$
Output level Low	$\leq 1.5 \text{ V}$
Load	$\leq 20 \text{ mA}$

#### Terminal assignment

##### Flange connector M23, 12-pin / cable

Pin	Core color	Assignment
1	pink	B-
2	–	–
3	blue	R+
4	red	R-
5	green	A+
6	yellow	A-
7	–	–
8	grey	B+
9	–	–
10	white	GND
11	–	–
12	brown	UB

Screen: Connected to housing

Cable data: PVC, [4x2x0.14 mm<sup>2</sup>], bending radius >32.5 mm, outer diameter 6.5 mm

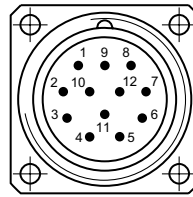

##### Flange connector M12, 8-pin

Pin	Assignment
1	GND
2	UB
3	A+
4	A-
5	B+
6	B-
7	R+
8	R-

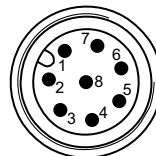

# Incremental encoders

## Solid shaft with clamping flange

### 100...5000 pulses per revolution

## ExEIL580-SC

### Dimensions

#### Flange connector M12, radial

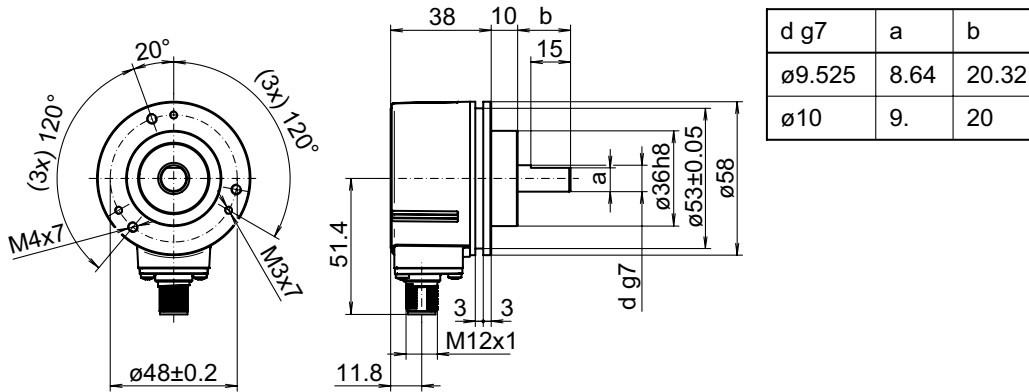

#### Flange connector M23, radial

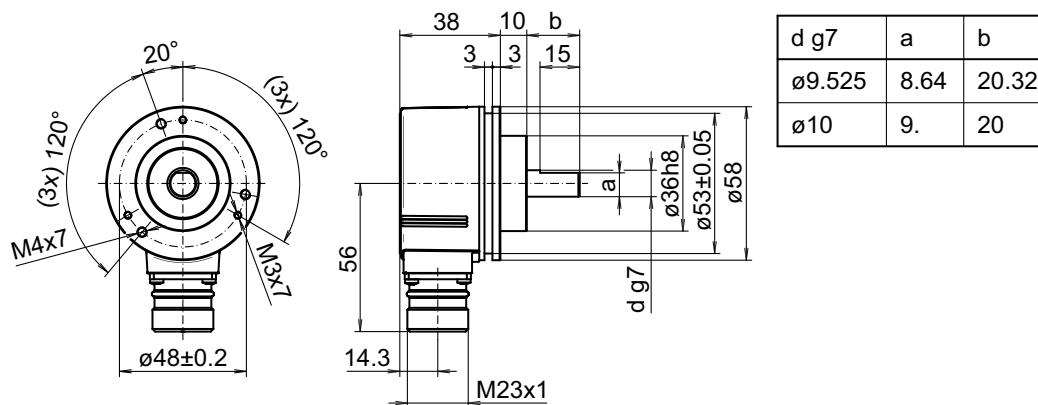

#### Cable, radial

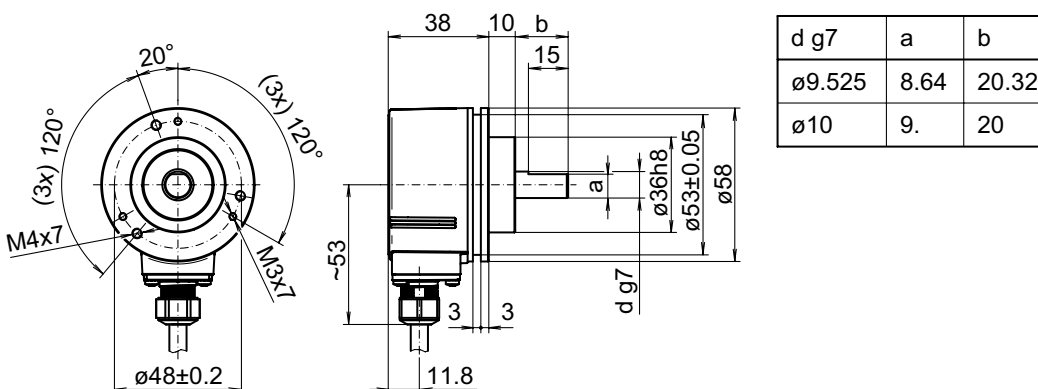

# Incremental encoders

## Solid shaft with clamping flange

### 100...5000 pulses per revolution

ExEIL580-SC

#### Dimensions

##### Flange connector M12, axial

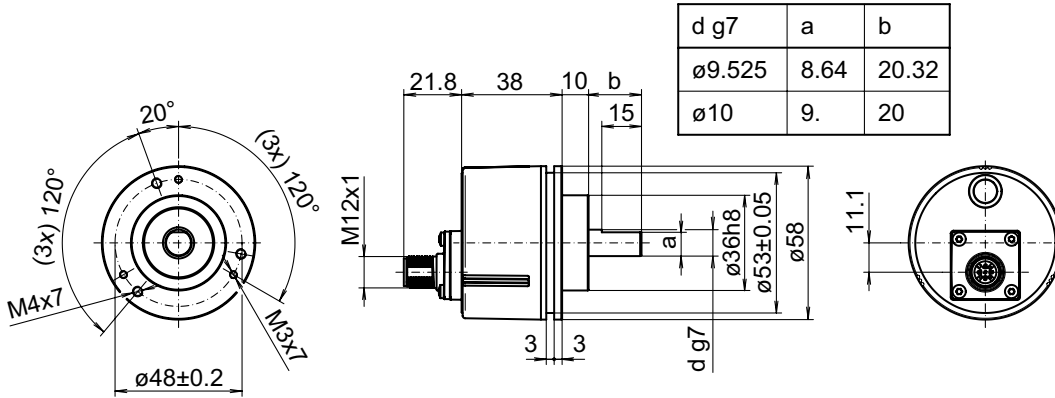

##### Flange connector M23, axial

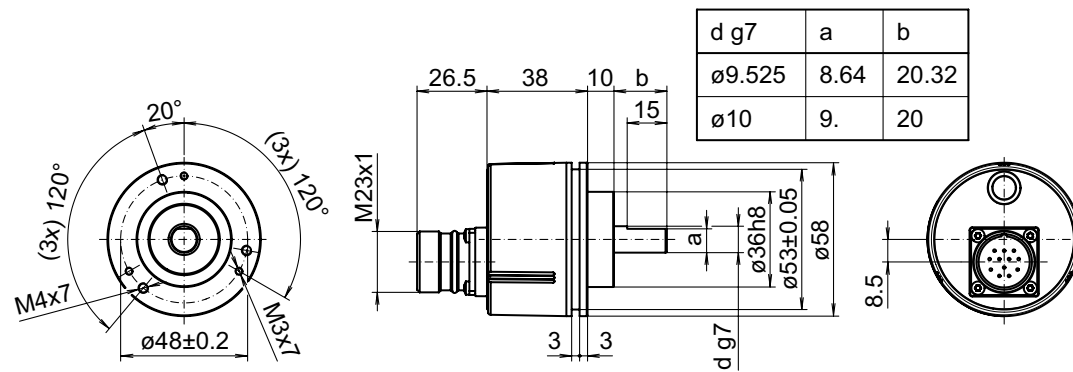

##### Cable, axial

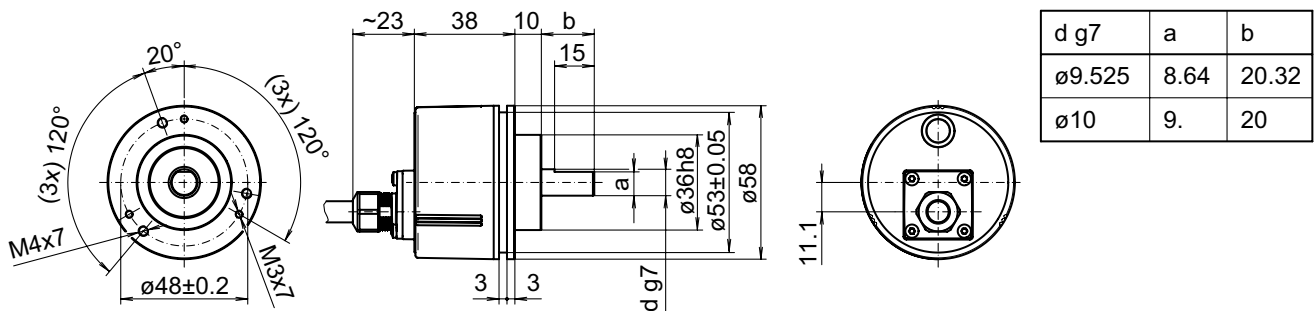

# Incremental encoders

Solid shaft with clamping flange  
100...5000 pulses per revolution

## ExEIL580-SC

### Dimensions

Cable, tangential

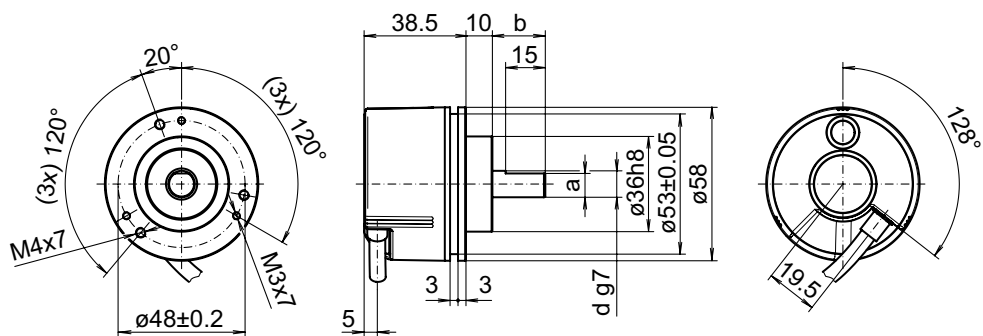

d g7	a	b
$\varnothing 9.525$	8.64	20.32
$\varnothing 10$	9.	20

# Incremental encoders

## Solid shaft with clamping flange

### 100...5000 pulses per revolution

ExEIL580-SC

#### Explosion protection

⊕ II 3 D Ex tc III C T135°C Dc X (dust)

#### General- and Special conditions „X“:

##### Only put the device into operation if ...

- all necessary precautions have been taken by the operator to make sure device and connector are fully protected against mechanical impacts or shocks in compliance with EN 60079-0, section 26.4.2 (Special conditions „X“).
- the connection is mechanically or electrically secured to prevent any interrupt while the contact is live (Special conditions „X“).
- it has been ensured the electrical connection of product variants with cable outlet or cable couplings is outside zone 22 (Special conditions „X“).
- it has been ensured the maximum operating speed in relation to the ambient temperature is within the specifications on the table „Maximum rotation speed below“ (Special conditions „X“).
- the specifications on the product label match the on-site conditions for use in hazardous areas (EX) (device group, category, zone, temperature class resp. maximum surface temperature).
- the specifications on the product label comply with the prevailing grid conditions.
- the device shows no visible trace of damage (resulting from transport or storage), and
- it has been ensured no explosive atmosphere, oils, acids, gases, vapors, radiation etc. are present during installation.

Observe standard EN 60079-14 for installation and commissioning.

**Device operation must observe the installation and operating instructions. The intended use and application of the device comes under the relevant legislation as well as applicable directives and standards.**

#### Maximum rotation speed

	ambient temperature	rotation speed
solid shaft	20 °C	≤ 12000 rpm
	40 °C	≤ 11000 rpm
	60 °C	≤ 8000 rpm
through hollow shaft	20 °C	≤ 6000 rpm
	40 °C	≤ 4500 rpm
	60 °C	≤ 2500 rpm
blind hollow shaft	20 °C	≤ 8000 rpm
	40 °C	≤ 8000 rpm
	60 °C	≤ 5000 rpm