

PG plug system

System PG

PG plug type connection with PVC-cable Protection IP 68

PG-plug connection

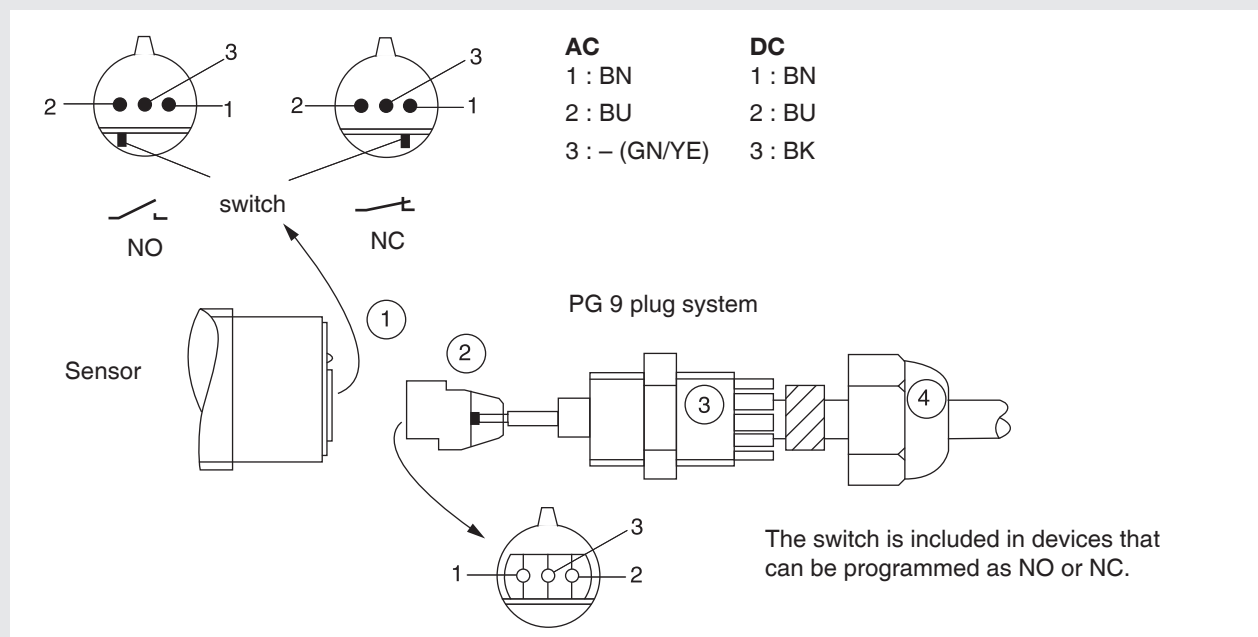

Mounting of PG-Plug system

Connect the cable to the EGE-plug (2) and put it into the plug-housing (1) until it is at the stop. Make sure that the "nose" of the plug fits exactly into the housing. If this is done in the right way, the plug is hidden in the plug-housing.

Screw part (3) into the plug-housing (1) and fix it rightly with a spanner. After about 2 hours righten it again with the spanner.

Now fit the nut (4) by hand and afterwards with a spanner. Do not apply too much force. For a good sealing there should be stet 2 mm between nut (4) and part (3).

TYPE	ID-NO.	DESIGN
PG 2-2	Z00025	PG-plug connection, 2 m PVC-cable 2x0.75 mm ² AC
PG 2-3	Z00026	PG-plug connection, 3 m PVC-cable 2x0.75 mm ² AC
PG 2-5	Z00027	PG-plug connection, 5 m PVC-cable 2x0.75 mm ² AC
PG 2-10	Z00028	PG-plug connection, 10 m PVC-cable 2x0.75 mm ² AC
PG 2-20	Z00029	PG-plug connection, 20 m PVC-cable 2x0.75 mm ² AC
PG 3-2	Z00020	PG-plug connection, 2 m PVC-cable 3x0.5 mm ² DC
PG 3-3	Z00021	PG-plug connection, 3 m PVC-cable 3x0.5 mm ² DC
PG 3-5	Z00022	PG-plug connection, 5 m PVC-cable 3x0.5 mm ² DC
PG 3-10	Z00023	PG-plug connection, 10 m PVC-cable 3x0.5 mm ² DC
PG 3-20	Z00024	PG-plug connection, 20 m PVC-cable 3x0.5 mm ² DC

Note

The power supply must be disconnected before the plug will be installed or removed.

Code: BK = black BN = brown BU = blue GN = green YE = yellow GY = grey PK = pink WH = white