

**AL000030**

**CONNECTION TECHNOLOGY • CABLE SOCKETS /CONNECTORS ONE-SIDED PRE-ASSEMBLED**

ipf cable sockets are used primarily for establishing the electrical connection of sensors. Their features are characterized by rugged design, the highest protection classes (IP67 | IP68 | IP69K) and, if desired, with 360° shielding. With the features: bus-ready, suitable for use with drag chains and robots, resistance to oil and chemicals, resistance to welding sparks, their resistance to cleaning agents or high-pressure and steam-jet cleaning, the expanded temperature range of up to +230°C, the rapid interconnection technology and special data transmission properties, the cable sockets meet all requirements in automation technology.



**MECHANICAL DATA**

Ambient temperature	-10 °C ... 55 °C
Cable length	2 m
Housing material	Plastic
Material of cable sheath	PUR (Polyurethane)
Number of wires	4
Perm. ambient temperature of cable, flexible cable	-10 °C ... 55 °C
Positioning of cable feed, field side	Straight
Positioning of cable feed, housing side	Straight
Suitable for trailing chain	Yes

**ELECTRICAL DATA**

Line diameter	3 mm
Number of pins	4
Number of pins, housing side	4
Type of electrical connection, field side	Blade terminal
Type of electrical connection, housing side	Free conductor end
Type of plug-in contact, field side	Female (socket) / male (plug)

**OTHER DATA**

Flame resistant	No
Welding area	Yes

## DIMENSIONAL DRAWING

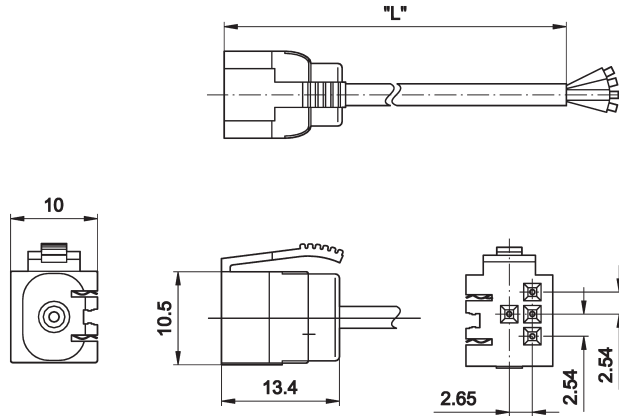

## INSTALLATION



Mounting / Installation may only be carried out by a qualified electrician!

## DISPOSAL



## SAFETY WARNINGS

Before initial operation, please make sure to follow all safety instructions that may be provided in the product information!