

**Features**

- 1-channel signal conditioner
- 24 V DC supply (Power Rail)
- Level sensing input
- Adjustable range 5 kΩ ... 150 kΩ
- Relay contact output
- Minimum/maximum control

**Function**

This signal conditioner provides the AC measuring voltage for the level-sensing electrodes.

Once the measured medium reaches the electrodes, the unit reacts by energizing a form C changeover relay contact.

The module is voltage and temperature stabilized and guarantees defined switching characteristics. An electronic holding circuit is used that allows minimum/maximum control. Since the conductance of the media may vary, the relay response sensitivity is adjustable.

The normal output state can be reversed through the mode of operation switch S1.

**Assembly**

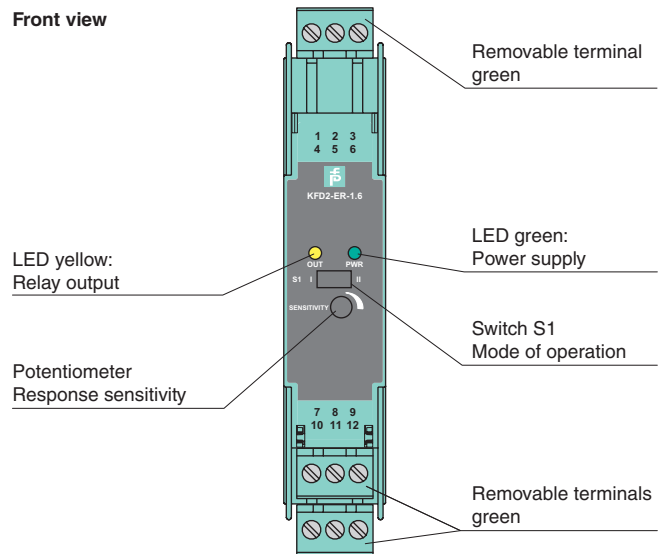

**Connection**

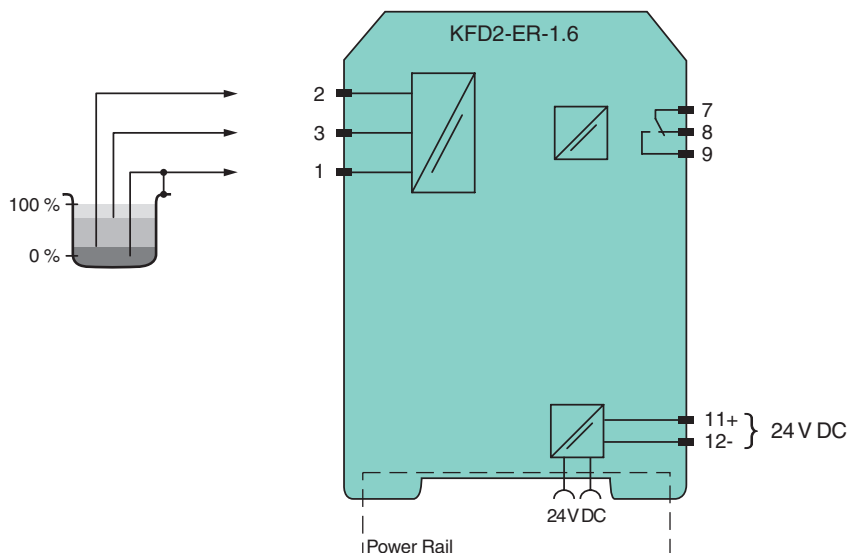

Release date 2018-05-08 08:06 Date of issue 2018-05-08 09:6864\_eng.xml

Refer to "General Notes Relating to Pepperl+Fuchs Product Information".

<b>General specifications</b>	
Signal type	Digital Input
<b>Supply</b>	
Connection	Power Rail or terminals 11+, 12-
Rated voltage $U_r$	20 ... 30 V DC
<b>Input</b>	
Connection side	field side
Connection	terminals 1 (mass), 2 (min), 3 (max)
Open circuit voltage/short-circuit current	approx. 10 V AC (approx. 1 Hz) / approx. 5 mA
Control input	min./max. control system: terminals 1, 2, 3 on/off control system: terminals 1, 3
Response sensitivity	5 ... 150 k $\Omega$ , adjustable via potentiometer (20 turns)
<b>Output</b>	
Connection side	control side
Connection	terminals 7, 8, 9
Output	1 changeover contact
Contact loading	253 V AC/2 A/cos $\phi$ > 0.7; 40 V DC/2 A resistive load
Energized/De-energized delay	approx. 1 s / approx. 1 s
<b>Galvanic isolation</b>	
Input/Output	reinforced insulation according to IEC/EN 61010-1, rated insulation voltage 300 V <sub>eff</sub>
Input/power supply	reinforced insulation according to IEC/EN 61010-1, rated insulation voltage 300 V <sub>eff</sub>
Output/power supply	reinforced insulation according to IEC/EN 61010-1, rated insulation voltage 300 V <sub>eff</sub>
<b>Indicators/settings</b>	
Display elements	LEDs
Control elements	DIP-switch potentiometer
Configuration	via DIP switches via potentiometer
Labeling	space for labeling at the front
<b>Directive conformity</b>	
Electromagnetic compatibility	
Directive 2014/30/EU	EN 61326-1:2013 (industrial locations)
Low voltage	
Directive 2014/35/EU	EN 61010-1:2010
<b>Conformity</b>	
Electromagnetic compatibility	NE 21:2006
Degree of protection	IEC 60529:2001
<b>Ambient conditions</b>	
Ambient temperature	-20 ... 60 °C (-4 ... 140 °F)
<b>Mechanical specifications</b>	
Degree of protection	IP20
Connection	screw terminals , max. 2.5 mm <sup>2</sup>
Mass	approx. 110 g
Dimensions	20 x 107 x 115 mm (0.8 x 4.2 x 4.5 inch) , housing type B1
Mounting	on 35 mm DIN mounting rail acc. to EN 60715:2001
<b>Indication and operation</b>	
Control elements	switch S1 Position I open circuit current: In the open circuit current principle, the relay becomes active when the limit is reached. Position II closed circuit current: In closed circuit current principle, the relay is activated when power is applied. The relay is deactivated when the limit is reached.
<b>General information</b>	
Supplementary information	Observe the certificates, declarations of conformity, instruction manuals, and manuals where applicable. For information see <a href="http://www.pepperl-fuchs.com">www.pepperl-fuchs.com</a> .

Release date 2018-05-08 08:06 Date of issue 2018-05-08 09:58:04\_eng.xml

## Accessories

### Power feed module KFD2-EB2

The power feed module is used to supply the devices with 24 V DC via the Power Rail. The fuse-protected power feed module can supply up to 150 individual devices depending on the power consumption of the devices. Collective error messages received from the Power Rail activate a galvanically-isolated mechanical contact.

### Power Rail UPR-03

The Power Rail UPR-03 is a complete unit consisting of the electrical insert and an aluminium profile rail 35 mm x 15 mm. To make electrical contact, the devices are simply engaged.

### Profile Rail K-DUCT with Power Rail

The profile rail K-DUCT is an aluminum profile rail with Power Rail insert and two integral cable ducts for system and field cables. Due to this assembly no additional cable guides are necessary.



*Power Rail and Profile Rail must not be fed via the device terminals of the individual devices!*