

**Features**

- 1-channel isolated barrier
- 24 V DC supply (Power Rail)
- Dry contact or NAMUR inputs
- Active transistor output
- Active fault output
- Line fault detection (LFD)
- Reversible mode of operation
- Up to SIL 2 acc. to IEC 61508

**Function**

This isolated barrier is used for intrinsic safety applications. It transfers digital signals (NAMUR sensors/mechanical contacts) from a hazardous area to a safe area.

The proximity sensor or switch controls an active transistor output per channel for the safe area load. The normal output state is reversed using switch S1. Switch S2 allows output II to be switched between a signal output and an error message output. Switch S3 enables or disables line fault detection of the field circuit.

During an error condition, the transistors revert to their de-energized state and LEDs indicate the fault according to NAMUR NE44.

A unique collective error messaging feature is available when used with the Power Rail system.

**Assembly**

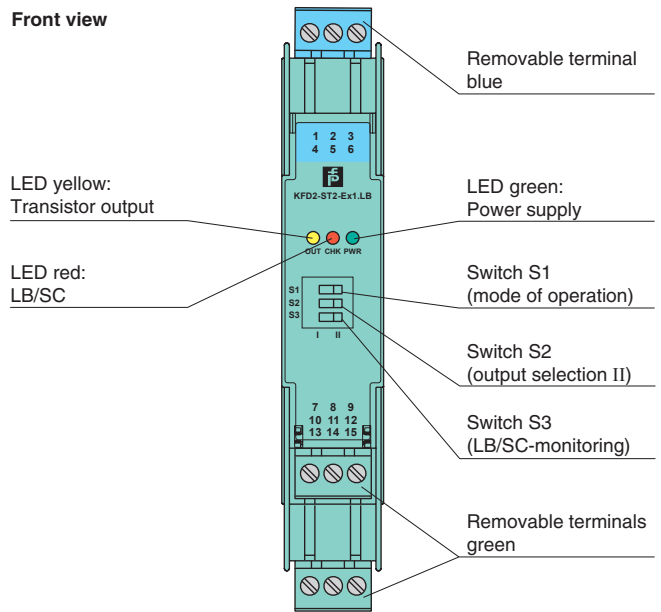

**Connection**

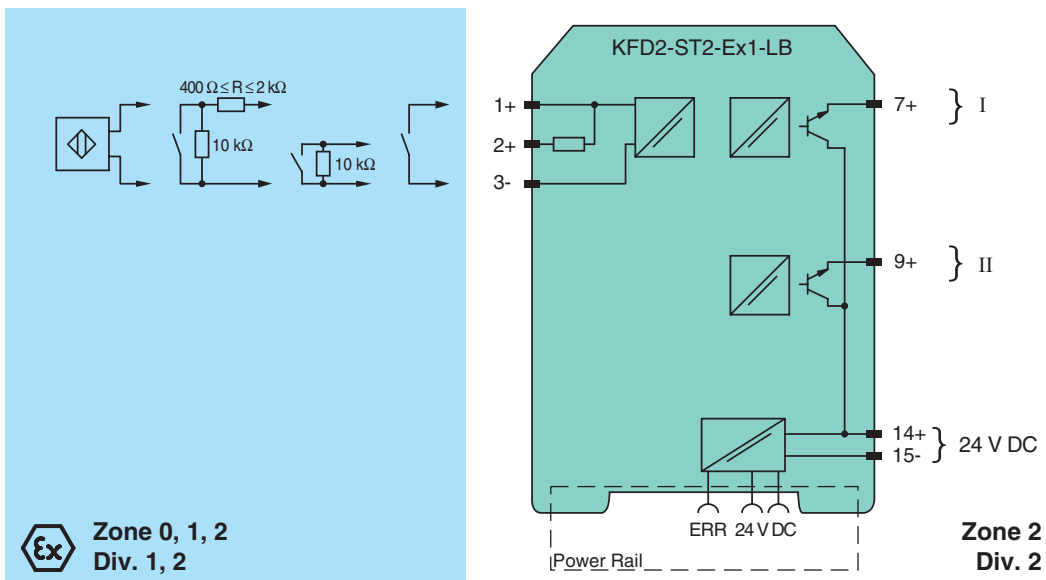

Release date 2019-01-25 09:38 Date of issue 2019-01-25 180997\_eng.xml

Refer to "General Notes Relating to Pepperl+Fuchs Product Information".

<b>General specifications</b>		
Signal type		Digital Input
<b>Functional safety related parameters</b>		
Safety Integrity Level (SIL)		SIL 2
<b>Supply</b>		
Connection		Power Rail or terminals 14+, 15-
Rated voltage	$U_r$	20 ... 30 V DC
Ripple		≤ 10 %
Rated current	$I_r$	≤ 50 mA
<b>Input</b>		
Connection side		field side
Connection		terminals 1+, 2+, 3-
Rated values		acc. to EN 60947-5-6 (NAMUR), see system description for electrical data
Open circuit voltage/short-circuit current		approx. 8 V DC / approx. 8 mA
Switching point/switching hysteresis		1.2 ... 2.1 mA / approx. 0.2 mA
Line fault detection		breakage $I \leq 0.1$ mA , short-circuit $I > 6$ mA
<b>Output</b>		
Connection side		control side
Connection		output I: terminals 7+ ; output II: terminals 9+
Signal level		1-signal: (L+) - 3.5 V (100 mA, short-circuit protected) 0-signal: switched off (off-state current ≤ 10 μA)
Output I		signal , electronic output, active
Output II		signal or error message , electronic output, active
Collective error message		Power Rail
<b>Transfer characteristics</b>		
Switching frequency		≤ 5 kHz
<b>Galvanic isolation</b>		
Input/Output		reinforced insulation acc. to IEC 62103, rated insulation voltage 300 V <sub>rms</sub>
Input/power supply		reinforced insulation acc. to IEC 62103, rated insulation voltage 300 V <sub>rms</sub>
Output/power supply		not available , common pole terminal 14+
Output/Output		not available , common pole terminal 14+
<b>Indicators/settings</b>		
Display elements		LEDs
Control elements		DIP-switch
Configuration		via DIP switches
Labeling		space for labeling at the front
<b>Directive conformity</b>		
Electromagnetic compatibility		
Directive 2014/30/EU		EN 61326-1:2013 (industrial locations)
<b>Conformity</b>		
Galvanic isolation		IEC 62103:2003
Electromagnetic compatibility		NE 21:2004
Degree of protection		IEC 60529:2001
Input		EN 60947-5-6:2000
<b>Ambient conditions</b>		
Ambient temperature		-20 ... 60 °C (-4 ... 140 °F)
<b>Mechanical specifications</b>		
Degree of protection		IP20
Connection		screw terminals
Mass		approx. 150 g
Dimensions		20 x 119 x 115 mm (0.8 x 4.7 x 4.5 inch) , housing type B2
Mounting		on 35 mm DIN mounting rail acc. to EN 60715:2001
<b>Data for application in connection with hazardous areas</b>		
EU-Type Examination Certificate		PTB 00 ATEX 2035
Marking		⊕ II (1) G [Ex ia] IIC ⊕ II (1) D [Ex ia] IIIC
Input		Ex ia IIC, Ex ia IIIC
Voltage	$U_o$	10.5 V
Current	$I_o$	13 mA
Power	$P_o$	34 mW (linear characteristic)
<b>Supply</b>		
Maximum safe voltage	$U_m$	40 V DC (Attention! The rated voltage can be lower.)
Type of protection [Ex ia and Ex ib]		
Output		

Release date 2019-01-25 09:38 Date of issue 2019-01-25 180997\_eng.xml

Refer to "General Notes Relating to Pepperl+Fuchs Product Information".

Maximum safe voltage	U <sub>m</sub>	40 V DC (Attention! The rated voltage can be lower.)
Certificate		TÜV 99 ATEX 1499 X
Marking		 II 3G Ex nA II T4
Galvanic isolation		
Input/Output		safe electrical isolation acc. to IEC/EN 60079-11, voltage peak value 375 V
Input/power supply		safe electrical isolation acc. to IEC/EN 60079-11, voltage peak value 375 V
Directive conformity		
Directive 2014/34/EU		EN 60079-0:2012+A11:2013 , EN 60079-11:2012 , EN 60079-15:2010 , EN 50303:2000
<b>International approvals</b>		
FM approval		
Control drawing		116-0035
CSA approval		
Control drawing		116-0047
IECEX approval		
IECEX certificate		IECEX PTB 05.0011
IECEX marking		[Ex ia] IIC , [Ex ia] I , [Ex ia] IIIC
<b>General information</b>		
Supplementary information		Observe the certificates, declarations of conformity, instruction manuals, and manuals where applicable. For information see <a href="http://www.pepperl-fuchs.com">www.pepperl-fuchs.com</a> .
<b>Accessories</b>		
Optional accessories		<ul style="list-style-type: none"> <li>- power feed module KFD2-EB2(.R4A.B)(.SP)</li> <li>- universal power rail UPR-03(-M)(-S)</li> <li>- profile rail K-DUCT-BU(-UPR-03)</li> </ul>

**Configuration**

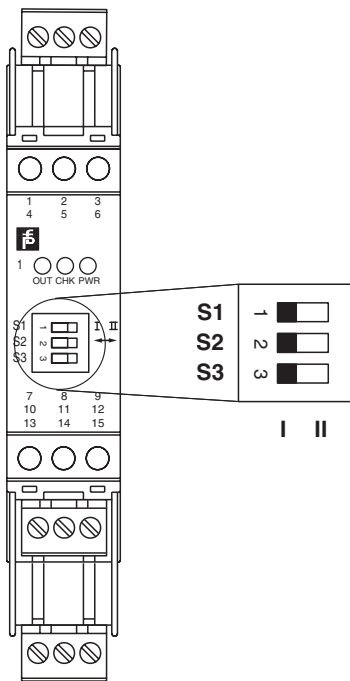

**Switch position**

S	Function		Position
1	Mode of operation Output I active	with high input current	I
		with low input current	II
2	Assignment Output II	switching state like output I	I
		fault signal output (passive if fault)	II
3	Line fault detection	ON	I
		OFF	II

**Operating status**

Control circuit	Input signal
Initiator high impedance/ contact opened	low input current
Initiator low impedance/ contact closed	high input current
Lead breakage, lead short-circuit	Line fault

Factory settings: switch 1, 2 and 3 in position I