

**Features**

- 2-channel isolated barrier
- 24 V DC supply (bus powered)
- 2-wire SMART transmitter
- Output for 4 mA ... 20 mA or 1 V ... 5 V
- Low power dissipation
- Up to SIL 2 acc. to IEC 61508

**Function**

This isolated barrier is used for intrinsic safety applications. It provides 2-wire SMART transmitters with power in the hazardous area, and repeats the current to drive a safe area load.

Bi-directional communication is supported for SMART transmitters that use current modulation to transmit data and voltage modulation to receive data.

The outputs are isolated from the inputs and are referenced to the power supply common.

This module mounts on a HiD Termination Board.

**Application**

The device supports the following SMART protocols:

- HART
- BRAIN
- Bailey (only STT02 communication, e. g. BCN series)
- Foxboro

**Assembly**

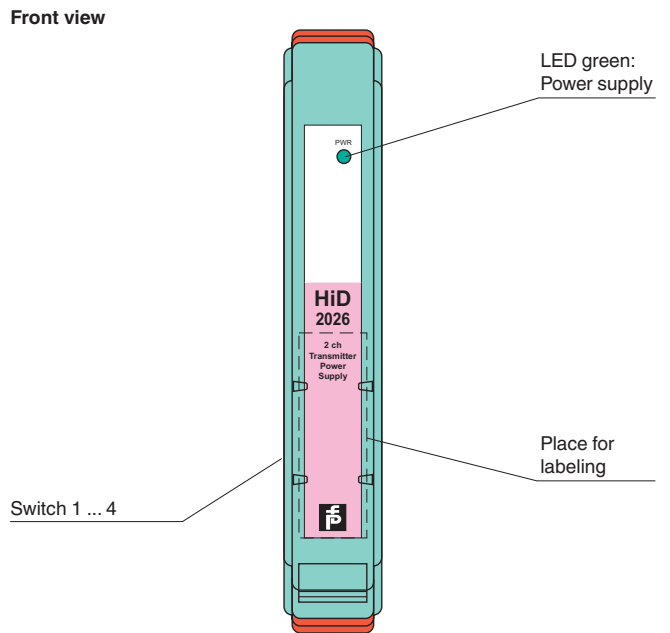

**Connection**

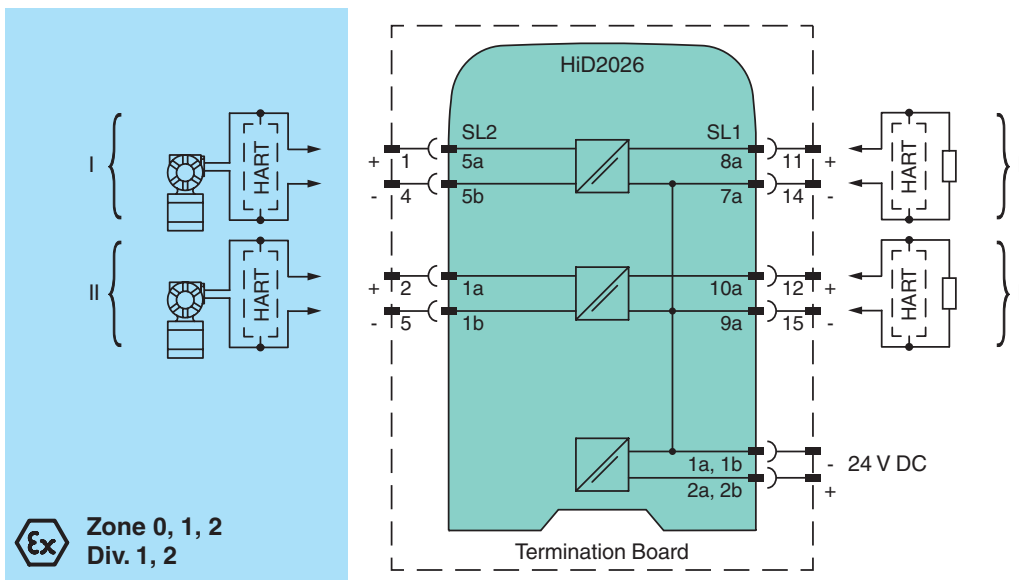

Release date 2017-08-09 14:51 Date of issue 2017-08-10 196449\_eng.xml

Refer to "General Notes Relating to Pepperl+Fuchs Product Information".

Pepperl+Fuchs Group  
www.pepperl-fuchs.com

USA: +1 330 486 0002  
pa-info@us.pepperl-fuchs.com

Germany: +49 621 776 2222  
pa-info@de.pepperl-fuchs.com

Singapore: +65 6779 9091  
pa-info@sg.pepperl-fuchs.com

<b>General specifications</b>		
Signal type		Analog input
<b>Functional safety related parameters</b>		
Safety Integrity Level (SIL)		SIL 2
<b>Supply</b>		
Connection		SL1: 1a(-), 1b(-); 2a(+), 2b(+)
Rated voltage	$U_r$	20.4 ... 30 V DC bus powered via Termination Board
Rated current	$I_r$	95 mA at 24 V, 20 mA output
Power dissipation		0.8 W at 24 V (per channel)
<b>Input</b>		
Connection side		field side
Connection		SL2: 5a(+), 5b(-); 1a(+), 1b(-)
Input current		4 ... 20 mA , current limit 26 mA typ.
Ripple		10 mV <sub>eff</sub>
Voltage		min. 15.5 V at 20 mA
<b>Output</b>		
Connection side		control side
Connection		SL1: 8a(+), 7a(-); 10a(+), 9a(-)
Load		0 ... 650 Ω
Output signal		4 ... 20 mA or 1 ... 5 V (on 250 Ω, 0.1 % internal shunt)
Ripple		10 mV <sub>eff</sub> on a load of 250 Ω
Response time		40 ms , 10 ... 90 % step change
<b>Transfer characteristics</b>		
Calibrated accuracy		< ± 0.1 % of full-scale value (current output)
Influence of temperature		< 2 μA/K (0 ... 60 °C (32 ... 140 °F)); < 4 μA/K (-20 ... 0 °C (-4 ... 32 °F)) 0.01 %/ K
Frequency range		communication channel: 0.5 ... 40 kHz within 3 db, (-6 db at 100 kHz), Tx to output and output to Tx, suitable for use with SMART transmitters using HART or similar protocol
Influence of load		< ± 0.1 % of full-scale value from 0 ... 650 Ω
Linearity		< ± 0.1 % of full-scale value
<b>Galvanic isolation</b>		
Input/Output		safe electrical isolation acc. to EN 60079-11: 2007, voltage peak value 375 V
Input/power supply		safe electrical isolation acc. to EN 60079-11: 2007, voltage peak value 375 V
Output/power supply		none
Input/input		safe electrical isolation acc. to EN 60079-11: 2007, voltage peak value 60 V
<b>Indicators/settings</b>		
Display elements		LED
Control elements		DIP-switch
Configuration		via DIP switches
Labeling		space for labeling at the front
<b>Directive conformity</b>		
Electromagnetic compatibility		
Directive 2014/30/EU		EN 61326-1:2013 (industrial locations)
<b>Conformity</b>		
Electromagnetic compatibility		NE 21:2006 For further information see system description.
Degree of protection		IEC 60529:2001
<b>Ambient conditions</b>		
Ambient temperature		-20 ... 60 °C (-4 ... 140 °F)
Relative humidity		5 ... 90 % , non-condensing up to 35 °C (95 °F)
<b>Mechanical specifications</b>		
Degree of protection		IP20
Mass		approx. 140 g
Dimensions		18 x 106 x 128 mm (0.7 x 4.2 x 5 inch)
Mounting		on Termination Board
Coding		pin 1 and 3 trimmed For further information see system description.
<b>Data for application in connection with hazardous areas</b>		
EU-Type Examination Certificate		CESI 10 ATEX 025
Marking		⊕ II (1)GD [Ex ia] IIC, [Ex iaD] [circuit(s) in zone 0/1/2/20/21/22]
Input		Ex ia, Ex iaD
Voltage	$U_o$	26 V
Current	$I_o$	93 mA
Power	$P_o$	605 mW
Supply		

Release date 2017-08-09 14:51 Date of issue 2017-08-10 196449\_eng.xml

Maximum safe voltage	$U_m$	253 V AC (Attention! $U_m$ is no rated voltage.)
Certificate		PF 10 CERT 1609 X
Marking		II 3G Ex nA IIC T4 Gc
Directive conformity		
Directive 2014/34/EU		EN 60079-0:2012+A11:2013 , EN 60079-11:2012 , EN 60079-15:2010
<b>International approvals</b>		
CSA approval		
Control drawing		366-005CS-12B (cCSAus)
IECEX approval		IECEX CES 10.0011
<b>General information</b>		
Supplementary information		Observe the certificates, declarations of conformity, instruction manuals, and manuals where applicable. For information see <a href="http://www.pepperl-fuchs.com">www.pepperl-fuchs.com</a> .

## Configuration

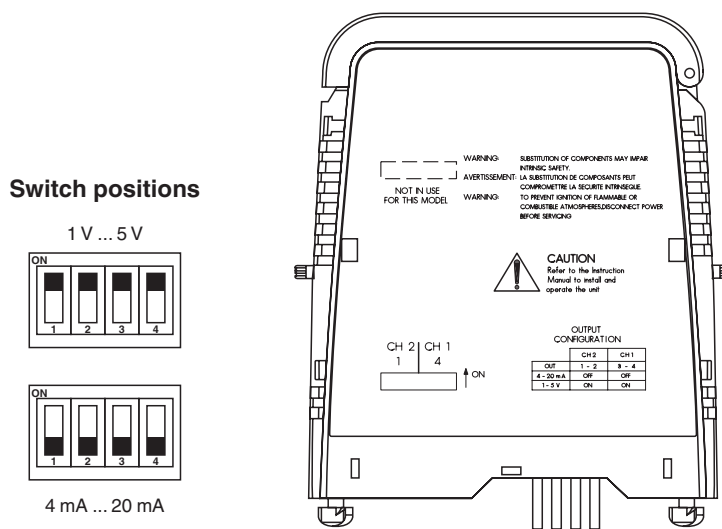

The outputs can be configured as:

- Current output 4 mA ... 20 mA
- Voltage output 1 V ... 5 V

Output	CH 1		CH 2 (only for HiD2026)	
	S4	S3	S2	S1
4 mA ... 20 mA	OFF	OFF	OFF	OFF
1 V ... 5 V	ON	ON	ON	ON



Channel 2 only for HiD2026.

Configure the device in the following way:

- Push the red Quick Lok Bars on each side of the device in the upper position.
- Remove the device from Termination Board.
- Set the DIP switches according to the figure.



The pins for this device are trimmed to polarize it according to its safety parameter. Do not change! For further information see system description.