

Datasheet - CSS 14-34-S-D-M-L

Safety sensors / CSS 34



Preferred typ



- Thermoplastic enclosure
- Electronic contact-free, coded system
- Misaligned actuation possible
- 27 mm x 108.2 mm x 35 mm
- High repeat accuracy of the switching points
- Max. length of the sensor chain 200 m
- 2 short-circuit proof PNP safety outputs
- Integral cross-short, wire-breakage and external voltage monitoring of the safety cables up to the control cabinet
- 1 x Pre-wired cable 8-pole
- Actuation from side
- Max. 31 sensors can be wired in series.

(Minor differences between the printed image and the original product may exist!)

Ordering details

Product type description	CSS 14-34-S-D-M-L
Article number	101181059
EAN Code	4030661314822
eCl@ss	27-27-24-01

Approval

Approval

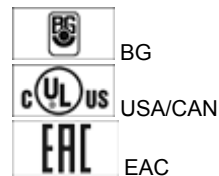

Classification

Standards	EN ISO 13849-1, IEC 61508, IEC 60947-5-3
PL	bis e
Control category	bis 4
PFH	3.6 x 10 ⁻⁹ /h
SIL	3 bis
Mission time	20 Years
Classification	PDF-M

Global Properties

Permanent light	CSS 34
Standards	IEC 60947-5-3
Compliance with the Directives (Y/N)	Yes

Suitable for safety functions (Y/N)	Yes
Function	Sensor for series wiring
Series-wiring	up to 31 components
Length of the sensor chain	max. 200 m
Active principle	inductive
Materials	
- Material of the housings	Plastic, glass-fibre reinforced thermoplastic
- Material of the active surface	Plastic, glass-fibre reinforced thermoplastic
Housing construction form	Block
Cable colour	Black
Cable type	LiYY
Weight	295
Input for enabling pushbutton, suitable for automatic start (Y/N)	No
Input for reset pushbutton, with edge monitoring (Y/N)	No
Diagnostic output (Y/N)	Yes
Reaction time	< 30
Duration of risk	< 60
Cascadable (Y/N)	Yes
Recommended actuator	CST 34-S-1, CST 34-S-2, CST 34-S-3, CST 180-1, CST 180-2

Mechanical data

Design of electrical connection	Cable (Y-UL 2517), 8-pole
Cable length	2
Cable section	
- Min. Cable section	
- Max. Cable section	8 x 0,35
AWG-Number	22
mechanical installation conditions	not flush
Actuating planes	Actuation from side
Active area	lateral
Switch distance S_n	10 mm / 14 mm
- Actuator CST 34-S-1	14
- Actuator CST 34-S-2	14
- Actuator CST 34-S-3	14
- Actuator CST 180-1 / CST 180-2	10
Ensured switch distance ON S_{ao}	8 mm / 12 mm
- Actuator CST 34-S-1	12
- Actuator CST 34-S-2	12
- Actuator CST 34-S-3	12
- Actuator CST 180-1 / CST 180-2	8
Ensured switch distance OFF S_{ar}	13 mm / 17 mm
- Actuator CST 34-S-1	17
- Actuator CST 34-S-2	17
- Actuator CST 34-S-3	17
- Actuator CST 180-1 / CST 180-2	13
hysteresis	max. 1.5 mm
Repeat accuracy R_R	$\leq 0,5$ mm
notice	Axial offset: The long side allows for a maximum height misalignment (x) of sensor and actuator of 36 mm (e.g. mounting tolerance or due to guard door sagging). Increased misalignment, max. 53 mm, possible when the CST 34-S-2 actuator is used. The axial misalignment (y) is max. ± 10 mm. see drawing: Operating principle
restistance to shock	30 g / 11 ms
Resistance to vibration	10 ... 55 HZ, Amplitude 1 mm

Ambient conditions

Ambient temperature	
- Min. environmental temperature	-25
- Max. environmental temperature	+70
Storage and transport temperature	
- Min. Storage and transport temperature	-25
- Max. Storage and transport temperature	+85
Protection class	IP65, IP67 to IEC/EN 60529
Protection rating	II
Air clearances and creepage distances To IEC/EN 60664-1	
- Rated impulse withstand voltage U_{imp}	0,8 kV
- Overvoltage category	III
- Degree of pollution	3

Electromagnetic compatibility (EMC)

EMC rating	to IEC 61000-6-2
Interfering radiation	to IEC 61000-6-4

Electrical data

Cross circuit/short circuit recognition possible (Y/N)	Yes
Voltage type	DC
Switch frequency	3
Rated insulation voltage U_i	32 VDC
Rated operating voltage U_e (stabilised PELV)	
Operating current I_e	0,6 A
No-load current I_0	0,1 A
Required rated short-circuit current	100 A
Device insulation (Circuit breaker)	
- Ambient temperature: up 45 °C	4 A
- Ambient temperature: up 60 °C	3.15 A
- Ambient temperature: 65 °C	2.5 A
- Ambient temperature: 70 °C	2 A
notice	The cable section of the interconnecting cable must be observed for both wiring variants! Cable length and cable section alter the voltage drop depending on the output current

Electrical data - Safety inputs

Safety inputs	X1 and X2
---------------	-----------

Electrical data - Safety outputs

Safety outputs	Y1 and Y2
Fuse rating	short-circuit proof
Design of control output	p-type
Number of secure semi-conductor outputs	2
Max. output current at secured output	0,25 A
Rated operating voltage	min. ($U_e - 1$ V)
Residual current I_r	$\leq 0,5$ mA
Operating current I_e	max. 0,25 A
- Ambient temperature: -25 °C ... +70 °C	$\leq 0,1$ A

Minimum operating current I_m	0,5 mA
- Ambient temperature: -25 °C ... +65 °C	≤ 0,25 A
Utilisation category	DC-12: 24 V / 0,25 A DC-13: 24 V / 0,25 A
Voltage drop U_d	< 1 V

Electrical data - Diagnostic output

Serial diagnostics (Y/N)	No
Fuse rating	short-circuit proof
Design of control output	p-type
Number of semi-conductor outputs with signaling function	1
Rated operating voltage	min. ($U_e - 5$ V)
Operating current I_e	max. 0,05 A
Voltage drop U_d	< 5 V
Utilisation category	DC-12: 24 V / 0,05 A DC-13: 24 V / 0,05 A

LED switching conditions display

LED switching conditions display (Y/N)	Yes
Number of LED's	3

ATEX

Explosion protection categories for gases	None
Explosion protected category for dusts	None

Dimensions

Dimensions of the sensor	
- Width of sensor	27
- Height of sensor	108.2
- Length of sensor	35

Pin assignment

1 - A1 U_e	Brown
2 - X1 Safety input 1	White
3 - A2 GND	Blue
4 - Y1 Safety output 1	Black
5 - OUT Diagnostic output OUT	Grey
6 - X2 Safety input 2	violet
7 - Y2 Safety output 2	red
8 - IN without function	Pink

notice

Requirements for the safety monitoring module	2-channel safety input, suitable for p-type sensors with NO function. The safety monitoring module must tolerate internal functional tests of the sensors with cyclic switch-off of the sensor outputs for max. 0,5 ms. The safety monitoring module does not need to have a cross-wire short monitoring function.
-----------------------------------------------	--------------------------------------------------------------------------------------------------------------------------------------------------------------------------------------------------------------------------------------------------------------------------------------------------------------------

Included in delivery

Actuators must be ordered separately.

Ordering code

CSS (1)-34-(2)-(3)-(4)-M-(5)

(1)	
12	Actuation from top
14	Actuation from side
(2)	
<i>without</i>	Included in standard versionversions
F0	Input for enabling pushbutton, suitable for automatic start
F1	Input for reset pushbutton, with edge monitoring
(3)	
S	Active area lateral
V	Active area front
(4)	
D	with Diagnostic output
SD	serial diagnostic output
(5)	
L	with Pre-wired cable
ST	with Connector

Documents

Operating instructions and Declaration of conformity (en) 383 kB, 24.09.2018

Code: mrl_css34_en

Operating instructions and Declaration of conformity (it) 379 kB, 24.09.2018

Code: mrl_css34_it

Operating instructions and Declaration of conformity (pt) 384 kB, 24.09.2018

Code: mrl_css34_pt

Operating instructions and Declaration of conformity (nl) 382 kB, 24.09.2018

Code: mrl_css34_nl

Operating instructions and Declaration of conformity (es) 386 kB, 24.09.2018

Code: mrl_css34_es

Operating instructions and Declaration of conformity (de) 365 kB, 24.09.2018

Code: mrl_css34_de

Operating instructions and Declaration of conformity (jp) 655 kB, 24.09.2018

Code: mrl_css34_jp

Operating instructions and Declaration of conformity (da) 373 kB, 22.08.2012

Code: mrl_css34_da

Operating instructions and Declaration of conformity (fr) 384 kB, 24.09.2018

Code: mrl_css34_fr

Operating instructions and Declaration of conformity (pl) 402 kB, 24.09.2018

Code: mrl_css34_pl

Wiring example (de) 148 kB, 29.09.2009

Code: kc33p02

Brochure (de) 6 MB, 15.02.2018

Code: b_css_brosch09_de

Brochure (en) 6 MB, 15.02.2018

Code: b_css_brosch09_en

TÜV certification (en, de) 599 kB, 26.03.2015

Code: z_cssp08

EAC certification (ru) 747 kB, 05.10.2015

Code: q_6396p17_ru

Images

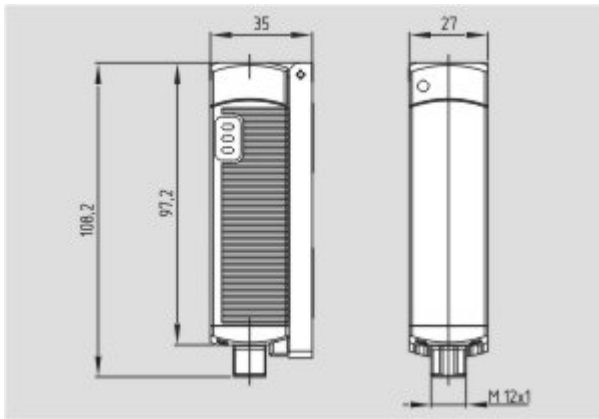

Dimensional drawing (basic component)

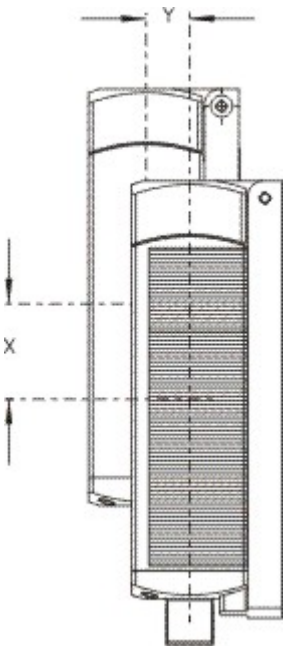

Operating principle



Clipart

System components

Actuator



101181085 - CST 34-S-1

- Actuation from side



101196101 - CST 34-S-2

- Actuator with double solenoid
- for increased misalignment
- Front and lateral actuation of the sensor possible



101203434 - CST 34-S-3

- Front and lateral actuation of the sensor possible
- Small body



101177198 - CST 180-1

- Front and lateral actuation of the sensor possible



101179574 - CST 180-2

- Front and lateral actuation of the sensor possible

Safety control modules

SRB031MC

- 1 Signalling output
- 3 safety contacts, STOP 1
- Drop-out delay can be set between 0,4 to 1,5 s



- Suitable for signal processing of potential-free outputs, e.g. emergency stop command devices, position switches and solenoid interlocks
- Suitable for signal processing of outputs connected to potentials (AOPDs), e.g. safety light grids/curtains
- Fit for signal evaluation of outputs of safety magnetic switches



SRB 301LC/B

- Fit for signal evaluation of outputs of safety magnetic switches (to this end, integrated current and voltage limiters)
- Suitable for signal processing of potential-free outputs, e.g. emergency stop command devices, position switches and solenoid interlocks
- Suitable for signal processing of outputs connected to potentials (AOPDs), e.g. safety light grids/curtains
- 3 safety contacts, STOP 0
- 1 Signalling output



SRB 301MC

- Fit for signal evaluation of outputs of safety magnetic switches
- 3 safety contacts, STOP 0
- 1 Signalling output
- Suitable for signal processing of outputs connected to potentials (AOPDs), e.g. safety light grids/curtains
- Suitable for signal processing of potential-free outputs, e.g. emergency stop command devices, position switches and solenoid interlocks



SRB301ST

- Suitable for signal processing of potential-free outputs, e.g. emergency stop command devices, position switches and solenoid interlocks
- Suitable for signal processing of outputs connected to potentials (AOPDs), e.g. safety light grids/curtains
- Fit for signal evaluation of outputs of safety magnetic switches
- 3 safety contacts, STOP 0
- 1 Signalling output



SRB304ST

- Suitable for signal processing of potential-free outputs, e.g. emergency stop command devices, position switches and solenoid interlocks
- Suitable for signal processing of outputs connected to potentials (AOPDs), e.g. safety light grids/curtains
- Fit for signal evaluation of outputs of safety magnetic switches
- 3 safety contacts, STOP 0
- 4 Signalling outputs



SRB324ST

- Suitable for signal processing of potential-free outputs, e.g. emergency stop command devices, position switches and solenoid interlocks
- Suitable for signal processing of outputs connected to potentials (AOPDs), e.g. safety light grids/curtains
- 3 safety contacts, STOP 0;
- 2 safety contacts, STOP 1 (adjustable 1 ... 30 s)
- 4 Signalling outputs
- Optional: Short-circuit recognition, Manual reset with edge detection in fail-safe circuit, Automatic reset function

101170036 - AES 1135

- Monitoring of BNS range magnetic safety sensors



- 1 safety contact, STOP 0
- 2 Signalling outputs



101170049 - AES 1235

- Monitoring of BNS range magnetic safety sensors
- 2 safety contacts, STOP 0
- 2 Signalling outputs

K.A. Schmersal GmbH & Co. KG, Möddinghofe 30, D-42279 Wuppertal

The data and values have been checked thoroughly. Technical modifications and errors excepted.

Generiert am 13.02.2019 - 14:28:40h Kasbase 3.3.0.F.64l