

## Datasheet - AZM300B-I2-ST-1P2P-A

Solenoid interlock / AZM300



- Suitable for mounting to profile systems
- Thermoplastic enclosure
- RFID-technology for needs-based protection against tampering
- 3 different directions of actuation
- Compact design
- 3 LEDs to show operating conditions
- Suitable for hinged and sliding guards
- Series-wiring
- Manual release
- Repeated individual coding with RFID technology
- Coding level "High" according to ISO 14119
- Connector M12, 8-pole
- Power to lock
- Actuator monitored
- Diagnostic output

(Minor differences between the printed image and the original product may exist!)

### Ordering details

Product type description	AZM300B-I2-ST-1P2P-A
Article number	103001427
EAN Code	
eCl@ss	27-27-26-03

### Approval

Approval

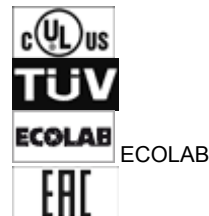

### Classification

Standards	EN ISO 13849-1, IEC 61508
PL	e
Control category	4
SIL	3
Mission time	20 Years
PFH value	$5.2 \times 10^{-10} / h$

## Global Properties

---

Permanent light	AZM300
Standards	EN 60947-5-1, IEC 60947-5-3, IEC 61508, EN ISO 13849-1
Compliance with the Directives (Y/N) 	Yes
Suitable for safety functions (Y/N)	Yes
Series-wiring	Yes
Length of the sensor chain	200
Active principle	RFID
Coding	Individual coding, multiple teaching
Coding levels according to ISO 14119	High
Duty cycle	100
Materials	
- Material of the housings	Plastic, glass-fibre reinforced thermoplastic
Housing coating	None
Weight	
Guard locking monitored (Y/N)	No
Actuator monitored (Y/N)	Yes
Idle assignable pushbutton and LED (Y/N)	No
Reaction time	< 120
Duration of risk	< 200
Time to readiness	5 s
Recommended actuator	AZ/AZM300-B1

## Mechanical data

---

Design of electrical connection	Connector M12, 8-pole, A-coded
Mechanical life	≥ 1.000.000 operations
notice - Mechanical life (when used as door stop)	≥ 50.000 operations for guards ≤ 5 kg; actuating speed ≤ 0,5 m/s
Switch distance	2
Ensured switch distance ON	1
Ensured switch distance OFF	20
restistance to shock	30 / 11
Resistance to vibration	10 ... 150 HZ, Amplitude 0,35 mm
Emergency unlocking device (Y/N)	No
Manual release (Y/N)	Yes
Emergency release (Y/N)	No
Latching (Y/N)	Yes
Latching force	25 / 50
Clamping force F	1150 N
Actuator and interlock misalignment	≤ 2
fixing screws	2 x M6

## Ambient conditions

---

Ambient temperature	
- Min. environmental temperature	0
- Max. environmental temperature	+60
Storage and transport temperature	
- Min. Storage and transport temperature	-10
- Max. Storage and transport temperature	+90
Protection class	IP66, IP67, IP69 to IEC 60529
Protection rating	II

Air clearances and creepage distances To IEC/EN 60664-1

- Rated impulse withstand voltage	0,8
- Overvoltage category	III
- Degree of pollution	3

### Electrical data

---

Number of auxiliary contacts	0
Number of safety contacts	2
Cross circuit/short circuit recognition possible (Y/N)	Yes
Power to unlock	No
Power to lock	Yes
Supply voltage (stabilised PELV)	24 -15 / +10
Switch frequency	0,5
Operating current	100 (without load)
Rated insulation voltage	32 VDC
Operating current $I_e$	1 A
Utilisation category	DC-13
Required rated short-circuit current	100 A
Device insulation	2 A
notice	Cable length and cable section alter the voltage drop depending on the output current

### Electrical data - Safety inputs

---

Safety inputs	X1 and X2
Switching thresholds	-3 ... 5 ( Low) 15 ... 30 ( High)
Operating current	5 mA / 24 V

### Electrical data - Safety outputs

---

Safety outputs	Y1 and Y2
Design of control output	short-circuit proof, p-type
Rated operating voltage	0 ... 4 under Supply voltage
Residual current	$\leq 0,5$
Operating current	0,25 A
Utilisation category	DC-12, DC-13
Test impulse width	$< 0,5$
Test frequency	1

### Electrical data - Diagnostic output

---

Serial diagnostics (Y/N)	No
Design of control output	short-circuit proof, p-type
Rated operating voltage $U_e$	0 V ... 4 V under Supply voltage $U_B$
Operating current	0,05 A
Utilisation category	DC-12, DC-13
Wiring capacitance for serial diagnostics	-
diagnostic signals	guard door closed and interlocking device locked
Operating principle of the diagnostic output	The short-circuit proof diagnostic output OUT can be used for central visualisation or control tasks, e.g. in a PLC.
notice	The diagnostic output is not a safety-relevant output!

### Electrical data - Solenoid control IN

---

Switching thresholds	-3 ... 5 (Low) 15 ... 30 (High)
Operating current	10 mA / 24 V

### LED switching conditions display

---

LED switching conditions display (Y/N)	Yes
LED switching conditions display	
- Supply voltage	green LED
- switching condition	yellow LED
- Error functional defect	red LED

### ATEX

---

Explosion protection categories for gases	None
Explosion protected category for dusts	None

### Dimensions

---

Dimensions of the sensor	
- Width of sensor	85
- Height of sensor	100
- Length of sensor	35

### Pin assignment

---

1	A1 Supply voltage
2	X1 Safety input 1
3	A2 GND
4	Y1 Safety output 1
5	OUT Diagnostic output
6	X2 Safety input 2
7	Y2 Safety output 2
8	IN Solenoid control

### notice

---

As long as the actuating unit remains inserted in the solenoid interlock, the unlocked safety guard can be relocked. The safety outputs then will be enabled again; opening the safety guard therefore is not required.

For doors that are flush with the door frame, the optional mounting plate MP-AZ/AZM300-1 can be used.

For glass and Makrolon doors, the optional mounting kit MS-AZ/AZM300-B1-1 can be used.

### Included in delivery

---

Actuators must be ordered separately.

### Ordering code

---

AZM300(1)(2)-ST(3)-(4)-(5)

(1)

Z Guard locking monitored

B Actuator monitored

<b>(2)</b>		
<i>without</i>		Included in standard version coding
<b>I1</b>		Individual coding
<b>I2</b>		Individual coding, multiple teaching
<b>(3)</b>		
<b>1P2P</b>		1 Diagnostic output, p-type and 2 Safety outputs, p-type
<b>SD2P</b>		serial diagnostic output and 2 Safety outputs, p-type
<b>(4)</b>		
<i>without</i>		Power to unlock
<b>A</b>		Power to lock
<b>(5)</b>		
<i>without</i>		Manual release
<b>T</b>		Emergency exit
<b>N</b>		Emergency release

## Documents

---

**Operating instructions and Declaration of conformity (jp)** 1 MB, 18.09.2017

Code: mrl\_azm300\_jp

**Operating instructions and Declaration of conformity (it)** 1 MB, 11.07.2018

Code: mrl\_azm300\_it

**Operating instructions and Declaration of conformity (sv)** 1 MB, 18.09.2017

Code: mrl\_azm300\_sv

**Operating instructions and Declaration of conformity (en)** 1 MB, 18.06.2018

Code: mrl\_azm300\_en

**Operating instructions and Declaration of conformity (da)** 1 MB, 18.09.2017

Code: mrl\_azm300\_da

**Operating instructions and Declaration of conformity (cn)** 1 MB, 22.11.2018

Code: mrl\_azm300\_cn

**Operating instructions and Declaration of conformity (es)** 1 MB, 01.08.2018

Code: mrl\_azm300\_es

**Operating instructions and Declaration of conformity (de)** 1 MB, 18.06.2018

Code: mrl\_azm300\_de

**Operating instructions and Declaration of conformity (fr)** 1 MB, 01.08.2018

Code: mrl\_azm300\_fr

**Operating instructions and Declaration of conformity (nl)** 1 MB, 01.08.2018

Code: mrl\_azm300\_nl

**Operating instructions and Declaration of conformity (pt)** 1 MB, 01.08.2018

Code: mrl\_azm300\_pt

**Operating instructions and Declaration of conformity (pl)** 1 MB, 21.11.2018

Code: mrl\_azm300\_pl

**Brochure (it)** 877 kB, 29.04.2016

Code: b\_azm300p01\_it

**Brochure** (en) 857 kB, 23.07.2015

Code: b\_azm300p01\_en

**Brochure** (de) 863 kB, 23.07.2015

Code: b\_azm300p01\_de

**Brochure** (es) 2 MB, 03.05.2013

Code: b\_azm300p01\_es

**Brochure** (jp) 1 MB, 13.03.2013

Code: b\_azm300p01\_jp

**Brochure** (pt) 1 MB, 03.05.2013

Code: b\_azm300p01\_pt

**Brochure** (fr) 2 MB, 03.05.2013

Code: b\_azm300p01\_fr

**Brochure** (br) 2 MB, 08.03.2013

Code: b\_azm300p01\_br

**Brochure** (br) 2 MB, 03.05.2013

Code: b\_azm300p01\_br

**Brochure** (nl) 1 MB, 03.05.2013

Code: b\_azm300p01\_nl

**Brochure** (cs) 2 MB, 03.05.2013

Code: b\_azm300p01\_cs

**Brochure** (pl) 2 MB, 03.05.2013

Code: b\_azm300p01\_pl

**Brochure** (de) 6 MB, 15.02.2018

Code: b\_css\_brosch09\_de

**Brochure** (en) 6 MB, 15.02.2018

Code: b\_css\_brosch09\_en

**TÜV certification** (de, en) 761 kB, 17.09.2018

Code: z\_azmp05

**EAC certification** (ru) 809 kB, 05.10.2015

Code: q\_6040p17\_ru

**ECOLAB certification** (en) 94 kB, 08.04.2013

Code: q\_azmp03

**ECOLAB certification** (de) 93 kB, 08.04.2013

Code: q\_azmp02

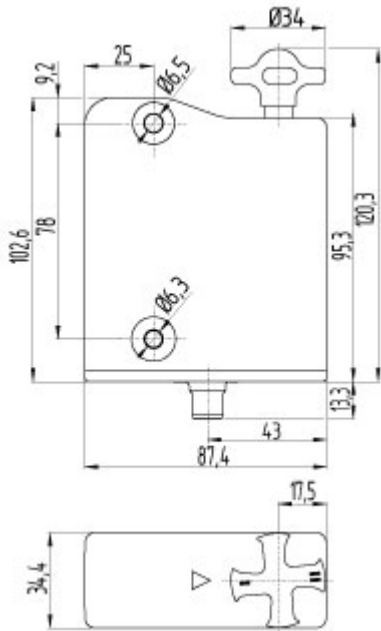

Dimensional drawing (basic component)

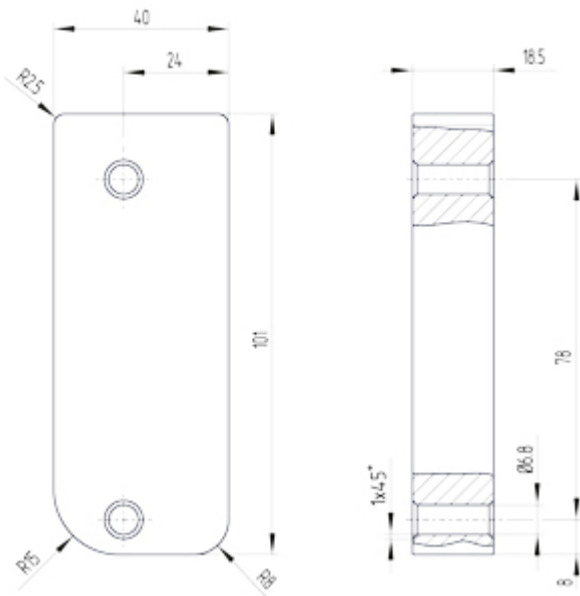

Dimensional drawing (miscellaneous)

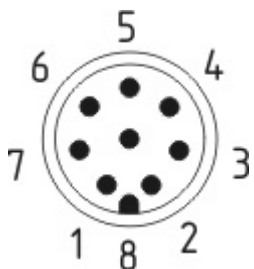

Contact arrangement

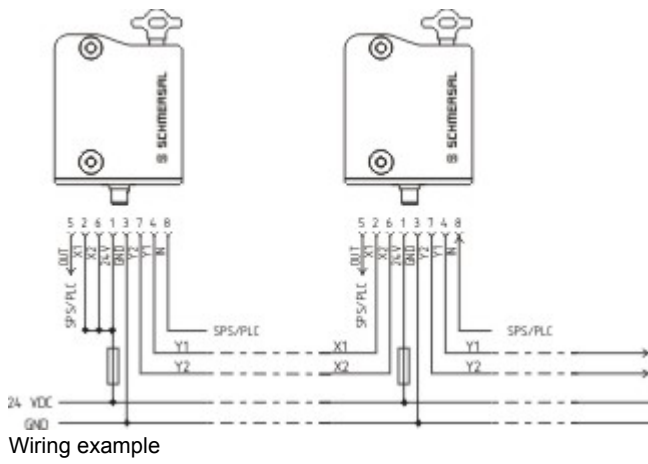

## System components

### Actuator



**101218025 - AZ/AZM300-B1**

- 3 different directions of actuation

### Accessories



**103002891 - MS-AZ/AZM300-B1-1**



**103003172 - MP-AZ/AZM300-1**

K.A. Schmersal GmbH & Co. KG, Möddinghofe 30, D-42279 Wuppertal

The data and values have been checked thoroughly. Technical modifications and errors excepted.

Generiert am 13.02.2019 - 14:50:57h Kasbase 3.3.0.F.64I