

Datasheet - SRB400CS/T 24VDC



Guard door monitors and Safety control modules for Emergency Stop applications / General Purpose safety controllers (Series PROTECT SRB) / SRB400C.



- Two-functions safety monitoring module (double evaluation)
- 2 x 2 enabling paths with different shut-down behaviour, e.g. emergency exit opens both enabling paths (level 1); guard door monitoring only opens the second enabling path (level 2)
- Suitable for signal processing of potential-free contacts, e.g. Emergency Stop command devices (level 1), position switches with safety function, solenoid interlocks and safety sensors (level 2)
- Level 1: Reset with edge detection, Level 2: / Opener (NC) Opener (NC)

(Minor differences between the printed image and the original product may exist!)

Ordering details

Product type description	SRB400CS/T 24VDC
Article number	101176211
EAN Code	4250116201921
Replaced article number 101177161	
eCl@ss	27-37-19-01

Approval

Approval



Classification

Standards	EN ISO 13849-1, IEC 61508, EN 60947-5-1
PL	up e (STOP 0)
Control category	up 4 (STOP 0)
DC	99% (STOP 0)
CCF	> 65 points
PFH value	$\leq 2,0 \times 10^{-8}/h$ (STOP 0)
SIL	up 3 (STOP 0)
Mission time	20 Years

- notice

The PFH value is applicable for the combinations listed in the table for contact load (K) (current through enabling paths) and switching cycle number (n-op/y).

In case of 365 operating days per year and a 24-hour operation, this results in the specified switching cycle times (t-cycle) for the relay contacts.

Diverging applications on request.

K	n-op/y	t-cycle
20 %	525.600	1,0 min
40 %	210.240	2,5 min
60 %	75.067	7,0 min
80 %	30.918	17,0 min
100 %	12.223	43,0 min

Global Properties

Permanent light	SRB400CS/T 24VDC
Standards	IEC/EN 60204-1, EN 60947-5-1, EN ISO 13849-1, IEC 61508
Compliance with the Directives (Y/N) 	Yes
Climatic stress	EN 60068-2-78
Mounting	snaps onto standard DIN rail to EN 60715
Terminal designations	IEC/EN 60947-1
Materials	
- Material of the housings	Plastic, glass-fibre reinforced thermoplastic, ventilated
- Material of the contacts	Ag-Ni, self-cleaning, positive action
Weight	346
Start conditions	Automatic or Start button
Start input (Y/N)	Yes
Feedback circuit (Y/N)	Yes
Automatic reset function	No
Reset with edge detection (Y/N)	Yes (Level 1)
Pull-in delay	
- ON delay with reset button	typ. 40 ms (Level 1) typ. 500 ms (Level 2)
Drop-out delay	
- Drop-out delay in case of emergency stop	typ. 50 ms

Mechanical data

Connection type	Screw connection
Cable section	
- Min. Cable section	0,25
- Max. Cable section	2.5
Pre-wired cable	rigid or flexible
Tightening torque for the terminals	0,6
Detachable terminals (Y/N)	Yes
Mechanical life	10.000.000 operations
Electrical lifetime	Derating curve available on request
resistance to shock	10 g / 11 ms
Resistance to vibration To EN 60068-2-6	10...55 HZ, Amplitude 0,35 mm

Ambient conditions

Ambient temperature	
- Min. environmental temperature	-25 °C
- Max. environmental temperature	+45 °C
Storage and transport temperature	
- Min. Storage and transport temperature	-40 °C

- Max. Storage and transport temperature	+85 °C
Protection class	
- Protection class-Enclosure	IP40
- Protection class-Terminals	IP20
- Protection class-Clearance	IP54
Air clearances and creepage distances To IEC/EN 60664-1	
- Rated impulse withstand voltage U_{imp}	4 kV
- Overvoltage category	III To VDE 0110
- Degree of pollution	2 To VDE 0110

Electromagnetic compatibility (EMC)

EMC rating	conforming to EMC Directive
------------	-----------------------------

Electrical data

Rated DC voltage for controls	
- Max. rated DC voltage for controls	20.4 VDC
- Max. rated DC voltage for controls	28.8 VDC
Rated AC voltage for controls, 50 Hz	
- Min. rated AC voltage for controls, 50 Hz	-
- Max. rated AC voltage for controls, 50 Hz	-
Rated AC voltage for controls, 60 Hz	
- Min. rated AC voltage for controls, 60 Hz	-
- Max. rated AC voltage for controls, 60 Hz	-
Contact resistance	max. 100 mΩ
Power consumption	4.4
Type of actuation	DC
Rated operating voltage U_e	24 VDC -15% / +20%, residual ripple max. 10%
Operating current I_e	0,18 A
Electronic protection (Y/N)	Yes
Fuse rating for the operating voltage	Internal electronic trip, tripping current > 1.0 A, Reset after approximately 1 second/s
Current and tension on control circuits	
- S31, S32, S41, S42	26 VDC, Test current: 100 mA

Inputs

Monitored inputs

- Short-circuit recognition (Y/N)	No (Level 1)
- Wire breakage detection (Y/N)	Yes
- Earth connection detection (Y/N)	Yes
Number of shutters	2
Number of openers	2
Cable length	1-channel without cross-wire detection: 1500 m with 1.5 mm ² ; 2500 m with 2.5 mm ² ; 2-channel with/ without cross-wire detection
Conduction resistance	max. 40 Ω

Outputs

- Stop category 1	Residual current at ambient temperature up to: - 45°C = 12 A; - 55°C = 10 A; - 60°C = 8 A
Stop category	0

- Stop category 0	Residual current at ambient temperature up to: - 45°C = 18 A; - 55°C = 15 A; - 60°C = 12 A
Number of safety contacts	4 piece
Number of auxiliary contacts	0 piece
Number of signalling outputs	0 piece
Switching capacity	
- Switching capacity of the safety contacts	max. 230 VAC, 4 A ohmic (inductive in case of appropriate protective wiring)
Fuse rating	
- Protection of the safety contacts	4 A slow blow
Utilisation category To EN 60947-5-1	AC-15: 230 V / 1,5 A DC-13: 24 V / 1,2 A
Note on the utilisation category	
Number of undelayed semi-conductor outputs with signaling function	0 piece
Number of undelayed outputs with signaling function (with contact)	0 piece
Number of delayed semi-conductor outputs with signaling function.	0 piece
Number of delayed outputs with signalling function (with contact).	0 piece
Number of secure undelayed semi-conductor outputs with signaling function	0 piece
Number of secure, undelayed outputs with signaling function, with contact.	4 piece
Number of secure, delayed semi-conductor outputs with signaling function	0 piece
Number of secure, delayed outputs with signaling function (with contact).	0 piece

LED switching conditions display

LED switching conditions display (Y/N)	Yes
Number of LED's	6
LED switching conditions display	
- The integrated LEDs indicate the following operating states.	
- Position relay K4	
- Position relay K1	
- Position relay K2	
- Position relay K3	
- Supply voltage	
- Internal operating voltage Ui	

Miscellaneous data

Applications	 Guard system  Emergency-Stop button  Pull-wire emergency stop switches  Safety sensor
--------------	---

Dimensions

Dimensions	
- Width	22.5 mm
- Height	100 mm
- Depth	121 mm

notice

Inductive loads (e.g. contactors, relays, etc.) are to be suppressed by means of a suitable circuit.

notice - Wiring example

Input level: the example shows a 2-channel control of an Emergency Stop command device (level 1) with external reset button (R), and guard door monitoring (level 2) with feedback circuit (H2).

The control recognises cross-short, cable break and earth leakages in the monitoring circuit.

Relay outputs: Suitable for 2 channel control, for increase in capacity or number of contacts by means of contactors or relays with positive-guided contacts.

Automatic start:

Level 1: the automatic start is programmed by connecting the feedback circuit to the terminals X1/+24VDC.

Level 2: the automatic start is programmed by connecting the feedback circuit to the terminals X2/+24VDC.

If the feedback circuit is not required, establish a bridge

The wiring diagram is shown with guard doors closed and in de-energised condition.

Documents

Operating instructions and Declaration of conformity (pt) 918 kB, 29.11.2017

Code: mrl_srb400c_pt

Operating instructions and Declaration of conformity (nl) 912 kB, 29.11.2017

Code: mrl_srb400c_nl

Operating instructions and Declaration of conformity (jp) 1 MB, 15.04.2014

Code: mrl_srb400c_jp

Operating instructions and Declaration of conformity (es) 912 kB, 23.11.2017

Code: mrl_srb400c_es

Operating instructions and Declaration of conformity (pl) 934 kB, 29.11.2017

Code: mrl_srb400c_pl

Operating instructions and Declaration of conformity (de) 897 kB, 15.11.2017

Code: mrl_srb400c_de

Operating instructions and Declaration of conformity (fr) 914 kB, 24.11.2017

Code: mrl_srb400c_fr

Operating instructions and Declaration of conformity (da) 913 kB, 21.11.2017

Code: mrl_srb400c_da

Operating instructions and Declaration of conformity (it) 913 kB, 29.11.2017

Code: mrl_srb400c_it

Operating instructions and Declaration of conformity (en) 892 kB, 15.11.2017

Code: mrl_srb400c_en

Wiring example (99) 21 kB, 04.08.2008

Code: ksr401

EAC certification (ru) 1 MB, 15.03.2018

Code: q_aesp01

Images

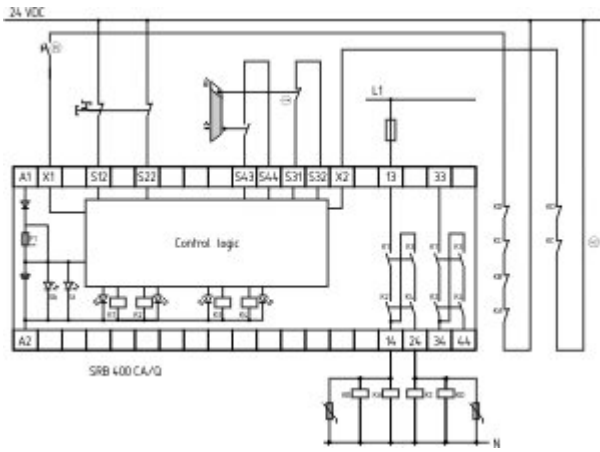

Wiring example

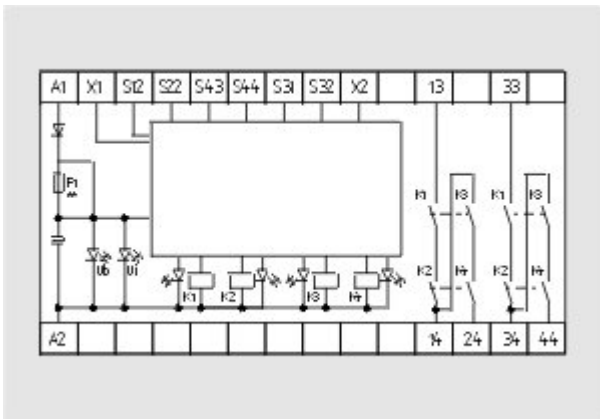

Internal wiring diagram

K.A. Schmersal GmbH & Co. KG, Möddinghofe 30, D-42279 Wuppertal

The data and values have been checked thoroughly. Technical modifications and errors excepted.

Generiert am 13.02.2019 - 13:03:53h Kasbase 3.3.0.F.64I