

2D/3D Profile Sensor

MLWL201

LASER

weCat3D

Part Number



- Optimized profile quality thanks to HDR function
- Precise measuring range resolution X (> 2000 measuring points)
- Up to 12 million measuring points per second

2D/3D Profile Sensors project a laser line onto the object to be detected and generate an accurate, linearized height profile with an internal camera which is set up at a triangulation angle. Thanks to its uniform, open interface, the weCat3D series can be incorporated by means of the DLL program library or the GigE Vision standard without an additional control unit. Alternatively, wenglor offers its own software packages for implementing your application.

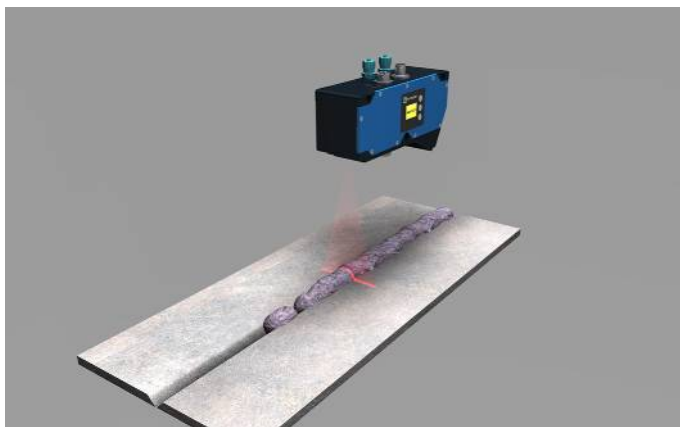

Technical Data

Optical Data	
Working range Z	120...300 mm
Measuring range Z	180 mm
Measuring range X	65...145 mm
Linearity Deviation	45 µm
Resolution Z	5,2...26 µm
Resolution X	36...81 µm
Light Source	Laser (red)
Wavelength	660 nm
Service Life (T = +25 °C)	20000 h
Laser Class (EN 60825-1)	1M
Max. Ambient Light	5000 Lux
Electrical Data	
Supply Voltage	18...30 V DC
Current Consumption (U _b = 24 V)	300 mA
Measuring Rate	175...6000 /s
Temperature Range	0...45 °C
Storage temperature	-20...70 °C
Inputs/Outputs	4
Switching Output Voltage Drop	< 1,5 V
Switching Output/Switching Current	100 mA
Short Circuit Protection	yes
Reverse Polarity Protection	yes
Overload Protection	yes
Interface	Ethernet TCP/IP
Baud Rate	100/1000 Mbit/s
Protection Class	III
Mechanical Data	
Housing Material	Aluminum
Degree of Protection	IP67
Connection	M12 × 1; 12-pin
Type of Connection Ethernet	M12 × 1; 8-pin, X-cod.
Optic Cover	Glass
Weight	580 g
Web server	yes

Configurable as PNP/NPN/Push-Pull	<input checked="" type="radio"/>
Switchable to NC/NO	<input checked="" type="radio"/>
Connection Diagram No.	1022 1023
Control Panel No.	X2 A22
Suitable Connection Equipment No.	50 87
Suitable Mounting Technology No.	343

Display brightness may decrease with age. This does not result in any impairment of the sensor function.

Complementary Products

Control Unit
Cooling Unit ZLWK004
Protective Screen Retainer ZLWS004
Software
Switch ZAC45FN01

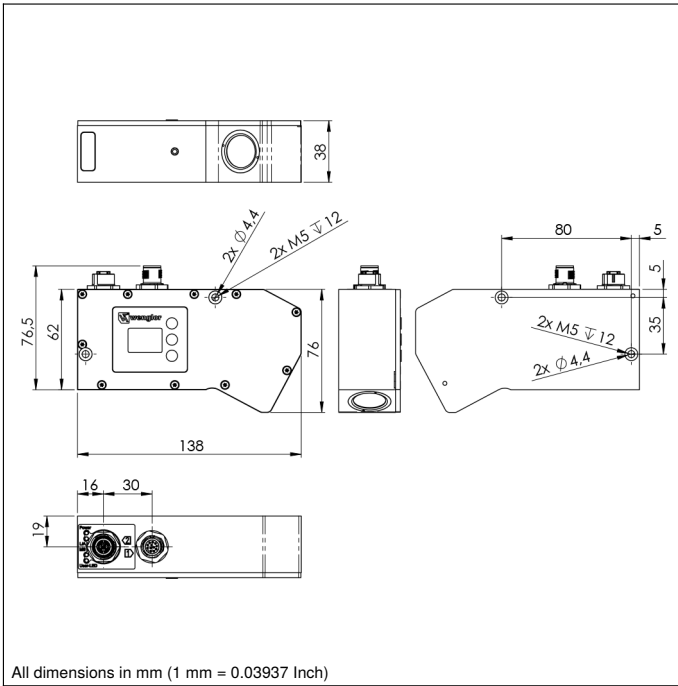

Ctrl. Panel

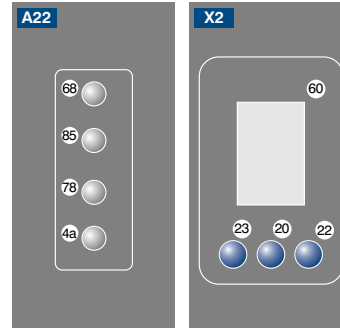

- 20 = Enter Button
- 22 = UP Button
- 23 = Down Button
- 4a = User LED
- 60 = Display
- 68 = Supply Voltage Indicator
- 78 = Module status
- 85 = Link/Act LED

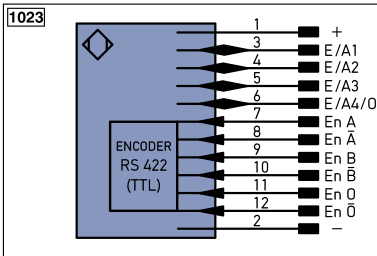
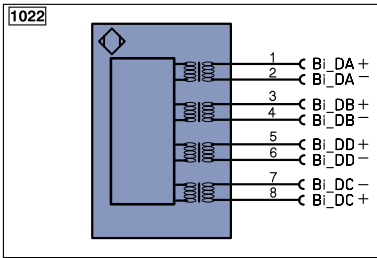

Legend

+	Supply Voltage +	PT	Platinum measuring resistor	ENa	Encoder A
-	Supply Voltage 0 V	nc	not connected	ENb	Encoder B
~	Supply Voltage (AC Voltage)	U	Test Input	AMIN	Digital output MIN
A	Switching Output (NO)	Ū	Test Input inverted	AMAX	Digital output MAX
Ā	Switching Output (NC)	W	Trigger Input	AOK	Digital output OK
V	Contamination/Error Output (NO)	O	Analog Output	SY In	Synchronization In
Ṽ	Contamination/Error Output (NC)	O-	Ground for the Analog Output	SY OUT	Synchronization OUT
E	Input (analog or digital)	BZ	Block Discharge	0.Lt	Brightness output
T	Teach Input	AWV	Valve Output	M	Maintenance
Z	Time Delay (activation)	a	Valve Control Output +	rsv	reserved
S	Shielding	b	Valve Control Output 0 V		
RxD	Interface Receive Path	SY	Synchronization		
TxD	Interface Send Path	E+	Receiver-Line		
RDY	Ready	S+	Emitter-Line		
GND	Ground	±	Grounding		
CL	Clock	SnR	Switching Distance Reduction		
E/A	Output/Input programmable	Rx+/-	Ethernet Receive Path		
IO-Link	IO-Link	Tx+/-	Ethernet Send Path		
PoE	Power over Ethernet	Bus	Interfaces-Bus A(+)/B(-)		
IN	Safety Input	La	Emitted Light disengageable		
OSSD	Safety Output	Mag	Magnet activation		
Signal	Signal Output	RES	Input confirmation		
Bi_D+/-	Ethernet Gigabit bidirect. data line (A-D)	EDM	Contactur Monitoring		
EN0 RS422	Encoder 0-pulse 0-0̄ (TTL)	ENaRS422	Encoder A/Ā (TTL)		
		ENbRS422	Encoder B/B̄ (TTL)		

Wire Colors according to DIN IEC 757

BK	Black
BN	Brown
RD	Red
OG	Orange
YE	Yellow
GN	Green
BU	Blue
VT	Violet
GY	Grey
WH	White
PK	Pink
GNYE	Green/Yellow

Measuring field X, Z

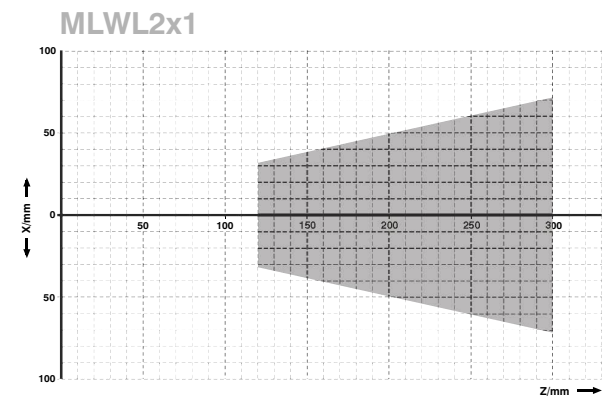

Z = Working distance

X = Measuring Range

