

# Spotlight

## ZFSI10-01

Part Number



- Flashlight mode synchronizable with image processing
- High illumination intensity

### Technical Data

Optical Data	
Light Source	Infrared Light
Wave Length	850 nm
Risk Group (EN 62471)	1
Electrical Data	
Supply Voltage	18...30 V DC
Current Consumption (U <sub>b</sub> = 24 V)	< 600 mA
Temperature Range	0...60 °C
Reverse Polarity Protection	yes
Protection Class	III
Mechanical Data	
Housing Material	Plastic, AL
Degree of Protection	IP42
Connection	M12 × 1; 4-pin
Connection Diagram No.	749
Connection Table No.	32
Suitable Connection Technology No.	2
Suitable Mounting Technology No.	470   480

The wenglor spotlight illuminates the application evenly. Edges, contours and drill holes can be detected reliably. In the case of inclined mounting also reflecting objects are illuminated well.

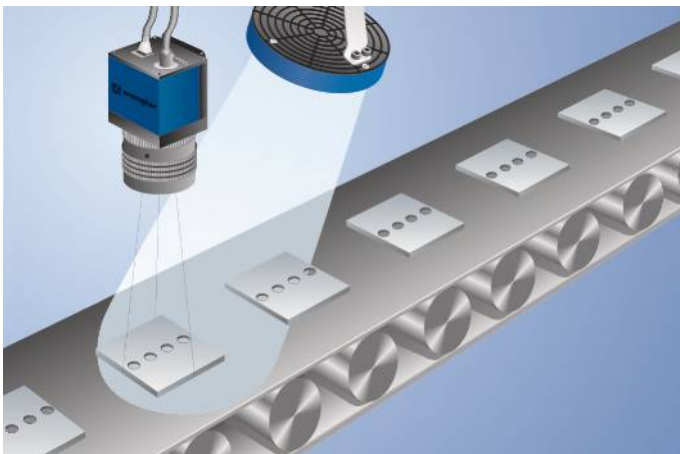

### Complementary Products

Connection Cable BG2BSW1-08M, ZAV89V901, ZDCG001  
Polarization Filter ZNNG010, ZVPOF1001

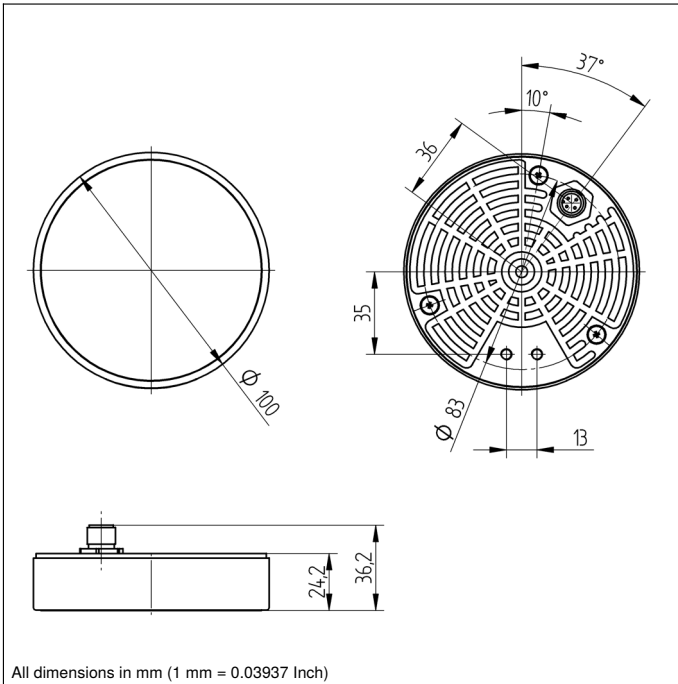

All dimensions in mm (1 mm = 0.03937 Inch)

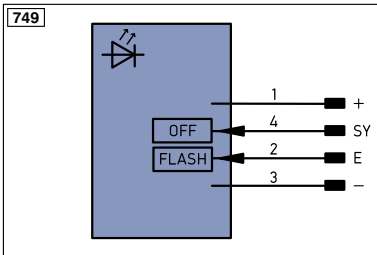

#### Legend

+	Supply Voltage +
-	Supply Voltage 0 V
~	Supply Voltage (AC Voltage)
A	Switching Output (NO)
Ā	Switching Output (NC)
V	Contamination/Error Output (NO)
V̄	Contamination/Error Output (NC)
E	Input (analog or digital)
T	Teach Input
Z	Time Delay (activation)
S	Shielding
RxD	Interface Receive Path
TxD	Interface Send Path
RDY	Ready
GND	Ground
CL	Clock
E/A	Output/Input programmable
	IO-Link
PoE	Power over Ethernet
IN	Safety Input
OSSD	Safety Output
Signal	Signal Output
Bl..D +/-	Ethernet Gigabit bidirect. data line (A-D)
EN0_0542	Encoder 0-pulse 0-0 (TTL)
PT	Platinum measuring resistor
nc	not connected
U	Test Input
Ū	Test Input inverted
W	Trigger Input
O	Analog Output
O-	Ground for the Analog Output
BZ	Block Discharge
AwV	Valve Output
a	Valve Control Output +
b	Valve Control Output 0 V
SY	Synchronization
E+	Receiver-Line
S+	Emitter-Line
≡	Grounding
SnR	Switching Distance Reduction
Rx +/-	Ethernet Receive Path
Tx +/-	Ethernet Send Path
Bus	Interfaces-Bus A(+)/B(-)
La	Emitted Light disengageable
Mag	Magnet activation
RES	Input confirmation
EDM	Contactorm Monitoring
ENAR542	Encoder A/Ā (TTL)
ENBR542	Encoder B/B̄ (TTL)

ENa	Encoder A
ENb	Encoder B
AMIN	Digital output MIN
AMAX	Digital output MAX
AOK	Digital output OK
SY In	Synchronization In
SY OUT	Synchronization OUT
Out	Brightness output
M	Maintenance

#### Wire Colors according to DIN IEC 757

BK	Black
BN	Brown
RD	Red
OG	Orange
YE	Yellow
GN	Green
BU	Blue
VT	Violet
GY	Grey
WH	White
PK	Pink
GNYE	Green/Yellow

