

Incremental encoders

With blind hollow shaft

1...65536 pulses per revolution programmable (interpolated system)

ExEIL580P-B



ExEIL580P-B with blind hollow shaft

Features

- Size $\varnothing 58$ mm
- Precise optical sensing (interpolated)
- Output signal level programmable (TTL or HTL)
- Blind hollow shaft, $\varnothing 8...15$ mm
- Connection axial, radial or tangential
- Pulses per revolution 1...65536, programmable
- High resistance to shock and vibrations
- Option 0122, Explosion protection zone 22

Technical data - electrical ratings

Voltage supply	4.75...30 VDC
Reverse polarity protection	Yes
Short-circuit proof	Yes
Consumption w/o load	≤ 70 mA
Initializing time	≤ 30 ms after power on
Pulses per revolution	1...65536
Duty cycle	45...55 % typical at 1024, 2048 ppr (further see table Duty cycle)
Reference signal	Zero pulse 90° or 180°
Sensing method	Optical
Output frequency	≤ 300 kHz (TTL) ≤ 160 kHz (HTL)
Output signals	A+, B+, R+, A-, B-, R-
Output stages	TTL/RS422 HTL/push-pull
Programmable parameters	Output level TTL/HTL Pulse number 1...65536 Zero pulse width $90^\circ/180^\circ$ Zero pulse position Signal sequence
Interference immunity	DIN EN 61000-6-2
Emitted interference	DIN EN 61000-6-3
Approval	UL 508 / CSA 22.2

Technical data - mechanical design

Size (flange)	$\varnothing 58$ mm
Shaft type	$\varnothing 8...15$ mm (blind hollow shaft)
Protection DIN EN 60529	IP 65
Operating speed	≤ 8000 rpm ($+20^\circ\text{C}$) ≤ 8000 rpm ($+40^\circ\text{C}$) ≤ 5000 rpm ($+60^\circ\text{C}$)
Starting torque	≤ 0.02 Nm ($+20^\circ\text{C}$)
Materials	Housing: aluminium die-cast Flange: aluminium
Ambient temperature	$-20...+60^\circ\text{C}$
Relative humidity	90 % non-condensing
Resistance	DIN EN 60068-2-6 Vibration 30 g, 10-2000 Hz DIN EN 60068-2-27 Shock 250 g, 6 ms
Explosion protection	II 3 D Ex tc IIIC T135°C Dc X (dust): see special conditions "X"
Connection	Flange connector M12, 8-pin Flange connector M23, 12-pin Cable
Weight approx.	300 g

Incremental encoders

With blind hollow shaft

1...65536 pulses per revolution programmable (interpolated system)

ExEIL580P-B

Part number

ExEIL580P- **B** . **5** **F** . **01024** **.F/** **0122**

Option

0122 ATEX Zone 22

Pulses programmable

01024 1...65536 programmable (factory setting: 1024)

Voltage supply / output stages

F 4.75...30 VDC, TTL/RS422, 6 channel (Vout = 5 VDC) - Factory setting
HTL/push-pull 6 channel (Vout = Vin) - programmable by customer

Connection

- R Cable radial, 1 m
- L Cable radial, 2 m
- F Flange connector M23, 12-pin, radial, male, CCW
- B Flange connector M12, 8-pin, radial, male, CCW
- T Cable axial, 1 m
- U Cable axial, 2 m
- D Flange connector M23, 12-pin, axial, male, CCW
- A Flange connector M12, 8-pin, axial, male, CCW
- P Cable tangential, 1 m
- Q Cable tangential, 2 m

Protection

5 IP 65

Specification hollow shaft

- | | |
|---|---|
| 08 ø8 mm, clamping ring at A side | U4 ø1/2" (12.7 mm), clamping ring at A side |
| U3 ø3/8" (9,52 mm), clamping ring at A side | 14 ø14 mm, clamping ring at A side |
| 10 ø10 mm, clamping ring at A side | 15 ø15 mm, clamping ring at A side |
| 12 ø12 mm, clamping ring at A side | |

Flange

- N Without stator coupling
- T With stator coupling ø63 mm
- P Torque pin 3 mm, axial/radial

Shaft type

- B Blind hollow shaft

(Factory setting: 1024 ppr, Vout = 5 VDC TTL, signal sequence A leading B (CW), zero pulse 90° A&B high)

Subject to modification in technic and design. Errors and omissions excepted.

Incremental encoders

With blind hollow shaft

1...65536 pulses per revolution programmable (interpolated system)

ExEIL580P-B

Accessories

Connectors and cables

10127844	Connection cable 2 m shielded with female connector M12, 8-pin, straight (ESG 34FH0200G)
10129332	Connection cable 5 m shielded with female connector M12, 8-pin, straight (ESG 34FH0500G)
10129333	Connection cable 10 m shielded with female connector M12, 8-pin, straight (ESG 34FH1000G)
11053961	Connection cable 2 m shielded with female connector M12, 8-pin, angled (ESW 33FH0200G)
11053962	Connection cable 5 m shielded with female connector M12, 8-pin, angled (ESW 33FH0500G)
10170054	Connection cable 10 m shielded with female connector M12, 8-pin, angled (ESW 33FH1000G)
10164705	Connector M23, 12-pin
11095302	Connection cable 1 m shielded with female connector M23, 12-pin
11100408	Connection cable 2 m shielded with female connector M23, 12-pin
11100430	Connection cable 5 m shielded with female connector M23, 12-pin
11100431	Connection cable 10 m shielded with female connector M23, 12-pin
11119280	Connection cable connector M12 / connector D-SUB, 0.2 m
11119720	Connection cable connector M12 / connector D-SUB, 1 m
11119257	Connection cable connector M23 / connector D-SUB, 0.2 m (S2BG12/K4SG9)
11119723	Connection cable connector M23 / connector D-SUB, 1 m (S2BG12/K4SG9)

Mounting accessories

11066081	Torque arm, 1-arm, bolt circle \varnothing 82 mm, mounting M4 (mounting kit 003)
11066083	Torque arm, 1-arm, bolt circle \varnothing 74...94 mm, mounting M4/M5 (mounting kit 006)
11073119	Torque arm, 1-arm, bolt circle \varnothing 65.5...281 mm, mounting M4, can be cut to length (mounting kit 021)
11067367	Torque arm, 1-arm, bolt circle \varnothing 74...94 mm, mounting M6 (mounting kit 028)
11113210	Torque arm, 1-arm, bolt circle \varnothing 63...94 mm, mounting M4 (mounting kit 047)

Mounting accessories

11155325	Mounting plate, 1-arm, pitch circle diameter \varnothing 95 mm, mounting M6, isolated, rigid, suitable for Baumer torque arm size M6 (DMS 6) (mounting kit 099)
11129153	Torque arm, 1-arm open, bolt circle \varnothing 82...108 mm, mounting M4 (mounting kit 200)
11100198	Stator coupling, 2-armed, bolt circle \varnothing 63 mm, mounting M3 (mounting kit 046)
11106627	Fan cover clip 8 mm
11094674	Clamping ring 12/31/ 8 M3 8.8 for EIL580 hollow shaft \varnothing 8...10 mm for clamping at A or B side
11094675	Clamping ring 17/31/ 8 M3 8.8 for EIL580 hollow shaft \varnothing 12...15 mm for clamping at A side
11116921	Insulating sleeve \varnothing 10 mm/ \varnothing 12 mm/25 mm long
11116923	Insulating sleeve \varnothing 12 mm/ \varnothing 14 mm/25 mm long

Programming accessories

11120657	Handheld Programming Tool Z-PA-EI-H
11120547	PC Programming Tool Z-PA-EI-P

Incremental encoders

With blind hollow shaft

1...65536 pulses per revolution programmable (interpolated system)

ExEIL580P-B

Output signals

Zero pulse electrical 90° A&B high
(Factory setting at clockwise rotation (CW)
in view of the encoder flange)

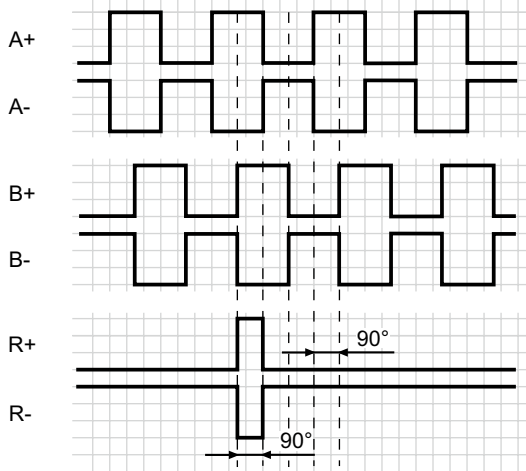

Zero pulse electrical 180° B low
(at clockwise rotation (CW)
in view of the encoder flange)

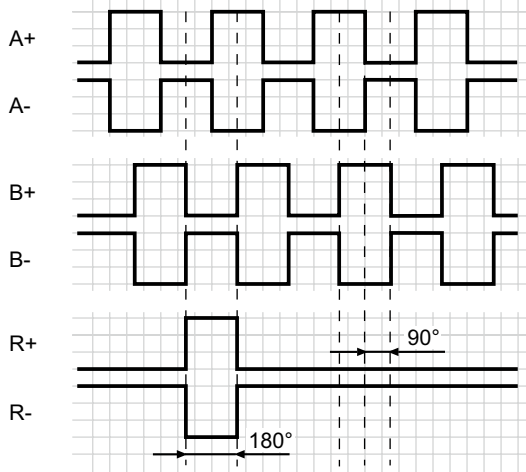

Trigger level

Outputs	TTL/RS422
Output level High	≥2.5 V
Output level Low	≤0.5 V
Load	≤20 mA

Outputs	HTL/Push-pull
Output level High	≥UB -3 V
Output level Low	≤1.5 V
Load	≤20 mA

Terminal assignment

Flange connector M23, 12-pin / cable

Pin	Core color	Assignment
1	pink	B-
2	–	–
3	blue	R+
4	red	R-
5	green	A+
6	yellow	A-
7	–	R-Set ¹⁾
8	grey	B+
9	–	–
10	white	GND
11	–	–
12	brown	UB

Screen: Connected to housing

Cable data: PUR, [4x2x0,14 mm²], bending radius >45,8 mm, outer diameter 6.1 mm

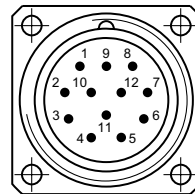

¹⁾ The R-Set input is used to set the reference pulse (zero pulse) on the current shaft position.
R-Set = UB ≥ 200 ms
(not possible via accessory connection cable)

Flange connector M12, 8-pin

Pin	Assignment
1	GND
2	UB
3	A+
4	A-
5	B+
6	B-
7	R+
8	R-

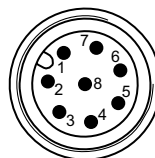

Incremental encoders

With blind hollow shaft

1...65536 pulses per revolution programmable (interpolated system)

ExEIL580P-B

Duty cycle

The duty cycle (D) is defined as the time ratio between the HIGH pulse duration (H) and the pulse period (T).

System-induced and depending on the pulse number, the measured values may vary which has an impact on speed and position acquisition.

Binary pulse numbers are recommended for speed feedback.

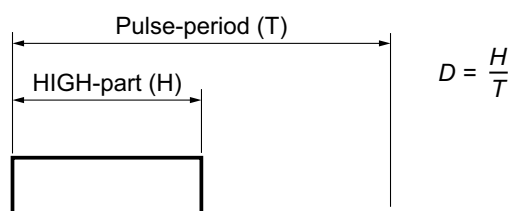

Programmed pulse number	Scan ratio (D) (maximum)	Jitter (+/-) (maximum)
1...1023	45...55 %	5%
1024, 2048	45...55 %	5%
1025...5000	40...60 %	10%
8192, 16384	35...85 %	15%
5001...10000	22...78 %	28%
32768	25...75 %	25%
65536	15...85 %	35%
all other	Jitter[%]=(programmed pulse number -10000)*0,0007%+28%	

Incremental encoders

With blind hollow shaft

1...65536 pulses per revolution programmable (interpolated system)

ExEIL580P-B

Dimensions

Clamping ring at A-side:
Blind hollow shaft, flange connector M12 radial

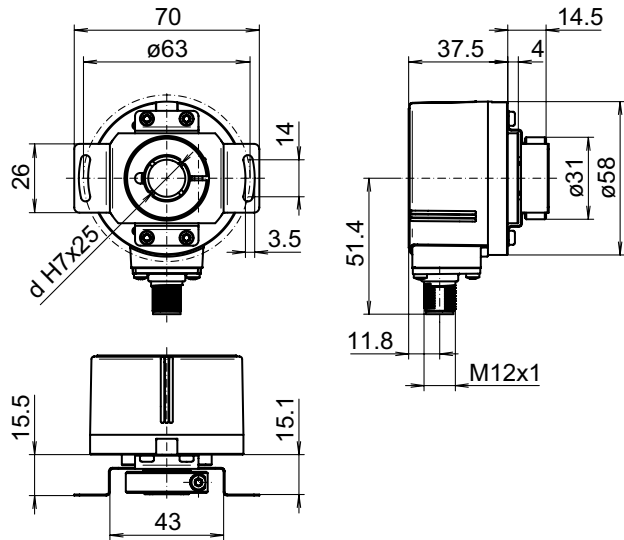

Clamping ring at A-side:
Blind hollow shaft, flange connector M12 axial

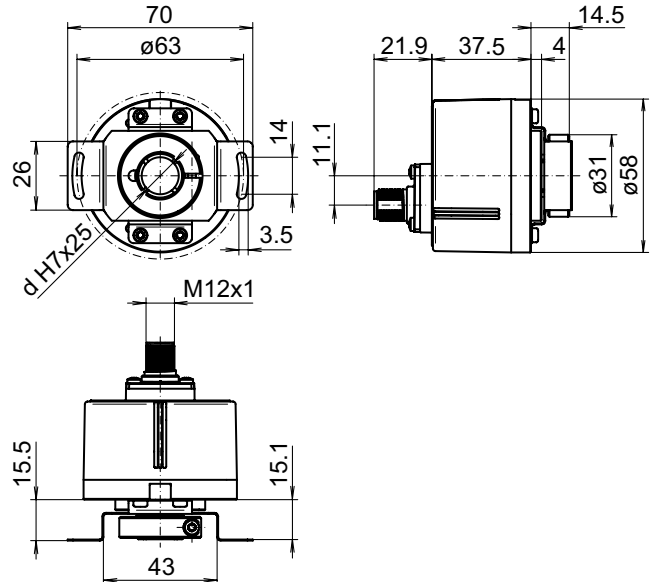

Clamping ring at A-side:
Blind hollow shaft, flange connector M23 radial

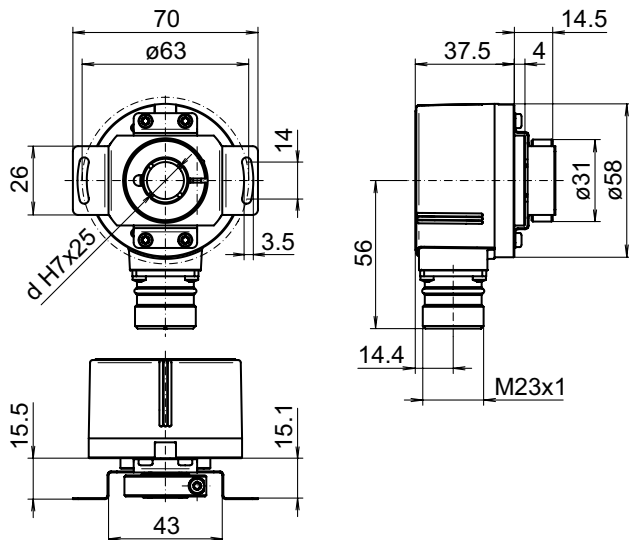

Clamping ring at A-side:
Blind hollow shaft, flange connector M23 axial

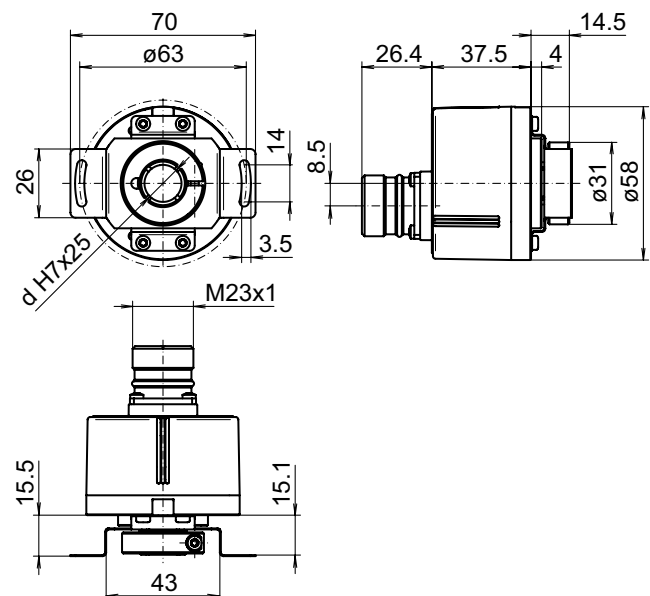

Incremental encoders

With blind hollow shaft

1...65536 pulses per revolution programmable (interpolated system)

ExEIL580P-B

Dimensions

Clamping ring at A-side:
Blind hollow shaft, cable radial

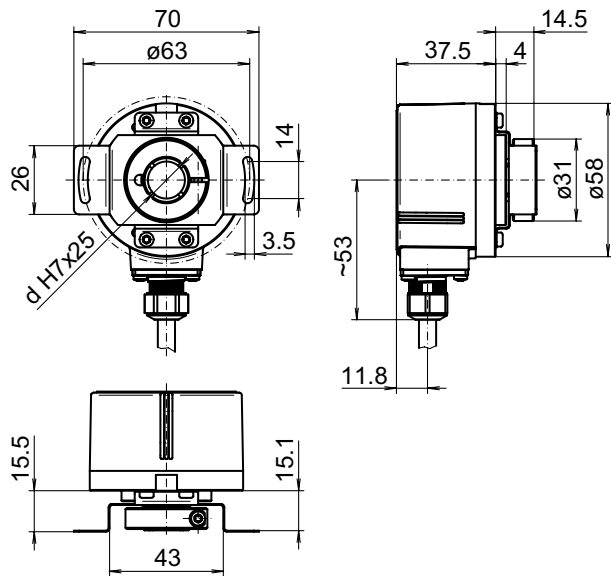

Clamping ring at A-side:
Blind hollow shaft, cable axial

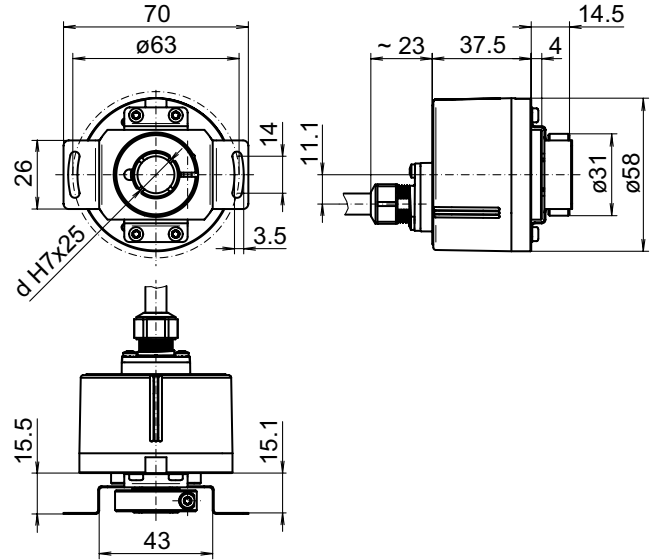

Clamping ring at A-side:
Blind hollow shaft, cable tangential

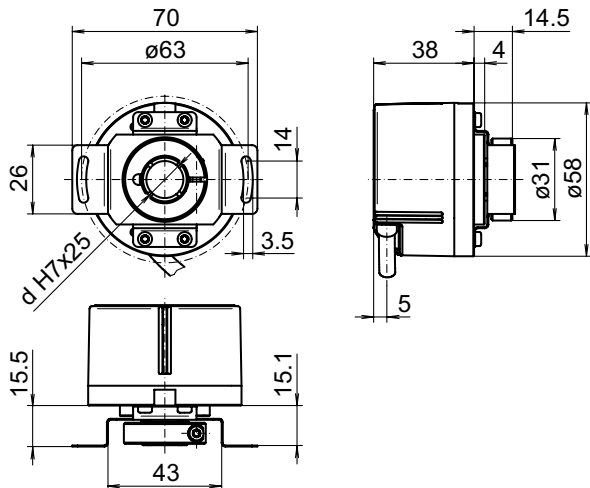

Incremental encoders

With blind hollow shaft

1...65536 pulses per revolution programmable (interpolated system)

ExEIL580P-B

Dimensions

Pin torque support, axial, clamping ring at A-side

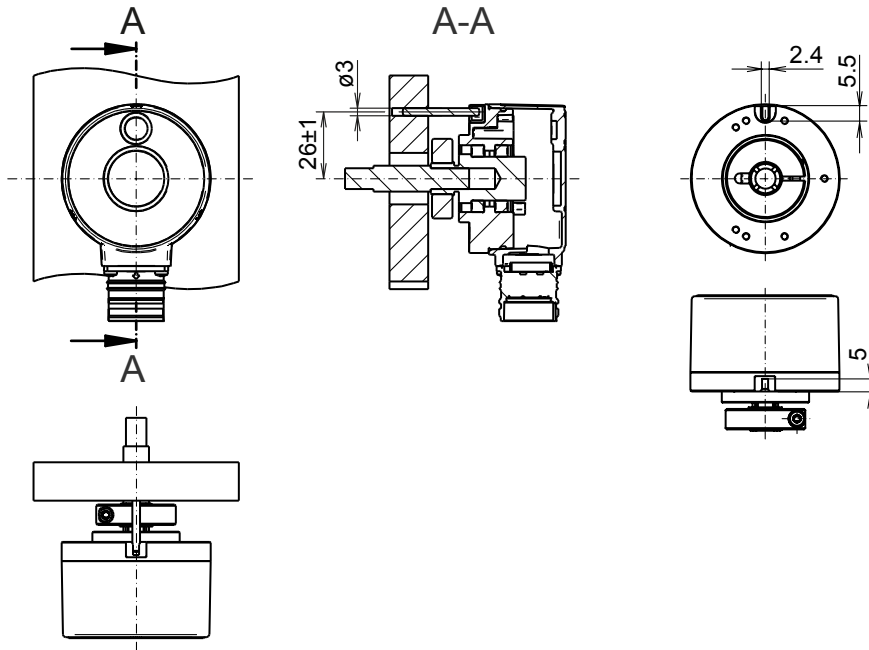

Blind hollow shaft

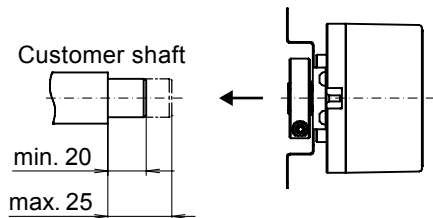

Incremental encoders

With blind hollow shaft

1...65536 pulses per revolution programmable (interpolated system)

ExEIL580P-B

Explosion protection

⊕ II 3 D Ex tc III C T135°C Dc X (dust)

General- and Special conditions „X“:

Only put the device into operation if ...

- all necessary precautions have been taken by the operator to make sure device and connector are fully protected against mechanical impacts or shocks in compliance with EN 60079-0, section 26.4.2 (Special conditions „X“).
- the connection is mechanically or electrically secured to prevent any interrupt while the contact is live (Special conditions „X“).
- it has been ensured the electrical connection of product variants with cable outlet or cable couplings is outside zone 22 (Special conditions „X“).
- it has been ensured the maximum operating speed in relation to the ambient temperature is within the specifications on the table „Maximum rotation speed below“ (Special conditions „X“).
- the specifications on the product label match the on-site conditions for use in hazardous areas (EX) (device group, category, zone, temperature class resp. maximum surface temperature).
- the specifications on the product label comply with the prevailing grid conditions.
- the device shows no visible trace of damage (resulting from transport or storage), and
- it has been ensured no explosive atmosphere, oils, acids, gases, vapors, radiation etc. are present during installation.

Observe standard EN 60079-14 for installation and commissioning.

Device operation must observe the installation and operating instructions. The intended use and application of the device comes under the relevant legislation as well as applicable directives and standards.

Maximum rotation speed

	ambient temperature	rotation speed
solid shaft	20 °C	≤ 12000 rpm
	40 °C	≤ 11000 rpm
	60 °C	≤ 8000 rpm
through hollow shaft	20 °C	≤ 6000 rpm
	40 °C	≤ 4500 rpm
	60 °C	≤ 2500 rpm
blind hollow shaft	20 °C	≤ 8000 rpm
	40 °C	≤ 8000 rpm
	60 °C	≤ 5000 rpm