

Incremental encoders

Solid shaft with clamping or synchro flange

SIL2 approval

GI357



GI357 with clamping flange

Technical data - electrical ratings

Voltage supply	24 VDC +20/-50 %
Reverse polarity protection	Yes
Consumption w/o load	≤30 mA
Pulses per revolution	5...5000
Reference signal	Zero pulse 70...720° electr. (Option)
Sensing method	Optical
Output frequency	≤150 kHz
Output signals	A 90° B + inverted
Output stages	Linedriver/RS422 Push-pull short-circuit proof
Safety operating figures	Encoder operating life: 20 years PFH: 1.16E-08 1/h SFF: >90 %
Interference immunity	DIN EN 61000-6-2 IEC 61326-3-1
Emitted interference	DIN EN 61000-6-4
Approvals	UL approval / E63076, SIL2 approval according to DIN EN 61508

Features

- Encoder with solid shaft $\varnothing 10$ mm or $\varnothing 6$ mm
- Max. 5000 pulses per revolution
- Optical sensing method
- Clamping or synchro flange
- High rotation speed up to 10000 rpm
- Compact design
- For safety-relevant applications in compliance with SIL2 (Safety Integrity Level 2)

Optional

- Additional zero pulse (not safety related)

Technical data - mechanical design

Size (flange)	$\varnothing 58$ mm
Shaft type	$\varnothing 6$ mm solid shaft (synchro flange) $\varnothing 10$ mm solid shaft (clamping flange)
Admitted shaft load	≤20 N axial ≤40 N radial
Flange	Clamping or synchro flange
Protection DIN EN 60529	IP 54 (without shaft seal), IP 65 (with shaft seal)
Operating speed	≤10000 rpm
Starting torque	≤0.015 Nm (+25 °C, IP 54) ≤0.03 Nm (+25 °C, IP 65)
Rotor moment of inertia	14.5 gcm ²
Materials	Housing: aluminium Flange: aluminium
Operating temperature	-25...+85 °C
Relative humidity	95 % non-condensing
Resistance	DIN EN 60068-2-6 Vibration 10 g, 16-2000 Hz DIN EN 60068-2-27 Shock 100 g, 6 ms
Connection	Connector M12, 8-pin Connector M23, 12-pin
Weight approx.	250 g

Incremental encoders

Solid shaft with clamping or synchro flange

SIL2 approval

GI357

Trigger level

Outputs	Linedriver RS422
Output level High	>2.5 V (I = -20 mA)
Output level Low	<0.5 V (I = 20 mA)
Load High	<20 mA
Load Low	<20 mA

Outputs	Push-pull short-circuit proof
Output level High	>UB -3 V (I = -20 mA)
Output level Low	<0.5 V (I = 20 mA)
Load High	<20 mA
Load Low	<20 mA

Output signals

Clockwise rotating direction when looking at flange.

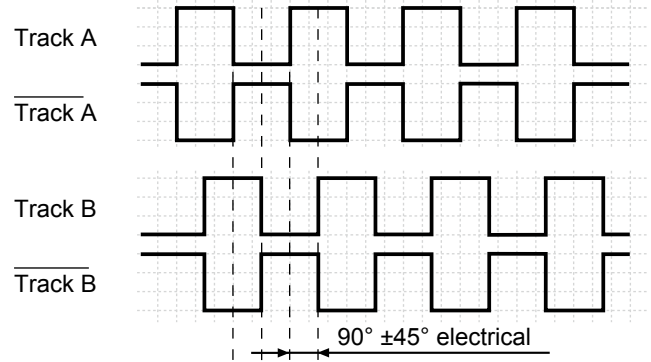

Pulse number 2500/1024/1000 - 360° mechanically

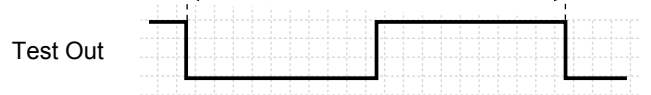

Zero pulse 70°...720° (Option)

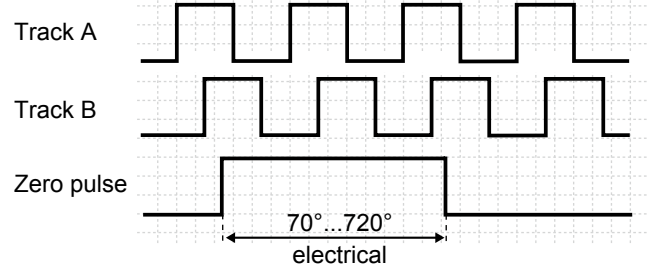

Incremental encoders

Solid shaft with clamping or synchro flange

SIL2 approval

GI357

Functional safety remarks

The safety function in the master PLC must detect the following events in order to uncover dangerous errors and, in case of error, actuate appropriate safety precautions:

Non-equivalence Monitoring

The non-inverted and inverted signal lines of each safety track (A vs. A inv. and B vs. B inv.) must have non-equivalent signal levels at all times. In state transition, very short periods of time (some microseconds) are permissible in which both lines have same logical signal level. A dangerous error occurs when this short period of time is exceeded.

Line break detection

Make sure none of the signal cables (A, A inv., B, B inv.) is high-impedant. The encoder will utilize the high-impedant status of the safety tracks (A, A inv., B, B inv.) to output an error message.

Safe rotational speed

In the event of a predefined speed limit, the master control will require identical speed frequencies on both safety tracks. If not, it is a fatal error.

Safe rotational direction

The phase shift of the safety relevant incremental signals (A vs. B and A inv. vs. B inv.) has to be monitored. A dangerous error occurs when exceeding the given tolerances. Compliance to the defined rotational direction has to be monitored as well.

Safe stop

In case of missing state changes in at least one of the signals (A, A inv., B, B inv.), the customer has to ensure shaft standstill by means of a second, independent safety precaution within an acceptable amount of time depending on the facility.

Zero pulse as well as the test output are not part of the SIL2 approval and must not be used to fulfill safety functions.

Terminal assignment

Connector M23

Connector	Assignment without zero pulse	Assignment with zero pulse
Pin 1	Track B inv.	Track B inv.
Pin 2	–	–
Pin 3	Test Out	Test Out
Pin 4	–	Zero pulse
Pin 5	Track A	Track A
Pin 6	Track A inv.	Track A inv.
Pin 7	–	–
Pin 8	Track B	Track B
Pin 9	–	–
Pin 10	GNDB	GNDB
Pin 11	–	GND Sense
Pin 12	UB	UB

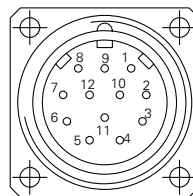

Please use cores twisted in pairs (for example track A / track A inv.) for extension cables.

Connector M12

Connector	Assignment without zero pulse
Pin 1	Track A
Pin 2	Track B
Pin 3	Track A inv.
Pin 4	Track B inv.
Pin 5	–
Pin 6	Test Out
Pin 7	GNDB
Pin 8	UB

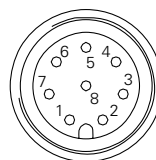

Please use cores twisted in pairs (for example track A / track A inv.) for extension cables.

Incremental encoders

Solid shaft with clamping or synchro flange

SIL2 approval

GI357

Dimensions

GI357 - clamping flange / connector M23

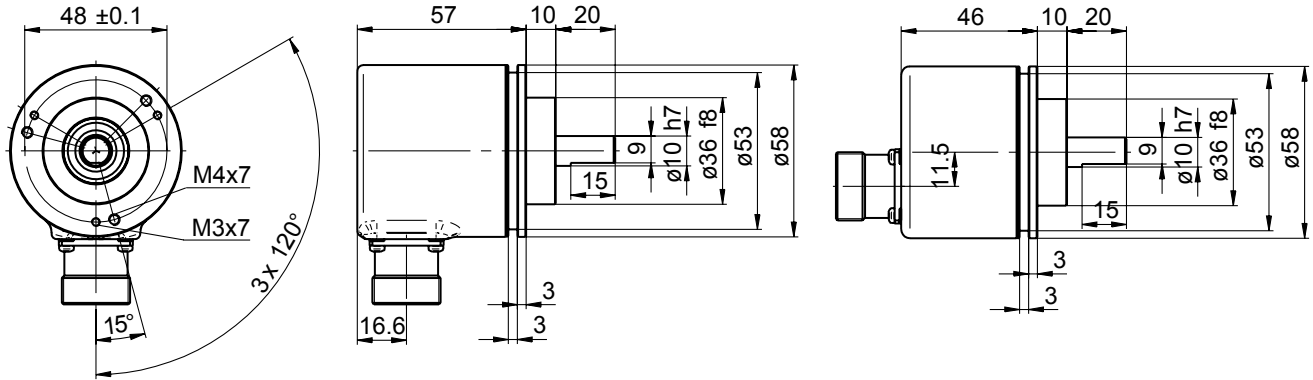

GI357 - clamping flange / connector M12

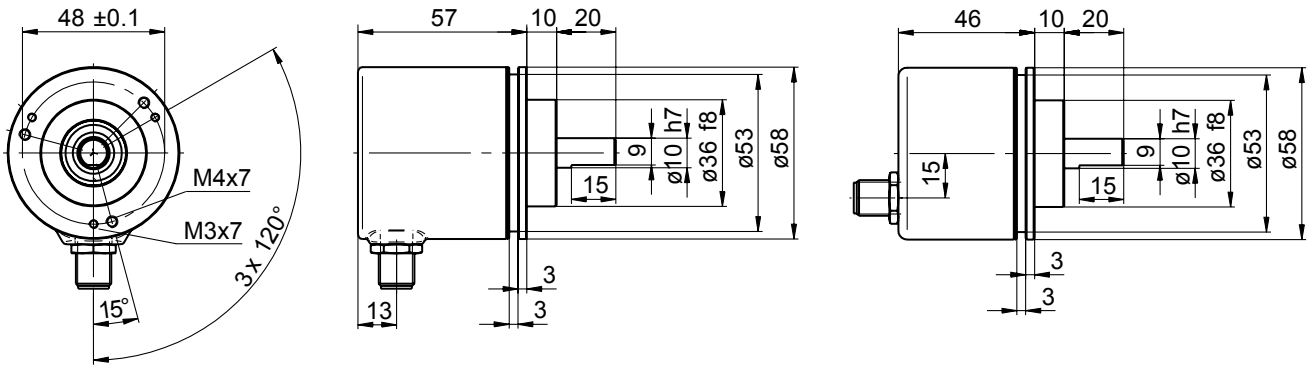

GI357 - synchro flange

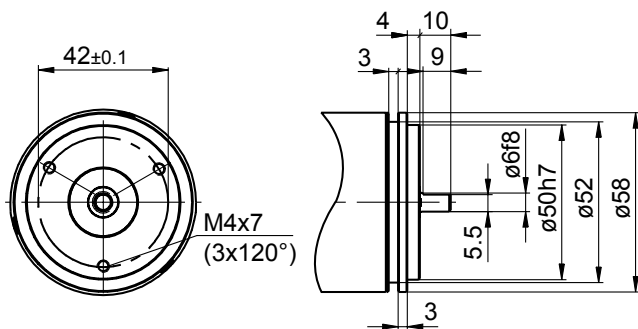

GI357 - connector dimensions

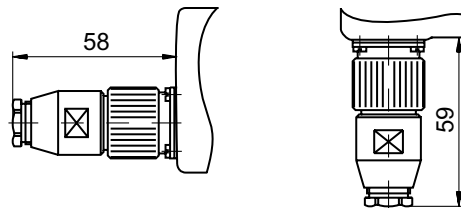

· Subject to modification in technic and design. Errors and omissions excepted.