

Absolute encoders - SSI

Blind hollow shaft or cone shaft (1:10)

ST and MT 20 bit each / Speed switch

HMG10-B - SSI

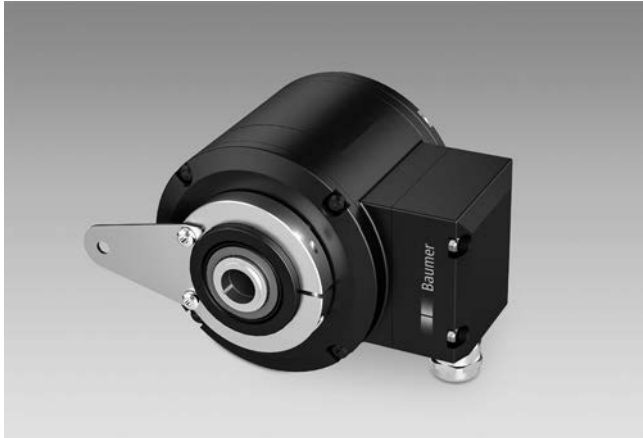

HMG10-B - picture similar

Technical data - electrical ratings

Voltage supply	4.75...30 VDC
Short-circuit proof	Yes
Consumption w/o load	≤100 mA (SSI)
Initializing time	≤500 ms after power on
Interface	SSI
Function	Multiturn
Steps per revolution	1048576 / 20 bit
Number of revolutions	1048576 / 20 bit
Additional outputs	Square-wave TTL/HTL, TTL/ RS422
Sensing method	Magnetic
Code	Gray or binary
Code sequence	CW (factory setting)
Input signals	SSI clock, PRESET, rotating direction
Interference immunity	EN 61000-6-2
Emitted interference	EN 61000-6-3
Diagnostic function	Function control
Status indicator	4 LEDs in device back side
Approvals	CE, UL approval / E256710

Technical data - electrical ratings (speed switches)

Switching accuracy	±2 % (or 1 Digit)
Switching outputs	1 output (Open collector, solid state relay on request)
Output switching capacity	30 VDC; ≤100 mA
Switching delay time	≤20 ms

Features

- Magnetic sensing method
- Function display via LEDs
- Multiturn sensing with Energy Harvesting technology, without gear or battery
- Two-sided bearing system with hybrid bearings
- Special protection against corrosion C5-M

Optional

- Integrated speed switch
- Additional outputs incremental with zero pulse

Technical data - mechanical design

Size (flange)	ø105 mm
Shaft type	ø16...20 mm (blind hollow shaft) ø17 mm (cone shaft 1:10)
Flange	Support plate, 360° freely positionable
Protection DIN EN 60529	IP 66/IP 67
Operating speed	≤12000 rpm
Range of switching speed	ns (off) = ±2...12000 rpm, factory setting 12000 rpm
Operating torque typ.	10 Ncm
Rotor moment of inertia	950 gcm ²
Admitted shaft load	≤450 N axial ≤650 N radial
Materials	Housing: aluminium alloy Shaft: stainless steel
Corrosion protection	IEC 60068-2-52 Salt mist for ambient conditions C5-M (CX) according to ISO 12944-2
Operating temperature	-40...+95 °C
Relative humidity	95 % non-condensing
Resistance	IEC 60068-2-6 Vibration 30 g, 10-2000 Hz IEC 60068-2-27 Shock 400 g, 1 ms
Weight approx.	1.6 kg (depending on version)
Connection	Terminal box Flange connector M23

Absolute encoders - SSI

Blind hollow shaft or cone shaft (1:10)

ST and MT 20 bit each / Speed switch

HMG10-B - SSI

Part number - tables

Resolution singleturn

0 (Without)	2 (12 bit)	5 (15 bit)	8 (18 bit)
A (10 bit)	3 (13 bit)	6 (16 bit)	9 (19 bit)
1 (11 bit)	4 (14 bit)	7 (17 bit)	B (20 bit)

Resolution multiturn

0 (Without)	2 (12 bit)	5 (15 bit)	8 (18 bit)
A (10 bit)	3 (13 bit)	6 (16 bit)	9 (19 bit)
1 (11 bit)	4 (14 bit)	7 (17 bit)	B (20 bit)

Resolution speed

0 (Without)	5 (15 bit, ±6000 rpm)
A (10 bit, ±6000 rpm)	6 (16 bit, ±6000 rpm)
1 (11 bit, ±6000 rpm)	7 (17 bit, ±6000 rpm)
2 (12 bit, ±6000 rpm)	8 (18 bit, ±6000 rpm)
3 (13 bit, ±6000 rpm)	9 (19 bit, ±6000 rpm)
4 (14 bit, ±6000 rpm)	B (20 bit, ±6000 rpm)

Additional output 1

0 (Without)
Q (8192 ppr TTL/HTL (Vin=Vout), 4 channels)
P (8192 ppr TTL/RS422, 4 channels)
G (5000 ppr TTL/HTL (Vin=Vout), 4 channels)
H (5000 ppr TTL/RS422, 4 channels)
K (4096 ppr TTL/HTL (Vin=Vout), 4 channels)
J (4096 ppr TTL/RS422, 4 channels)
7 (3072 ppr TTL/HTL (Vin=Vout), 4 channels)
8 (3072 ppr TTL/RS422, 4 channels)
9 (2048 ppr TTL/HTL (Vin=Vout), 4 channels)
4 (2048 ppr TTL/RS422, 4 channels)
5 (1024 ppr TTL/HTL (Vin=Vout), 4 channels)
6 (1024 ppr TTL/RS422, 4 channels)
1 (512 ppr TTL/HTL (Vin=Vout), 4 channels)
2 (512 ppr TTL/RS422, 4 channels)

Additional output 2*

0 (Without)
Q (8192 ppr TTL/HTL (Vin=Vout), 6 channels, electrically isolated)
P (8192 ppr TTL/RS422, 6 channels)
G (5000 ppr TTL/HTL (Vin=Vout), 6 channels, electrically isolated)
H (5000 ppr TTL/RS422, 6 channels)
K (4096 ppr TTL/HTL (Vin=Vout), 6 channels, electrically isolated)
J (4096 ppr TTL/RS422, 6 channels)
7 (3072 ppr TTL/HTL (Vin=Vout), 6 channels, electrically isolated)
8 (3072 ppr TTL/RS422, 6 channels)
9 (2048 ppr TTL/HTL (Vin=Vout), 6 channels, electrically isolated)
4 (2048 ppr TTL/RS422, 6 channels)
5 (1024 ppr TTL/HTL (Vin=Vout), 6 channels, electrically isolated)
6 (1024 ppr TTL/RS422, 6 channels)
1 (512 ppr TTL/HTL (Vin=Vout), 6 channels, electrically isolated)
2 (512 ppr TTL/RS422, 6 channels)

* Only for connection 2x terminal box (M) or 2x flange connector (S)

Absolute encoders - SSI

Blind hollow shaft or cone shaft (1:10)

ST and MT 20 bit each / Speed switch

HMG10-B - SSI

Terminal significance

Ub	Voltage supply
0V	Ground
A+ ²⁾	Output signal channel 1
A- ²⁾	Output signal channel 1 inverted
B+ ²⁾	Output signal channel 2 (offset by 90° to channel 1)
B- ²⁾	Output signal channel 2 inverted
R+ ²⁾	Zero pulse (reference signal)
R- ²⁾	Zero pulse inverted
nE+	System OK+ / error output
nE-	System OK- / error output inverted
PRE	PRESET/RESET
DIR	Rotating direction
SP+ ³⁾	DSL_OUT1 / speed switch (Open collector, solid state relay on request)
SP- ³⁾	DSL_OUT2 / speed switch (0V, solid state relay on request)
D+	SSI data+
D-	SSI data-
C+	SSI clock+
C-	SSI clock-
dnv	Do not use

Terminal assignment flange connectors

View C¹⁾

SSI, additional output incremental 1,

1	nE-
2	DIR
3	dnv
4	nE+
5	PRE
6	dnv
7	Ub
8	C+
9	C-
10	0V
11	Internal shield
12	dnv / B+ ²⁾
13	dnv / B- ²⁾
14	D+
15	dnv / A+ ²⁾
16	dnv / A- ²⁾
17	D-

View D¹⁾

Additional output incremental 2, speed switch

1	dnv / B- ²⁾
2	nE-
3	dnv / R+ ²⁾
4	dnv / R- ²⁾
5	dnv / A+ ²⁾
6	dnv / A- ²⁾
7	dnv / SP+ ³⁾
8	dnv / B+ ²⁾
9	dnv / SP- ³⁾
10	0V ²⁾
11	nE+
12	Ub ²⁾

Terminal assignment terminal box

View A¹⁾ - SSI, additional output incremental 1

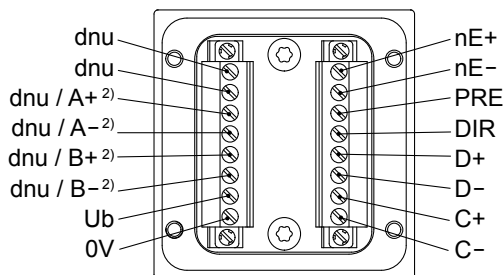

View B¹⁾ - Additional output incremental 2, speed switch

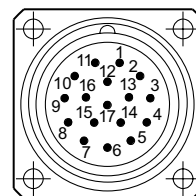
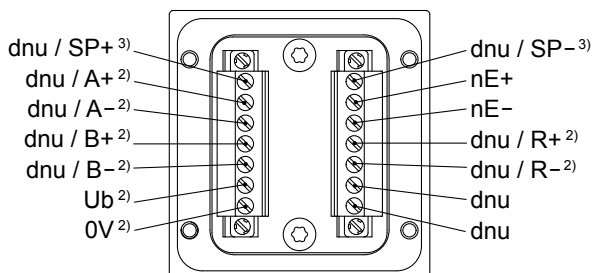

Flange connector M23
(male, 17-pin)
Clockwise (CW)

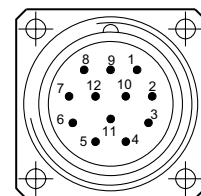

Flange connector M23
(male, 12-pin)
Clockwise (CW)

¹⁾ See dimensions

²⁾ Additional output incremental (option)

³⁾ Speed switch (option)

Absolute encoders - SSI

Blind hollow shaft or cone shaft (1:10)

ST and MT 20 bit each / Speed switch

HMG10-B - SSI

Data transfer

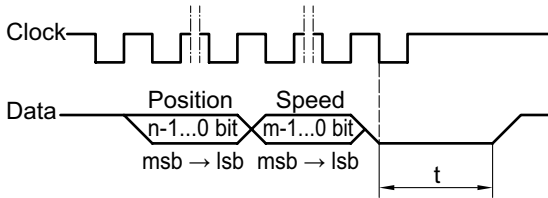

Clock frequency	100 kHz...2 MHz
Monoflop time (t)	20 μ s (internal)
n, m	Number of bits
For continuous clocking, the SSI word is transmitted only once followed by zero values (no ring register operation).	

Speed switch - Switching characteristics

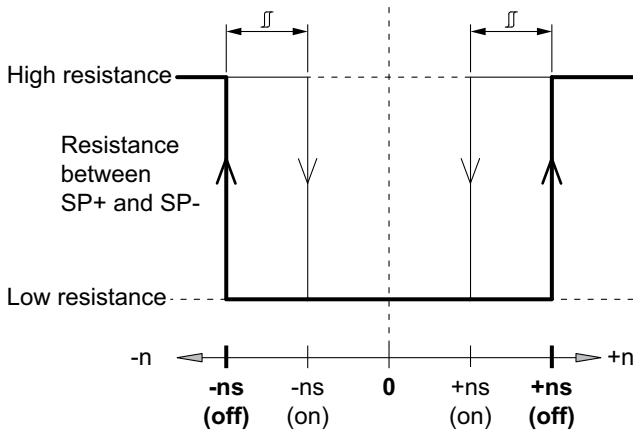

- n = Speed
- +ns (off)** = Switch-off speed at shaft rotation in positive rotating direction ¹⁾.
- ns (off)** = Switch-off speed at shaft rotation in negative rotating direction ¹⁾.
- Switching hysteresis \square :
5...100 % (factory setting = 10 % min. 1 Digit)
- +ns (on)** = Switch-on speed at shaft rotation in positive rotating direction ¹⁾.
- ns (on)** = Switch-on speed at shaft rotation in negative rotating direction ¹⁾.

Additional output incremental - Output signals

Version with additional output incremental at positive rotating direction ¹⁾

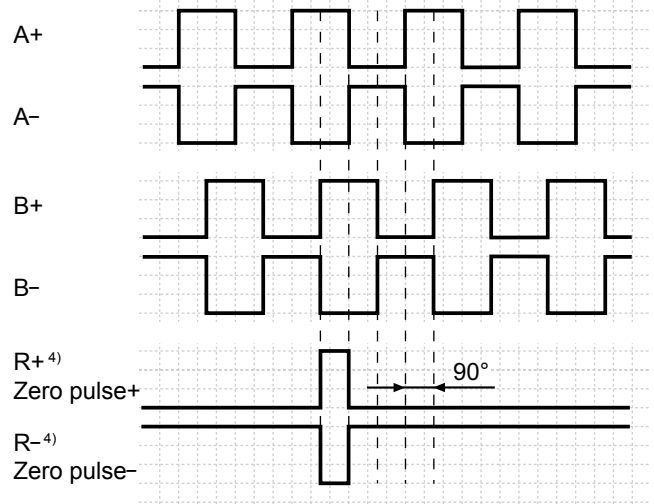

Additional output incremental - Trigger level

Trigger level	TTL/RS422
High / Low	≥ 2.5 V / ≤ 0.5 V
Transmission length	≤ 550 m @ 100 kHz
Output frequency	≤ 600 kHz
Trigger level	TTL/HTL (Vin = Vout)
High / Low	≥ 2.5 V / ≤ 0.5 V (TTL) $\geq U_b - 3$ V / ≤ 1.5 V (HTL)
Transmission length	≤ 550 m @ 100 kHz (TTL) ≤ 350 m @ 100 kHz (HTL)
Output frequency	≤ 600 kHz (TTL) ≤ 350 kHz (HTL)

Electrically isolated:
The output TTL/HTL (Vin = Vout) at the additional output incremental 2 is electrically isolated and requires a separate power supply.

¹⁾ See dimensions

⁴⁾ Only additional output incremental 2

Absolute encoders - SSI

Blind hollow shaft or cone shaft (1:10)

ST and MT 20 bit each / Speed switch

HMG10-B - SSI

Accessories

Connectors and cables

HEK 8	Sensor cable for encoders
HEK 17	Sensor cable for encoders
11068577	Mating connector M23, solder version, 12-pin, CCW
11068551	Mating connector M23, solder version, 17-pin, CCW
11172482	Mating connector M23 (11 pins assigned) 17-pin, CCW with sensor cable HEK 17, length 1 m
11172481	Mating connector M23 (11 pins assigned) 17-pin, CCW with sensor cable HEK 17, length 3 m
11172499	Mating connector M23 (11 pins assigned) 17-pin, CCW with sensor cable HEK 17, length 5 m
11172580	Mating connector M23 (11 pins assigned) 17-pin, CCW with sensor cable HEK 17, length 10 m
11172463	Mating connector M23 (17 pins assigned) 17-pin, CCW with sensor cable HEK 17, length 3 m

Mounting accessories

11043628	Torque arm M6, length 67-70 mm
11004078	Torque arm M6, length 120-130 mm (shortenable ≥ 71 mm)
11002915	Torque arm M6, length 425-460 mm (shortenable ≥ 131 mm)
11054917	Torque arm M6 insulated, length 67-70 mm
11072795	Torque arm M6 insulated, length 120-130 mm (shortenable ≥ 71 mm)
11082677	Torque arm M6 insulated, length 425-460 mm (shortenable ≥ 131 mm)
11077197	Mounting kit for torque arm size M6 and earthing strap
11077087	Mounting and dismounting set

Absolute encoders - SSI

Blind hollow shaft or cone shaft (1:10)

ST and MT 20 bit each / Speed switch

HMG10-B - SSI

Dimensions

With radial terminal boxes

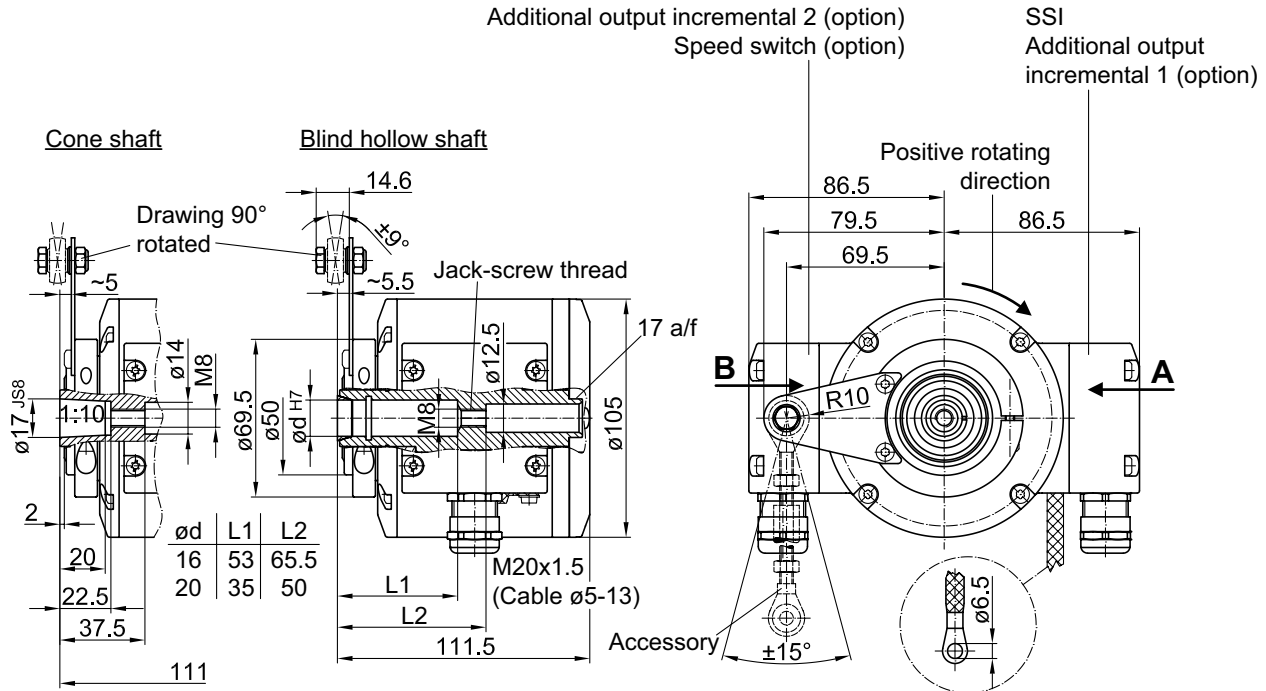

With radial flange connectors M23

