

Combination

Encoder with integrated electronic speed switch

Blind hollow shaft or cone shaft

300...5000 pulses per revolution

HOG 11 + ESL 90



HOG 11 + ESL 90

Features

- Offshore and salt water firm, high protection IP 67
- TTL output driver for cable length up to 550 m
- Electronic speed monitoring
- Circuit breaker with up to three selectable threshold speeds
- Hybrid bearing for extended service life
- Terminal boxes, turn by 180°

Optional

- Function control with EMS (Enhanced Monitoring System)
- Redundant sensing with two terminal boxes

Technical data - electrical ratings

Shaft insulation	Suitable up to 2.8 kV
Interference immunity	EN 61000-6-2
Emitted interference	EN 61000-6-3

Technical data - electrical ratings (encoder)

Voltage supply	9...30 VDC; 5 VDC \pm 5 %
Consumption w/o load	\leq 100 mA
Pulses per revolution	300...5000
Phase shift	90° \pm 20°
Duty cycle	40...60 %
Reference signal	Zero pulse, width 90°
Output frequency	\leq 120 kHz \leq 300 kHz (on request)
Output signals	K1, K2, K0 + inverted Error output (option EMS)
Output stages	HTL, TTL/RS422

Technical data - electrical ratings (speed switches)

Switching accuracy	\pm 4 % (\leq 1500 rpm) \pm 2 % ($>$ 1500 rpm)
Switching hysteresis	\approx 30 % of switching speed
Switching outputs	1 output, speed control
Output switching capacity	\leq 6 A / 250 VAC; \leq 1 A / 48 VDC
Minimum switching current	100 mA
Switching delay time	\leq 40 ms

Technical data - mechanical design

Size (flange)	\varnothing 105 mm
Shaft type	\varnothing 16...20 mm (blind hollow shaft) \varnothing 17 mm (cone shaft 1:10)
Admitted shaft load	\leq 450 N axial, \leq 600 N radial
Protection DIN EN 60529	IP 67
Operating speed	\leq 6000 rpm
Range of switching speed (ns)	650...6000 rpm
Operating torque typ.	6 Ncm
Rotor moment of inertia	680 gcm ²
Materials	Housing: aluminium die-cast Shaft: stainless steel
Operating temperature	-20...+85 °C
Resistance	IEC 60068-2-6 Vibration 5 g, 10-2000 Hz IEC 60068-2-27 Shock 50 g, 6 ms
Corrosion protection	IEC 60068-2-52 Salt mist for ambient conditions C5-M (CX) according to ISO 12944-2
Shaft insulation	2.8 kV
Transmission length	\leq 350 m at 100 kHz (HTL-P) \leq 550 m at 100 kHz (TTL)
Connection	2x terminal box 3x terminal box (with option M)
Weight approx.	2.3 kg, 2.5 kg (with option M)
Approval	CE

Combination

Encoder with integrated electronic speed switch

Blind hollow shaft or cone shaft

300...5000 pulses per revolution

HOG 11 + ESL 90

Part number

HOG11

		DN				SR		+ ESL90		...
--	--	----	--	--	--	----	--	---------	--	-----

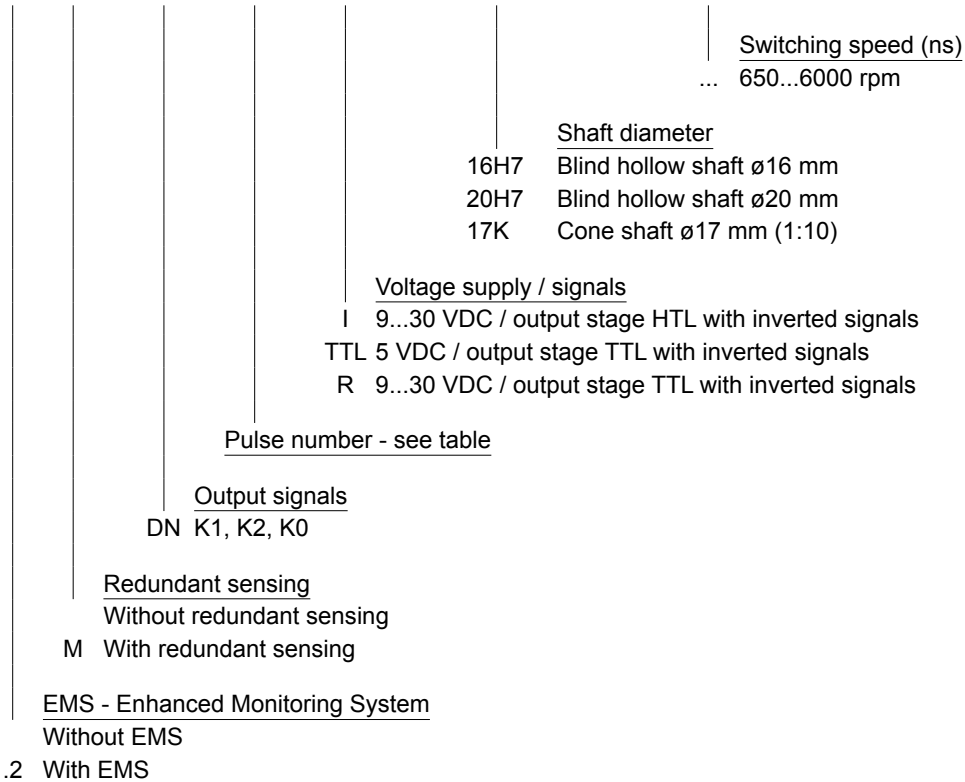

Pulse number

300	1000	2048	4096
500	1024	2500	5000
512	1200	3072	

Other pulse numbers on request.

* Please specify the exact switching speed in addition to the part number (factory setting).

Accessories

Connectors and cables

HEK 8 Sensor cable for encoders

Mounting accessories

11077197	Mounting kit for torque arm size M6 and earthing strap
11077087	Mounting and dismantling set
11043628	Torque arm M6, length 67-70 mm
11004078	Torque arm M6, length 120-130 mm (shortenable ≥71 mm)
11002915	Torque arm M6, length 425-460 mm (shortenable ≥131 mm)
11054917	Torque arm M6 insulated, length 67-70 mm
11072795	Torque arm M6 insulated, length 120-130 mm (shortenable ≥71 mm)
11082677	Torque arm M6 insulated, length 425-460 mm (shortenable ≥131 mm)

Diagnostic accessories

11075858	Analyzer for encoders HENQ 1100
11075880	Analyzer for encoders HENQ 1100 with a power pack

Combination

Encoder with integrated electronic speed switch

Blind hollow shaft or cone shaft

300...5000 pulses per revolution

HOG 11 + ESL 90

Output signals

At positive rotating direction

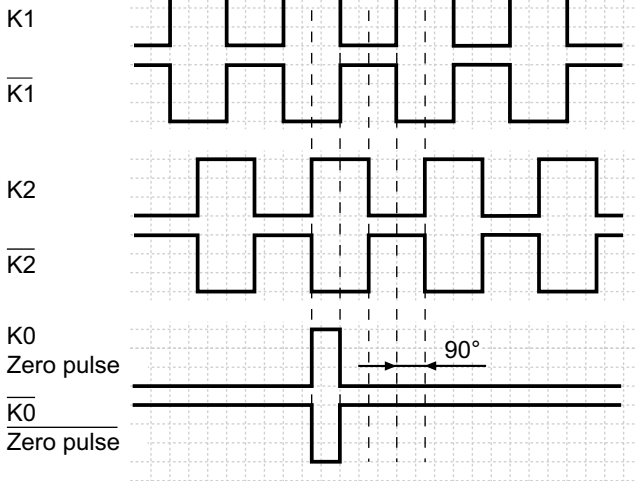

Option EMS: LED status / Error output

Flash light red*	Error of signal sequence, zero pulse or pulses (Error output = HIGH-LOW alternation)
Red	Overload output driver (Error output = LOW)
Flash light green	Device o.k., rotating (Error output = HIGH)
Green	Device o.k., stopped (Error output = HIGH)
No light	No voltage supply connection or wrong connection (Error output = LOW)

* Only at rotating device

Terminal assignment

View A

Connecting terminal terminal box HOG 11

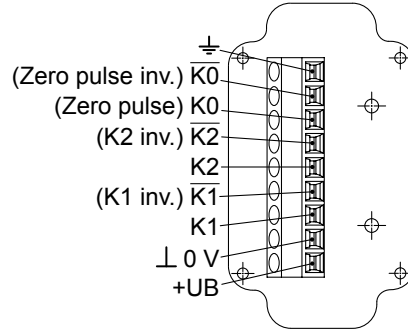

Option EMS: View A

Connecting terminal terminal box HOG 11.2

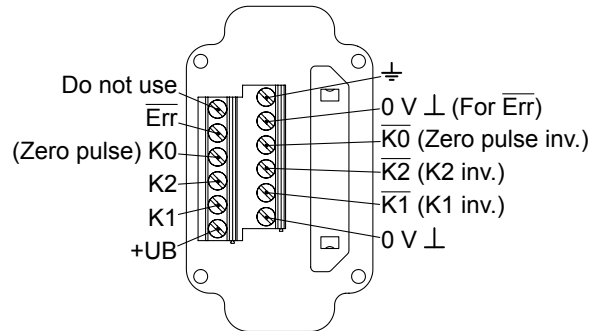

View B

Connecting terminal electronic speed switch ESL 90

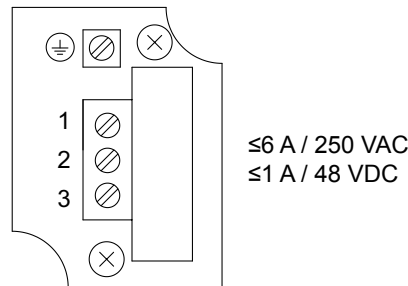

Combination

Encoder with integrated electronic speed switch

Blind hollow shaft or cone shaft

300...5000 pulses per revolution

HOG 11 + ESL 90

Block circuit diagram

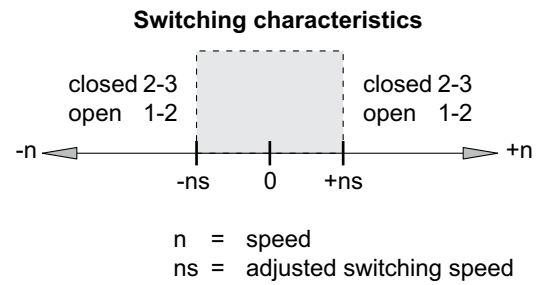
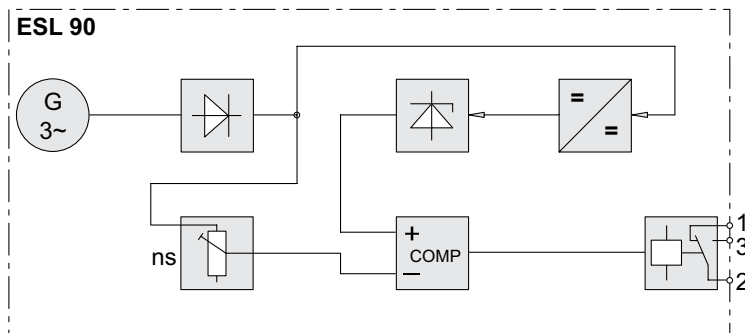

Combination

Encoder with integrated electronic speed switch

Blind hollow shaft or cone shaft

300...5000 pulses per revolution

HOG 11 + ESL 90

Dimensions

Blind hollow shaft

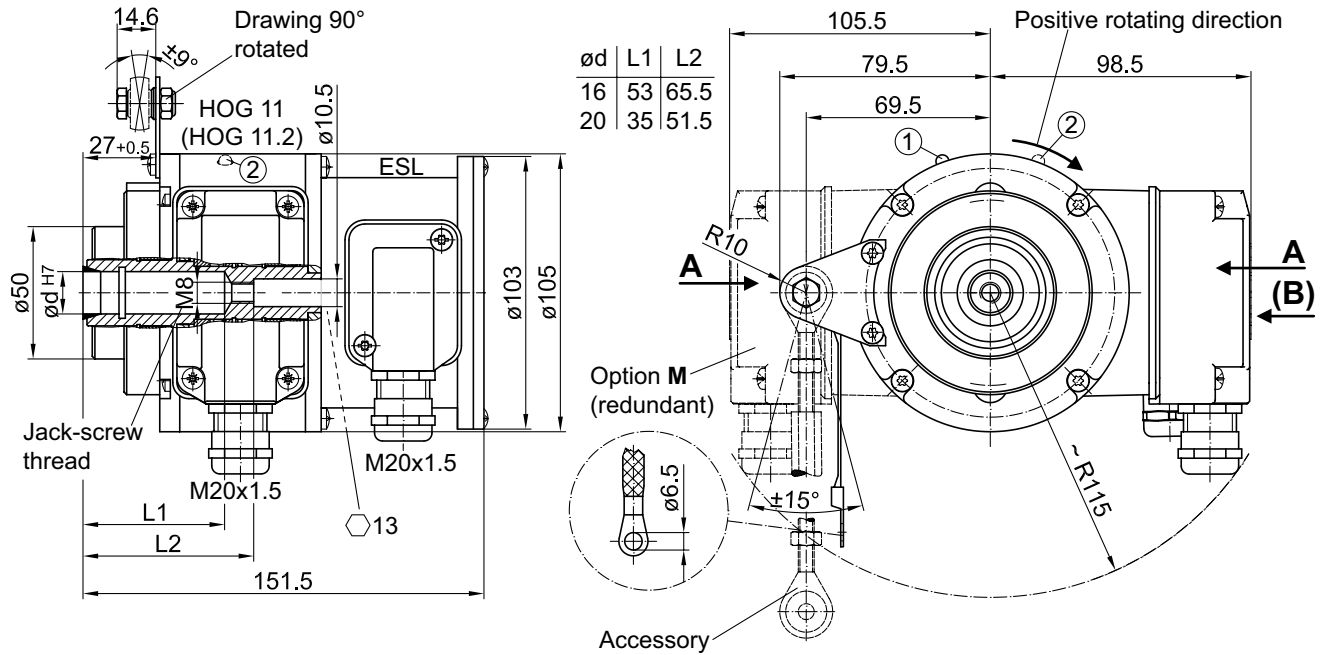

- ① Status LED (option EMS)
- ② Status LED (option **M** (redundant) and EMS)

Cone shaft

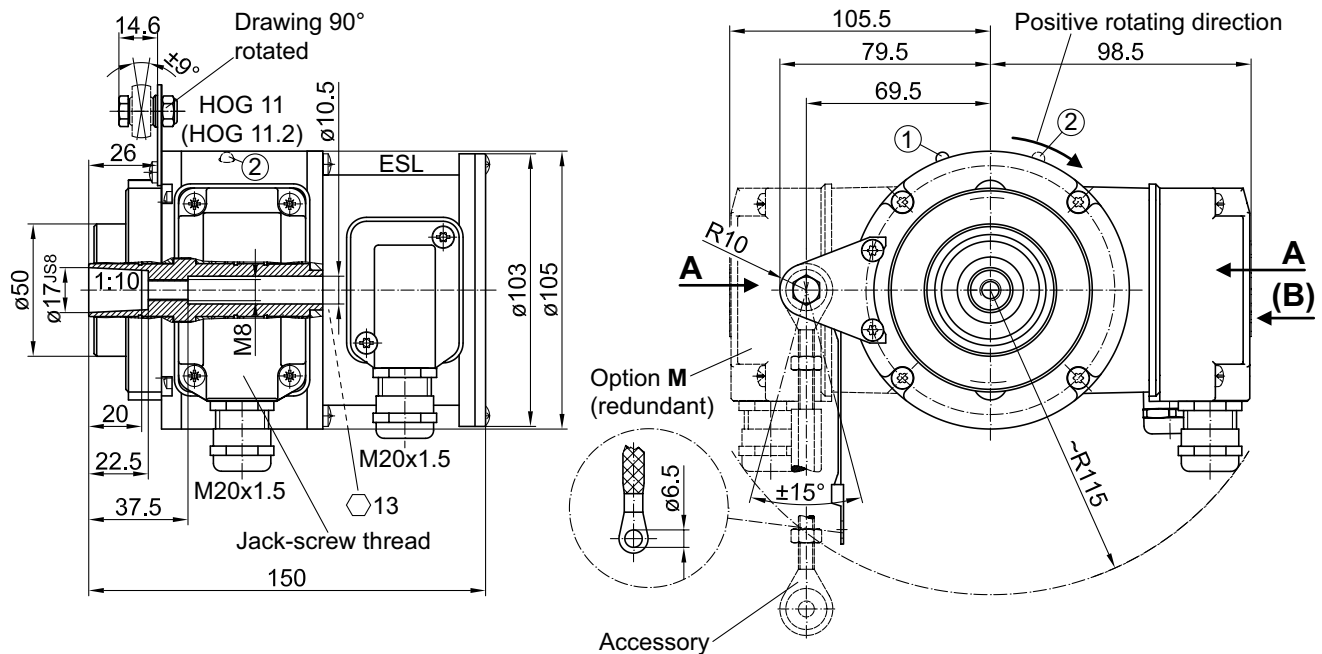

- ① Status LED (option EMS)
- ② Status LED (option **M** (redundant) and EMS)