

Incremental encoders

Blind hollow shaft $\varnothing 12$ mm

512...2048 pulses per revolution

TIL Y 1



TIL Y 1 with blind hollow shaft

Features

- Encoder with blind hollow shaft $\varnothing 12$ mm
- Max. 2048 pulses per revolution
- V-Lock clamping
- Mounting by torque support
- TTL or HTL output signals
- Tangential cable output

Optional

- Cable with connector

Technical data - electrical ratings

Voltage supply	5 VDC ± 5 % 8...26 VDC
Reverse polarity protection	Yes
Consumption w/o load	≤ 85 mA
Pulses per revolution	100...2048
Reference signal	Zero pulse, width 90°
Sensing method	Optical
Output frequency	≤ 120 kHz
Output signals	A, B, N + inverted
Output stages	TTL linedriver (short-circuit proof) HTL push-pull (short-circuit proof)
Interference immunity	DIN EN 61000-6-2
Emitted interference	DIN EN 61000-6-3

Technical data - mechanical design

Size (flange)	60 x 72 mm
Shaft type	$\varnothing 12$ mm (blind hollow shaft)
Mounting kit	042
Protection DIN EN 60529	IP 65
Operating speed	≤ 3000 rpm
Starting torque	≤ 0.01 Nm (+20 °C)
Materials	Housing: aluminium Shaft: stainless steel
Operating temperature	-20...+85 °C
Relative humidity	90 % non-condensing
Resistance	DIN EN 60068-2-6 Vibration 10 g, 55-2000 Hz DIN EN 60068-2-27 Shock 100 g, 11 ms
Connection	Cable 0.6 m
Weight approx.	320 g

Incremental encoders

Blind hollow shaft $\varnothing 12$ mm
512...2048 pulses per revolution

TIL Y 1

Part number

TIL Y 1

		NI	KT0.6	S	12	IP65	042
--	--	----	-------	---	----	------	-----

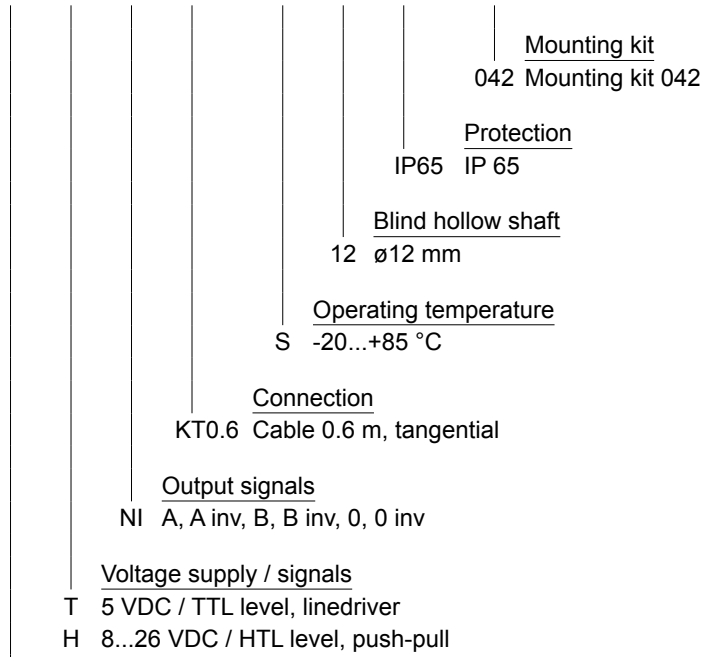

Pulse number - see table

Pulse number

512 | 1024 | 2048

Other pulse numbers on request.

Subject to modification in technic and design. Errors and omissions excepted.

Incremental encoders

Blind hollow shaft $\varnothing 12$ mm
512...2048 pulses per revolution

TIL Y 1

Output signals

Clockwise rotation when looking at the mounting side.

NI-Output signals

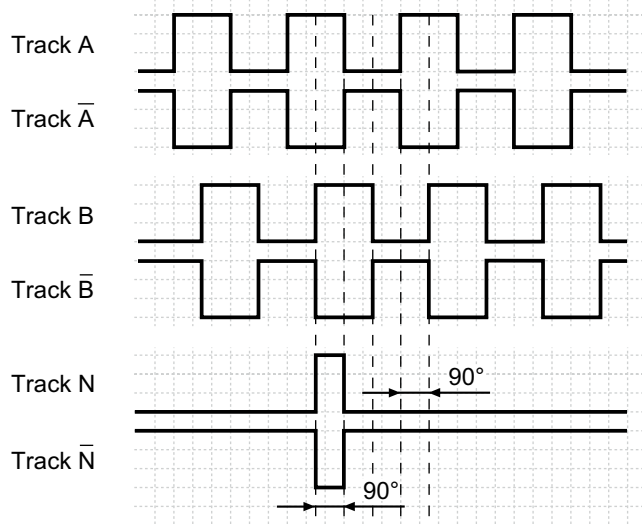

Terminal assignment

Core colour	Assignment
green	Track A
brown	Track A inv.
grey	Track B
black	Track B inv.
pink	Track N
white	Track N inv.
red	UB
blue	GND
transparent	Shield/Housing

Trigger level

Outputs	Linedriver
Output level High	≥ 2.4 V
Output level Low	≤ 0.5 V
Load	≤ 20 mA

Outputs	Push-pull short-circuit proof
Output level High	$\geq UB - 3$ V
Output level Low	≤ 1.5 V
Load	≤ 20 mA

Incremental encoders

Blind hollow shaft $\varnothing 12$ mm
512...2048 pulses per revolution

TIL Y 1

Dimensions

perspectives
on a scale of 1:2

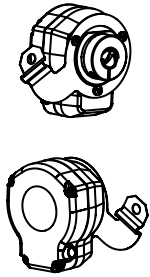

mounting
kit 042
(standard)

shaft v-lock

cylinder head screw
DIN 912 - M4
A/F3
tightening torque
max. 2.2 Nm

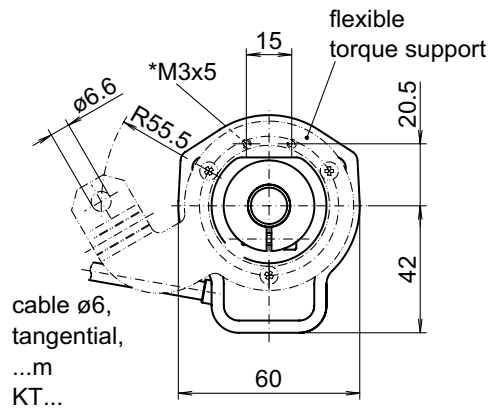
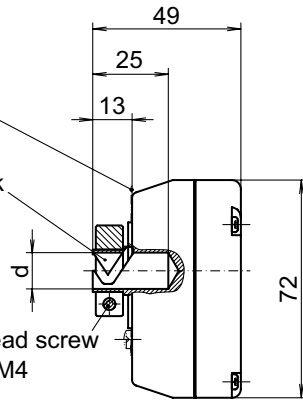

036- 2 Y 1