

# Incremental encoders

Ex approval Ex II 2D/2G (ATEX)

5...5000 pulses per revolution

## X 700 - incremental



X 700 with EX-proof housing

### Features

- Encoder incremental / ATEX
- Optical sensing method
- Max. 5000 pulses per revolution
- Clamping flange with solid shaft  $\varnothing 10$  mm
- Explosion protection per Ex II 2D/2G (ATEX)
- Device class 2 / zone 1 (gas), zone 21 (dust)
- Material stainless steel

### Technical data - electrical ratings

Voltage supply	4.75...30 VDC
Reverse polarity protection	Yes
Consumption w/o load	$\leq 50$ mA
Pulses per revolution	5...5000
Reference signal	Zero pulse, width $90^\circ$
Sensing method	Optical
Output frequency	$\leq 300$ kHz
Output signals	A $90^\circ$ B, N + inverted
Output stages	Push-pull short-circuit proof
Interference immunity	DIN EN 61000-6-2
Emitted interference	DIN EN 61000-6-4

### Technical data - mechanical design

Size (flange)	$\varnothing 70$ mm
Shaft type	$\varnothing 10$ mm solid shaft (clamping flange)
Admitted shaft load	$\leq 60$ N axial $\leq 50$ N radial
Flange	Clamping flange
Protection DIN EN 60529	IP 67
Operating speed	$\leq 6000$ rpm
Starting torque	$\leq 0.04$ Nm (+25 °C)
Materials	Housing: stainless steel Flange: stainless steel
Operating temperature	-20...+70 °C
Relative humidity	95 % non-condensing
Resistance	DIN EN 60068-2-27 Shock 300 g, 1 ms DIN EN 60068-2-27 Shock 100 g, 6 ms
Explosion protection	Ex II 2G Ex d IIC T4/T6 Ex II 2D
Connection	Cable 2 m (other length upon request)
Weight approx.	1300 g

### Output signals

Clockwise rotating direction when looking at flange.

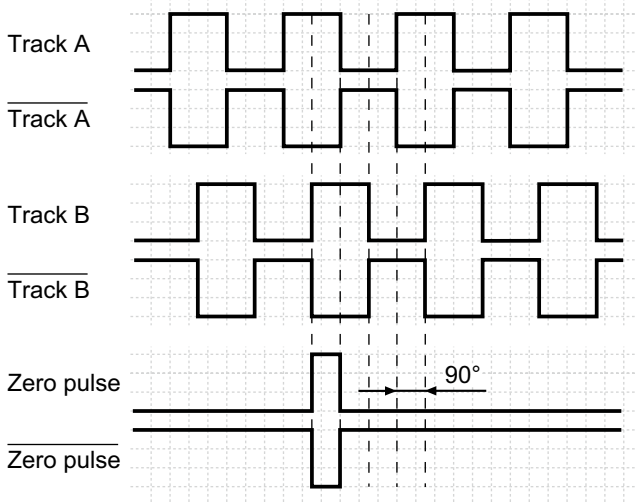

Optional: other reference impulse.

# Incremental encoders

Ex approval Ex II 2D/2G (ATEX)  
5...5000 pulses per revolution

## X 700 - incremental

### Part number

X 700.I 1

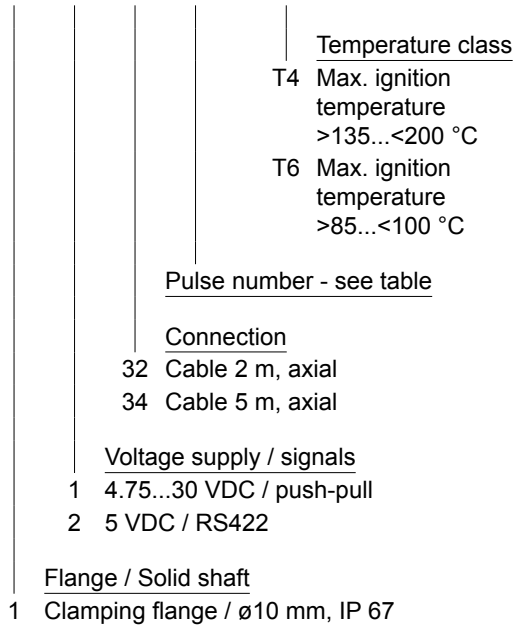

### Terminal assignment

Core no.	Core colour	Assignment
#1	white	GND
#2	brown	UB
#3	green	Track A
#4	yellow	Track B
#5	grey	Track N
#6	pink	Track A inv.
#7	blue	Track B inv.
#8	red	Track N inv.

### Trigger level

Outputs	Push-pull short-circuit proof
Output level High	>UB -1.4 V (I = -20 mA)
Output level Low	<0.5 V (I = 20 mA)
Load High / Low	<20 mA

### Pulse number

Part number (pulse number)

49 (5)	41 (100)	14 (400)	28 (2000)
36 (10)	57 (128)	15 (500)	34 (4096)
50 (25)	06 (200)	22 (1000)	
39 (50)	09 (250)	23 (1024)	
40 (60)	13 (360)	26 (1500)	

Other pulse numbers on request.

Example: part number 23 = 1024 pulses.

### Dimensions

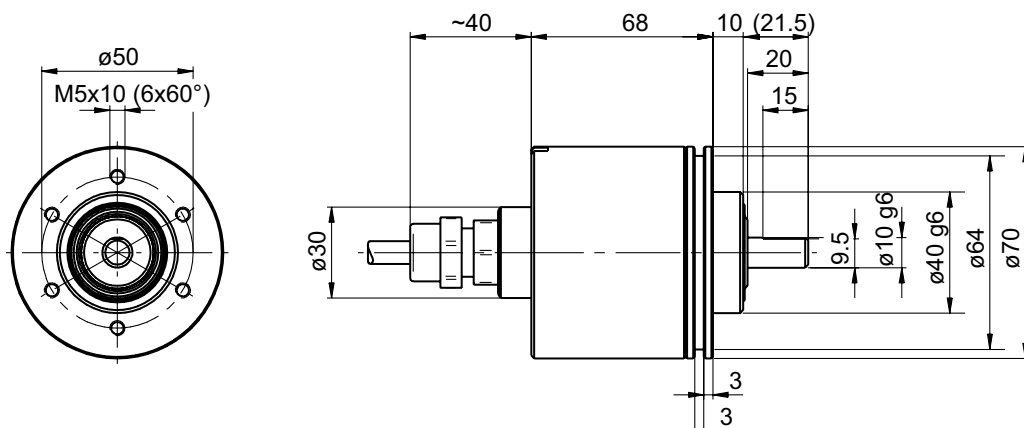

# Incremental encoders

Ex approval Ex II 2D/2G (ATEX)

5...5000 pulses per revolution

## X 700 - incremental

---

### Checklist for EX protection data collection

For the design of explosion-proof encoders of the X 700 series according to EU Directive 2014/34/EU, it is absolutely necessary to complete this checklist in order to be able to resolve all open questions regarding explosion protection and application conscientiously.

Company: \_\_\_\_\_

Address: \_\_\_\_\_

Department: \_\_\_\_\_ Phone-No.: \_\_\_\_\_

Clerk/Technician: \_\_\_\_\_

Email: \_\_\_\_\_ Fax: \_\_\_\_\_

#### Responsibility:

The operator is responsible for maintaining the performance limit of the devices (see datasheet)

Equipment group:	Please select
Equipment group I, M2 Mining (underground /above-ground mining)	
Equipment group II, 2G/2D all other areas	

**Equipment Use / Field Application:** (i.e.: paint line, process engineering, gas storage etc.)

\_\_\_\_\_

\_\_\_\_\_

Information on operating temperature and ambient temperature	Enter values
Expected operating temperature:	
Operating temperature: _____ Standard: -20...+70 °C, optional 100 °C	datasheet
Ambient temperature in the field:	

Mechanical load	Enter values
Numbers of Revolutions: _____ RMP max. 3000 RMP	
Axial shaft load: _____ (N)	
Radial shaft load: _____ (N)	
Environmental influences (Salt, alkalis, etc.): _____	

<b>Date:</b> _____	<b>Stamp:</b> _____
<b>Signature:</b> _____	