

# Accessories

## Connectors and cables

### Adapter cable for programming the HMG10P/PMG10P bus interfaces series



#### Description

Adapter cable with D-SUB connector (male) for connection of encoders of HMG10/PMG10 bus interfaces series to the WLAN adapter Z-PA.SDL.1. The encoder can be connected to the WLAN adapter in ONLINE or OFFLINE mode.

#### Part number

11191145 Adapter cable for programming the HMG10P/PMG10P bus interfaces series  
D-SUB connector (male) 15-pin with connecting cable, D-SUB connector (male) 9-pin and 7-pin connecting terminal

#### Scope of delivery

D-SUB connector (male) 15-pin with connecting cable, D-SUB connector (male) 9-pin and 7-pin connecting terminal

#### Suitable for

Z-PA.SDL.1 WLAN adapter, HMG10P/PMG10P

#### Assembly drawing

##### OFFLINE(OFFLINE) mode

Connecting terminal for terminal box for HMG10P/PMG10P bus interfaces series

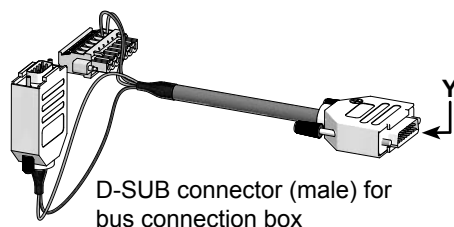

For the ONLINE mode the connecting terminal can be removed and the cable ends SA and SB can be connected directly to the connecting terminals of the encoder or connected to the existing cable ends (customer installation) in the machine/plant control cabinet. The voltage supply of the encoder is provided by the machine/plant control. In OFFLINE mode the encoder is supplied via the D-SUB connector (female) in the bus connection box.

#### Terminal assignment

##### Connecting terminal for terminal box and D-SUB connector (male) for bus connection box for HMG10P/PMG10P bus interfaces series

D-SUB connector (male) for bus connection box      Connecting terminal for terminal box

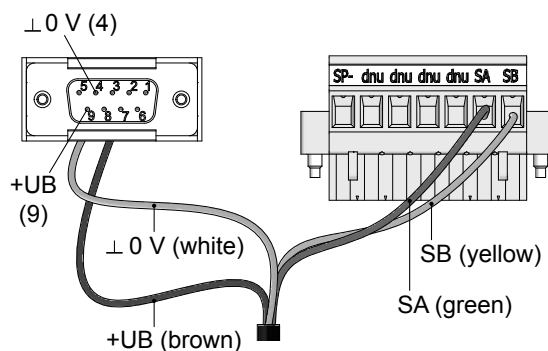

##### View Y D-SUB connector (male) for connection to the WLAN adapter

