

**Hall sensors**

**MHRM 18P5524**

**dimension drawing**

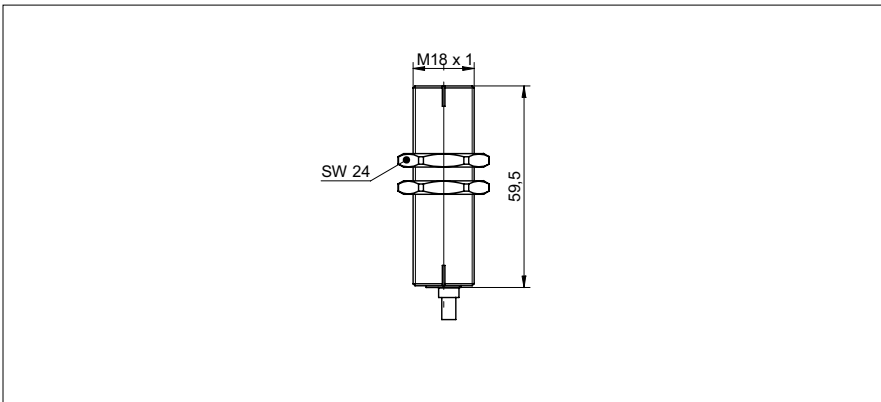

**general data**

version	full metal
sensor type	differential hall sensor
working distance max.	0,7 mm (module 1), 1,8 mm (module 2)
min. gear size	> module 1
gear width	> 6 mm
gear material	ferromagnetic

**electrical data**

switching frequency range	1 ... 20 kHz
voltage supply range +Vs	8 ... 28 VDC
current consumption max. (no load)	20 mA
output A	PNP
output B	none
output current	< 40 mA
voltage drop Vd	< 2 VDC
short circuit protection	yes
reverse polarity protection	yes, Vs to GND

**mechanical data**

type	cylindrical threaded
housing material	stainless steel
dimension	18 mm
housing length	60 mm
connection types	cable FEP, 2 m
front of sensor durable against pressure	20 bar

**ambient conditions**

operating temperature	-40 ... +120 °C
protection class (sensing face)	IP 68
protection class (sensor)	IP 67

**photo**



**connection diagram**

