

Ultrasonic distance measuring sensors

UR18.DA0.2-11200640

dimension drawing

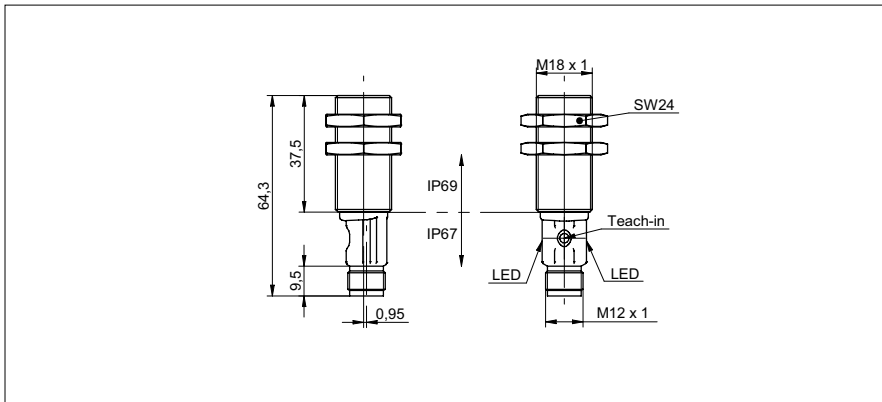

general data

scanning range Sd	70 ... 1000 mm
scanning range close limit Sdc	70 ... 1000 mm
scanning range far limit Sde	70 ... 1000 mm
version	IO-Link dual channel
hysteresis typ.	4 % Sde
repeat accuracy	< 0,5 mm
resolution	< 0,3 mm
response time ton	< 40 ms
release time toff	< 40 ms
temperature drift	< 2 % of distance to target So
power-up drift	compensated after 15 min.
sonic frequency	200 kHz
adjustment	qTeach, line-Teach, IO-Link
light indicator	LED yellow
power on indication	LED green
alignment measuring axis	< 2°

electrical data

voltage supply range +Vs	12 ... 30 VDC
current consumption typ.	35 mA
output circuit	current output
output signal	4 ... 20 mA / 20 ... 4 mA
output current	< 100 mA
voltage drop Vd	< 3,5 VDC
residual ripple	< 10 % Vs
short circuit protection	yes
reverse polarity protection	yes, Vs to GND

mechanical data

type	cylindrical threaded
housing material	stainless steel (V2A) /TR90
coating active face	PEEK
width / diameter	18 mm
height / length	64 mm
connection types	connector M12 5 pin

photo



connection diagram

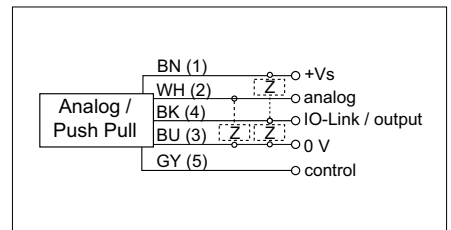

Ultrasonic distance measuring sensors

UR18.DA0.2-11200640

ambient conditions

operating temperature	-25 ... +65 °C
storage temperature	-40 ... +75 °C
protection class	IP 69
protection class (connection)	IP 67

communications interface

interface	IO-Link V1.1
baud rate	38,4 kBaud (COM 2)
cycle time	≥ 12 ms
process data length	32 Bit
process data structure	Bit 0 = SSC1 (distance) Bit 1 = SSC2 (distance) Bit 2 = quality Bit 3 = alarm Bit 5 = SSC4 (counter) Bit 8-15 = scale factor Bit 16-47 = 32 Bit measurement

IO-Link port type Class A

additional data
 distance
 excess gain
 operating cycles
 operating hours
 boot cycles
 operating voltage
 device temperature
 histograms

adjustable parameters
 switching point
 switching hysteresis
 measured value filtering
 time filters
 LED status indicators
 output logic
 output circuit
 counter
 beam forming
 analog output characteristic
 function of pin 5
 deactivate the sensor element
 Find Me function

typical sonic cone profile

