



Installation and Operating instructions for **C9900-U332-0010 battery pack**

Version: 1.3
Date: 2017-03-23

BECKHOFF

Table of contents

1	Foreword	3
1.1	Notes on the Documentation	3
1.1.1	Liability Conditions	3
1.1.2	Trademarks	3
1.1.3	Patent Pending	3
1.1.4	Copyright	3
1.1.5	State at Delivery	3
1.1.6	Delivery conditions	3
1.2	Description of safety symbols	4
1.3	Basic safety measures	5
1.4	Operator's obligation to exercise diligence	5
1.4.1	National regulations	5
2	Product Description	6
3	Installation	7
3.1	Transport and Unpacking	7
3.1.1	Transport	7
3.1.2	Unpacking	7
3.2	Mounting	8
3.2.1	Vertical Installation	8
3.2.2	Horizontal Installation	9
3.2.3	Modification of the mounting plate	9
3.3	Connecting the Battery Pack	11
3.3.1	Pin assignment of the Connector	11
4	Operating Instructions	12
4.1	Appropriate Use	12
4.2	Operation	12
4.3	Servicing and maintenance	12
4.3.1	Cleaning	12
4.3.2	Maintenance	12
4.4	Emergency procedures	12
4.5	Shutting down	12
4.5.1	Disposal	12
5	Assembly dimensions	13
6	Wiring diagram	14
7	Technical Data	15

8	Appendix	16
8.1	Beckhoff Support and Service	16
8.1.1	Beckhoff branches and partner companies	16
8.1.2	Beckhoff company headquarters	16
8.2	Approvals for USA and Canada	17
8.3	FCC Approvals for the United States of America	17
8.4	FCC Approval for Canada	17

1 Foreword

1.1 Notes on the Documentation

This description is only intended for the use of trained specialists in control and automation engineering who are familiar with the applicable national standards. It is essential that the following notes and explanations are followed when installing and commissioning these components.

The responsible staff must ensure that the application or use of the products described satisfy all the requirements for safety, including all the relevant laws, regulations, guidelines and standards.

1.1.1 Liability Conditions

The documentation has been prepared with care. The products described are, however, constantly under development. For that reason the documentation is not in every case checked for consistency with performance data, standards or other characteristics. In the event that it contains technical or editorial errors, we retain the right to make alterations at any time and without warning. No claims for the modification of products that have already been supplied may be made on the basis of the data, diagrams and descriptions in this documentation.

1.1.2 Trademarks

Beckhoff[®], TwinCAT[®], EtherCAT[®], Safety over EtherCAT[®], TwinSAFE[®] and XFC[®] are registered trademarks of and licensed by Beckhoff Automation GmbH.

Other designations used in this publication may be trademarks whose use by third parties for their own purposes could violate the rights of the owners.

1.1.3 Patent Pending

The EtherCAT Technology is covered, including but not limited to the following patent applications and patents: EP1590927, EP1789857, DE102004044764, DE102007017835 with corresponding applications or registrations in various other countries.

The TwinCAT Technology is covered, including but not limited to the following patent applications and patents: EP0851348, US6167425 with corresponding applications or registrations in various other countries.

1.1.4 Copyright

© Beckhoff Automation GmbH & Co. KG.

The reproduction, distribution and utilization of this document as well as the communication of its contents to others without express authorization are prohibited. Offenders will be held liable for the payment of damages. All rights reserved in the event of the grant of a patent, utility model or design.

1.1.5 State at Delivery





All the components are supplied in particular hardware and software configurations appropriate for the application. Modifications to hardware or software configurations other than those described in the documentation are not permitted, and nullify the liability of Beckhoff Automation GmbH & Co. KG.

1.1.6 Delivery conditions





In addition, the general delivery conditions of the company Beckhoff Automation GmbH & Co. KG apply.

1.2 Description of safety symbols

The following safety symbols are used in this operating manual. They are intended to alert the reader to the associated safety instructions.

 DANGER	<p>Acute risk of injury!</p> <p>If you do not adhere the safety advise adjoining this symbol, there is immediate danger to life and health of individuals!</p>
 WARNING	<p>Risk of injury!</p> <p>If you do not adhere the safety advise adjoining this symbol, there is danger to life and health of individuals!</p>
 CAUTION	<p>Hazard to individuals!</p> <p>If you do not adhere the safety advise adjoining this symbol, there is obvious hazard to individuals!</p>
 Attention	<p>Hazard to devices and environment</p> <p>If you do not adhere the notice adjoining this symbol, there is obvious hazard to materials and environment.</p>
 Note	<p>Note or pointer</p> <p>This symbol indicates information that contributes to better understanding.</p>

1.3 Basic safety measures

 <p>Note</p>	<p>Appropriate Use</p> <p>The battery pack C9900-U332-0010 is designed for use with the following devices with Intel® Atom™ processor: CP62xx-xxxx-0020 und C6915.</p>
 <p>DANGER</p>	<p>Switch off the power supply of the Industrial PC during installation</p> <p>During installation and removal of the battery pack, the power supply of the Industrial PC must be switched off.</p>
 <p>Attention</p>	<p>Only appropriately trained staff may install the battery pack</p> <p>The operator must ensure that only appropriately trained electricians deal with installation and wiring of the battery pack.</p>
 <p>Attention</p>	<p>Ventilation of the battery pack location</p> <p>When storing, installing and operating the battery pack, the regulations of VDE 0510 Part 2 / EN 50272-2 or the applicable national regulations must be complied with.</p> <p>It must be ensured that the battery pack location is suitably ventilated.</p>

1.4 Operator's obligation to exercise diligence

The operator must ensure that

- the product is only used as intended (see chapter [Product Description](#))
- the product is in a sound condition and in working order during operation
- the product is operated, maintained and repaired only by suitably qualified and authorized personnel
- the personnel is instructed regularly about relevant occupational safety and environmental protection aspects, and is familiar with the operating manual and in particular the safety notes contained herein
- the operation manual is in good condition and complete, and always available for reference at the location of the product.

 <p>Note</p>	<p>Do not open the housing of the battery pack!</p> <p>For technical support contact Beckhoff Service.</p>
--	---

1.4.1 National regulations

Depending on the type of machine and plant in which the Industrial PC is used, national regulations governing the controllers of such machines will apply, and must be observed by the operator. These regulations cover, amongst other things, the intervals between inspections of the controller. The operator must initiate such inspections in good time.

2 Product Description

Front view of C9900-U332-0010



Industrial PCs can be equipped with a 24 V power supply unit and an integrated UPS. The UPS supplies the PC with power if the mains power fails. This allows data to be saved on the hard disk or Flash, after which the PC can be shut down properly.

A battery pack, which serves as the energy storage device, is mounted on a DIN rail outside the PC. With its rated capacity of 1.3 Ah, the very compact C9900-U332-0010 24 V battery pack is designed for PCs with Intel® Atom™ processor.

The battery pack offers the following benefits:

- battery pack for PCs with 24 V power supply with integrated UPS
- metal housing for mounting on norm rail TS35 x 15
- optional vertical or horizontal mounting
- two 12 V batteries in series connection
- VRLA AGM Technology = valve regulated lead acid batteries with glass fiber mat inside the separator (VRLA = valve regulated lead acid, AGM = absorbed glass mat technology).

3 Installation

3.1 Transport and Unpacking

The specified storage conditions must be observed (see chapter [Technical Data](#)).

3.1.1 Transport

Despite the robust design of the unit, the components are sensitive to strong vibrations and impacts. During transport, your device should therefore be protected from excessive mechanical stress. Therefore, please use the original packaging.

 Attention	Danger of damage to the unit If the device is transported in cold weather or is exposed to extreme variations in temperature, make sure that moisture (condensation) does not form on or inside the device.
---	---

Prior to operation, the unit must be allowed to slowly adjust to room temperature. Should condensation occur, a delay time of approximately 12 hours must be allowed before the unit is switched on.

3.1.2 Unpacking

Proceed as follows to unpack the unit:

1. Remove packaging.
2. Do not discard the original packaging. Keep it for future relocation.
3. Check the delivery for completeness by comparing it with your order.
4. Please keep the associated paperwork. It contains important information for handling the unit.
5. Check the contents for visible shipping damage.

If you notice any shipping damage or inconsistencies between the contents and your order, you should notify Beckhoff Service.

3.2 Mounting

On delivery the battery pack C9900-U332-0010 is provided for vertical installation. By modification of the mounting plate the battery pack can also be used for horizontal installation on the top hat rail.

	Circulation of air
Note	When the unit is installed in an enclosure, adequate space for ventilation must be provided.

	Avoid extreme environmental conditions
Attention	Extreme environmental conditions should be avoided as far as possible. Protect the battery pack from dust, moisture and heat.

3.2.1 Vertical Installation

Battery pack
C9900-U332-0010,
vertical installation
on delivery



The electrical connections (1) are located at the front of the unit.

The rear of the battery pack is installed on a top hat rail (2) of type TS 35 x 15 in the control cabinet. The battery pack is fixed on the rail from the front side with the four allen screws (3), using an allen wrench size 3.0.

3.2.2 Horizontal Installation

After modification of the mounting plate (see also chapter [Modification of the mounting plate](#)) the battery pack can be installed in horizontal position on the top hat rail.

Battery pack
C9900-U332-0010,
horizontal installation

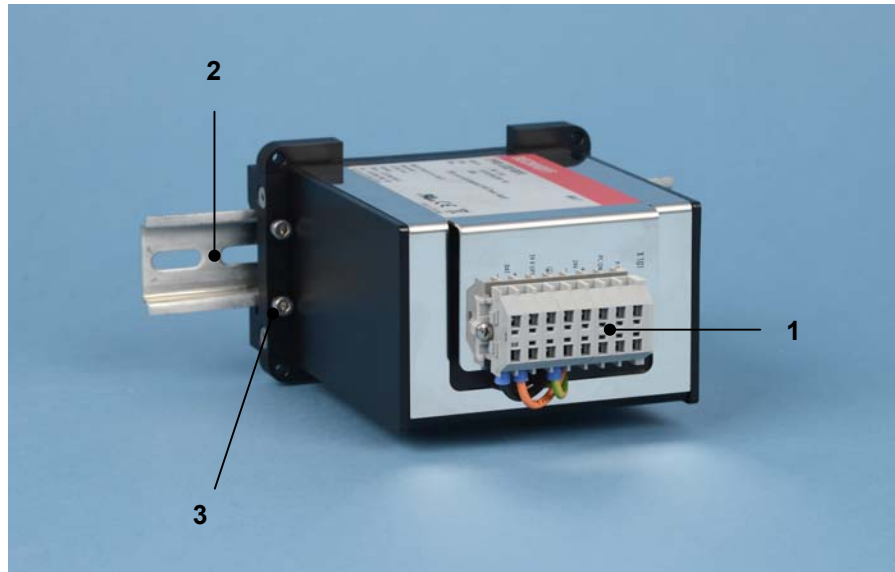

The electrical connections (1) are located at the front of the unit.

The rear of the battery pack is installed on a top hat rail (2) of type TS 35 x 15 in the control cabinet. The battery pack is fixed on the rail from the front side with the four allen screws (3), using an allen wrench size 3.0.

3.2.3 Modification of the mounting plate

After modification of the mounting plate the battery pack can be installed in horizontal position on the top hat rail. Proceed as follows:

Rear view,
vertical orientation
on delivery

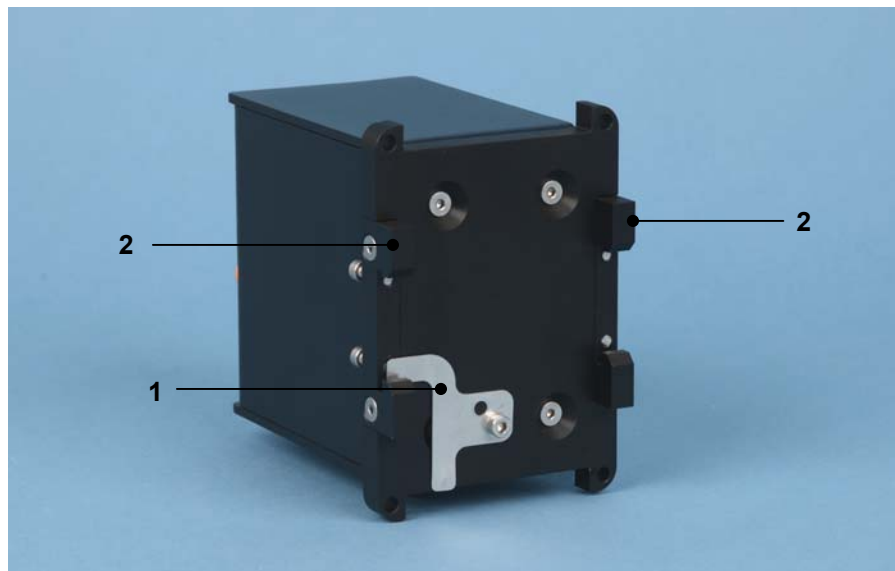

1. Remove the sheet for the ground connection (1), using an allen wrench size 3.0.
2. Remove the two mounting notches (2), using an allen wrench size 2.5.
3. Rotate the battery pack about 90 degrees as shown on the following picture.

Rear view,
horizontal orientation



5. Mount the sheet for the ground connection (1) at the position shown on the picture, using an allen wrench size 3.0.
6. Mount the two mounting notches (2), using an allen wrench size 2.5.

The battery pack can now be installed on the top hat rail.

3.3 Connecting the Battery Pack

 Attention	<p>Connecting cables</p> <p>Please read the documentation for the external devices prior to connecting them!</p> <p>During thunderstorms, plug connector must neither be inserted nor removed!</p> <p>Disconnect the devices from the power supply!</p> <p>When disconnecting a plug connector, always handle it at the plug. Do not pull the cable!</p>
---	---

3.3.1 Pin assignment of the Connector

The 8-pin terminal strip (X101) shown in the photograph is mounted on the battery pack housing for connecting the pack with the power supply unit of the Industrial PC.

Connection terminal strip at the battery pack

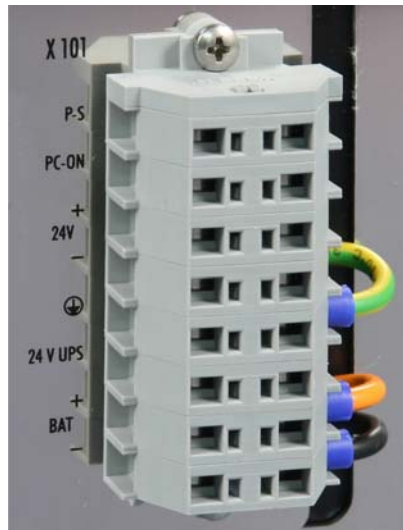

Pin	Function
1	- BAT
2	+ BAT
3	UPS+ (Output)
4	⊕
5	- 24 V DC
6	+ Power Supply
7	PC_ON
8	Power-Status

 Note	<p>Loop through the cables</p> <p>Only the functions BAT+, BAT- and protective ground are directly wired with the battery pack. The other terminals can be used for looping through the cable set.</p>
--	---

 Note	<p>Conductive cross-section</p> <p>The connector is specified for 16 A and can lift conductive cross-sections until 1.5 mm².</p>
--	--

4 Operating Instructions

4.1 Appropriate Use

The battery pack C9900-U332-0010 is designed for use with the following devices with Intel® Atom™ processor: CP62xx-xxxx-0020 und C6915.

4.2 Operation

For operation, please read the appropriate power supply manual.

4.3 Servicing and maintenance

4.3.1 Cleaning

 DANGER	<p>Disconnect power supply</p> <p>Switch off the device and all connected devices, and disconnect the device from the power supply.</p>
--	--

The device can be cleaned with a soft, damp cleaning cloth. Do not use any aggressive cleaning materials, thinners, scouring material or hard objects that could cause scratches.

4.3.2 Maintenance

The battery pack is maintenance-free.

4.4 Emergency procedures

In case of fire, the battery pack should be extinguished with dry chemical, foam, halon or CO₂.

 DANGER	<p>Special Fire Fighting Procedures</p> <p>Turn off power! Use positive pressure, self-contained breathing apparatus in fighting fire! Water applied to electrolyte generates heat and causes it to splatter! Wear acid resistant clothing! Ventilate area well!</p>
--	---

4.5 Shutting down

4.5.1 Disposal

 Note	<p>Observe national electronics scrap regulations</p> <p>Observe the national electronics scrap regulations when disposing of the device.</p>
--	--

In order to dispose of the device, it must be removed and fully dismantled:

- Housing components (polycarbonate, polyamide (PA6.6)) are suitable for plastic recycling.
- Metal parts can be sent for metal recycling.
- Electronic parts such as disk drives and circuit boards must be disposed of in accordance with national electronics scrap regulations.

5 Assembly dimensions

 Warning	<p>Notice mounting orientation</p> <p>The assembly of the unit must take place with the orientation diagrammed here.</p>
---	---

Battery pack C9900-U332-0010 (maximum device dimensions in mm)

Vertical installation on top hat rail

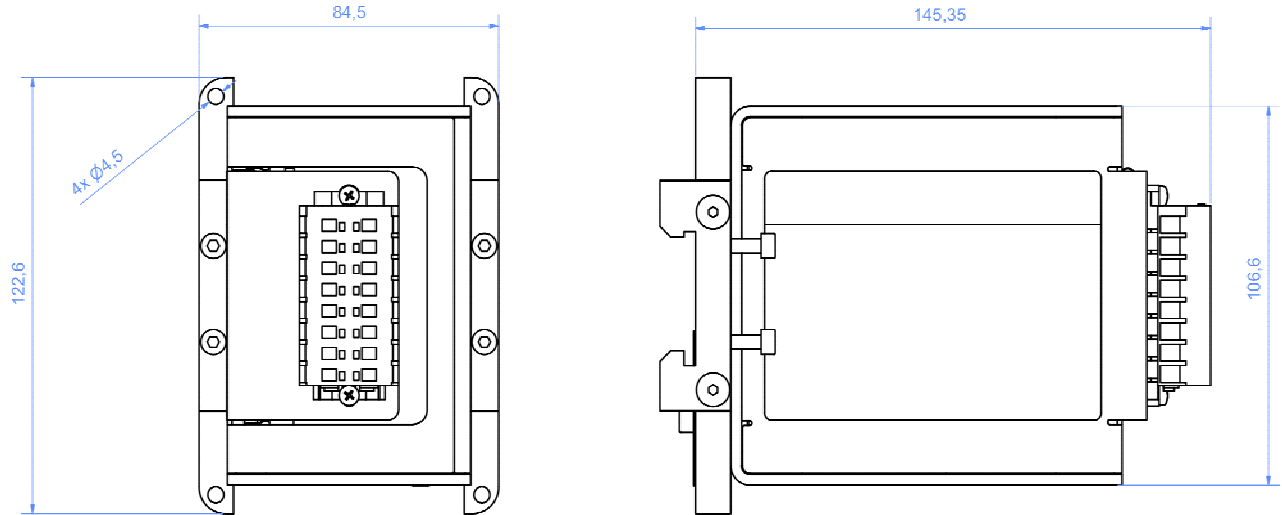

Horizontal installation on top hat rail

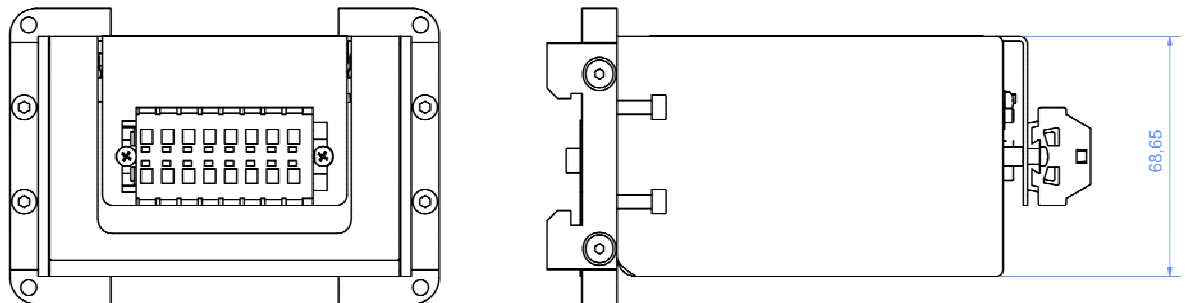

Hole pattern for mounting without top hat rail

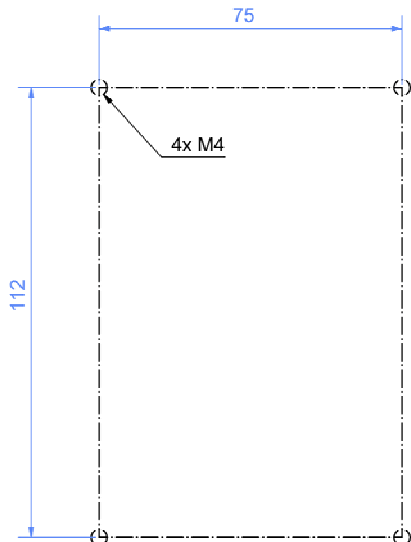



6 Wiring diagram

 Danger	<p>Risk of explosion!</p> <p>Do not use the battery pack in areas of explosive hazard!</p>
--	---

Wiring diagram external switch and power supply

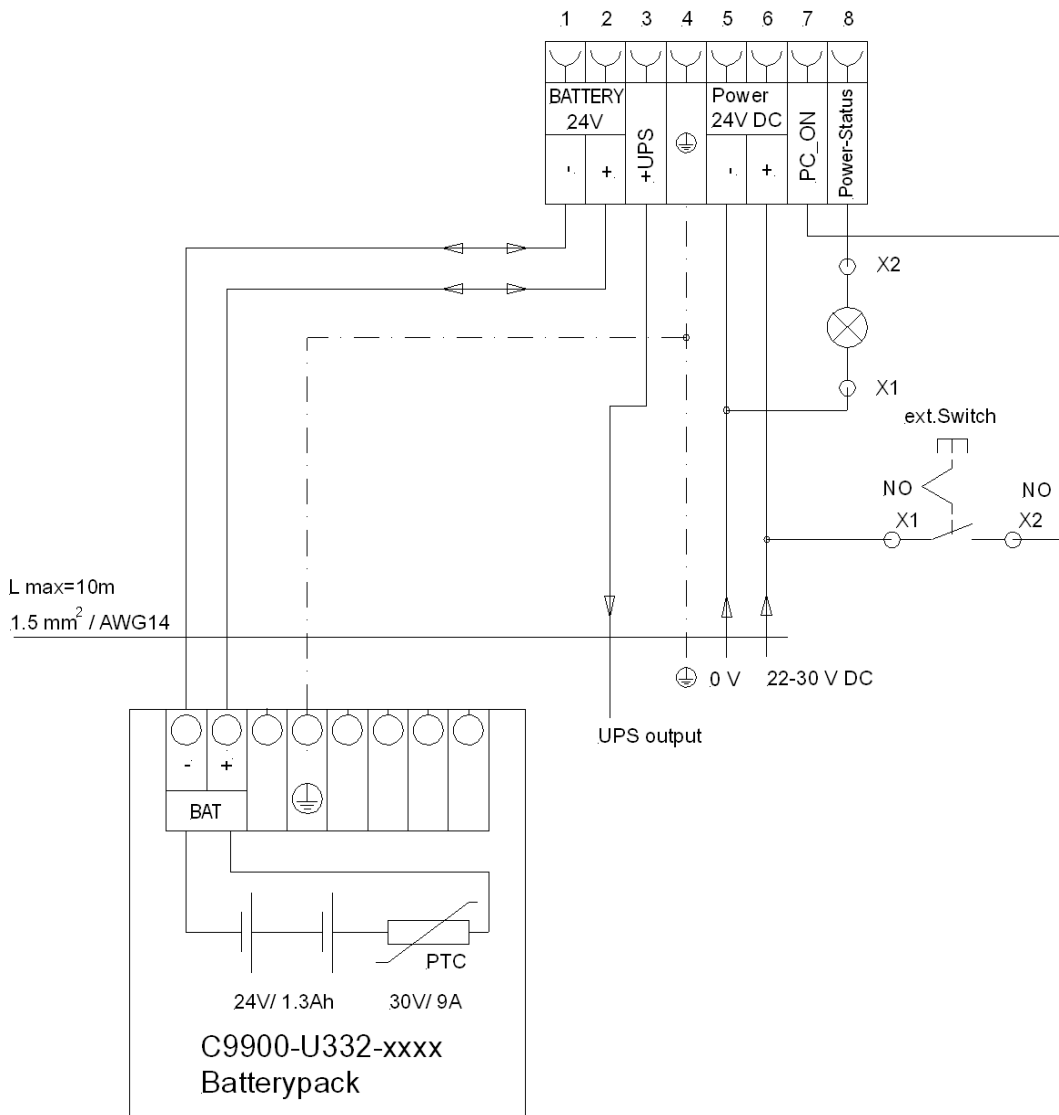
Wiring according to the wiring diagram (the circuit of PC_ON and Power-Status is symbolical):



 Note	<p>Connection of the Battery Pack and UPS Output</p> <p>Connection of the battery pack and UPS Output only in combination with integrated UPS (order option).</p>
--	--

7 Technical Data

 Danger	Risk of explosion! Do not use the battery pack in areas of explosive hazard!
--	--

Product name	C9900-U332-0010
Dimensions (B x H x T)	see chapter Assembly dimensions
Weight	2.4 kg
Electrical data	Nominal voltage: 24 V Capacity: 1,3 Ah (discharge over 20 hours) Internal resistance: 180 mOhm Protection: 9 A/ 30 V via PTC element Final charge voltage: between 27.2 V and 27.4 V
Shock resistance (Sinusoidal vibration)	EN 60068-2-6: 10 to 58 Hz: 0,035 mm 58 to 500 Hz: 0,5 G (~ 5 m/ s ²)
Shock resistance (Shock)	EN 60068-2-27: 5 G (~ 50 m/ s ²), duration: 30 ms
EMC compatibility	Resistance to interference conforms to EN 61000-6-2
Permissible ambient temperature	0°C to +50°C (operation/ storage) -20°C to +50°C (transport)
Permissible relative humidity	to 95%, no condensation
Transport and storage	The same values for atmospheric humidity and shock resistance are to be observed during transport and storage as in operation. Suitable packaging of the battery pack can improve the resistance to impact during transport.
Certifications	CE, UL

8 Appendix

8.1 Beckhoff Support and Service

Beckhoff and their partners around the world offer comprehensive support and service, making available fast and competent assistance with all questions related to Beckhoff products and system solutions.

8.1.1 Beckhoff branches and partner companies

Please contact your Beckhoff branch office or partner company for [local support and service](#) on Beckhoff products!

The contact addresses for your country can be found in the list of Beckhoff branches and partner companies: www.beckhoff.com. You will also find further [documentation](#) for Beckhoff components there.

8.1.2 Beckhoff company headquarters

Beckhoff Automation GmbH & Co. KG
Huelshorstweg 20
33415 Verl
Germany

Phone: + 49 (0) 5246/963-0
Fax: + 49 (0) 5246/963-198
E-mail: info@beckhoff.de
Web: <http://www.beckhoff.de/>

Beckhoff Support

Support offers you comprehensive technical assistance, helping you not only with the application of individual Beckhoff products, but also with other, wide-ranging services:

- world-wide support
- design, programming and commissioning of complex automation systems
- and extensive training program for Beckhoff system components

Hotline: + 49 (0) 5246/963-157
Fax: + 49 (0) 5246/963-9157
E-mail: support@beckhoff.com

Beckhoff Service

The Beckhoff Service Center supports you in all matters of after-sales service:

- on-site service
- repair service
- spare parts service
- hotline service

Hotline: + 49 (0) 5246/963-460
Fax: + 49 (0) 5246/963-479
E-mail: service@beckhoff.com

If servicing is required, please quote the **project number** of your product.

8.2 Approvals for USA and Canada

8.3 FCC Approvals for the United States of America

FCC: Federal Communications Commission Radio Frequency Interference Statement

This equipment has been tested and found to comply with the limits for a Class A digital device, pursuant to Part 15 of the FCC Rules. These limits are designed to provide reasonable protection against harmful interference when the equipment is operated in a commercial environment. This equipment generates, uses, and can radiate radio frequency energy and, if not installed and used in accordance with the instruction manual, may cause harmful interference to radio communications. Operation of this equipment in a residential area is likely to cause harmful interference in which case the user will be required to correct the interference at his own expense.

**Note****Technical modifications**

Technological changes to the device may cause the loss of the FCC approval.

8.4 FCC Approval for Canada

FCC: Canadian Notice

This equipment does not exceed the Class A limits for radiated emissions as described in the Radio Interference Regulations of the Canadian Department of Communications.