



Documentation

EK18xx

EtherCAT Bus Coupler

Version: 2.2
Date: 03.04.2019

BECKHOFF

1 Product overview EtherCAT Bus Coupler

[EK1814](#) [▶ [20](#)] EtherCAT Bus Coupler with 4 digital inputs and 4 digital outputs

[EK181](#) [▶ [20](#)]8 EtherCAT Bus Coupler with 8 digital inputs and 4 digital outputs

[EK1828](#) [▶ [20](#)] EtherCAT Bus Coupler with 4 digital inputs and 8 digital outputs

[EK1828-0010](#) [▶ [20](#)] EtherCAT Bus Coupler with 8 digital outputs

Table of contents

1	Product overview EtherCAT Bus Coupler	3
2	Foreword	7
2.1	Notes on the documentation	7
2.2	Safety instructions	8
2.3	Documentation issue status	9
2.4	Version identification of EtherCAT devices	9
3	Basic principles	14
3.1	EtherCAT basics	14
3.2	EtherCAT cabling – wire-bound	14
3.3	EtherCAT State Machine	15
3.4	CoE - Interface: notes	16
3.5	Distributed Clock	16
4	Product overview	18
4.1	Overview of EtherCAT couplers EK18xx	18
4.2	EK18xx	20
4.2.1	Introduction	20
4.2.2	Technical data	21
4.2.3	Optional distributed clocks support	22
4.2.4	EtherCAT coupler port allocation	24
5	Mounting and wiring	27
5.1	Instructions for ESD protection	27
5.2	Installation on mounting rails	27
5.3	Connection system	30
5.4	Positioning of passive Terminals	34
5.5	Power supply, potential groups	34
5.6	EK18xx - connection	37
5.6.1	EK1814 - connection	37
5.6.2	EK1818 - connection	38
5.6.3	EK1828 - connection	39
5.6.4	EK1828-0010 - connection	40
6	Parameterization and commissioning	41
6.1	Configuration overview	41
6.2	Overview of process data	41
6.2.1	EK1814	41
6.2.2	EK1818	44
6.2.3	EK1828	47
6.2.4	EK1828-0010	51
7	Error handling and diagnostics	54
7.1	Diagnostic LEDs	54
8	Appendix	56
8.1	UL notice	56
8.2	Firmware compatibility	57

8.3	Firmware Update EL/ES/EM/ELM/EPxxxx	58
8.3.1	Device description ESI file/XML.....	59
8.3.2	Firmware explanation	62
8.3.3	Updating controller firmware *.efw	63
8.3.4	FPGA firmware *.rbf.....	64
8.3.5	Simultaneous updating of several EtherCAT devices.....	68
8.4	Support and Service	69

2 Foreword

2.1 Notes on the documentation

Intended audience

This description is only intended for the use of trained specialists in control and automation engineering who are familiar with the applicable national standards.

It is essential that the documentation and the following notes and explanations are followed when installing and commissioning these components.

It is the duty of the technical personnel to use the documentation published at the respective time of each installation and commissioning.

The responsible staff must ensure that the application or use of the products described satisfy all the requirements for safety, including all the relevant laws, regulations, guidelines and standards.

Disclaimer

The documentation has been prepared with care. The products described are, however, constantly under development.

We reserve the right to revise and change the documentation at any time and without prior announcement.

No claims for the modification of products that have already been supplied may be made on the basis of the data, diagrams and descriptions in this documentation.

Trademarks

Beckhoff®, TwinCAT®, EtherCAT®, EtherCAT P®, Safety over EtherCAT®, TwinSAFE®, XFC® and XTS® are registered trademarks of and licensed by Beckhoff Automation GmbH.

Other designations used in this publication may be trademarks whose use by third parties for their own purposes could violate the rights of the owners.

Patent Pending

The EtherCAT Technology is covered, including but not limited to the following patent applications and patents: EP1590927, EP1789857, DE102004044764, DE102007017835 with corresponding applications or registrations in various other countries.

The TwinCAT Technology is covered, including but not limited to the following patent applications and patents: EP0851348, US6167425 with corresponding applications or registrations in various other countries.



EtherCAT® is registered trademark and patented technology, licensed by Beckhoff Automation GmbH, Germany.

Copyright

© Beckhoff Automation GmbH & Co. KG, Germany.

The reproduction, distribution and utilization of this document as well as the communication of its contents to others without express authorization are prohibited.

Offenders will be held liable for the payment of damages. All rights reserved in the event of the grant of a patent, utility model or design.

2.2 Safety instructions

Safety regulations

Please note the following safety instructions and explanations!
Product-specific safety instructions can be found on following pages or in the areas mounting, wiring, commissioning etc.

Exclusion of liability

All the components are supplied in particular hardware and software configurations appropriate for the application. Modifications to hardware or software configurations other than those described in the documentation are not permitted, and nullify the liability of Beckhoff Automation GmbH & Co. KG.

Personnel qualification

This description is only intended for trained specialists in control, automation and drive engineering who are familiar with the applicable national standards.

Description of instructions

In this documentation the following instructions are used.
These instructions must be read carefully and followed without fail!

DANGER

Serious risk of injury!

Failure to follow this safety instruction directly endangers the life and health of persons.

WARNING

Risk of injury!

Failure to follow this safety instruction endangers the life and health of persons.

CAUTION

Personal injuries!

Failure to follow this safety instruction can lead to injuries to persons.

NOTE

Damage to environment/equipment or data loss

Failure to follow this instruction can lead to environmental damage, equipment damage or data loss.



Tip or pointer

This symbol indicates information that contributes to better understanding.

2.3 Documentation issue status

Version	Modifications
2.2	<ul style="list-style-type: none"> • Update chapter "Overview EtherCAT couplers" • Update chapter "Safety instructions" • Update revision status
2.1	<ul style="list-style-type: none"> • Update chapter "Notes on the documentation" • Update chapter "Technical data" • Addenda chapter "Instructions for ESD protection" • Update revision status
2.0	<ul style="list-style-type: none"> • Migration • Update revision status • Update structure
1.3	<ul style="list-style-type: none"> • Update structure • Update revision status • Update chapter "Technical data"
1.2	<ul style="list-style-type: none"> • Addenda chapter "Power Supply, Potential Groups"
1.1	<ul style="list-style-type: none"> • EK1818, EK1828, EK1828-0010 added
1.0	<ul style="list-style-type: none"> • First public issue
0.3	<ul style="list-style-type: none"> • Corrections and addenda
0.2	<ul style="list-style-type: none"> • Corrections and addenda
0.1	<ul style="list-style-type: none"> • Preliminary version

2.4 Version identification of EtherCAT devices

Designation

A Beckhoff EtherCAT device has a 14-digit designation, made up of

- family key
- type
- version
- revision

Example	Family	Type	Version	Revision
EL3314-0000-0016	EL terminal (12 mm, non-pluggable connection level)	3314 (4-channel thermocouple terminal)	0000 (basic type)	0016
ES3602-0010-0017	ES terminal (12 mm, pluggable connection level)	3602 (2-channel voltage measurement)	0010 (high-precision version)	0017
CU2008-0000-0000	CU device	2008 (8-port fast ethernet switch)	0000 (basic type)	0000

Notes

- The elements mentioned above result in the **technical designation**. EL3314-0000-0016 is used in the example below.
- EL3314-0000 is the order identifier, in the case of "-0000" usually abbreviated to EL3314. "-0016" is the EtherCAT revision.

- The **order identifier** is made up of
 - family key (EL, EP, CU, ES, KL, CX, etc.)
 - type (3314)
 - version (-0000)
- The **revision** -0016 shows the technical progress, such as the extension of features with regard to the EtherCAT communication, and is managed by Beckhoff. In principle, a device with a higher revision can replace a device with a lower revision, unless specified otherwise, e.g. in the documentation. Associated and synonymous with each revision there is usually a description (ESI, EtherCAT Slave Information) in the form of an XML file, which is available for download from the Beckhoff web site. From 2014/01 the revision is shown on the outside of the IP20 terminals, see Fig. "EL5021 EL terminal, standard IP20 IO device with batch number and revision ID (since 2014/01)".
- The type, version and revision are read as decimal numbers, even if they are technically saved in hexadecimal.

Identification number

Beckhoff EtherCAT devices from the different lines have different kinds of identification numbers:

Production lot/batch number/serial number/date code/D number

The serial number for Beckhoff IO devices is usually the 8-digit number printed on the device or on a sticker. The serial number indicates the configuration in delivery state and therefore refers to a whole production batch, without distinguishing the individual modules of a batch.

Structure of the serial number: **KK YY FF HH**

KK - week of production (CW, calendar week)
 YY - year of production
 FF - firmware version
 HH - hardware version

Example with

Ser. no.: 12063A02: 12 - production week 12 06 - production year 2006 3A - firmware version 3A 02 - hardware version 02

Exceptions can occur in the **IP67 area**, where the following syntax can be used (see respective device documentation):

Syntax: D ww yy x y z u

D - prefix designation
 ww - calendar week
 yy - year
 x - firmware version of the bus PCB
 y - hardware version of the bus PCB
 z - firmware version of the I/O PCB
 u - hardware version of the I/O PCB

Example: D.22081501 calendar week 22 of the year 2008 firmware version of bus PCB: 1 hardware version of bus PCB: 5 firmware version of I/O PCB: 0 (no firmware necessary for this PCB) hardware version of I/O PCB: 1

Unique serial number/ID, ID number

In addition, in some series each individual module has its own unique serial number.

See also the further documentation in the area

- IP67: [EtherCAT Box](#)
- Safety: [TwinSafe](#)
- Terminals with factory calibration certificate and other measuring terminals

Examples of markings



Fig. 1: EL5021 EL terminal, standard IP20 IO device with serial/ batch number and revision ID (since 2014/01)



Fig. 2: EK1100 EtherCAT coupler, standard IP20 IO device with serial/ batch number

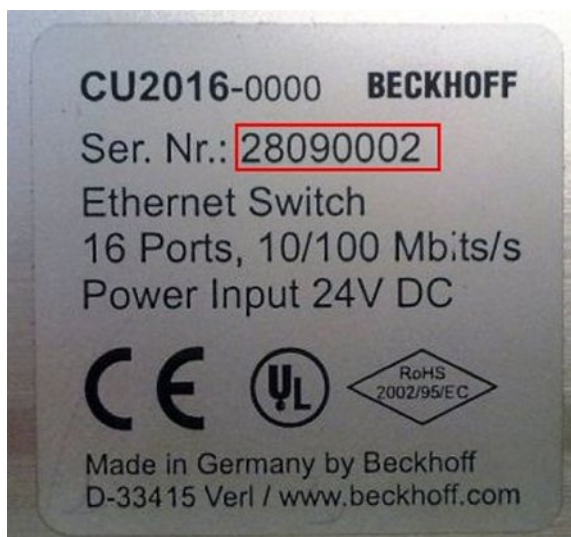

Fig. 3: CU2016 switch with serial/ batch number

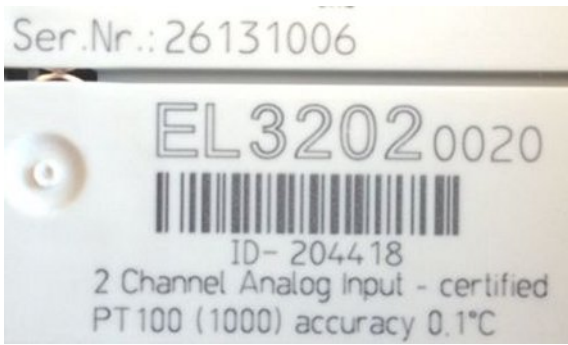

Fig. 4: EL3202-0020 with serial/ batch number 26131006 and unique ID-number 204418

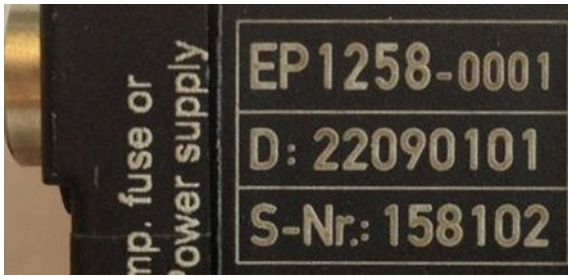

Fig. 5: EP1258-00001 IP67 EtherCAT Box with batch number/ date code 22090101 and unique serial number 158102

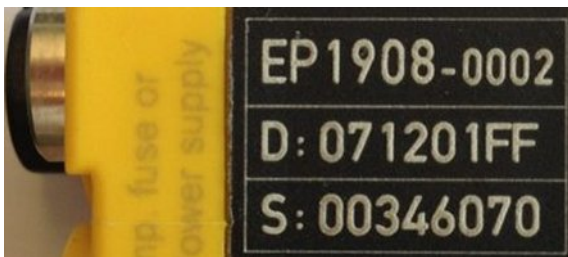

Fig. 6: EP1908-0002 IP67 EtherCAT Safety Box with batch number/ date code 071201FF and unique serial number 00346070



Fig. 7: EL2904 IP20 safety terminal with batch number/ date code 50110302 and unique serial number 00331701



Fig. 8: ELM3604-0002 terminal with unique ID number (QR code) 100001051 and serial/ batch number 44160201

3 Basic principles

3.1 EtherCAT basics

Please refer to the [EtherCAT System Documentation](#) for the EtherCAT fieldbus basics.

3.2 EtherCAT cabling – wire-bound

The cable length between two EtherCAT devices must not exceed 100 m. This results from the FastEthernet technology, which, above all for reasons of signal attenuation over the length of the cable, allows a maximum link length of 5 + 90 + 5 m if cables with appropriate properties are used. See also the [Design recommendations for the infrastructure for EtherCAT/Ethernet](#).

Cables and connectors

For connecting EtherCAT devices only Ethernet connections (cables + plugs) that meet the requirements of at least category 5 (Cat5) according to EN 50173 or ISO/IEC 11801 should be used. EtherCAT uses 4 wires for signal transfer.

EtherCAT uses RJ45 plug connectors, for example. The pin assignment is compatible with the Ethernet standard (ISO/IEC 8802-3).

Pin	Color of conductor	Signal	Description
1	yellow	TD +	Transmission Data +
2	orange	TD -	Transmission Data -
3	white	RD +	Receiver Data +
6	blue	RD -	Receiver Data -

Due to automatic cable detection (auto-crossing) symmetric (1:1) or cross-over cables can be used between EtherCAT devices from Beckhoff.

● Recommended cables

i Suitable cables for the connection of EtherCAT devices can be found on the [Beckhoff website!](#)

E-Bus supply

A bus coupler can supply the EL terminals added to it with the E-bus system voltage of 5 V; a coupler is thereby loadable up to 2 A as a rule (see details in respective device documentation). Information on how much current each EL terminal requires from the E-bus supply is available online and in the catalogue. If the added terminals require more current than the coupler can supply, then power feed terminals (e.g. [EL9410](#)) must be inserted at appropriate places in the terminal strand.

The pre-calculated theoretical maximum E-Bus current is displayed in the TwinCAT System Manager. A shortfall is marked by a negative total amount and an exclamation mark; a power feed terminal is to be placed before such a position.

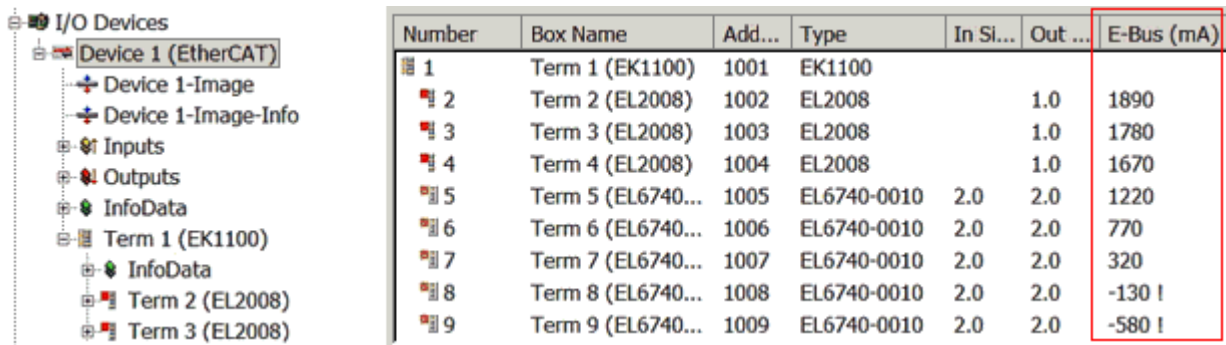

Fig. 9: System manager current calculation

NOTE

Malfunction possible!
 The same ground potential must be used for the E-Bus supply of all EtherCAT terminals in a terminal block!

3.3 EtherCAT State Machine

The state of the EtherCAT slave is controlled via the EtherCAT State Machine (ESM). Depending upon the state, different functions are accessible or executable in the EtherCAT slave. Specific commands must be sent by the EtherCAT master to the device in each state, particularly during the bootup of the slave.

A distinction is made between the following states:

- Init
- Pre-Operational
- Safe-Operational and
- Operational
- Boot

The regular state of each EtherCAT slave after bootup is the OP state.

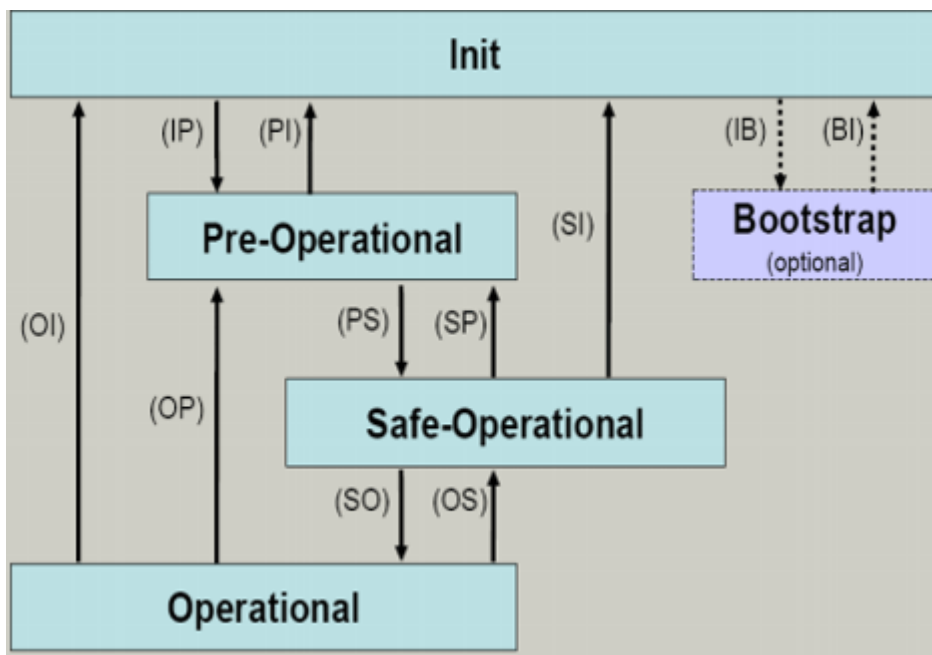

Fig. 10: States of the EtherCAT State Machine

Init

After switch-on the EtherCAT slave in the *Init* state. No mailbox or process data communication is possible. The EtherCAT master initializes sync manager channels 0 and 1 for mailbox communication.

Pre-Operational (Pre-Op)

During the transition between *Init* and *Pre-Op* the EtherCAT slave checks whether the mailbox was initialized correctly.

In *Pre-Op* state mailbox communication is possible, but not process data communication. The EtherCAT master initializes the sync manager channels for process data (from sync manager channel 2), the FMMU channels and, if the slave supports configurable mapping, PDO mapping or the sync manager PDO assignment. In this state the settings for the process data transfer and perhaps terminal-specific parameters that may differ from the default settings are also transferred.

Safe-Operational (Safe-Op)

During transition between *Pre-Op* and *Safe-Op* the EtherCAT slave checks whether the sync manager channels for process data communication and, if required, the distributed clocks settings are correct. Before it acknowledges the change of state, the EtherCAT slave copies current input data into the associated DP-RAM areas of the EtherCAT slave controller (ECSC).

In *Safe-Op* state mailbox and process data communication is possible, although the slave keeps its outputs in a safe state, while the input data are updated cyclically.

**Outputs in SAFEOP state**

The default set watchdog monitoring sets the outputs of the module in a safe state - depending on the settings in SAFEOP and OP - e.g. in OFF state. If this is prevented by deactivation of the watchdog monitoring in the module, the outputs can be switched or set also in the SAFEOP state.

Operational (Op)

Before the EtherCAT master switches the EtherCAT slave from *Safe-Op* to *Op* it must transfer valid output data.

In the *Op* state the slave copies the output data of the masters to its outputs. Process data and mailbox communication is possible.

Boot

In the *Boot* state the slave firmware can be updated. The *Boot* state can only be reached via the *Init* state.

In the *Boot* state mailbox communication via the *file access over EtherCAT* (FoE) protocol is possible, but no other mailbox communication and no process data communication.

3.4 CoE - Interface: notes

This device has no CoE.

Detailed information on the CoE interface can be found in the [EtherCAT system documentation](#) on the Beckhoff website.

3.5 Distributed Clock

The distributed clock represents a local clock in the EtherCAT slave controller (ESC) with the following characteristics:

- Unit 1 ns
- Zero point 1.1.2000 00:00

- Size *64 bit* (sufficient for the next 584 years; however, some EtherCAT slaves only offer 32-bit support, i.e. the variable overflows after approx. 4.2 seconds)
- The EtherCAT master automatically synchronizes the local clock with the master clock in the EtherCAT bus with a precision of < 100 ns.

For detailed information please refer to the [EtherCAT system description](#).

4 Product overview

4.1 Overview of EtherCAT couplers EK18xx

An EtherCAT coupler is required in order to connect EtherCAT Terminals with E-bus-communication (series ELxxxx, ESxxxx, EMxxxx) to an EtherCAT network. This coupler relays the communication from the higher-level EtherCAT network to the terminals, or functions as a master itself and generates telegrams. Beckhoff offers different components for different application scenarios.

The selection of the correct coupler depends on the following criteria:

- is a local small controller needed?
- is the coupler to be connected via copper cable or optical fiber cable?
- is the coupler to be addressed via IP or is it located in the unswitched network?
- is the coupler to be controlled via EAP (EtherCAT Automation Protocol) or EtherCAT Device Protocol?
- required protection class: IP20 or higher?
- is the coupler to be plugged in at different places at the network using the HotConnect technique?

A coupler connects the added terminals to the right; it can be connected to the higher level network to the left. Couplers that support the EtherCAT Device Protocol 'to the left' must be connected there to an EtherCAT master.

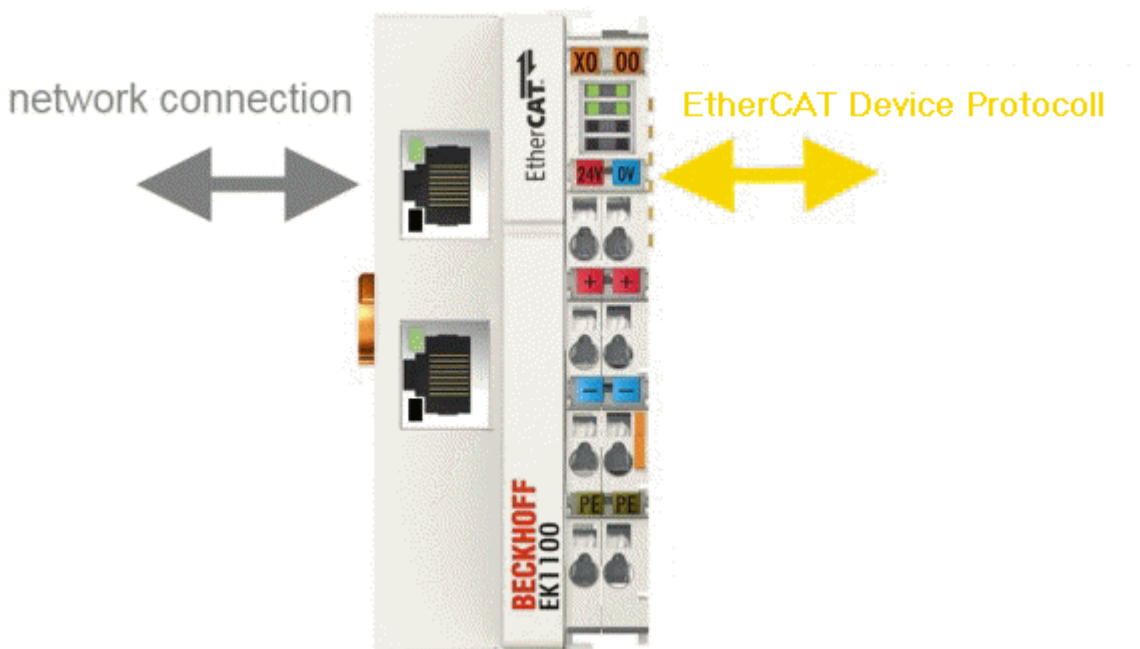

Fig. 11: EtherCAT coupler communication diagram

The following overview can be used for selection:

Characteristic	EK1100	EK1101 EK1101-0080	EK1101-0010	EK1300	EK1501	EK1501-0010
Protection class	IP20	IP20	IP20	IP20	IP20	IP20
Higher level network technology	100 MBit FastEthernet (100BASE-TX)	100 MBit FastEthernet (100BASE-TX)	100 MBit FastEthernet (100BASE-TX)	100 MBit FastEthernet (100BASE-TX)	100 MBit FastEthernet (100BASE-FX)	100 MBit FastEthernet (100BASE-FX)
Higher level network - max. connection length	100 m	100 m	300 m	100 m	2 km	20 km
Higher level network connection technology	RJ45	RJ45	RJ45	2 x M8 socket, shielded, screw type, EtherCAT-P-code	SC duplex Multi-mode optical fiber cable	SC duplex Single-mode optical fiber cable
Higher-level network protocol	EtherCAT Device Protocol (formerly Direct Mode)	EtherCAT Device Protocol (formerly Direct Mode)	EtherCAT Device Protocol (formerly Direct Mode)	EtherCAT Device Protocol (to 100BASE-TX EtherCAT P networks)	EtherCAT Device Protocol (formerly Direct Mode)	EtherCAT Device Protocol (formerly Direct Mode)
integrated PLC	-	-	-	-	-	-
supports HotConnect with address setting on the device	-	yes EK1101-0080: Fast-Hot-Connect	-	-	yes	yes
Note	The EK1100 is the "standard" coupler for use directly on the EtherCAT master.		Distance between stations: max. 300 m (copper, Cat. 5, 4-wire).	Coupling of EtherCAT Terminals (ELxxxx) to 100BASE-TX EtherCAT P networks		

Characteristic	EK1541	EK18xx	EK9000	EKx000	EPxxxx	CX8000
Protection class	IP20	IP20	IP20	IP20	IP67	IP20
Higher level network technology	100 MBit FastEthernet (100BASE-FX) POF	100 MBit FastEthernet (100BASE-TX)	100 MBit FastEthernet (100BASE-TX)	diverse see doc.	100 MBit FastEthernet (100BASE-TX)	100 MBit FastEthernet (100BASE-TX)
Higher level network - max. connection length	50 m	100 m	100 m	see doc.	100 m	100 m
Higher level network connection technology	Versatile Link POF duplex connector Polymeric Optical Fiber	RJ45	RJ45	s.Doc	M8	RJ45
Higher-level network protocol	EtherCAT Device Protocol (formerly Direct Mode)	EtherCAT Device Protocol (formerly Direct Mode)	EAP	see doc.	EtherCAT Device Protocol (formerly Direct Mode)	EtherCAT Device Protocol (formerly Direct Mode)
integrated PLC	-	-	-	-	-	yes
supports HotConnect with address setting on the device	yes	-	-	-	-	-
Note		The EK18xx devices integrate a coupler for application directly at the EtherCAT master and digital inputs and outputs without additional wiring.	The EK9000 can be controlled in a switched EtherCAT network with directed IP addressing.	If the EK9000 is provided with another fieldbus connection, this gives rise to the appropriate EKx000 coupler.	Technologically, each EP Box represents a self-contained EtherCAT coupler with internally added I/O functions.	The CX8000 appears to the higher level EtherCAT network as an EtherCAT slave while at the same time managing its attached I/Os as a master.

4.2 EK18xx

4.2.1 Introduction



Fig. 12: EK18xx

EK18xx EtherCAT coupler with digital inputs and outputs

The EK18xx EtherCAT couplers link the EtherCAT device protocol with the EtherCAT Terminals (ELxxxx/ESxxxx/EMxxxx). Depending on the type, they contain a certain number of digital inputs 24 V_{DC} (IEC61131-2 type 3) and outputs 24 V_{DC}; 0.5 A. The coupler in a modern High-Density (HD) housing can be wired using the toolless direct plug-in technique.

One station consists of a coupler, any number of EtherCAT Terminals and a bus end terminal, e.g. EL9011.

The coupler converts the telegrams from Ethernet 100BASE-TX to E-bus signal representation in passing with minimum latency. The coupler is connected to the network via the upper Ethernet interface. The lower RJ-45 socket may be used to connect further EtherCAT devices in the same strand.

The coupler supplies the connected terminals with the necessary E-bus current for communication. The coupler can supply a maximum of 5 V/1000 mA. Power feed terminals (e.g. EL9410) must be integrated if more current is required.

In the EtherCAT network, the EK1100 coupler can be installed anywhere in the Ethernet signal transfer section (100BASE-TX). The coupler thereby processes exclusively unaddressed MAC Broadcast telegrams of the type EtherCAT Device Protocol from the EtherCAT master. Since directed addressing via MAC Unicast or IP addressing is not used, neither a switch nor a router can be used.

4.2.2 Technical data

Technical data	EK1814-0000	EK1818-0000	EK1828-0000	EK1828-0010
Task in the EtherCAT system	Coupling of EtherCAT Terminals (ELxxxx) to 100BASE-TX EtherCAT networks			
Number of digital inputs	4	8	4	-
Number of simultaneously controllable inputs, depending on the ambient temperature ▶ 21	4 (-25 °C ... +60 °C)	8 (-25 °C ... +55 °C) 4 (> +55 °C)	4 (-25 °C ... +60 °C)	-
Number of digital outputs	4	4	8	8
Number of EtherCAT Terminals	up to 65534 in the overall system			
Number of peripheral signals	max. 4.2 GB addressable IO points			
Protocol / Baud rate	EtherCAT Device Protocol / 100 MBaud			
Cable length between two Bus Couplers	max. 100 m (100BASE-TX)			
Transmission medium	at least Ethernet CAT-5 cable			
Nominal voltage of the inputs	24 V _{DC} (-15% / +20%)			-
Signal voltage "0"	-3 V ... 5 V (EN 61131-2, type 1/3)			-
Signal voltage "1"	11 V ... 30 V (EN 61131-2, type 3)			-
Input filter	3 ms			-
Input current	typically 3 mA (EN 61131-2, type 3)			-
Load type	ohmic, inductive, lamp load			
Rated voltage of the outputs	24 V _{DC} (-15% / +20%)			
Switching times	T _{ON} : 60 µs typ.; T _{OFF} : 300 µs typ.			
Output current per channel	max. 0.5 A (short-circuit-proof)			
Short circuit current	< 2 A typ.			
Breaking energy (inductive)	max. 150 mJ/channel			
Distributed Clocks	no			
HotConnect	no			
Delay	typical 1 µs			
Bus connection	2 x RJ45			
Power supply	24 V _{DC} (-15%/+20%)			
Current consumption from U _p	40 mA + load			
Current consumption from U _s	100 mA + (total E-bus current)/4			
E-bus power supply (5 V)	max. 1000 mA (in case of higher current consumption, please use additional EL9410 power feed terminals!)			
Power contacts	max. 24 V _{DC} , max. 10 A			
Electrical isolation	500 V (power contact/supply voltage/EtherCAT) 500 V (E-bus/field voltage)			
Dimensions (W x H x D)	approx. 44 mm x 100 mm x 68 mm			
Weight	approx. 125 g			
Permissible ambient temperature range during operation	-25 °C ... +60 °C (extended temperature range)			
Permissible ambient temperature range during storage	-40 °C ... +85 °C			
Permissible relative humidity	95%, no condensation			
Mounting ▶ 27	on 35 mm mounting rail conforms to EN 60715			
Vibration/shock resistance	conforms to EN 60068-2-6 / EN 60068-2-27			
EMC immunity/emission	conforms to EN 61000-6-2 / EN 61000-6-4			
Protection class	IP20			
Installation position	variable			
Approval	CE cULus ▶ 56			

4.2.3 Optional distributed clocks support

Basic principles Distributed Clocks (DC)

The EtherCAT Distributed Clocks system comprises local clocks that are integrated in the EtherCAT slaves and are synchronized by the EtherCAT master via special datagrams. Not all EtherCAT slaves support the Distributed Clocks procedure. It is only supported by slaves whose function requires it. In the TwinCAT System Manager a slave indicates its DC capability by showing “DC” in the settings dialog.

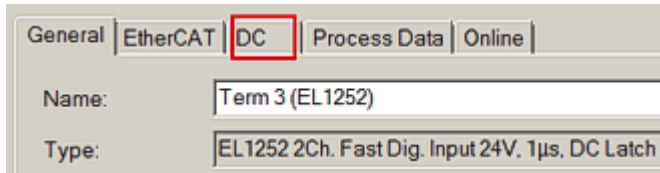

Fig. 13: DC tab for indicating the Distributed Clocks function

Once of these local clocks is the reference clock, based on which all other clocks are synchronized. See also explanatory notes in the [Basic EtherCAT documentation](#). The reference clock must be the first DC-capable EtherCAT slave. By default TwinCAT therefore selects the first DC-capable device as reference clock. This is shown (and can be modified by the user) under advanced properties of the EtherCAT master. The standard setting should not be changed, except in cases where external synchronization is recommended in the relevant documentation, for example.

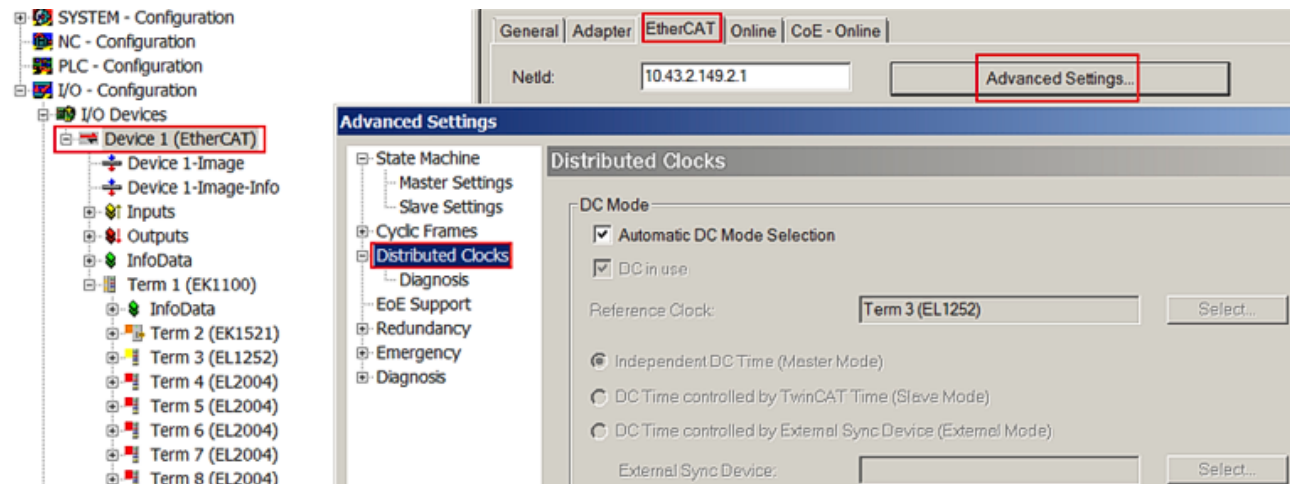

Fig. 14: Advanced Distributed Clocks settings in the EtherCAT master

Fig. *Advanced distributed clocks settings in the EtherCAT master* illustrates how TwinCAT selects the EL1252 as reference clock by default, since the preceding components do not support DC.

Settings EtherCAT device

System and infrastructure devices such as EK1100 or EK1122 couplers and junction etc. do not require Distributed Clocks to function properly. Nevertheless, it may be topologically expedient to designate the first coupler in an EtherCAT system as reference clock, for example. For this reason, from a certain level the infrastructure components are able to operate as reference clocks, based on special configuration settings.

The components support activation of Distributed Clocks, based on the following table:

Device	XML revision in the configuration	Serial number of the component
BK1150	from BK1150-0000-0016	from firmware 01: xxxx01yy
CU1128	from CU1128-0000-0000	from firmware 00: xxxx00yy
EK1100	from EK1100-0000-0017	from firmware 06: xxxx06yy
EK1101	from EK1101-0000-0017	from firmware 01: xxxx01yy
EK1501	from EK1501-0000-0017	from firmware 01: xxxx01yy
EK1501-0010	from EK1501-0010-0017	from firmware 02: xxxx02yy
EK1122	from EK1122-0000-0017	from firmware 01: xxxx02yy
EK1521	from EK1521-0000-0018	from firmware 03: xxxx03yy
EK1541	from EK1541-0000-0016	from firmware 01: xxxx01yy
EK1561	from EK1561-0000-0016	from firmware 01: xxxx01yy
EK1521-0010	from EK1521-0010-0018	from firmware 03: xxxx03yy
EK1814	from EK1814-0000-0016	from firmware 00: xxxx00yy

Table 1: DC support from rev/firmware version

To ensure that TwinCAT uses such a component as DC reference clock, a manual intervention during the configuration setup is required, as shown here using the EK1100 as an example. The checkboxes “Cyclic Mode Enable” and “Use as potential Reference Clock” must be set.

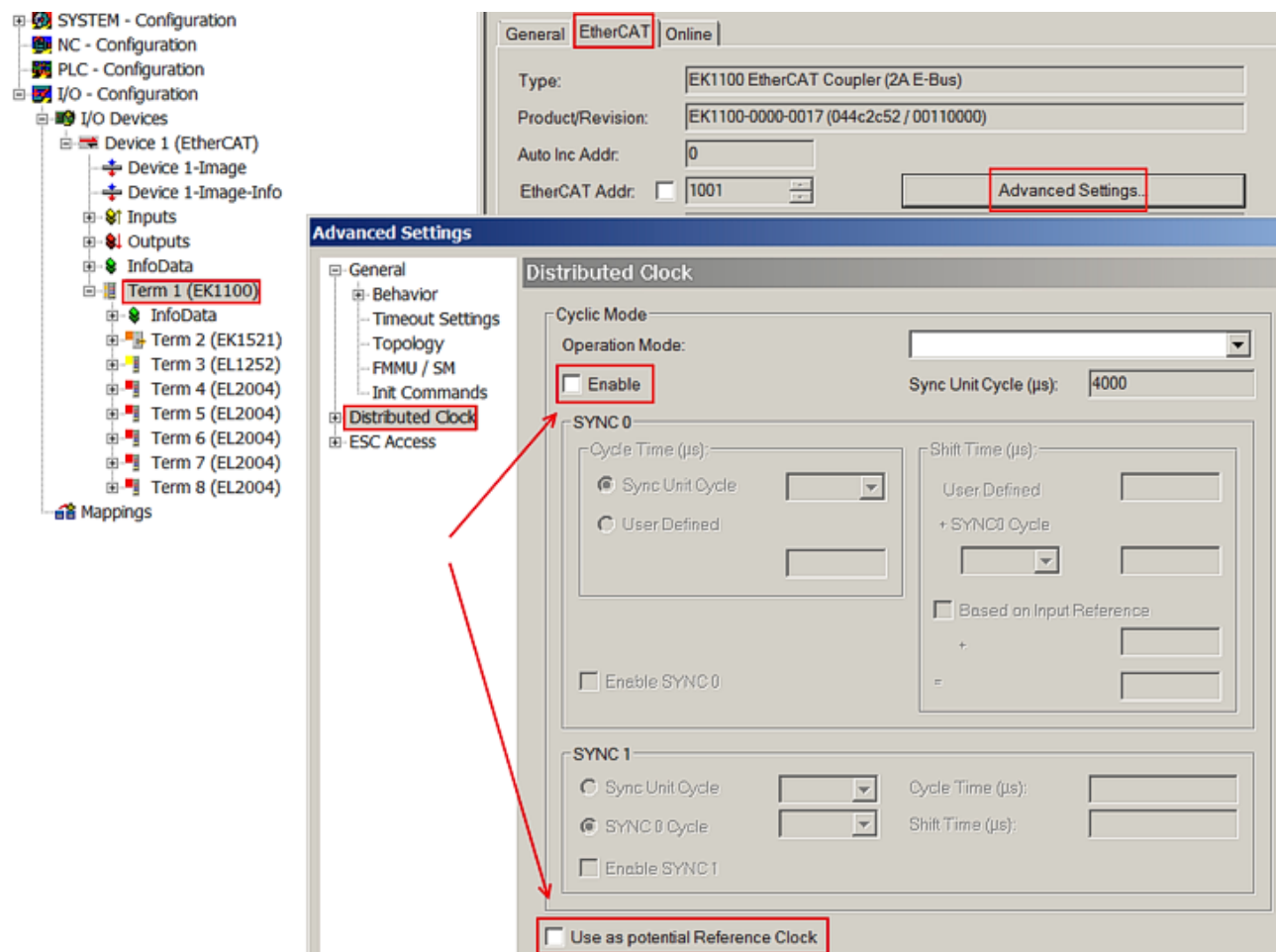

Fig. 15: TwinCAT setting for using this component as reference clock

● Activation of Distributed Clocks support

i The (synchronization) procedure described here is only successful for the components described above. The checkboxes can be set for other components, too, although the hardware does not support this function, unless specified in the respective documentation. In particular, please note that after commissioning the component may not be replaced with a previous version without DC support.

4.2.4 EtherCAT coupler port allocation

According to the EtherCAT specification, an ESC (EtherCAT Slave Controller, hardware processing unit of the EtherCAT protocol) can have 1 to 4 ports, which it controls itself. Via an open port it can handle outgoing and incoming Ethernet traffic.

The direction of data flow in a fully wired EK1100 is shown in Fig. *Internal and external port assignment for Bus Coupler EK1100*:

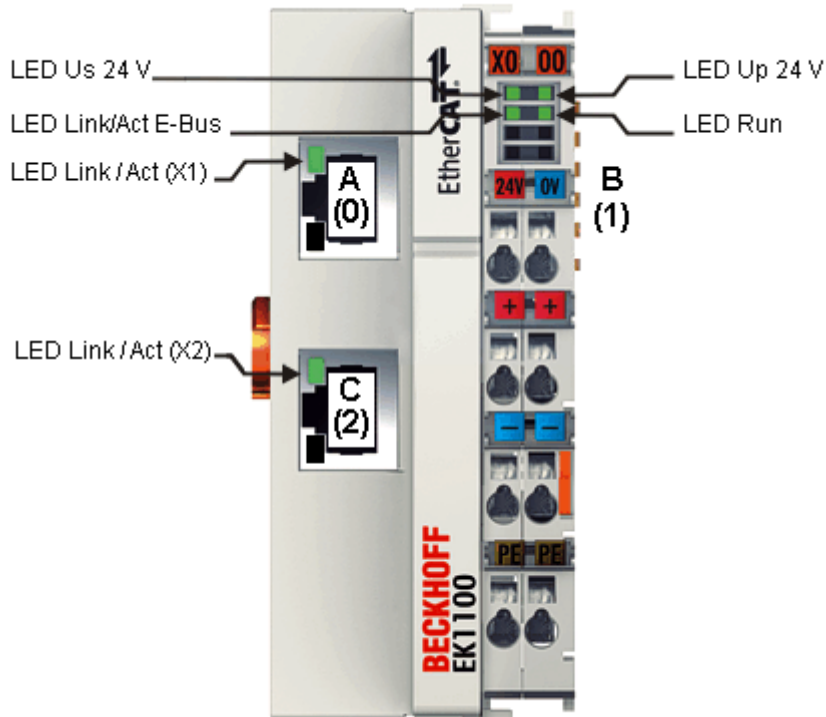

Fig. 16: Example of an EK1100 EtherCAT coupler with 3 ports

The port assignment in the case of the EK1101, EK1501 and EK1501-0010, EK1814 applies accordingly.

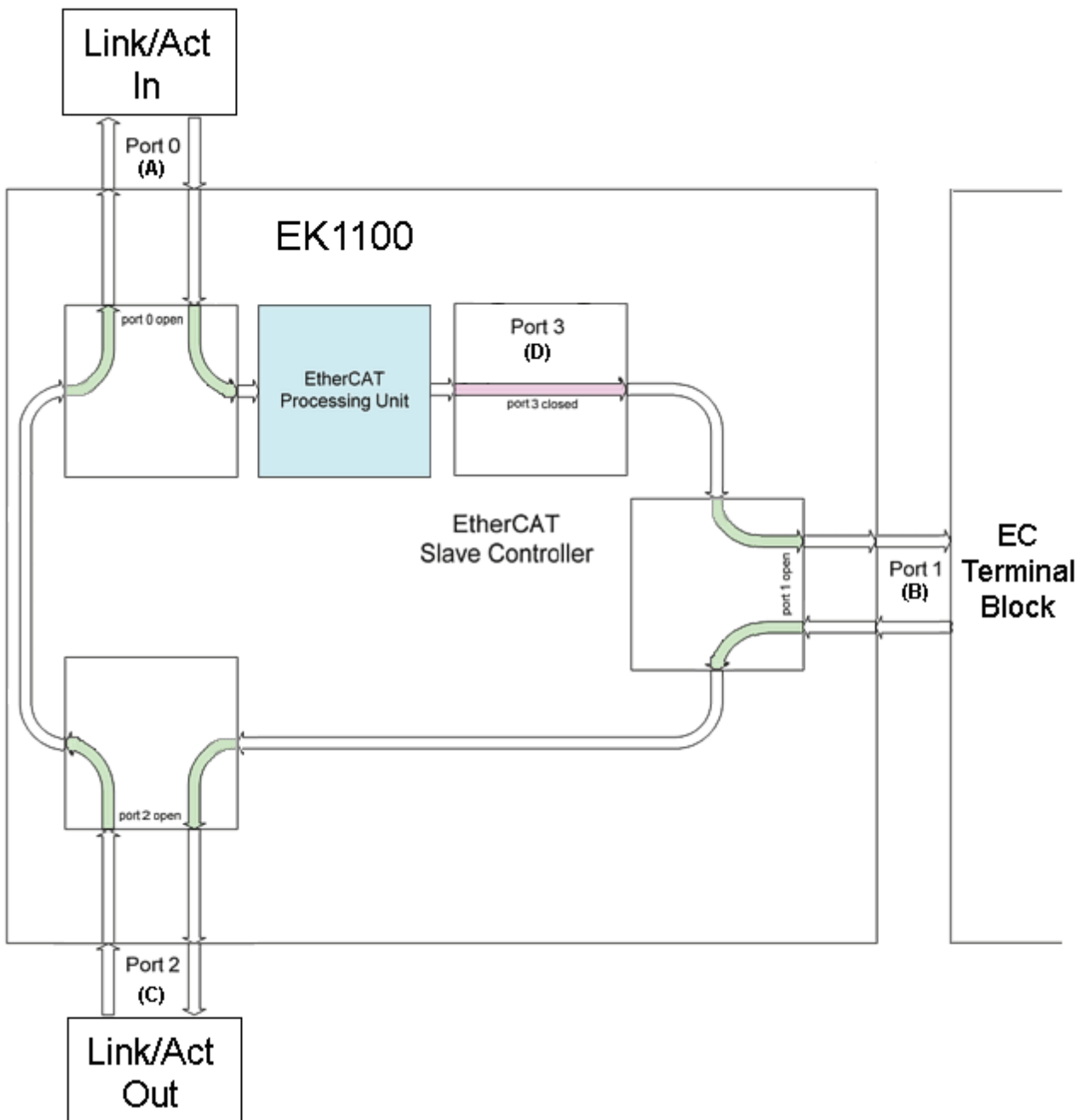

Fig. 17: Internal and external port assignment EK1100 Bus Coupler

Frame processing sequence

- The EtherCAT frame arriving at the EtherCAT signal input is passed on by Port 0 (A) to the EtherCAT processing unit.
- The EtherCAT frame arrives at Port 1 (B) and the data frame departs via Port 1 (B) to the following slave in the EtherCAT terminal network (if a slave is connected there and reports "Link").
- After the arrival of the data frame at Port 1 (B) from the terminal network, this is passed on to Port 2 (C) and leaves the coupler at the following EtherCAT output (if a slave is connected there and reports "Link").
- The data frame arrives at Port 2 (C). This is now passed on to Port 0 (A) and leaves the EK1100 via the EtherCAT input.

i **Processing of the data**

The data in the EtherCAT datagrams are processed only between Ports 0 (A) and 3 (D) in the EtherCAT processing unit. The non-implemented (internal) Port 3 (D) is considered to be closed and passes on the datagram to Port 1 (B).

5 Mounting and wiring

5.1 Instructions for ESD protection

NOTE

Destruction of the devices by electrostatic discharge possible!

The devices contain components at risk from electrostatic discharge caused by improper handling.

- Please ensure you are electrostatically discharged and avoid touching the contacts of the device directly.
- Avoid contact with highly insulating materials (synthetic fibers, plastic film etc.).
- Surroundings (working place, packaging and personnel) should be grounded probably, when handling with the devices.
- Each assembly must be terminated at the right hand end with an [EL9011](#) or [EL9012](#) bus end cap, to ensure the protection class and ESD protection.

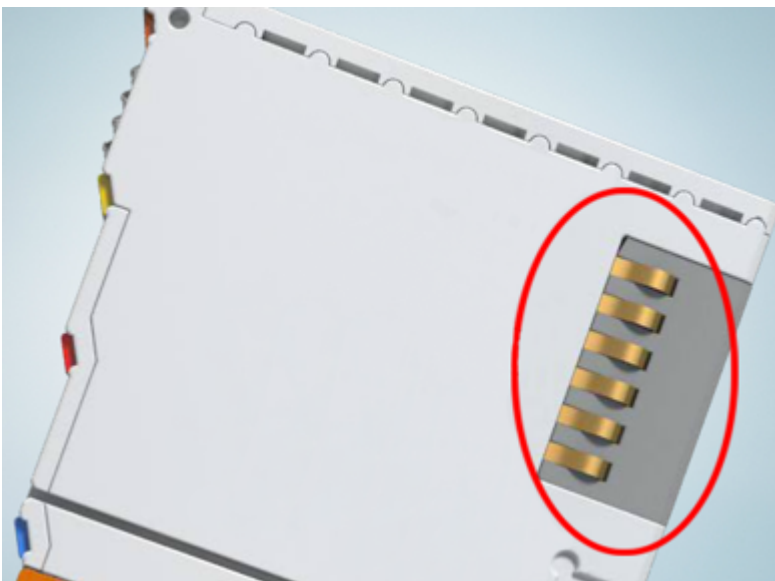

Fig. 18: Spring contacts of the Beckhoff I/O components

5.2 Installation on mounting rails

⚠ WARNING

Risk of electric shock and damage of device!

Bring the bus terminal system into a safe, powered down state before starting installation, disassembly or wiring of the bus terminals!

Assembly

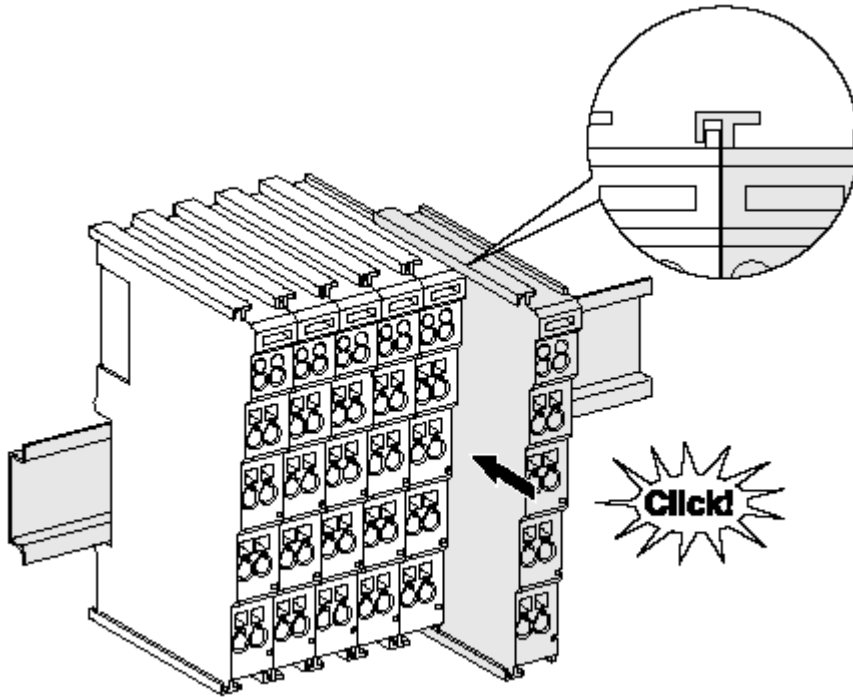

Fig. 19: Attaching on mounting rail

The bus coupler and bus terminals are attached to commercially available 35 mm mounting rails (DIN rails according to EN 60715) by applying slight pressure:

1. First attach the fieldbus coupler to the mounting rail.
2. The bus terminals are now attached on the right-hand side of the fieldbus coupler. Join the components with tongue and groove and push the terminals against the mounting rail, until the lock clicks onto the mounting rail.

If the terminals are clipped onto the mounting rail first and then pushed together without tongue and groove, the connection will not be operational! When correctly assembled, no significant gap should be visible between the housings.

i Fixing of mounting rails

The locking mechanism of the terminals and couplers extends to the profile of the mounting rail. At the installation, the locking mechanism of the components must not come into conflict with the fixing bolts of the mounting rail. To mount the mounting rails with a height of 7.5 mm under the terminals and couplers, you should use flat mounting connections (e.g. countersunk screws or blind rivets).

Disassembly

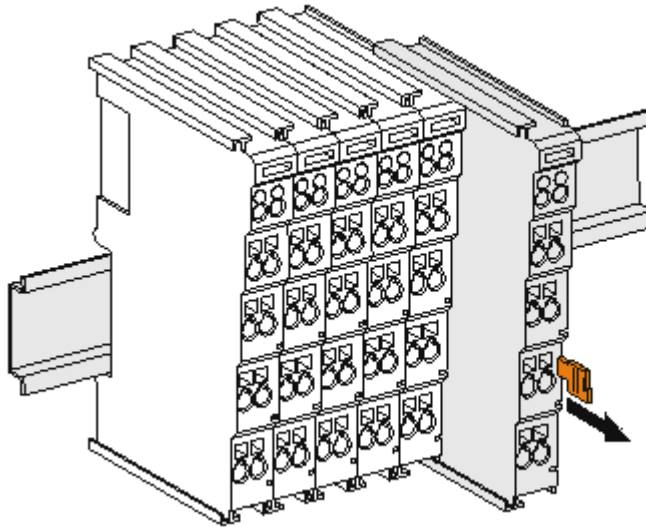

Fig. 20: Disassembling of terminal

Each terminal is secured by a lock on the mounting rail, which must be released for disassembly:

1. Pull the terminal by its orange-colored lugs approximately 1 cm away from the mounting rail. In doing so for this terminal the mounting rail lock is released automatically and you can pull the terminal out of the bus terminal block easily without excessive force.
2. Grasp the released terminal with thumb and index finger simultaneous at the upper and lower grooved housing surfaces and pull the terminal out of the bus terminal block.

Connections within a bus terminal block

The electric connections between the Bus Coupler and the Bus Terminals are automatically realized by joining the components:

- The six spring contacts of the K-Bus/E-Bus deal with the transfer of the data and the supply of the Bus Terminal electronics.
- The power contacts deal with the supply for the field electronics and thus represent a supply rail within the bus terminal block. The power contacts are supplied via terminals on the Bus Coupler (up to 24 V) or for higher voltages via power feed terminals.

i Power Contacts

During the design of a bus terminal block, the pin assignment of the individual Bus Terminals must be taken account of, since some types (e.g. analog Bus Terminals or digital 4-channel Bus Terminals) do not or not fully loop through the power contacts. Power Feed Terminals (KL91xx, KL92xx or EL91xx, EL92xx) interrupt the power contacts and thus represent the start of a new supply rail.

PE power contact

The power contact labeled PE can be used as a protective earth. For safety reasons this contact mates first when plugging together, and can ground short-circuit currents of up to 125 A.

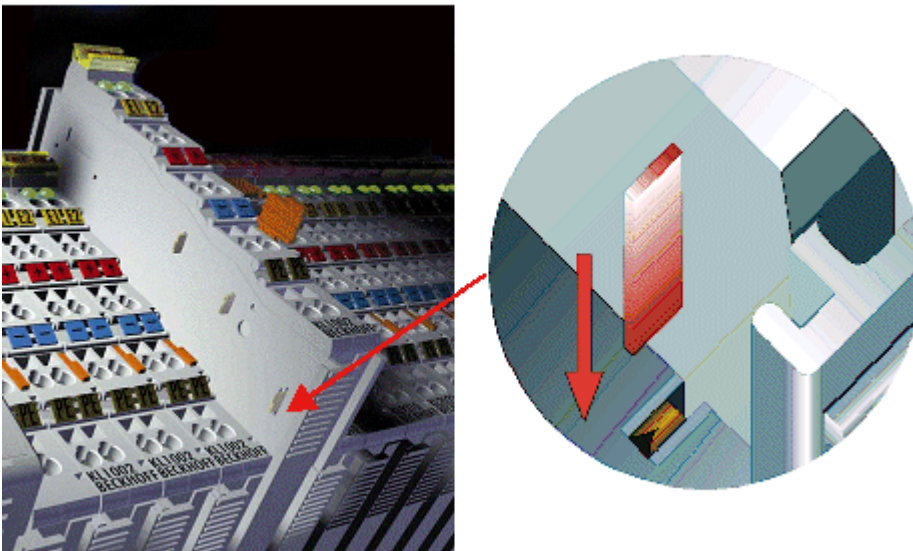

Fig. 21: Power contact on left side

NOTE**Possible damage of the device**

Note that, for reasons of electromagnetic compatibility, the PE contacts are capacitatively coupled to the mounting rail. This may lead to incorrect results during insulation testing or to damage on the terminal (e.g. disruptive discharge to the PE line during insulation testing of a consumer with a nominal voltage of 230 V). For insulation testing, disconnect the PE supply line at the Bus Coupler or the Power Feed Terminal! In order to decouple further feed points for testing, these Power Feed Terminals can be released and pulled at least 10 mm from the group of terminals.

⚠ WARNING**Risk of electric shock!**

The PE power contact must not be used for other potentials!

5.3 Connection system

⚠ WARNING**Risk of electric shock and damage of device!**

Bring the bus terminal system into a safe, powered down state before starting installation, disassembly or wiring of the Bus Terminals!

Overview

The Bus Terminal system offers different connection options for optimum adaptation to the respective application:

- The terminals of KLxxxx and ELxxxx series with standard wiring include electronics and connection level in a single enclosure.
- The terminals of KSxxxx and ESxxxx series feature a pluggable connection level and enable steady wiring while replacing.
- The High Density Terminals (HD Terminals) include electronics and connection level in a single enclosure and have advanced packaging density.

Standard wiring



Fig. 22: Standard wiring

The terminals of KLxxxx and ELxxxx series have been tried and tested for years. They feature integrated screwless spring force technology for fast and simple assembly.

Pluggable wiring

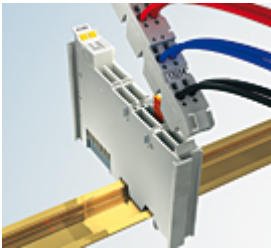

Fig. 23: Pluggable wiring

The terminals of KSxxxx and ESxxxx series feature a pluggable connection level. The assembly and wiring procedure for the KS series is the same as for the KLxxxx and ELxxxx series. The KS/ES series terminals enable the complete wiring to be removed as a plug connector from the top of the housing for servicing. The lower section can be removed from the terminal block by pulling the unlocking tab. Insert the new component and plug in the connector with the wiring. This reduces the installation time and eliminates the risk of wires being mixed up.

The familiar dimensions of the terminal only had to be changed slightly. The new connector adds about 3 mm. The maximum height of the terminal remains unchanged.

A tab for strain relief of the cable simplifies assembly in many applications and prevents tangling of individual connection wires when the connector is removed.

Conductor cross sections between 0.08 mm² and 2.5 mm² can continue to be used with the proven spring force technology.

The overview and nomenclature of the product names for KSxxxx and ESxxxx series has been retained as known from KLxxxx and ELxxxx series.

High Density Terminals (HD Terminals)



Fig. 24: *High Density Terminals*

The Bus Terminals from these series with 16 connection points are distinguished by a particularly compact design, as the packaging density is twice as large as that of the standard 12 mm Bus Terminals. Massive conductors and conductors with a wire end sleeve can be inserted directly into the spring loaded terminal point without tools.

Wiring HD Terminals

The High Density (HD) Terminals of the KLx8xx and ELx8xx series doesn't support steady wiring.

Ultrasonically "bonded" (ultrasonically welded) conductors

Ultrasonically "bonded" conductors

It is also possible to connect the Standard and High Density Terminals with ultrasonically "bonded" (ultrasonically welded) conductors. In this case, please note the tables concerning the wire-size width [► 32] below!

Wiring

Terminals for standard wiring ELxxxx/KLxxxx and for pluggable wiring ESxxxx/KSxxxx

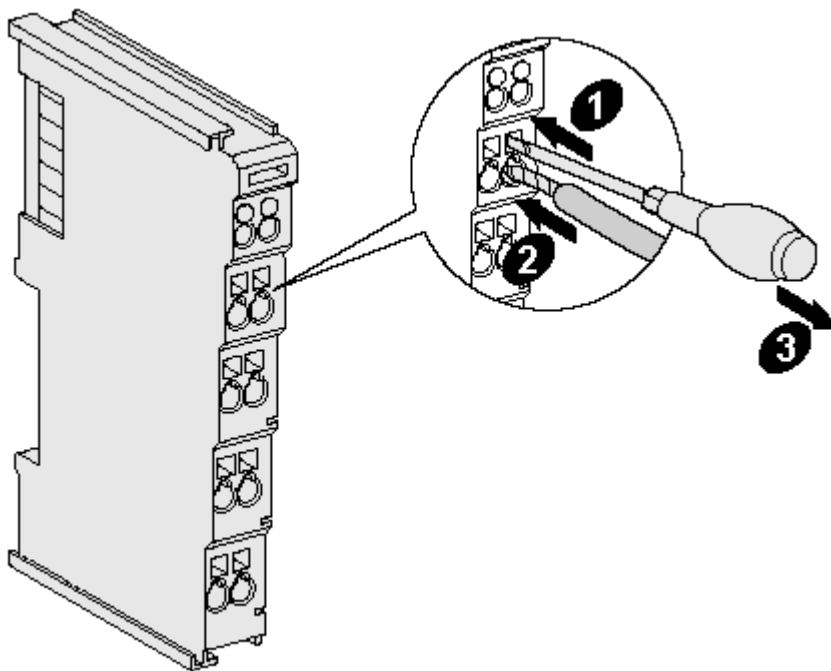

Fig. 25: Mounting a cable on a terminal connection

Up to eight connections enable the connection of solid or finely stranded cables to the Bus Terminals. The terminals are implemented in spring force technology. Connect the cables as follows:

1. Open a spring-loaded terminal by slightly pushing with a screwdriver or a rod into the square opening above the terminal.
2. The wire can now be inserted into the round terminal opening without any force.
3. The terminal closes automatically when the pressure is released, holding the wire securely and permanently.

Terminal housing	ELxxxx, KLxxxx	ESxxxx, KSxxxx
Wire size width	0.08 ... 2,5 mm ²	0.08 ... 2.5 mm ²
Wire stripping length	8 ... 9 mm	9 ... 10 mm

High Density Terminals ELx8xx, KLx8xx (HD)

The conductors of the HD Terminals are connected without tools for single-wire conductors using the direct plug-in technique, i.e. after stripping the wire is simply plugged into the contact point. The cables are released, as usual, using the contact release with the aid of a screwdriver. See the following table for the suitable wire size width.

Terminal housing	High Density Housing
Wire size width (conductors with a wire end sleeve)	0.14 ... 0.75 mm ²
Wire size width (single core wires)	0.08 ... 1.5 mm ²
Wire size width (fine-wire conductors)	0.25 ... 1.5 mm ²
Wire size width (ultrasonically "bonded" conductors)	only 1.5 mm ² (see notice [▶_32]!)
Wire stripping length	8 ... 9 mm

Shielding



Shielding

Analog sensors and actors should always be connected with shielded, twisted paired wires.

5.4 Positioning of passive Terminals

i **Hint for positioning of passive terminals in the bus terminal block**

EtherCAT Terminals (ELxxxx / ESxxxx), which do not take an active part in data transfer within the bus terminal block are so called passive terminals. The passive terminals have no current consumption out of the E-Bus.

To ensure an optimal data transfer, you must not directly string together more than 2 passive terminals!

Examples for positioning of passive terminals (highlighted)

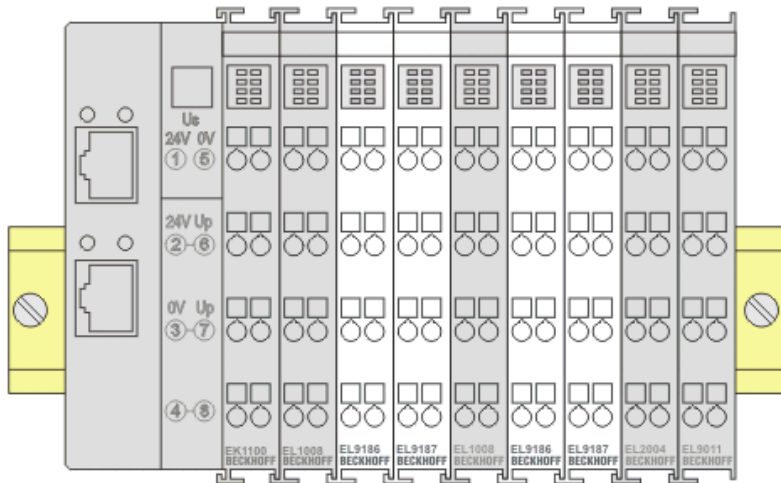

Fig. 26: Correct positioning

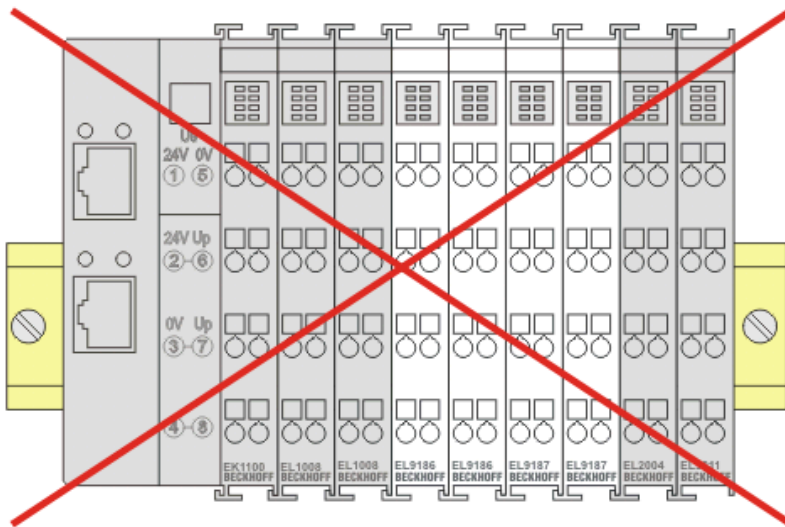

Fig. 27: Incorrect positioning

5.5 Power supply, potential groups

Bus Coupler power supply

The Bus Couplers require a 24 V_{DC} supply for their operation. The connection is made by means of the upper spring-loaded terminals labelled 24 V and 0 V. The supply voltage is used by the Bus Coupler electronics and for direct voltage generation for the E-bus. The voltage generation for the E-bus takes place in a DC/DC converter without electrical isolation.

NOTE

E-bus power supply

The EK18xx units supply the E-bus with max. 1000 mA E-bus current. Power feed terminals are to be inserted if the added terminals require more current!

Input for power contacts

The connections with spring-loaded terminals can be used for the peripheral supply. The spring-loaded terminals are linked with a power contact. The feed for the power contacts has no connection to the voltage supply for the Bus Coupler. The design of the feed permits voltages of up to 24 V. The current load via the power contacts may not permanently exceed 10 A; the supply line must therefore be protected by a 10 A fuse (slow-blow).

Power contacts

On the right hand face of the Bus Coupler there are two spring contacts for the power contact connections. The spring contacts are hidden in slots so that they can not be accidentally touched. By attaching a Bus Terminal the blade contacts on the left hand side of the Bus Terminal are connected to the spring contacts. The tongue and groove guides on the top and bottom of the Bus Coupler and of the Bus Terminals guarantees that the power contacts mate securely.

The current load of the power contacts may not permanently exceed 10 A.

Electrical isolation

The bus couplers operate by means of three independent potential groups. The supply voltage feeds the E-bus electronics in the bus coupler and the E-bus itself, which are electrically isolated. The supply voltage is also used to generate the operating voltage for the fieldbus.

Note: All the Bus Terminals are electrically isolated from the E-bus. The E-bus is thus electrically isolated from everything else.

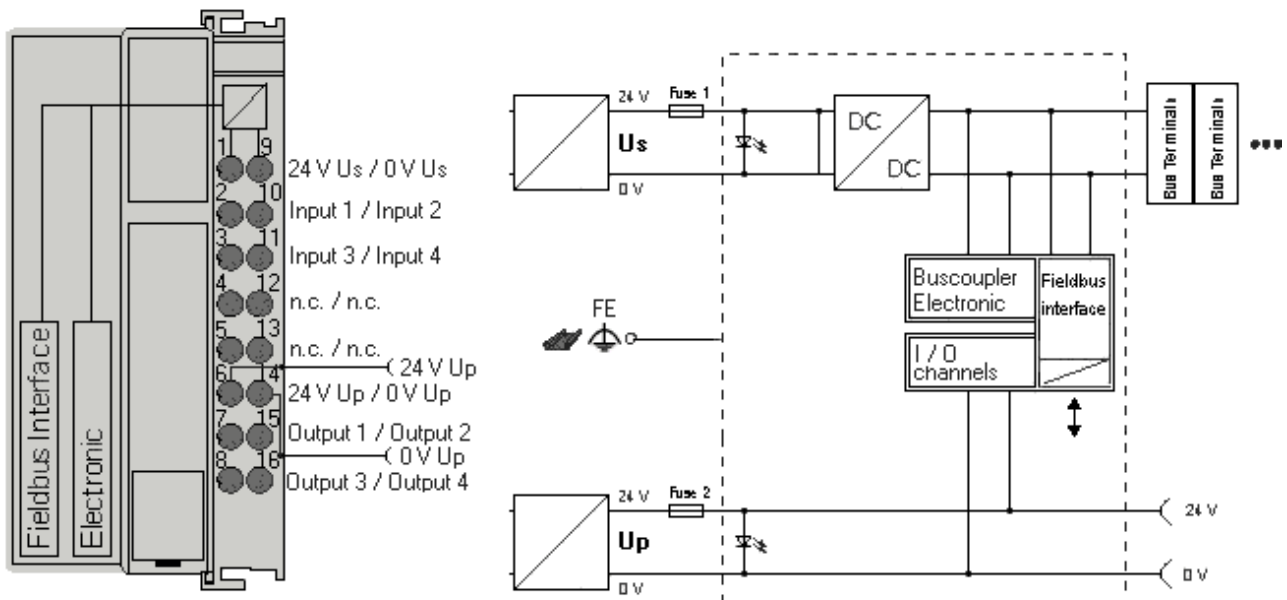

Fig. 28: Potential connection diagram (example EK1814)

GND concept

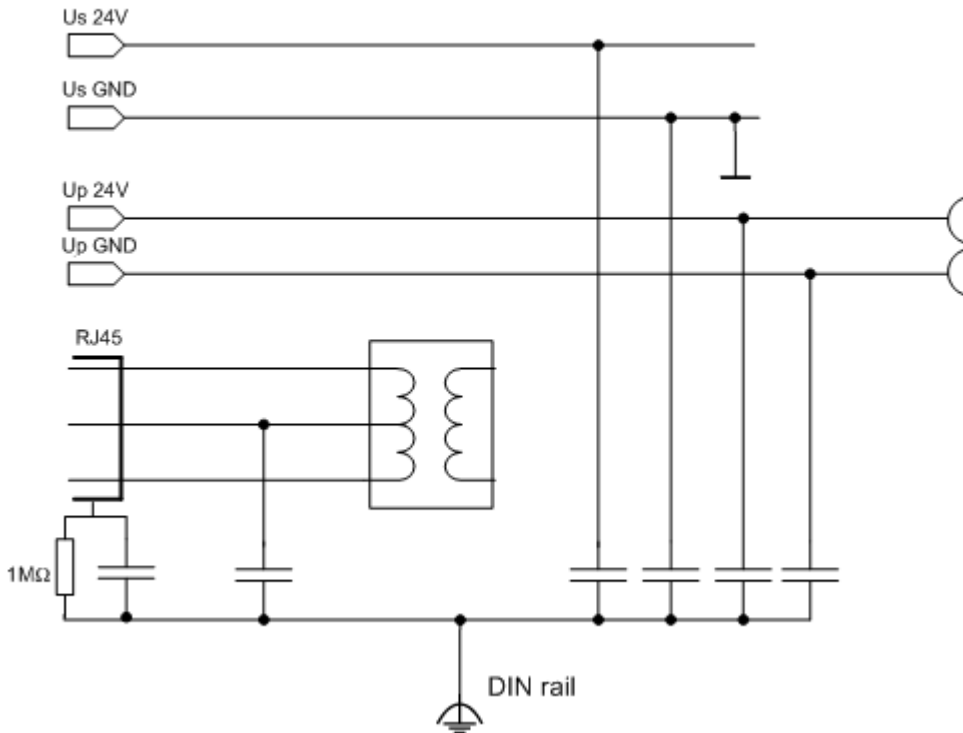

Fig. 29: GND concept EK18xx

Fuse protection

Coupler supply, fuse 1:

depending on the required current consumption and hence the configured terminals typ. max 500 mA

● Calculating the fuse protection

i For dimensioning the fuse protection for the system voltage note the calculation of current consumption [► 21] in the technical data!

Power contacts, fuse 2:

permitted max. 10 A (slow-blow)

Coupler electronics and power contacts can be supplied together from the same source; the fusing must then be dimensioned accordingly to max. 10 A.

5.6 EK18xx - connection

5.6.1 EK1814 - connection

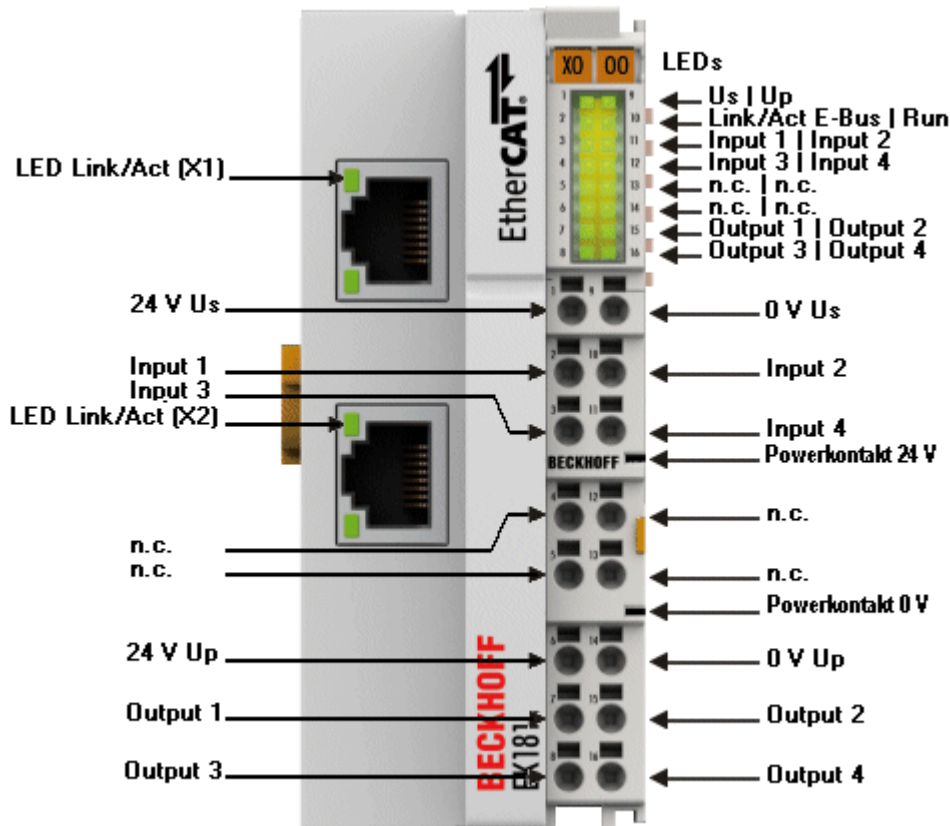

Fig. 30: Connection EK1814-0000

Connection

Terminal point		Description
Name	No.	
Us 24 V	1	Power supply for Bus Coupler and E-bus electronics
Input 1	2	Input channel 1
Input 3	3	Input channel 3
n.c.	4	not connected
n.c.	5	not connected
Up 24 V	6	Power supply for the power contacts
Output 1	7	Output channel 1
Output 3	8	Output channel 3
Us 0 V	9	Power supply for Bus Coupler and E-bus electronics
Input 2	10	Input channel 2
Input 4	11	Input channel 4
n.c.	12	not connected
n.c.	13	not connected
Up 0 V	14	Power supply for the power contacts
Output 2	15	Output channel 2
Output 4	16	Output channel 4

5.6.2 EK1818 - connection

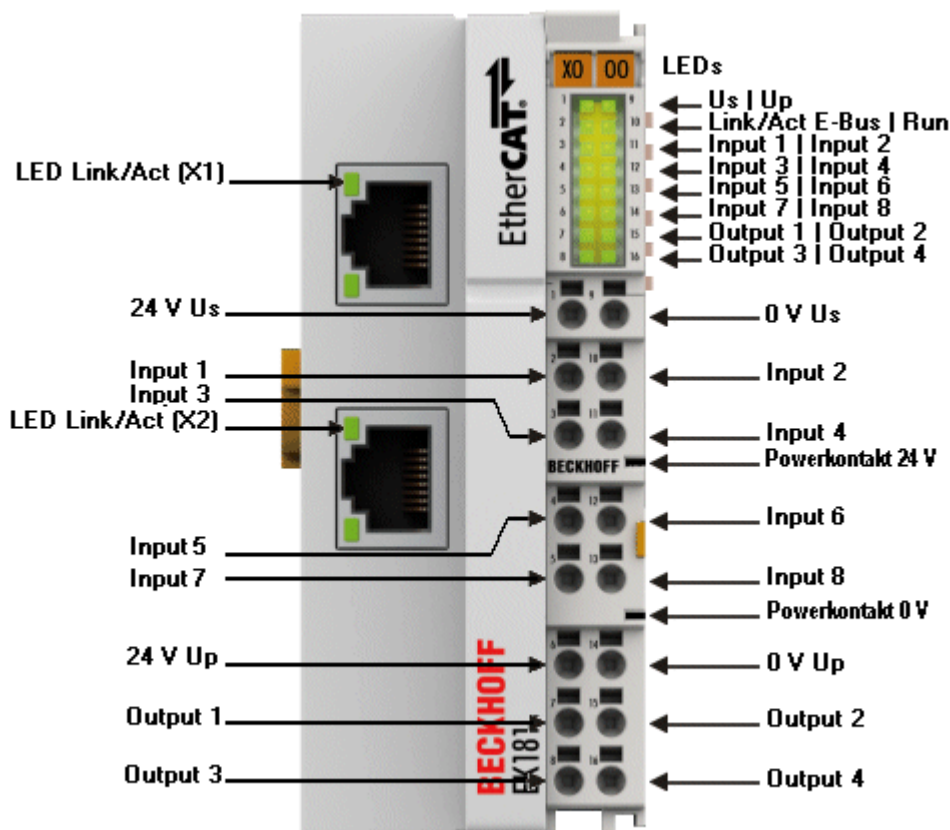

Fig. 31: Connection EK1818-0000

Connection

Terminal point		Description
Name	No.	
Us 24 V	1	Power supply for Bus Coupler and E-bus electronics
Input 1	2	Input channel 1
Input 3	3	Input channel 3
Input 5	4	Input channel 5
Input 7	5	Input channel 7
Up 24 V	6	Power supply for the power contacts
Output 1	7	Output channel 1
Output 3	8	Output channel 3
Us 0 V	9	Power supply for Bus Coupler and E-bus electronics
Input 2	10	Input channel 2
Input 4	11	Input channel 4
Input 6	12	Input channel 6
Input 8	13	Input channel 8
Up 0 V	14	Power supply for the power contacts
Output 2	15	Output channel 2
Output 4	16	Output channel 4

5.6.3 EK1828 - connection

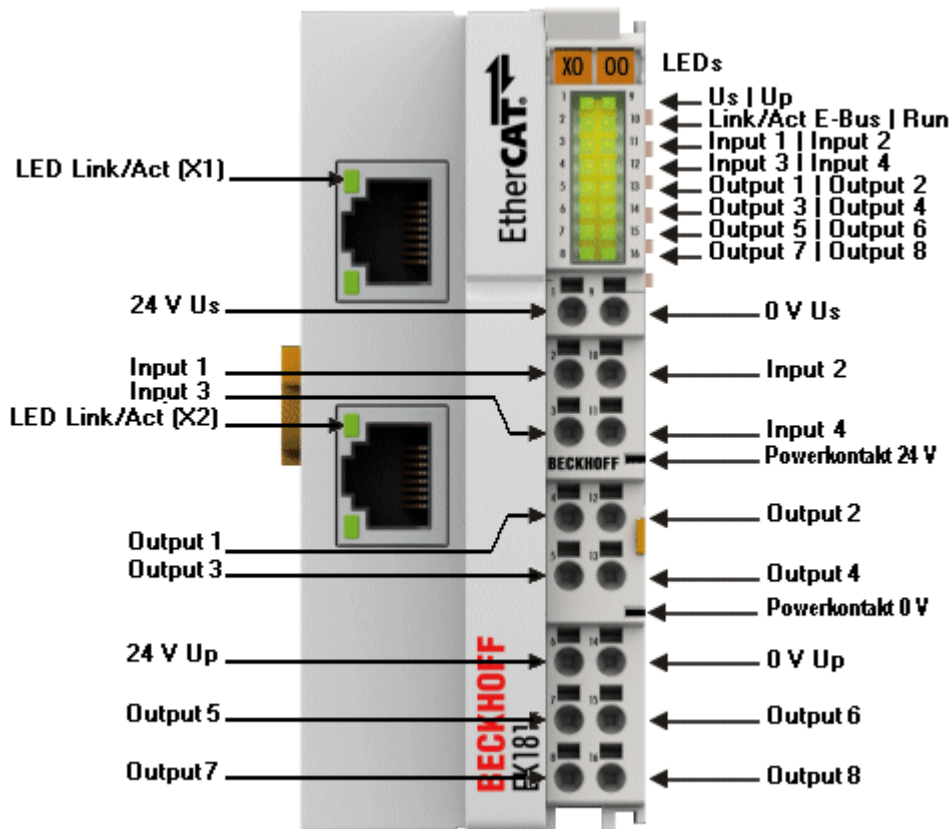

Fig. 32: Connection EK1828-0000

Connection

Terminal point		Description
Name	No.	
Us 24 V	1	Power supply for Bus Coupler and E-bus electronics
Input 1	2	Input channel 1
Input 3	3	Input channel 3
Output 1	4	Output channel 1
Output 3	5	Output channel 3
Up 24 V	6	Power supply for the power contacts
Output 5	7	Output channel 5
Output 7	8	Output channel 7
Us 0 V	9	Power supply for Bus Coupler and E-bus electronics
Input 2	10	Input channel 2
Input 4	11	Input channel 4
Output 2	12	Output channel 2
Output 4	13	Output channel 4
Up 0 V	14	Power supply for the power contacts
Output 6	15	Output channel 6
Output 8	16	Output channel 8

5.6.4 EK1828-0010 - connection

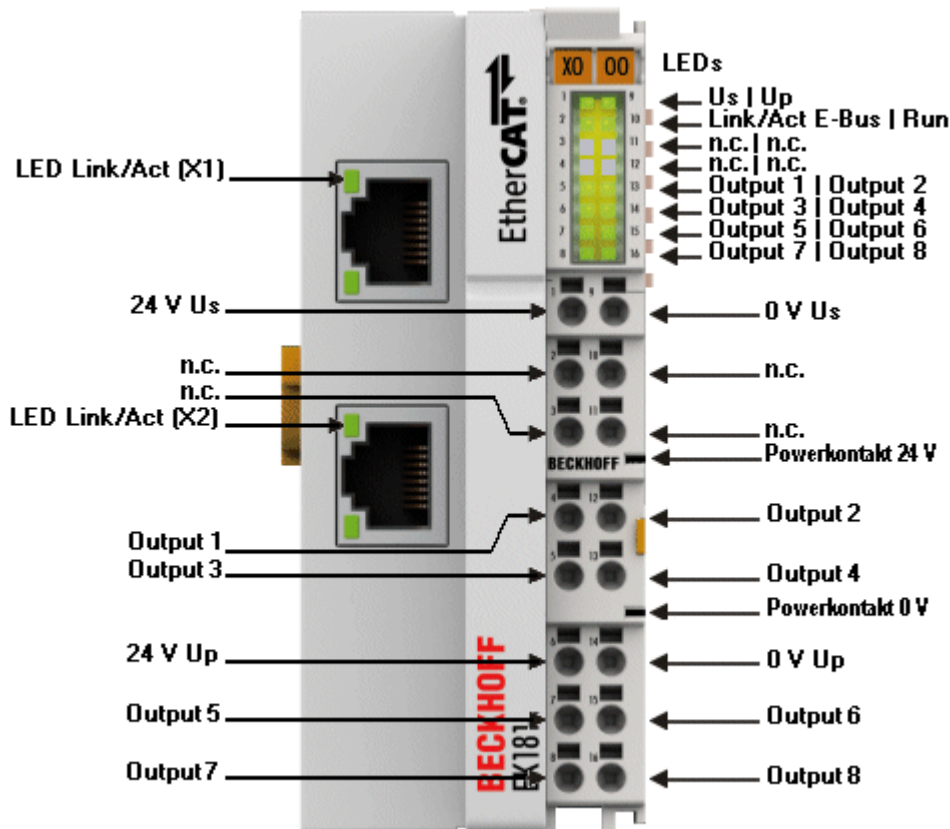

Fig. 33: Connection EK1828-0010

Connection

Terminal point		Description
Name	No.	
Us 24 V	1	Power supply for Bus Coupler and E-bus electronics
n.c.	2	not connected
n.c.	3	not connected
Output 1	4	Output channel 1
Output 3	5	Output channel 3
Up 24 V	6	Power supply for the power contacts
Output 5	7	Output channel 5
Output 7	8	Output channel 7
Us 0 V	9	Power supply for Bus Coupler and E-bus electronics
n.c.	10	not connected
n.c.	11	not connected
Output 2	12	Output channel 2
Output 4	13	Output channel 4
Up 0 V	14	Power supply for the power contacts
Output 6	15	Output channel 6
Output 8	16	Output channel 8

6 Parameterization and commissioning

6.1 Configuration overview

More detailed information on the configuration settings can be found in the [EtherCAT system documentation](#) on the Beckhoff website.

6.2 Overview of process data

In the TwinCAT System Manager, enter the EK18xx as an EtherCAT (Direct mode) device in Config mode under Devices. If the Bus Coupler is already connected to the network, it can be read. This will cause all the Bus Couplers with Bus Terminals and their configurations to be loaded. You can then adapt these to meet your requirements.

6.2.1 EK1814

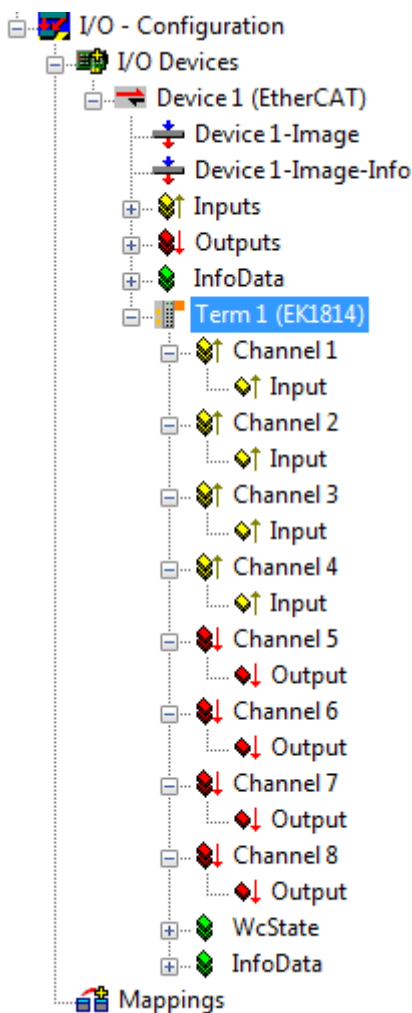

Fig. 34: TwinCAT tree EK1814

Extent of process data EK1814

General | **EtherCAT** | Process Data | Online

Sync Manager:

SM	Size	Type	Flags
0	1	Outputs	
1	1	Inputs	

PDO List:

Index	Size	Name	Flags	SM	SU
0x1A00	0.1	Channel 1	MF	1	0
0x1A01	0.1	Channel 2	MF	1	0
0x1A02	0.1	Channel 3	MF	1	0
0x1A03	0.1	Channel 4	MF	1	0
0x1608	0.1	Channel 5	MF	0	0
0x1609	0.1	Channel 6	MF	0	0
0x160A	0.1	Channel 7	MF	0	0
0x160B	0.1	Channel 8	MF	0	0

PDO Assignment (0x1C11):

- 0x1A00
- 0x1A01
- 0x1A02
- 0x1A03

Download

- PDO Assignment
- PDO Configuration

PDO Content (0x1A00):

Index	Size	Offs	Name	Type	Default (hex)
0x6000:01	0.1	0.0	Input	BOOL	
		0.1			

Predefined PDO Assignment: (none)

Load PDO info from device

Sync Unit Assignment...

Fig. 35: Extent of process data EK1814 TwinCAT

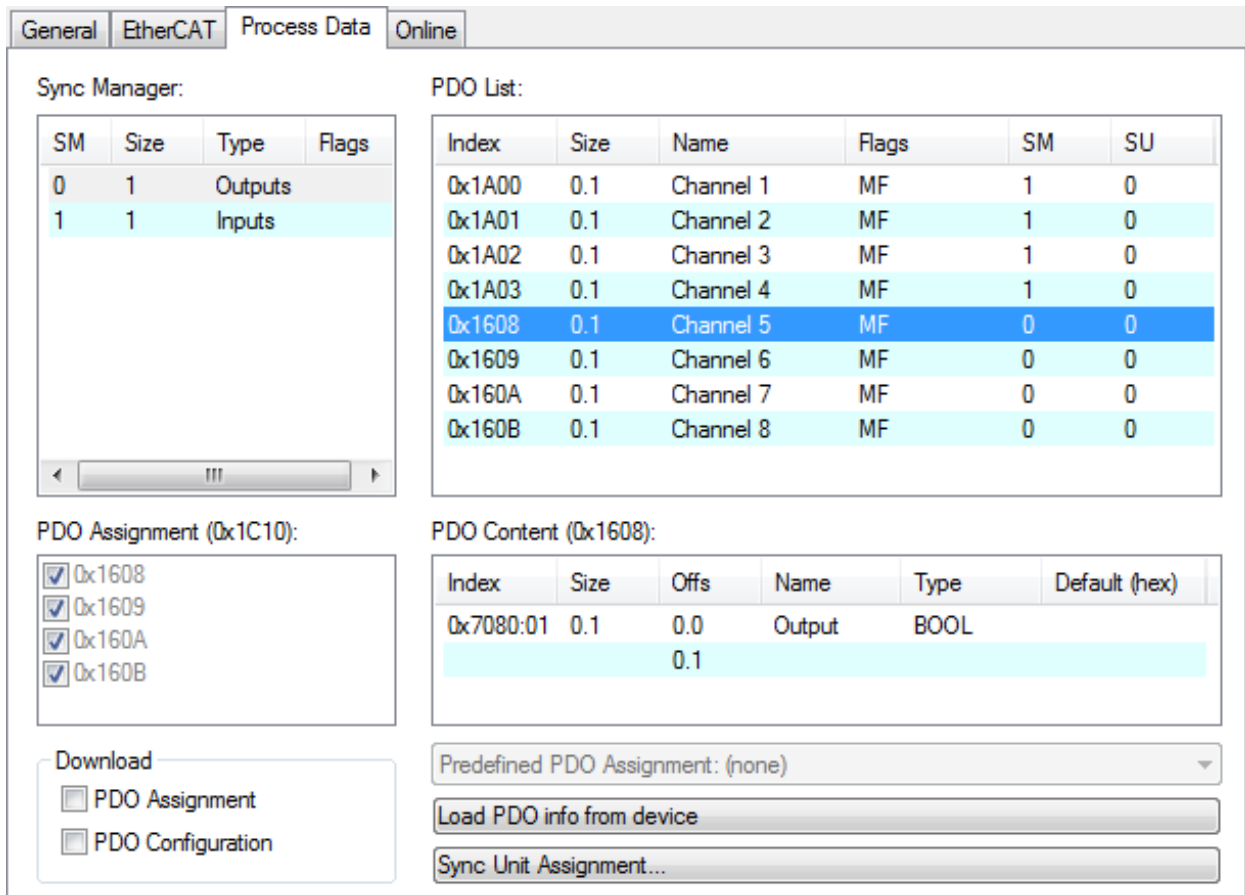

Fig. 36: Extent of process data EK1814 TwinCAT

PDO Assignment EK1814

SM1, PDO Assignment 0x1C11			
Index	Size (byte.bit)	Name	PDO content
0x1A00	0.1	Channel 1	Index 0x6000:01 - Input
0x1A01	0.1	Channel 2	Index 0x6010:01 - Input
0x1A02	0.1	Channel 3	Index 0x6020:01 - Input
0x1A03	0.1	Channel 4	Index 0x6030:01 - Input

SM0, PDO Assignment 0x1C10			
Index	Size (byte.bit)	Name	PDO content
0x1608	0.1	Channel 5	Index 0x7080:01 - Output
0x1609	0.1	Channel 6	Index 0x7090:01 - Output
0x160A	0.1	Channel 7	Index 0x70A0:01 - Output
0x160B	0.1	Channel 8	Index 0x70B0:01 - Output

Table 1 + 2: PDO assignment of the SyncManagers EK1814

6.2.2 EK1818

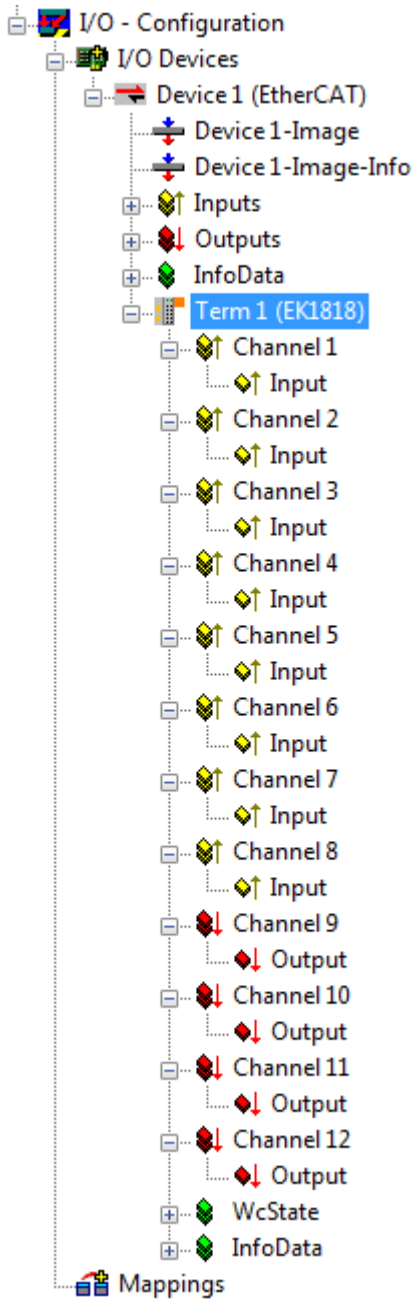

Fig. 37: TwinCAT tree EK1818

Extent of process data EK1818

General | EtherCAT | Process Data | Online

Sync Manager:

SM	Size	Type	Flags
0	1	Outputs	
1	1	Inputs	

PDO List:

Index	Size	Name	Flags	SM	SU
0x1A00	0.1	Channel 1	MF	1	0
0x1A01	0.1	Channel 2	MF	1	0
0x1A02	0.1	Channel 3	MF	1	0
0x1A03	0.1	Channel 4	MF	1	0
0x1A04	0.1	Channel 5	MF	1	0
0x1A05	0.1	Channel 6	MF	1	0
0x1A06	0.1	Channel 7	MF	1	0
0x1A07	0.1	Channel 8	MF	1	0
0x1600	0.1	Channel 9	MF	0	0
0x1601	0.1	Channel 10	MF	0	0
0x1602	0.1	Channel 11	MF	0	0
0x1603	0.1	Channel 12	MF	0	0

PDO Assignment (0x1C11):

- 0x1A00
- 0x1A01
- 0x1A02
- 0x1A03
- 0x1A04
- 0x1A05
- 0x1A06
- 0x1A07

Download

- PDO Assignment
- PDO Configuration

PDO Content (0x1A00):

Index	Size	Offs	Name	Type	Default (hex)
0x6000:01	0.1	0.0	Input	BOOL	
		0.1			

Predefined PDO Assignment: (none)

Load PDO info from device

Sync Unit Assignment...

Fig. 38: Extent of process data EK1818 TwinCAT

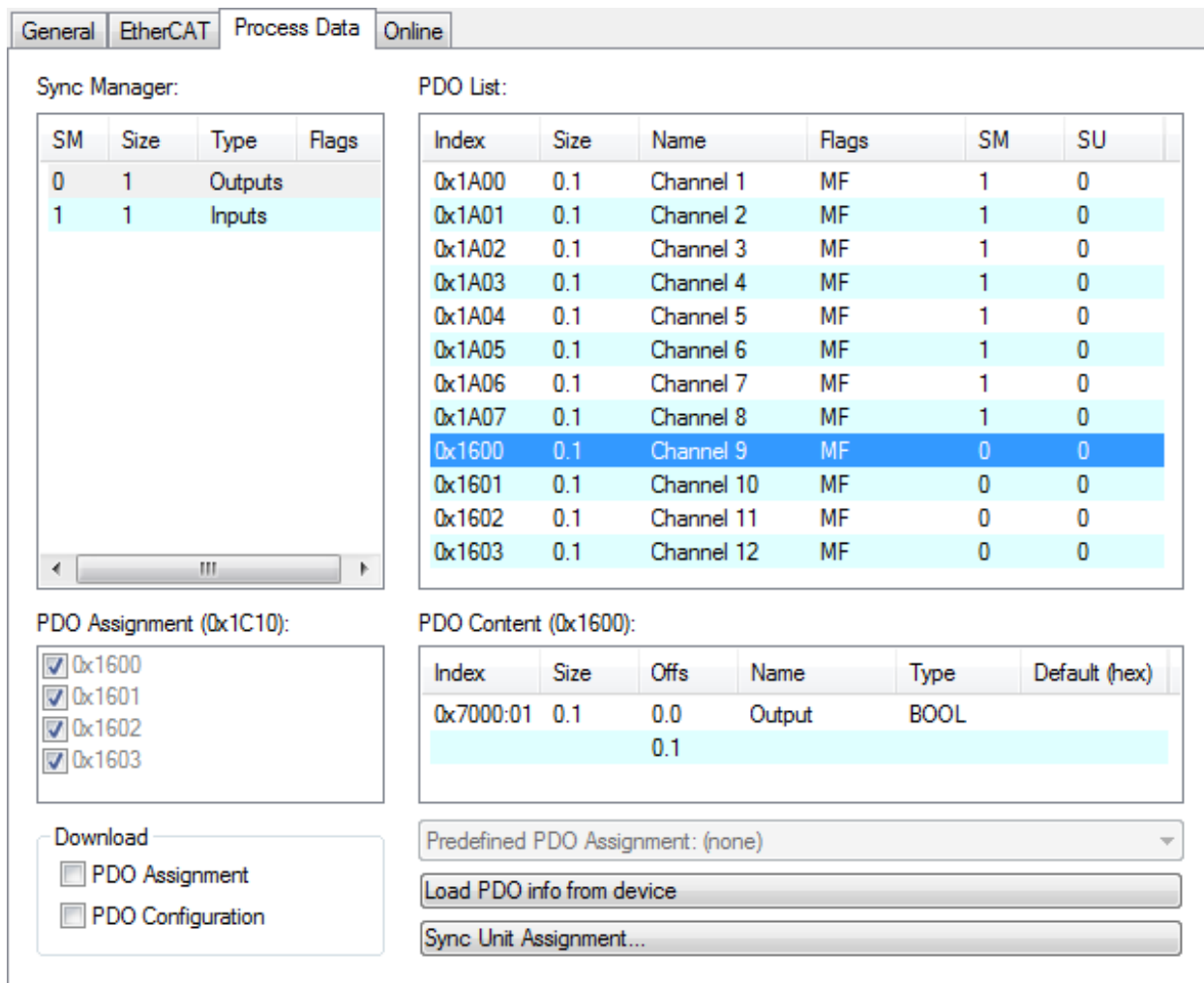

Fig. 39: Extent of process data EK1818 TwinCAT

PDO Assignment EK1818

SM1, PDO Assignment 0x1C11			
Index	Size (byte.bit)	Name	PDO content
0x1A00	0.1	Channel 1	Index 0x6000:01 - Input
0x1A01	0.1	Channel 2	Index 0x6010:01 - Input
0x1A02	0.1	Channel 3	Index 0x6020:01 - Input
0x1A03	0.1	Channel 4	Index 0x6030:01 - Input
0x1A04	0.1	Channel 5	Index 0x6040:01 - Input
0x1A05	0.1	Channel 6	Index 0x6050:01 - Input
0x1A06	0.1	Channel 7	Index 0x6060:01 - Input
0x1A07	0.1	Channel 8	Index 0x6070:01 - Input

SM0, PDO Assignment 0x1C10			
Index	Size (byte.bit)	Name	PDO content
0x1600	0.1	Channel 9	Index 0x7000:01 - Output
0x1601	0.1	Channel 10	Index 0x7010:01 - Output
0x1602	0.1	Channel 11	Index 0x7020:01 - Output
0x1603	0.1	Channel 12	Index 0x7030:01 - Output

Table 3 + 4: PDO assignment of the SyncManagers EK1818

6.2.3 EK1828

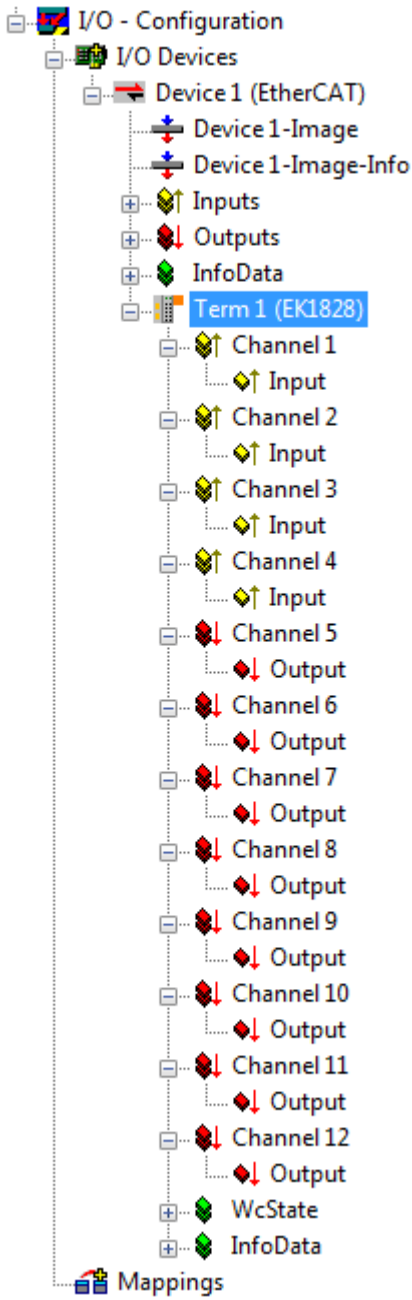

Fig. 40: TwinCAT tree EK1828

Extent of process data EK1828

General **EtherCAT** Process Data Online

Sync Manager:

SM	Size	Type	Flags
0	1	Outputs	
1	1	Outputs	
2	1	Inputs	

PDO List:

Index	Size	Name	Flags	SM	SU
0x1A00	0.1	Channel 1	MF	2	0
0x1A01	0.1	Channel 2	MF	2	0
0x1A02	0.1	Channel 3	MF	2	0
0x1A03	0.5	Channel 4	MF	2	0
0x1600	0.5	Channel 5	MF	0	0
0x1601	0.1	Channel 6	MF	0	0
0x1602	0.1	Channel 7	MF	0	0
0x1603	0.1	Channel 8	MF	0	0
0x1604	0.1	Channel 9	MF	1	0
0x1605	0.1	Channel 10	MF	1	0
0x1606	0.1	Channel 11	MF	1	0
0x1607	0.5	Channel 12	MF	1	0

PDO Assignment (0x1C12):

- 0x1A00
- 0x1A01
- 0x1A02
- 0x1A03

Download

- PDO Assignment
- PDO Configuration

PDO Content (0x1A00):

Index	Size	Offs	Name	Type
0x6000:01	0.1	0.0	Input	BOOL
		0.1		

Predefined PDO Assignment: (none)

Load PDO info from device

Sync Unit Assignment...

Fig. 41: Extent of process data EK1828 TwinCAT

General | **EtherCAT** | Process Data | Online

Sync Manager:

SM	Size	Type	Flags
0	1	Outputs	
1	1	Outputs	
2	1	Inputs	

PDO List:

Index	Size	Name	Flags	SM	SU
0x1A00	0.1	Channel 1	MF	2	0
0x1A01	0.1	Channel 2	MF	2	0
0x1A02	0.1	Channel 3	MF	2	0
0x1A03	0.5	Channel 4	MF	2	0
0x1600	0.5	Channel 5	MF	0	0
0x1601	0.1	Channel 6	MF	0	0
0x1602	0.1	Channel 7	MF	0	0
0x1603	0.1	Channel 8	MF	0	0
0x1604	0.1	Channel 9	MF	1	0
0x1605	0.1	Channel 10	MF	1	0
0x1606	0.1	Channel 11	MF	1	0
0x1607	0.5	Channel 12	MF	1	0

PDO Assignment (0x1C10):

- 0x1600
- 0x1601
- 0x1602
- 0x1603
- 0x1604
- 0x1605
- 0x1606
- 0x1607

Download

PDO Assignment

PDO Configuration

PDO Content (0x1600):

Index	Size	Offs	Name	Type
--	0.4	0.0	--	
0x7000:01	0.1	0.4	Output	BOOL
		0.5		

Predefined PDO Assignment: (none)

Load PDO info from device

Sync Unit Assignment...

Fig. 42: Extent of process data EK1828 TwinCAT

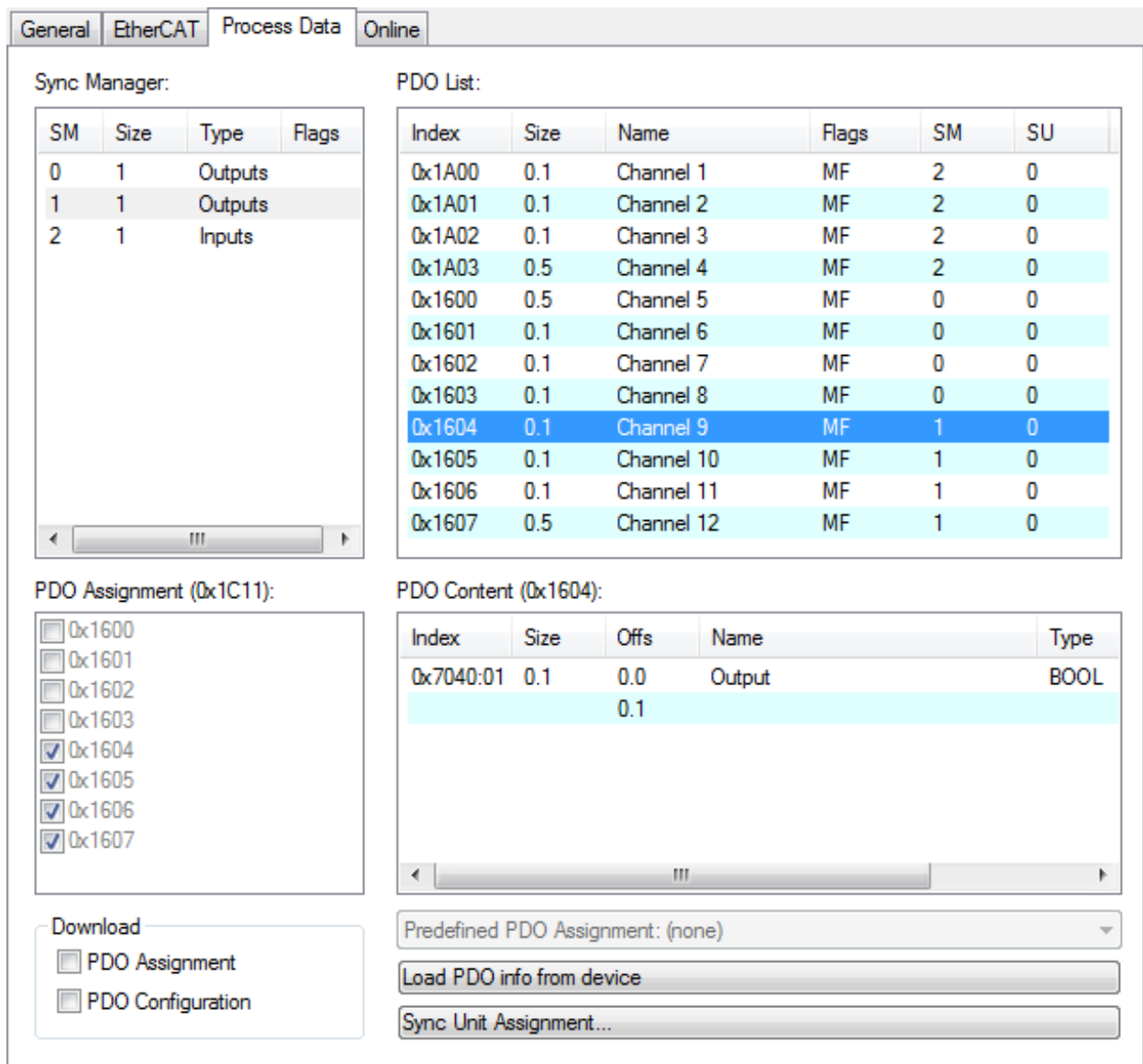

Fig. 43: Extent of process data EK1828 TwinCAT

PDO Assignment EK1828

SM2, PDO assignment 0x1C12			
Index	Size (byte.bit)	Name	PDO content
0x1A00	0.1	Channel 1	Index 0x6000:01 - Input
0x1A01	0.1	Channel 2	Index 0x6010:01 - Input
0x1A02	0.1	Channel 3	Index 0x6020:01 - Input
0x1A03	0.1	Channel 4	Index 0x6030:01 - Input

SM0, PDO Assignment 0x1C10			
Index	Size (byte.bit)	Name	PDO content
0x1600	0.1	Channel 5	Index 0x7000:01 - Output
0x1601	0.1	Channel 6	Index 0x7010:01 - Output
0x1602	0.1	Channel 7	Index 0x7020:01 - Output
0x1603	0.1	Channel 8	Index 0x7030:01 - Output

SM1, PDO Assignment 0x1C11			
Index	Size (byte.bit)	Name	PDO content
0x1604	0.1	Channel 9	Index 0x7040:01 - Output
0x1605	0.1	Channel 10	Index 0x7050:01 - Output
0x1606	0.1	Channel 11	Index 0x7060:01 - Output
0x1607	0.1	Channel 12	Index 0x7070:01 - Output

Table 5 + 6 + 7: Sync Manager PDO assignment EK1828

6.2.4 EK1828-0010

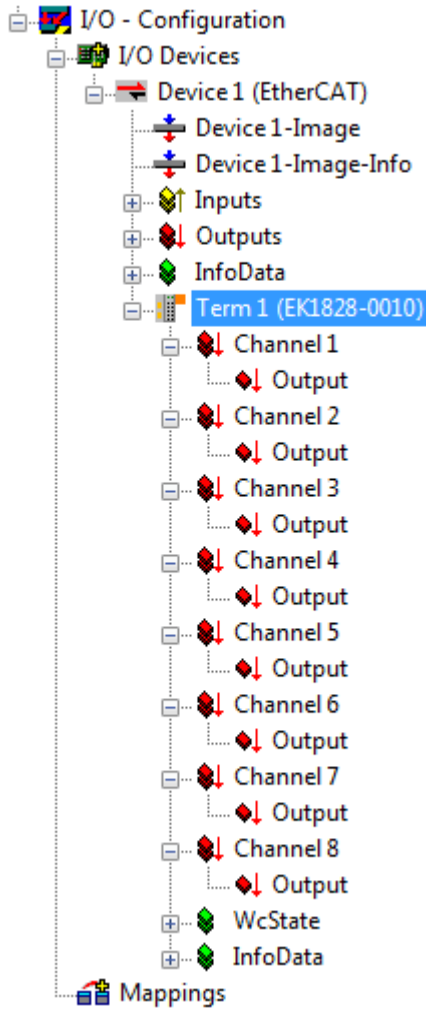

Fig. 44: TwinCAT tree EK1828-0010

Extent of process data EK1828-0010

General | **EtherCAT** | Process Data | Online

Sync Manager:

SM	Size	Type	Flags
0	1	Outputs	
1	1	Outputs	

PDO List:

Index	Size	Name	Flags	S
0x1600	0.5	Channel 1	MF	0
0x1601	0.1	Channel 2	MF	0
0x1602	0.1	Channel 3	MF	0
0x1603	0.1	Channel 4	MF	0
0x1604	0.1	Channel 5	MF	1
0x1605	0.1	Channel 6	MF	1
0x1606	0.1	Channel 7	MF	1
0x1607	0.5	Channel 8	MF	1

PDO Assignment (0x1C10):

- 0x1600
- 0x1601
- 0x1602
- 0x1603
- 0x1604
- 0x1605
- 0x1606
- 0x1607

PDO Content (0x1600):

Index	Size	Offs	Name	Type
--	0.4	0.0	--	
0x7000:01	0.1	0.4	Output	BOOL
		0.5		

Download

- PDO Assignment
- PDO Configuration

Predefined PDO Assignment: (none)

Load PDO info from device

Sync Unit Assignment...

Fig. 45: Extent of process data EK1828-0010 TwinCAT

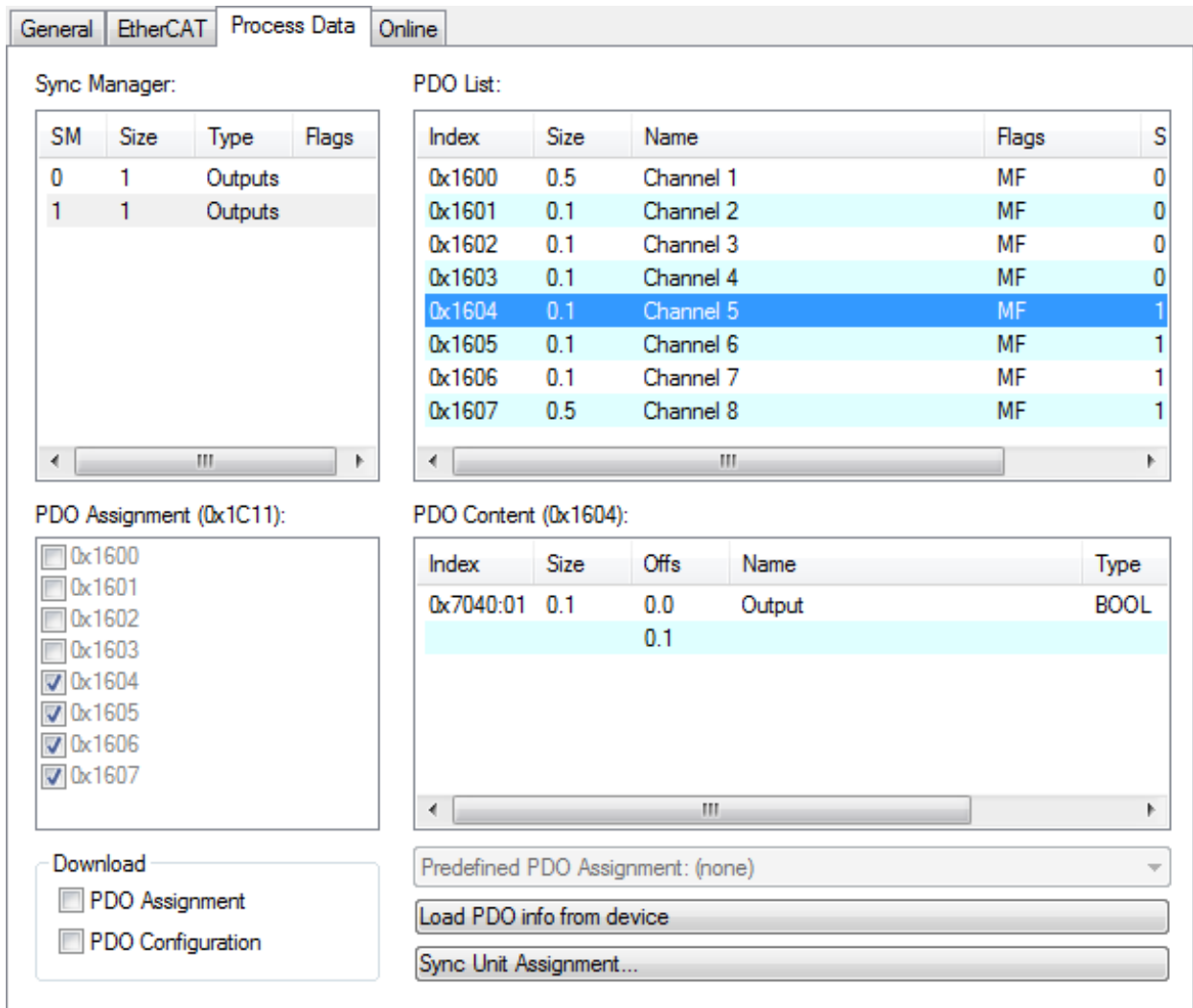

Fig. 46: Extent of process data EK1828-0010 TwinCAT

PDO Assignment EK1828-0010

SM0, PDO Assignment 0x1C10			
Index	Size (byte.bit)	Name	PDO content
0x1600	0.1	Channel 1	Index 0x7000:01 - Output
0x1601	0.1	Channel 2	Index 0x7010:01 - Output
0x1602	0.1	Channel 3	Index 0x7020:01 - Output
0x1603	0.1	Channel 4	Index 0x7030:01 - Output

SM1, PDO Assignment 0x1C11			
Index	Size (byte.bit)	Name	PDO content
0x1604	0.1	Channel 5	Index 0x7040:01 - Output
0x1605	0.1	Channel 6	Index 0x7050:01 - Output
0x1606	0.1	Channel 7	Index 0x7060:01 - Output
0x1607	0.1	Channel 8	Index 0x7070:01 - Output

Table 8 + 9 + 10: PDO assignment of the SyncManagers EK1828-0010

7 Error handling and diagnostics

7.1 Diagnostic LEDs

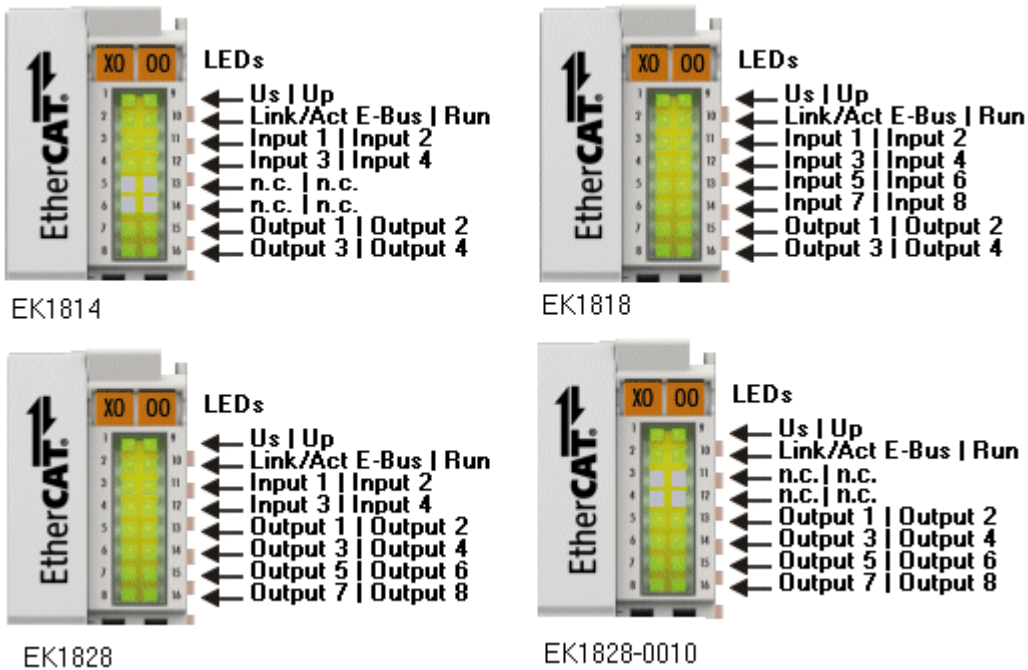

Fig. 47: Diagnostic LEDs

LEDs for power supply diagnostics

LED	Display	State	Description
Us	green	off	No operating voltage present at the Bus Coupler
		on	24 V _{DC} operating voltage present at the Bus Coupler
Up	green	off	No power supply present at the power contacts
		on	24 V _{DC} power supply present at the power contacts

Diagnostic LEDs for the EtherCAT State Machine/PLC

LED	Display	State	Description
RUN	green	off	Init The Bus Coupler is in initialization state
		flashing	Pre-Operational The Bus Coupler is in <i>pre-operational</i> state
		single flash	Safe-Operational The Bus Coupler is in <i>safe-operational</i> state
		on	Operational The Bus Coupler is in <i>operational</i> state
		flickers	Bootstrap Firmware is being loaded.

LEDs for fieldbus diagnostics

LED		Display	State	Description
LINK / ACT (X1 IN)	green	off	-	No connection on the incoming EtherCAT strand
		on	linked	Preceding EtherCAT device connected
		flashing	active	Communication with preceding EtherCAT device
LINK / ACT (X2 OUT)	green	off	-	No connection on the incoming EtherCAT strand
		on	linked	Following EtherCAT device connected
		flashing	active	Communication with following EtherCAT device
LINK / ACT E-bus	green	off	-	no connection to internal E-bus
		on	linked	Connection to internal E-bus
		flashing	active	Connection/communication internal E-bus



LEDs for diagnostics of the digital inputs and outputs

LED		Display	Description
INPUT**	green	off	Signal voltage "0" (-3 V ... 5 V)
		on	Signal voltage "1" (11 V ... 30 V)
OUTPUT**	green	off	No output signal
		on	24 V _{DC} output signal at the respective output

**) depending on version

8 Appendix

8.1 UL notice

	<p>Application Beckhoff EtherCAT modules are intended for use with Beckhoff's UL Listed EtherCAT System only.</p>
	<p>Examination For cULus examination, the Beckhoff I/O System has only been investigated for risk of fire and electrical shock (in accordance with UL508 and CSA C22.2 No. 142).</p>
	<p>For devices with Ethernet connectors Not for connection to telecommunication circuits.</p>

Basic principles

Two UL certificates are met in the Beckhoff EtherCAT product range, depending upon the components:

1. UL certification according to UL508. Devices with this kind of certification are marked by this sign:



2. UL certification according to UL508 with limited power consumption. The current consumed by the device is limited to a max. possible current consumption of 4 A. Devices with this kind of certification are marked by this sign:

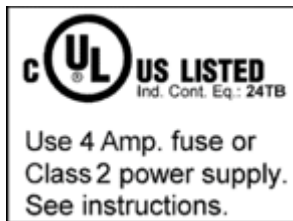

Almost all current EtherCAT products (as at 2010/05) are UL certified without restrictions.

Application

If terminals certified *with restrictions* are used, then the current consumption at 24 V_{DC} must be limited accordingly by means of supply

- from an isolated source protected by a fuse of max. 4 A (according to UL248) or
- from a voltage supply complying with *NEC class 2*.
A voltage source complying with *NEC class 2* may not be connected in series or parallel with another *NEC class 2* compliant voltage supply!

These requirements apply to the supply of all EtherCAT bus couplers, power adaptor terminals, Bus Terminals and their power contacts.

8.2 Firmware compatibility

The EK18xx couplers have no firmware.

An update of the XML device description is described in chapter "[Updating the device description \[▶ 58\]](#)", depending on the hardware version and the revision number shown below.

NOTE

Malfunction possible!

Note the information regarding XML update on the [separate page \[▶ 58\]](#).
Ensure that the XML device description is suitable for the hardware version of the device!

EK1814	
Hardware (HW)	Revision no..
00	EK1814-0000-0016
01	EK1814-0000-0017
02	
03	EK1814-0000-0018
04	
05	
06	EK1814-0000-0019*
07	
08	
09*	

EK1818	
Hardware (HW)	Revision no..
00	EK1818-0000-0016
01	
02	
03	EK1818-0000-0017
04	
05	
06	EK1818-0000-0018*
07	
08	
09*	

EK1828	
Hardware (HW)	Revision no..
02	EK1828-0000-0017
03	
04	
05	
06*	EK1828-0000-0018*

EK1828-0010	
Hardware (HW)	Revision no..
02	EK1828-0010-0017
03	
04	
05	EK1828-0010-0018*
06*	

*) This is the current compatible revision/hardware version at the time of the preparing this documentation. Check on the Beckhoff web page whether more up-to-date [documentation](#) is available.

8.3 Firmware Update EL/ES/EM/ELM/EPxxxx

This section describes the device update for Beckhoff EtherCAT slaves from the EL/ES, ELM, EM, EK and EP series. A firmware update should only be carried out after consultation with Beckhoff support.

Storage locations

An EtherCAT slave stores operating data in up to 3 locations:

- Depending on functionality and performance EtherCAT slaves have one or several local controllers for processing I/O data. The corresponding program is the so-called **firmware** in *.efw format.
- In some EtherCAT slaves the EtherCAT communication may also be integrated in these controllers. In this case the controller is usually a so-called **FPGA** chip with *.rbf firmware.
- In addition, each EtherCAT slave has a memory chip, a so-called **ESI-EEPROM**, for storing its own device description (ESI: EtherCAT Slave Information). On power-up this description is loaded and the EtherCAT communication is set up accordingly. The device description is available from the download area of the Beckhoff website at (<https://www.beckhoff.de>). All ESI files are accessible there as zip files.

Customers can access the data via the EtherCAT fieldbus and its communication mechanisms. Acyclic mailbox communication or register access to the ESC is used for updating or reading of these data.

The TwinCAT System Manager offers mechanisms for programming all 3 parts with new data, if the slave is set up for this purpose. Generally the slave does not check whether the new data are suitable, i.e. it may no longer be able to operate if the data are unsuitable.

Simplified update by bundle firmware

The update using so-called **bundle firmware** is more convenient: in this case the controller firmware and the ESI description are combined in a *.efw file; during the update both the firmware and the ESI are changed in the terminal. For this to happen it is necessary

- for the firmware to be in a packed format: recognizable by the file name, which also contains the revision number, e.g. ELxxx-xxx_REV0016_SW01.efw
- for password=1 to be entered in the download dialog. If password=0 (default setting) only the firmware update is carried out, without an ESI update.
- for the device to support this function. The function usually cannot be retrofitted; it is a component of many new developments from year of manufacture 2016.

Following the update, its success should be verified

- ESI/Revision: e.g. by means of an online scan in TwinCAT ConfigMode/FreeRun – this is a convenient way to determine the revision
- Firmware: e.g. by looking in the online CoE of the device

NOTE

Risk of damage to the device!

Note the following when downloading new device files

- Firmware downloads to an EtherCAT device must not be interrupted
- Flawless EtherCAT communication must be ensured. CRC errors or LostFrames must be avoided.
- The power supply must adequately dimensioned. The signal level must meet the specification.

In the event of malfunctions during the update process the EtherCAT device may become unusable and require re-commissioning by the manufacturer.

8.3.1 Device description ESI file/XML

NOTE

Attention regarding update of the ESI description/EEPROM

Some slaves have stored calibration and configuration data from the production in the EEPROM. These are irretrievably overwritten during an update.

The ESI device description is stored locally on the slave and loaded on start-up. Each device description has a unique identifier consisting of slave name (9 characters/digits) and a revision number (4 digits). Each slave configured in the System Manager shows its identifier in the EtherCAT tab:

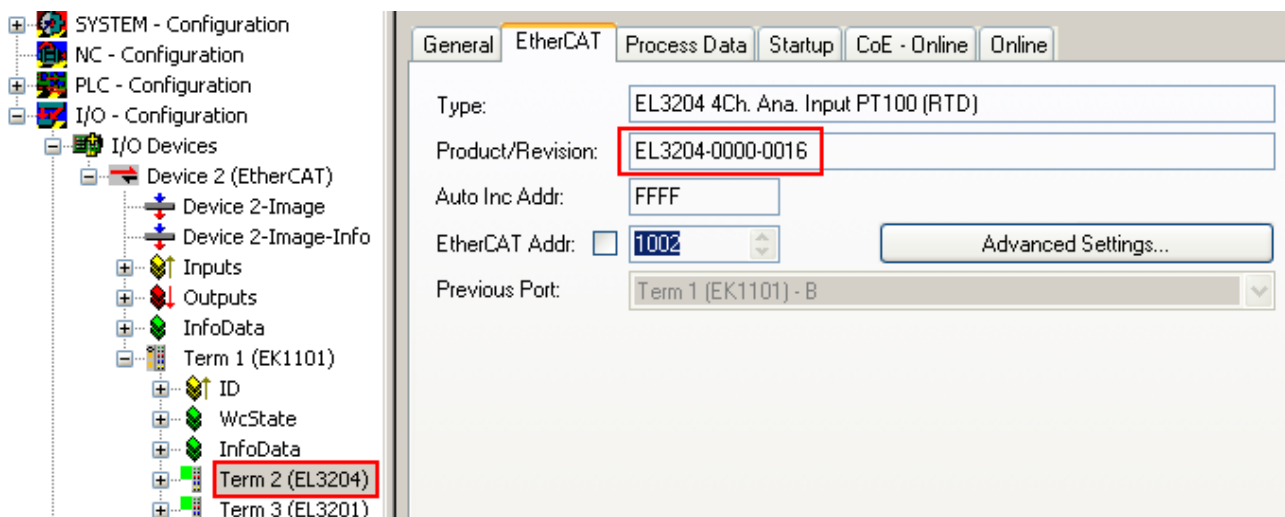

Fig. 48: Device identifier consisting of name EL3204-0000 and revision -0016

The configured identifier must be compatible with the actual device description used as hardware, i.e. the description which the slave has loaded on start-up (in this case EL3204). Normally the configured revision must be the same or lower than that actually present in the terminal network.

For further information on this, please refer to the [EtherCAT system documentation](#).

Update of XML/ESI description

The device revision is closely linked to the firmware and hardware used. Incompatible combinations lead to malfunctions or even final shutdown of the device. Corresponding updates should only be carried out in consultation with Beckhoff support.

Display of ESI slave identifier

The simplest way to ascertain compliance of configured and actual device description is to scan the EtherCAT boxes in TwinCAT mode Config/FreeRun:

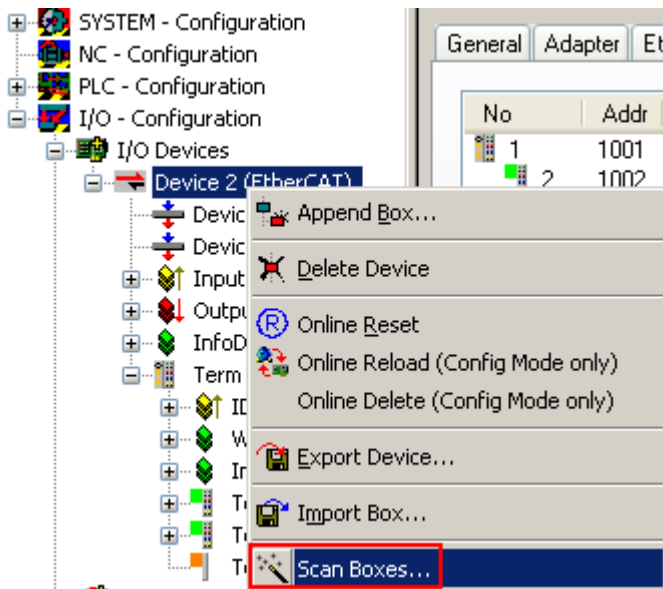

Fig. 49: Scan the subordinate field by right-clicking on the EtherCAT device

If the found field matches the configured field, the display shows



Fig. 50: Configuration is identical

otherwise a change dialog appears for entering the actual data in the configuration.

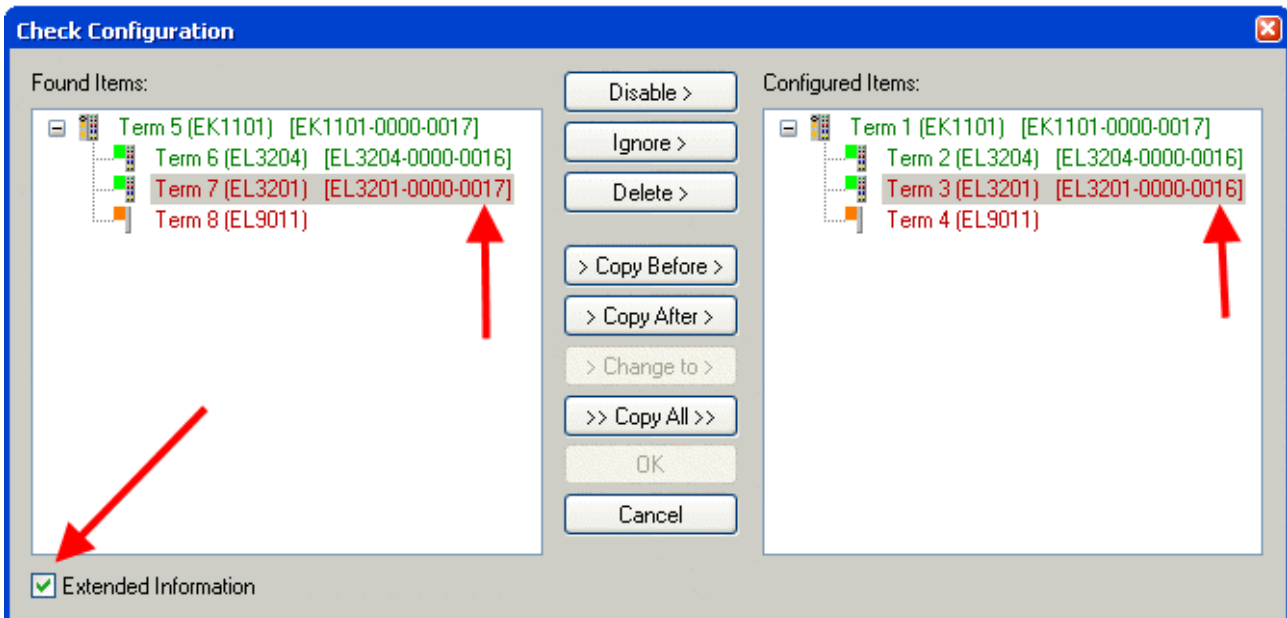

Fig. 51: Change dialog

In this example in Fig. *Change dialog*, an EL3201-0000-0017 was found, while an EL3201-0000-0016 was configured. In this case the configuration can be adapted with the *Copy Before* button. The *Extended Information* checkbox must be set in order to display the revision.

Changing the ESI slave identifier

The ESI/EEPROM identifier can be updated as follows under TwinCAT:

- Trouble-free EtherCAT communication must be established with the slave.
- The state of the slave is irrelevant.
- Right-clicking on the slave in the online display opens the *EEPROM Update* dialog, Fig. *EEPROM Update*

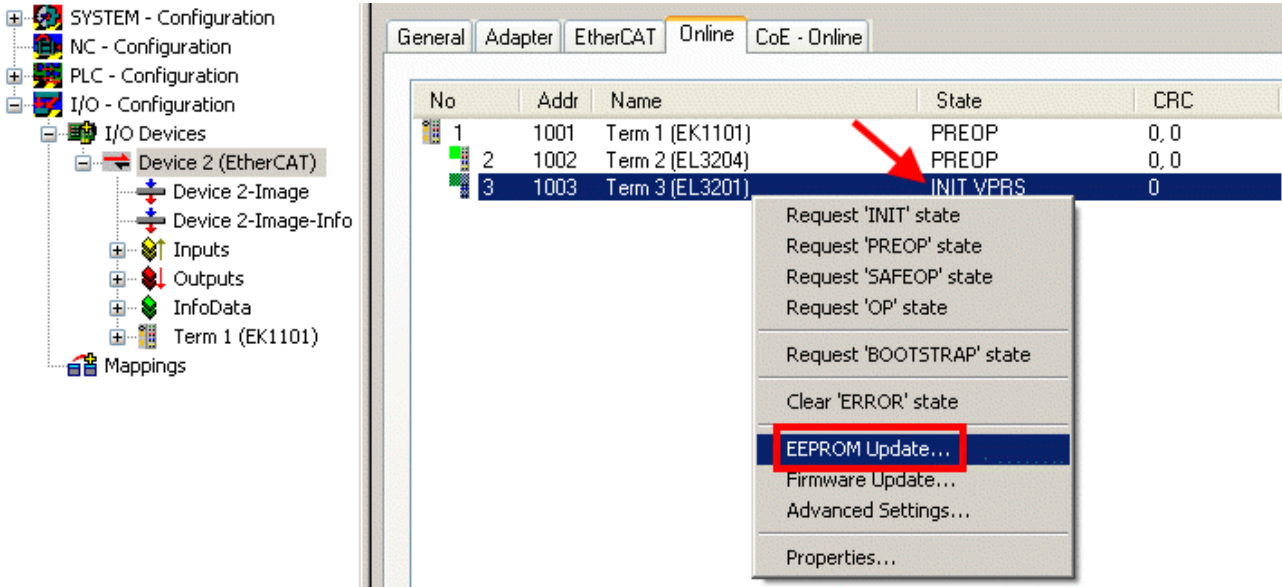

Fig. 52: EEPROM Update

The new ESI description is selected in the following dialog, see Fig. *Selecting the new ESI*. The checkbox *Show Hidden Devices* also displays older, normally hidden versions of a slave.

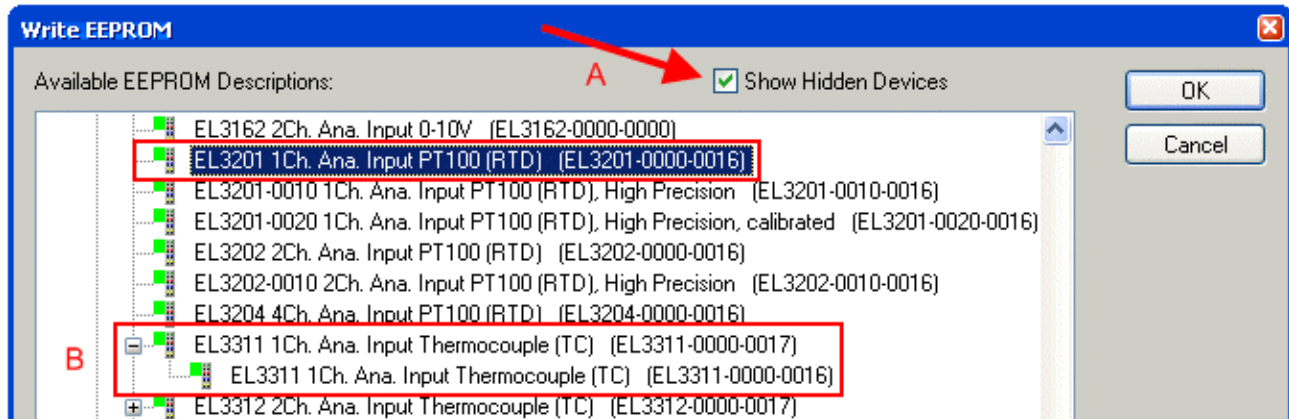

Fig. 53: Selecting the new ESI

A progress bar in the System Manager shows the progress. Data are first written, then verified.

i The change only takes effect after a restart.

Most EtherCAT devices read a modified ESI description immediately or after startup from the INIT. Some communication settings such as distributed clocks are only read during power-on. The EtherCAT slave therefore has to be switched off briefly in order for the change to take effect.

8.3.2 Firmware explanation

Determining the firmware version

Determining the version on laser inscription

Beckhoff EtherCAT slaves feature serial numbers applied by laser. The serial number has the following structure: **KK YY FF HH**

KK - week of production (CW, calendar week)
 YY - year of production
 FF - firmware version
 HH - hardware version

Example with ser. no.: 12 10 03 02:

12 - week of production 12
 10 - year of production 2010
 03 - firmware version 03
 02 - hardware version 02

Determining the version via the System Manager

The TwinCAT System Manager shows the version of the controller firmware if the master can access the slave online. Click on the E-Bus Terminal whose controller firmware you want to check (in the example terminal 2 (EL3204)) and select the tab *CoE Online* (CAN over EtherCAT).

● CoE Online and Offline CoE

i Two CoE directories are available:

- **online**: This is offered in the EtherCAT slave by the controller, if the EtherCAT slave supports this. This CoE directory can only be displayed if a slave is connected and operational.
- **offline**: The EtherCAT Slave Information ESI/XML may contain the default content of the CoE. This CoE directory can only be displayed if it is included in the ESI (e.g. "Beckhoff EL5xxx.xml").

The Advanced button must be used for switching between the two views.

In Fig. *Display of EL3204 firmware version* the firmware version of the selected EL3204 is shown as 03 in CoE entry 0x100A.

Index	Name	Flags	Value
1000	Device type	RO	0x01401389 (20976521)
1008	Device name	RO	EL3204-0000
1009	Hardware version	RO	00
100A	Software version	RO	03
1011:0	Restore default parameters	HU	> 1 <

Fig. 54: Display of EL3204 firmware version

In (A) TwinCAT 2.11 shows that the Online CoE directory is currently displayed. If this is not the case, the Online directory can be loaded via the *Online* option in Advanced Settings (B) and double-clicking on *AllObjects*.

8.3.3 Updating controller firmware *.efw

i **CoE directory**

The Online CoE directory is managed by the controller and stored in a dedicated EEPROM, which is generally not changed during a firmware update.

Switch to the *Online* tab to update the controller firmware of a slave, see Fig. *Firmware Update*.

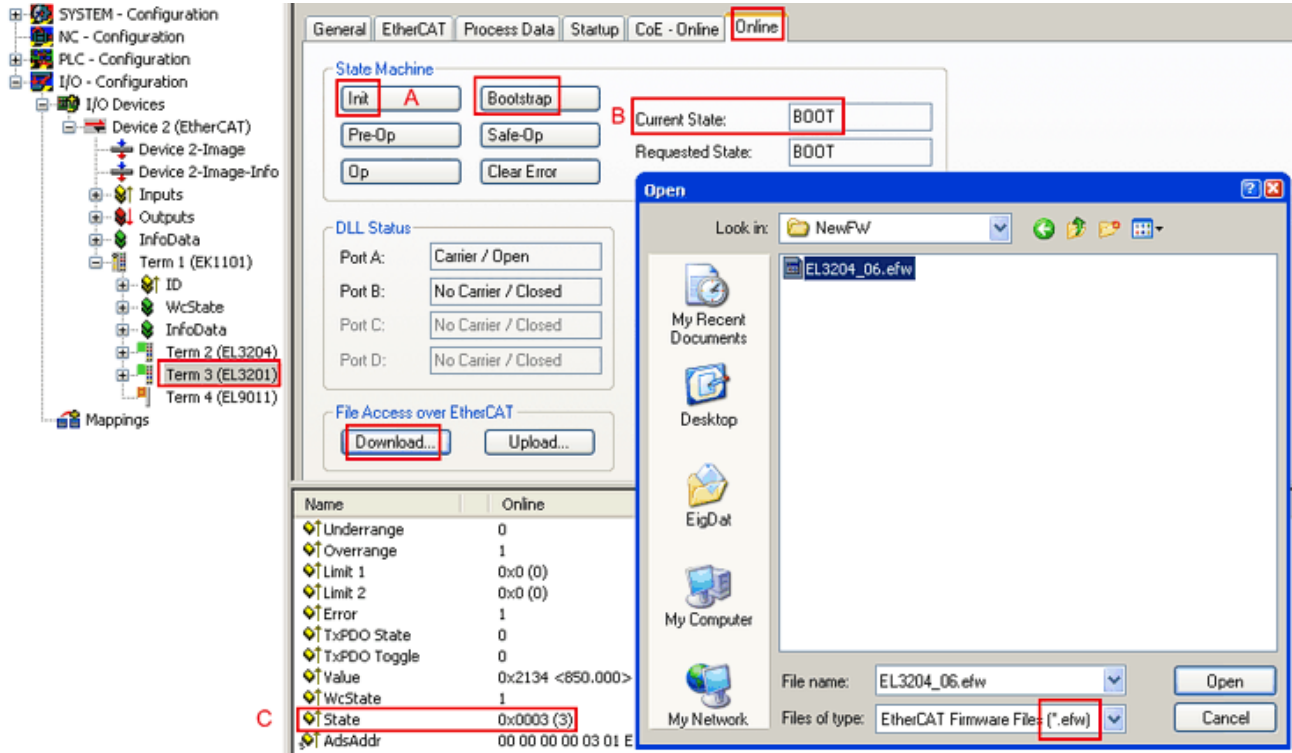
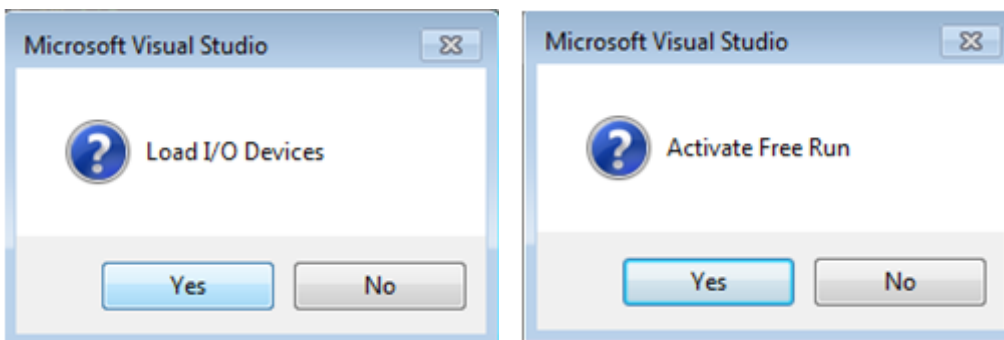

Fig. 55: Firmware Update

Proceed as follows, unless instructed otherwise by Beckhoff support. Valid for TwinCAT 2 and 3 as EtherCAT master.

- Switch TwinCAT system to ConfigMode/FreeRun with cycle time ≥ 1 ms (default in ConfigMode is 4 ms). A FW-Update during real time operation is not recommended.



- Switch EtherCAT Master to PreOP

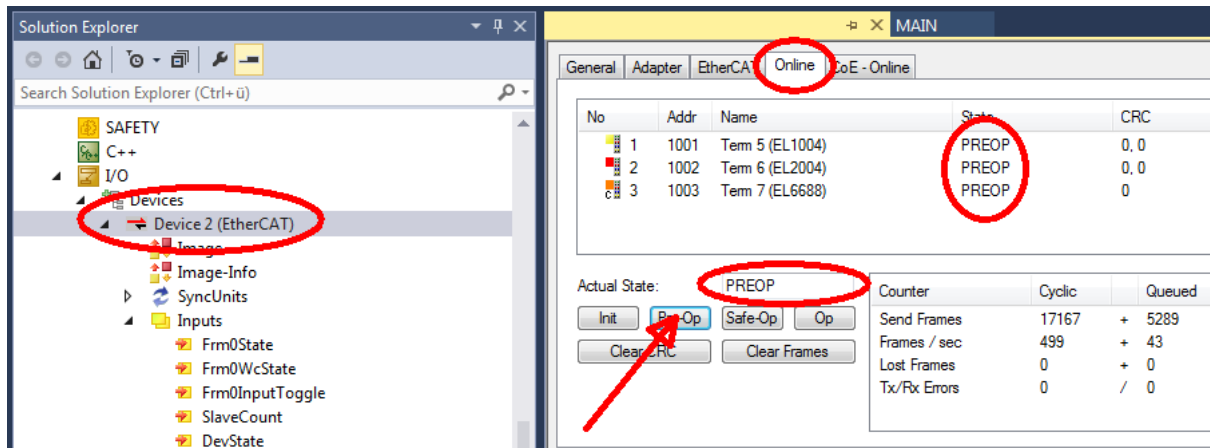

- Switch slave to INIT (A)
- Switch slave to BOOTSTRAP
- Check the current status (B, C)
- Download the new *.efw file (wait until it ends). A password will not be necessary usually.

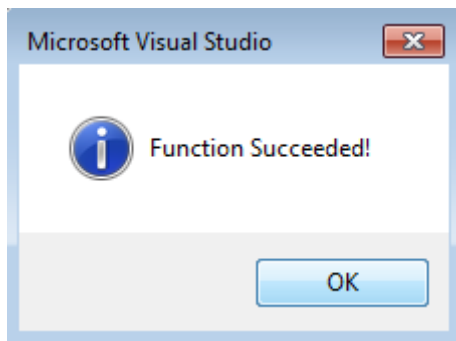

- After the download switch to INIT, then PreOP
- Switch off the slave briefly (don't pull under voltage!)
- Check within CoE 0x100A, if the FW status was correctly overtaken.

8.3.4 FPGA firmware *.rbf

If an FPGA chip deals with the EtherCAT communication an update may be accomplished via an *.rbf file.

- Controller firmware for processing I/O signals
- FPGA firmware for EtherCAT communication (only for terminals with FPGA)

The firmware version number included in the terminal serial number contains both firmware components. If one of these firmware components is modified this version number is updated.

Determining the version via the System Manager

The TwinCAT System Manager indicates the FPGA firmware version. Click on the Ethernet card of your EtherCAT strand (Device 2 in the example) and select the *Online* tab.

The *Reg:0002* column indicates the firmware version of the individual EtherCAT devices in hexadecimal and decimal representation.

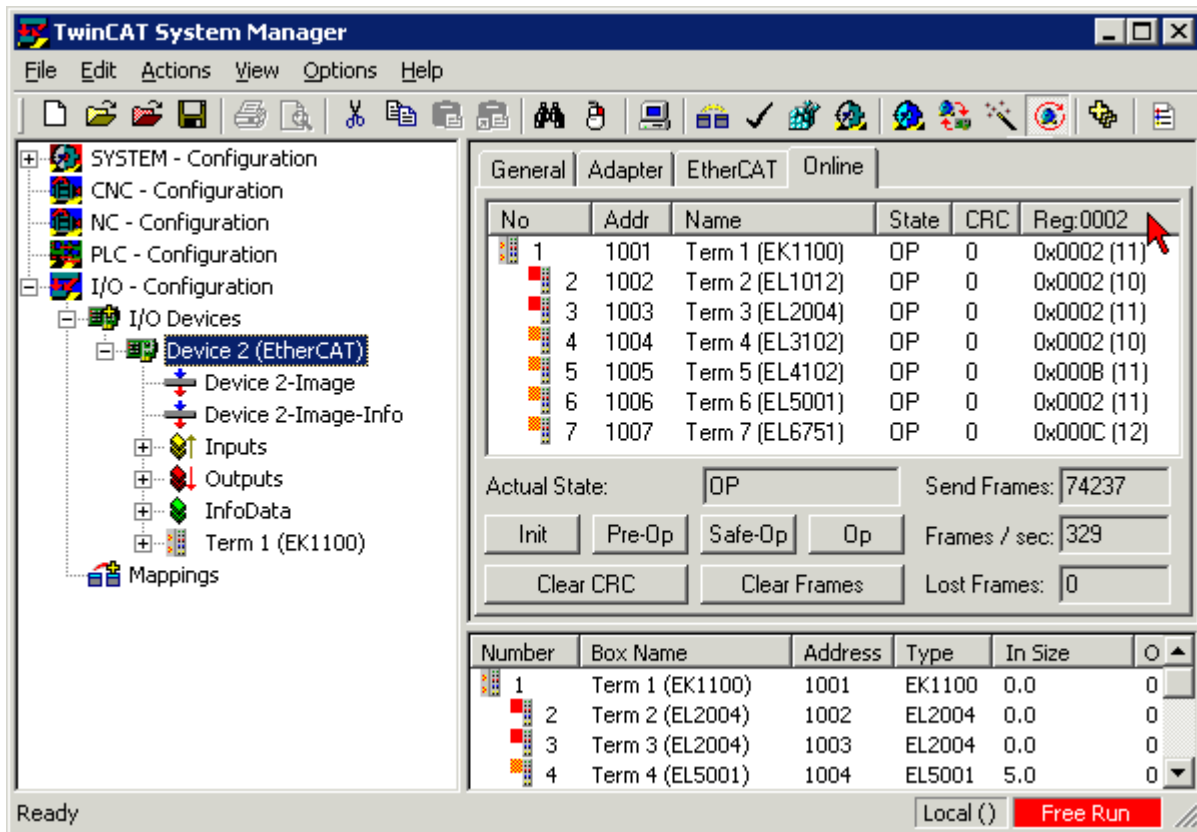

Fig. 56: FPGA firmware version definition

If the column *Reg:0002* is not displayed, right-click the table header and select *Properties* in the context menu.

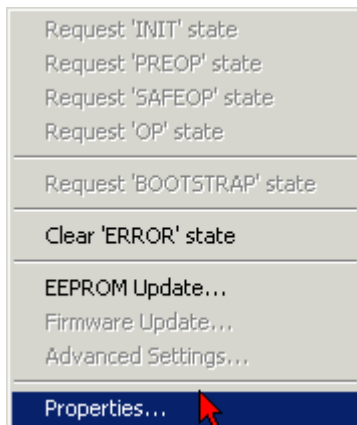

Fig. 57: Context menu *Properties*

The *Advanced Settings* dialog appears where the columns to be displayed can be selected. Under *Diagnosis/Online View* select the *'0002 ETxxxx Build'* check box in order to activate the FPGA firmware version display.

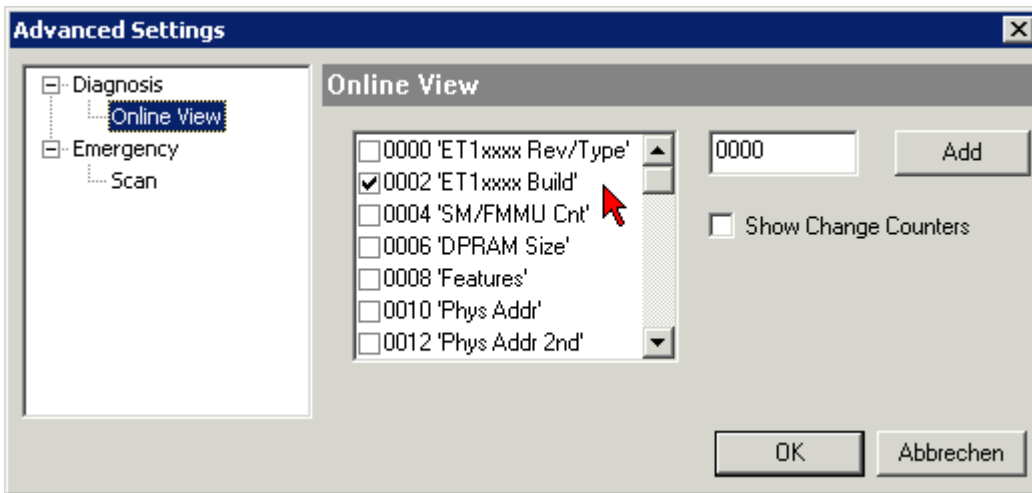

Fig. 58: Dialog *Advanced Settings*

Update

For updating the FPGA firmware

- of an EtherCAT coupler the coupler must have FPGA firmware version 11 or higher;
- of an E-Bus Terminal the terminal must have FPGA firmware version 10 or higher.

Older firmware versions can only be updated by the manufacturer!

Updating an EtherCAT device

The following sequence order have to be met if no other specifications are given (e.g. by the Beckhoff support):

- Switch TwinCAT system to ConfigMode/FreeRun with cycle time ≥ 1 ms (default in ConfigMode is 4 ms). A FW-Update during real time operation is not recommended.

- In the TwinCAT System Manager select the terminal for which the FPGA firmware is to be updated (in the example: Terminal 5: EL5001) and click the *Advanced Settings* button in the *EtherCAT* tab:

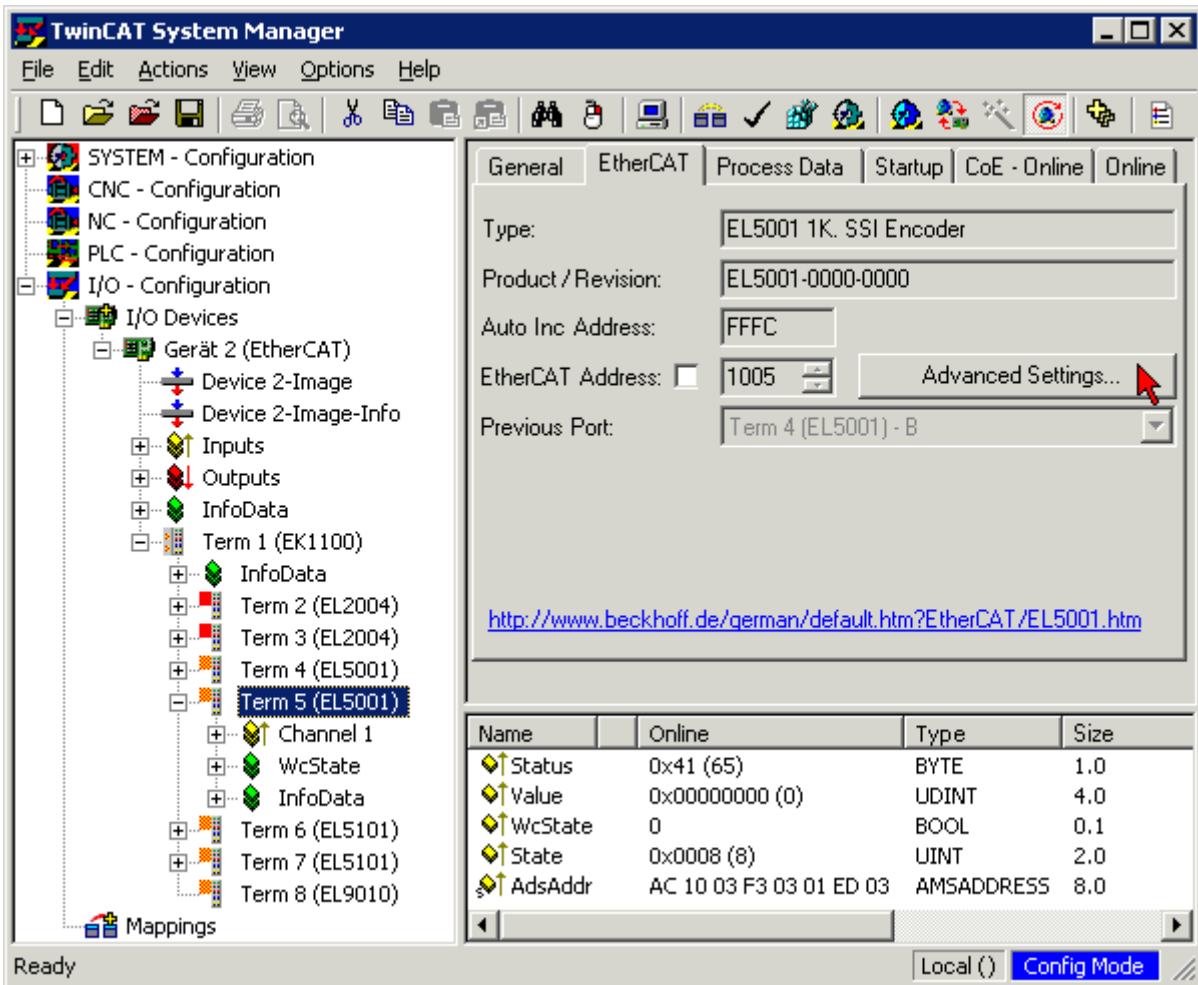

- The *Advanced Settings* dialog appears. Under *ESC Access/E²PROM/FPGA* click on *Write FPGA* button:

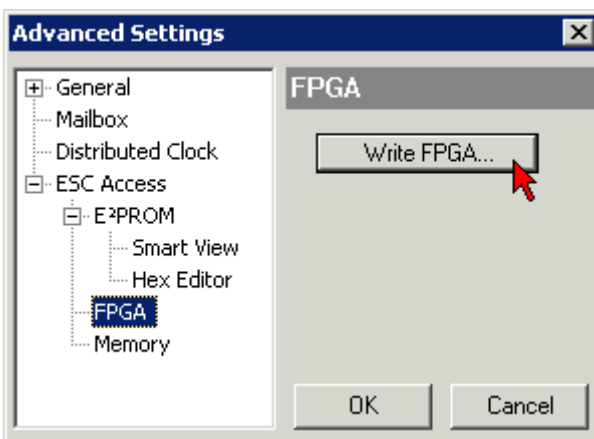

- Select the file (*.rbf) with the new FPGA firmware, and transfer it to the EtherCAT device:

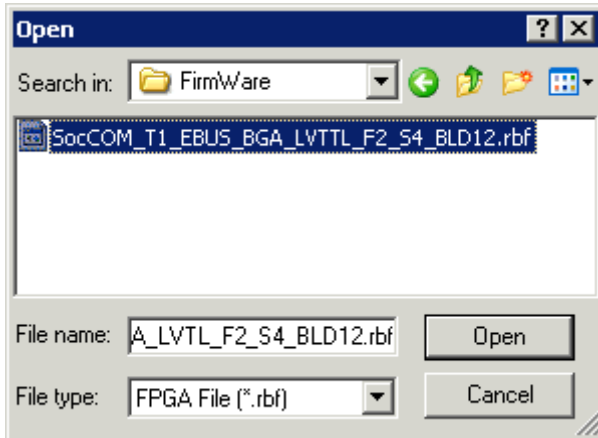

- Wait until download ends
- Switch slave current less for a short time (don't pull under voltage!). In order to activate the new FPGA firmware a restart (switching the power supply off and on again) of the EtherCAT device is required.
- Check the new FPGA status

NOTE

Risk of damage to the device!

A download of firmware to an EtherCAT device must not be interrupted in any case! If you interrupt this process by switching off power supply or disconnecting the Ethernet link, the EtherCAT device can only be recommissioned by the manufacturer!

8.3.5 Simultaneous updating of several EtherCAT devices

The firmware and ESI descriptions of several devices can be updated simultaneously, provided the devices have the same firmware file/ESI.

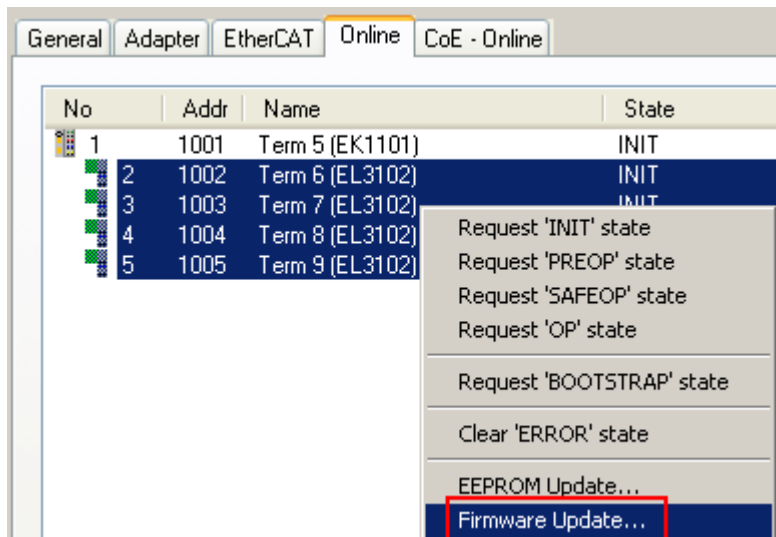

Fig. 59: Multiple selection and firmware update

Select the required slaves and carry out the firmware update in BOOTSTRAP mode as described above.

8.4 Support and Service

Beckhoff and their partners around the world offer comprehensive support and service, making available fast and competent assistance with all questions related to Beckhoff products and system solutions.

Beckhoff's branch offices and representatives

Please contact your Beckhoff branch office or representative for local support and service on Beckhoff products!

The addresses of Beckhoff's branch offices and representatives round the world can be found on her internet pages:

<http://www.beckhoff.com>

You will also find further documentation for Beckhoff components there.

Beckhoff Headquarters

Beckhoff Automation GmbH & Co. KG

Huelshorstweg 20
33415 Verl
Germany

Phone: +49(0)5246/963-0
Fax: +49(0)5246/963-198
e-mail: info@beckhoff.com

Beckhoff Support

Support offers you comprehensive technical assistance, helping you not only with the application of individual Beckhoff products, but also with other, wide-ranging services:

- support
- design, programming and commissioning of complex automation systems
- and extensive training program for Beckhoff system components

Hotline: +49(0)5246/963-157
Fax: +49(0)5246/963-9157
e-mail: support@beckhoff.com

Beckhoff Service

The Beckhoff Service Center supports you in all matters of after-sales service:

- on-site service
- repair service
- spare parts service
- hotline service

Hotline: +49(0)5246/963-460
Fax: +49(0)5246/963-479
e-mail: service@beckhoff.com

List of illustrations

Fig. 1	EL5021 EL terminal, standard IP20 IO device with serial/ batch number and revision ID (since 2014/01).....	11
Fig. 2	EK1100 EtherCAT coupler, standard IP20 IO device with serial/ batch number.....	11
Fig. 3	CU2016 switch with serial/ batch number.....	11
Fig. 4	EL3202-0020 with serial/ batch number 26131006 and unique ID-number 204418	12
Fig. 5	EP1258-00001 IP67 EtherCAT Box with batch number/ date code 22090101 and unique serial number 158102.....	12
Fig. 6	EP1908-0002 IP67 EtherCAT Safety Box with batch number/ date code 071201FF and unique serial number 00346070	12
Fig. 7	EL2904 IP20 safety terminal with batch number/ date code 50110302 and unique serial number 00331701.....	12
Fig. 8	ELM3604-0002 terminal with unique ID number (QR code) 100001051 and serial/ batch number 44160201.....	13
Fig. 9	System manager current calculation	15
Fig. 10	States of the EtherCAT State Machine.....	15
Fig. 11	EtherCAT coupler communication diagram.....	18
Fig. 12	EK18xx	20
Fig. 13	DC tab for indicating the Distributed Clocks function.....	22
Fig. 14	Advanced Distributed Clocks settings in the EtherCAT master.....	22
Fig. 15	TwinCAT setting for using this component as reference clock	23
Fig. 16	Example of an EK1100 EtherCAT coupler with 3 ports.....	24
Fig. 17	Internal and external port assignment EK1100 Bus Coupler.....	25
Fig. 18	Spring contacts of the Beckhoff I/O components.....	27
Fig. 19	Attaching on mounting rail	28
Fig. 20	Disassembling of terminal.....	29
Fig. 21	Power contact on left side.....	30
Fig. 22	Standard wiring.....	31
Fig. 23	Pluggable wiring	31
Fig. 24	High Density Terminals.....	31
Fig. 25	Mounting a cable on a terminal connection	32
Fig. 26	Correct positioning.....	34
Fig. 27	Incorrect positioning.....	34
Fig. 28	Potential connection diagram (example EK1814).....	35
Fig. 29	GND concept EK18xx.....	36
Fig. 30	Connection EK1814-0000.....	37
Fig. 31	Connection EK1818-0000.....	38
Fig. 32	Connection EK1828-0000.....	39
Fig. 33	Connection EK1828-0010.....	40
Fig. 34	TwinCAT tree EK1814.....	41
Fig. 35	Extent of process data EK1814 TwinCAT	42
Fig. 36	Extent of process data EK1814 TwinCAT	43
Fig. 37	TwinCAT tree EK1818.....	44
Fig. 38	Extent of process data EK1818 TwinCAT	45
Fig. 39	Extent of process data EK1818 TwinCAT	46
Fig. 40	TwinCAT tree EK1828.....	47
Fig. 41	Extent of process data EK1828 TwinCAT	48

Fig. 42	Extent of process data EK1828 TwinCAT	49
Fig. 43	Extent of process data EK1828 TwinCAT	50
Fig. 44	TwinCAT tree EK1828-0010	51
Fig. 45	Extent of process data EK1828-0010 TwinCAT	52
Fig. 46	Extent of process data EK1828-0010 TwinCAT	53
Fig. 47	Diagnostic LEDs	54
Fig. 48	Device identifier consisting of name EL3204-0000 and revision -0016	59
Fig. 49	Scan the subordinate field by right-clicking on the EtherCAT device	60
Fig. 50	Configuration is identical	60
Fig. 51	Change dialog	60
Fig. 52	EEPROM Update	61
Fig. 53	Selecting the new ESI.....	61
Fig. 54	Display of EL3204 firmware version	62
Fig. 55	Firmware Update	63
Fig. 56	FPGA firmware version definition	65
Fig. 57	Context menu Properties	65
Fig. 58	Dialog Advanced Settings	66
Fig. 59	Multiple selection and firmware update	68