



Documentation

EL3773

Power Monitoring Oversampling Terminal

Version: 2.5
Date: 2018-03-13

BECKHOFF

1 Product overview Power monitoring oversampling

[EL3773 \[►_14\]](#) Power monitoring oversampling terminal

6 channel analog input terminal, -410 V ... +410 V / -1.5 A ... +1.5 A with oversampling

Table of contents

1	Product overview Power monitoring oversampling	3
2	Foreword	7
2.1	Notes on the documentation	7
2.2	Safety instructions	8
2.3	Documentation issue status	9
2.4	Version identification of EtherCAT devices	9
3	Product overview	14
3.1	Introduction	14
3.2	Technical data	15
3.3	Technology	16
3.4	Start	17
4	Basics communication	18
4.1	EtherCAT basics	18
4.2	EtherCAT cabling – wire-bound	18
4.3	General notes for setting the watchdog	19
4.4	EtherCAT State Machine	21
4.5	CoE Interface	23
4.6	Distributed Clock	28
5	Mounting and wiring	29
5.1	Instructions for ESD protection	29
5.2	Installation on mounting rails	29
5.3	Installation instructions for enhanced mechanical load capacity	32
5.4	Connection	33
5.4.1	Connection system	33
5.4.2	Wiring	35
5.4.3	Shielding	36
5.5	Positioning of passive Terminals	36
5.6	Installation positions	37
5.7	Connection assignment	40
6	Commissioning	42
6.1	Quick start	42
6.2	TwinCAT Development Environment	43
6.2.1	Installation of the TwinCAT real-time driver	44
6.2.2	Notes regarding ESI device description	49
6.2.3	TwinCAT ESI Updater	53
6.2.4	Distinction between Online and Offline	53
6.2.5	OFFLINE configuration creation	54
6.2.6	ONLINE configuration creation	59
6.2.7	EtherCAT subscriber configuration	67
6.3	General Notes - EtherCAT Slave Application	76
6.4	Basic function principles	85
6.5	Process data	86
6.6	Object description and parameterization	94
6.6.1	Restore object	94
6.6.2	Configuration data	95

6.6.3	Input data	96
6.6.4	Diagnostic data	97
6.6.5	Standard objects	97
6.7	Application examples	102
6.8	Oversampling terminals and TwinCAT Scope	105
6.8.1	TwinCAT 3 procedure	106
6.8.2	TwinCAT 2 procedure	114
6.9	Current transformer	123
6.10	Notices on analog specifications	124
6.10.1	Full scale value (FSV)	124
6.10.2	Measuring error/ measurement deviation	125
6.10.3	Temperature coefficient tK [ppm/K]	125
6.10.4	Single-ended/differential typification	126
6.10.5	Common-mode voltage and reference ground (based on differential inputs)	131
6.10.6	Dielectric strength	131
6.10.7	Temporal aspects of analog/digital conversion	132
6.11	Example programs	135
6.11.1	Example 1: Diagnosis and evaluation of input data	136
6.11.2	Commissioning of the example program	139
6.11.3	Description of the function of the example program	141
6.11.4	Starting the example program	144
7	Diagnosis	148
7.1	Diagnostic methods	148
7.2	Diagnostic LEDs	149
7.3	Diagnostics – basic principles of diag messages	150
8	Appendix	160
8.1	UL notice	160
8.2	Firmware Update EL/ES/EM/EPxxxx	161
8.2.1	Device description ESI file/XML	162
8.2.2	Firmware explanation	165
8.2.3	Updating controller firmware *.efw	166
8.2.4	FPGA firmware *.rbf	167
8.2.5	Simultaneous updating of several EtherCAT devices	171
8.3	Firmware compatibility	172
8.4	Restoring the delivery state	172
8.5	Support and Service	174

2 Foreword

2.1 Notes on the documentation

Intended audience

This description is only intended for the use of trained specialists in control and automation engineering who are familiar with the applicable national standards.

It is essential that the documentation and the following notes and explanations are followed when installing and commissioning these components.

It is the duty of the technical personnel to use the documentation published at the respective time of each installation and commissioning.

The responsible staff must ensure that the application or use of the products described satisfy all the requirements for safety, including all the relevant laws, regulations, guidelines and standards.

Disclaimer

The documentation has been prepared with care. The products described are, however, constantly under development.

We reserve the right to revise and change the documentation at any time and without prior announcement.

No claims for the modification of products that have already been supplied may be made on the basis of the data, diagrams and descriptions in this documentation.

Trademarks

Beckhoff®, TwinCAT®, EtherCAT®, Safety over EtherCAT®, TwinSAFE®, XFC® and XTS® are registered trademarks of and licensed by Beckhoff Automation GmbH.

Other designations used in this publication may be trademarks whose use by third parties for their own purposes could violate the rights of the owners.

Patent Pending

The EtherCAT Technology is covered, including but not limited to the following patent applications and patents: EP1590927, EP1789857, DE102004044764, DE102007017835 with corresponding applications or registrations in various other countries.

The TwinCAT Technology is covered, including but not limited to the following patent applications and patents: EP0851348, US6167425 with corresponding applications or registrations in various other countries.

The logo for EtherCAT, featuring the word "EtherCAT" in a bold, sans-serif font. A red arrow points from the top of the "A" towards the right, ending above the "T". A registered trademark symbol (®) is located to the right of the "T".

EtherCAT® is registered trademark and patented technology, licensed by Beckhoff Automation GmbH, Germany

Copyright

© Beckhoff Automation GmbH & Co. KG, Germany.

The reproduction, distribution and utilization of this document as well as the communication of its contents to others without express authorization are prohibited.

Offenders will be held liable for the payment of damages. All rights reserved in the event of the grant of a patent, utility model or design.

2.2 Safety instructions

Safety regulations

Please note the following safety instructions and explanations!
Product-specific safety instructions can be found on following pages or in the areas mounting, wiring, commissioning etc.

Exclusion of liability





All the components are supplied in particular hardware and software configurations appropriate for the application. Modifications to hardware or software configurations other than those described in the documentation are not permitted, and nullify the liability of Beckhoff Automation GmbH & Co. KG.

Personnel qualification

This description is only intended for trained specialists in control, automation and drive engineering who are familiar with the applicable national standards.

Description of symbols

In this documentation the following symbols are used with an accompanying safety instruction or note. The safety instructions must be read carefully and followed without fail!

 DANGER	<p>Serious risk of injury! Failure to follow the safety instructions associated with this symbol directly endangers the life and health of persons.</p>
 WARNING	<p>Risk of injury! Failure to follow the safety instructions associated with this symbol endangers the life and health of persons.</p>
 CAUTION	<p>Personal injuries! Failure to follow the safety instructions associated with this symbol can lead to injuries to persons.</p>
 Attention	<p>Damage to the environment or devices Failure to follow the instructions associated with this symbol can lead to damage to the environment or equipment.</p>
 Note	<p>Tip or pointer This symbol indicates information that contributes to better understanding.</p>

2.3 Documentation issue status

Version	Comment
2.5	<ul style="list-style-type: none"> • Update chapter "Process data" • Update structure • Update revision status
2.4	<ul style="list-style-type: none"> • Update chapter "Notes on the documentation" • Update chapter "Technical data" • Addenda chapter "Instructions for ESD protection" • Update chapter "TwinCAT 2.1x" -> "TwinCAT Development Environment" • Update chapter "Notices on Analog specification" • Update revision status
2.3	<ul style="list-style-type: none"> • Chapter "TwinCAT Scope2" replaced by chapter "Oversampling terminals and TwinCAT Scope"
2.2	<ul style="list-style-type: none"> • Update programming sample • Update structure • Update revision status
2.1	<ul style="list-style-type: none"> • Update programming sample • Update structure • Update revision status
2.0	<ul style="list-style-type: none"> • Migration • Update structure • Update revision status
1.5	<ul style="list-style-type: none"> • Update structure • Update chapter "Connection"
1.4	<ul style="list-style-type: none"> • Update chapter "Technical data"
1.3	<ul style="list-style-type: none"> • Addenda chapter "Data visualization in TwinCAT Scope2"
1.2	<ul style="list-style-type: none"> • Addenda to example program
1.1	<ul style="list-style-type: none"> • Addenda
1.0	<ul style="list-style-type: none"> • Addenda and 1st public issue
0.1 - 0.3	<ul style="list-style-type: none"> • preliminary documentation for EL3773

2.4 Version identification of EtherCAT devices

Designation

A Beckhoff EtherCAT device has a 14-digit designation, made up of

- family key
- type
- version
- revision

Example	Family	Type	Version	Revision
EL3314-0000-0016	EL terminal (12 mm, non-pluggable connection level)	3314 (4-channel thermocouple terminal)	0000 (basic type)	0016
ES3602-0010-0017	ES terminal (12 mm, pluggable connection level)	3602 (2-channel voltage measurement)	0010 (high-precision version)	0017
CU2008-0000-0000	CU device	2008 (8-port fast ethernet switch)	0000 (basic type)	0000

Notes

- The elements mentioned above result in the **technical designation**. EL3314-0000-0016 is used in the example below.
- EL3314-0000 is the order identifier, in the case of “-0000” usually abbreviated to EL3314. “-0016” is the EtherCAT revision.
- The **order identifier** is made up of
 - family key (EL, EP, CU, ES, KL, CX, etc.)
 - type (3314)
 - version (-0000)
- The **revision** -0016 shows the technical progress, such as the extension of features with regard to the EtherCAT communication, and is managed by Beckhoff.
In principle, a device with a higher revision can replace a device with a lower revision, unless specified otherwise, e.g. in the documentation.
Associated and synonymous with each revision there is usually a description (ESI, EtherCAT Slave Information) in the form of an XML file, which is available for download from the Beckhoff web site.
From 2014/01 the revision is shown on the outside of the IP20 terminals, see Fig. “EL5021 EL terminal, standard IP20 IO device with batch number and revision ID (since 2014/01)”.
- The type, version and revision are read as decimal numbers, even if they are technically saved in hexadecimal.

Identification number

Beckhoff EtherCAT devices from the different lines have different kinds of identification numbers:

Production lot/batch number/serial number/date code/D number

The serial number for Beckhoff IO devices is usually the 8-digit number printed on the device or on a sticker. The serial number indicates the configuration in delivery state and therefore refers to a whole production batch, without distinguishing the individual modules of a batch.

Structure of the serial number: **KK YY FF HH**

KK - week of production (CW, calendar week)
 YY - year of production
 FF - firmware version
 HH - hardware version

Example with

Ser. no.: 12063A02: 12 - production week 12 06 - production year 2006 3A - firmware version 3A 02 - hardware version 02

Exceptions can occur in the **IP67 area**, where the following syntax can be used (see respective device documentation):

Syntax: D ww yy x y z u

D - prefix designation
 ww - calendar week
 yy - year
 x - firmware version of the bus PCB

y - hardware version of the bus PCB
 z - firmware version of the I/O PCB
 u - hardware version of the I/O PCB

Example: D.22081501 calendar week 22 of the year 2008 firmware version of bus PCB: 1 hardware version of bus PCB: 5 firmware version of I/O PCB: 0 (no firmware necessary for this PCB) hardware version of I/O PCB: 1

Unique serial number/ID, ID number

In addition, in some series each individual module has its own unique serial number.

See also the further documentation in the area

- IP67: [EtherCAT Box](#)
- Safety: [TwinSafe](#)
- Terminals with factory calibration certificate and other measuring terminals

Examples of markings



Fig. 1: EL5021 EL terminal, standard IP20 IO device with serial/ batch number and revision ID (since 2014/01)



Fig. 2: EK1100 EtherCAT coupler, standard IP20 IO device with serial/ batch number



Fig. 3: CU2016 switch with serial/ batch number

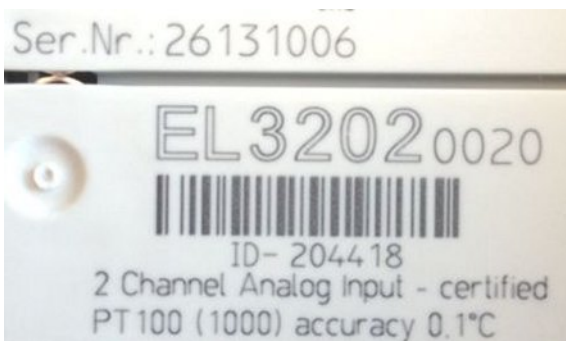

Fig. 4: EL3202-0020 with serial/ batch number 26131006 and unique ID-number 204418

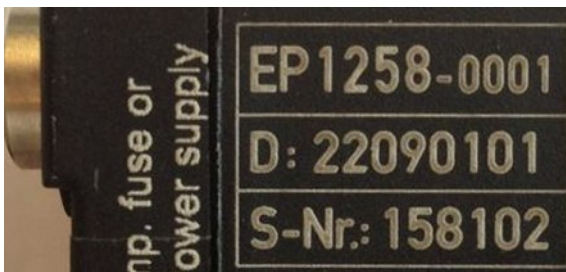

Fig. 5: EP1258-0001 IP67 EtherCAT Box with batch number/ date code 22090101 and unique serial number 158102

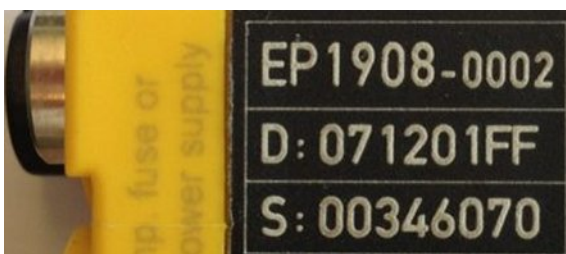

Fig. 6: EP1908-0002 IP67 EtherCAT Safety Box with batch number/ date code 071201FF and unique serial number 00346070



Fig. 7: EL2904 IP20 safety terminal with batch number/ date code 50110302 and unique serial number 00331701



Fig. 8: ELM3604-0002 terminal with unique ID number (QR code) 100001051 and serial/ batch number 44160201

3 Product overview

3.1 Introduction

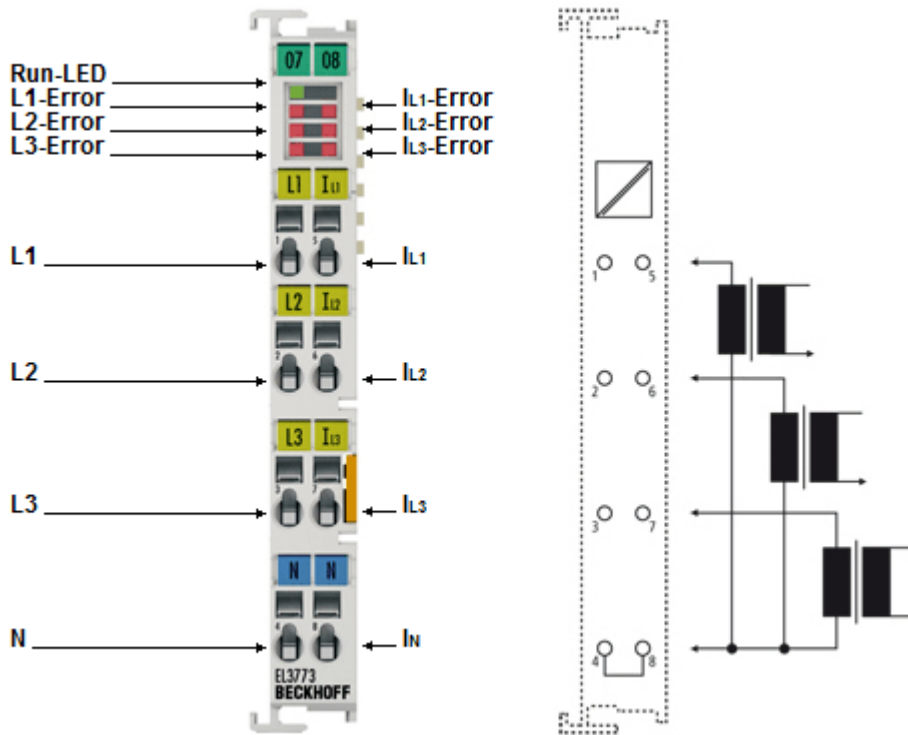

Fig. 9: EL3773

Power monitoring oversampling terminal

The EL3773 EtherCAT Terminal is designed as a power monitoring terminal for the state monitoring of a 3-phase AC voltage system (rated mains voltage 230/400 V_{rms}). For each phase voltages up to 288 V_{rms}/410 V_{DC} and currents up to 1 A_{rms}/1.5 A_{DC} are sampled as instantaneous values with a resolution of 16 bit.

The six channels are measured simultaneously based on the EtherCAT oversampling principle with a temporal resolution of up to 100 μs and passed on to the controller. The controller has sufficient computing power for true RMS or performance calculation and complex custom algorithms based on the measured voltages and currents.

Through the oversampling principle the terminal is able to measure at significantly shorter intervals than the cycle time of the controller. AC and DC parameters must be connected and measured with a common reference potential.

The EL3773 supports distributed clocks for measuring synchronously with other EtherCAT devices, but can also be operated without distributed clocks.



Note

RMS value (rms) specifications

All AC value specifications in this documentation such as RMS specifications (rms) refer to a 50/60 Hz 3-phase mains network with a sinusoidal waveform (crest factor 1.414).

Quick links

- [EtherCAT basics \[▶ 18\]](#)
- [Quick start \[▶ 42\]](#)
- [Creation of the configuration \[▶ 43\]](#)
- [Process data \[▶ 86\]](#)

- [CoE object description \[► 94\]](#)

3.2 Technical data



Note

RMS value (rms) specifications

All AC value specifications in this documentation such as RMS specifications (rms) refer to a 50/60 Hz 3-phase mains network with a sinusoidal waveform (crest factor 1.414).

Technical data	EL3773
Number of inputs	3 x current, 3 x voltage
Oversampling factor	n = 1...100 selectable
Distributed Clocks	yes
Accuracy of Distributed Clocks	<< 1 µs
Input filter limit frequency	adjustable, 200 ... 15,000 Hz
Conversion time	min. 100 µs, all channels measured simultaneously
Rated mains voltage	230 V _{rms} (UL _x -N) or 400 V _{rms} (UL _x -UL _y)
Voltage measuring range (nominal range)	DC: ±410 V AC accordingly: 500 V _{rms} AC 3~ (UL _x -N: 288 V _{rms} AC) common reference potential N/GND*
Max. permitted overvoltage	max. ±500 V (peak value, UL _x -N, corresponds with 353 V _{rms}) *
Voltage resolution	1 digit ~ 12.5 mV (16 bit incl. sign)
Input resistance voltage circuit	typ. 1.8 MΩ
Current measuring range (nominal range)	DC: ±1.5 A AC accordingly: 3 x 1 A _{rms} * AC recommended via measuring transformer x A AC/1 A AC
Max. permitted overcurrent	max. ±1.8 A (peak value, corresponds with 1.2 A _{rms}) * the upstream use of current/limiting current transformers is recommended
Current resolution	1 digit ~ 45.7 µA (16 bit incl. sign)
Input resistance current path	typ. 30 mΩ
Signal type	variable
Measuring error (for DC measuring)	< ±0.5 % (relative to full scale value)
Electrical isolation	2,500 V
Current consumption of power contacts	-
Current consumption via E-bus	200 mA typ.
Configuration	via TwinCAT System Manager
Weight	approx. 75 g
permissible ambient temperature range during operation	0°C ... +55°C
permissible ambient temperature range during storage	-25°C ... +85°C
permissible relative humidity	95 %, no condensation
Dimensions (W x H x D)	approx. 15 mm x 100 mm x 70 mm
Mounting [► 29]	on 35 mm mounting rail conforms to EN 60715
Vibration/shock resistance	conforms to EN 60068-2-6 / EN 60068-2-27, see also installation instructions for enhanced mechanical load capacity [► 32]
EMC immunity/emission	conforms to EN 61000-6-2 / EN 61000-6-4
Protection class	IP20
Installation position	variable
Approval	CE, cULus. [► 160]

* operation for longer periods above the rated range can impair the function and/or lead to a shortening of the service life

3.3 Technology

Measurement of AC variables with the EL3773

Normal three-phase mains supply

The normal 3-phase low-voltage grids in Central Europe are characterized by the following interrelationship: rated voltage is usually the effective voltage U_{RMS} , e.g. $230 V_{RMS}$, as a star voltage between one of the three live conductors (L1, L2 or L3) and neutral N.

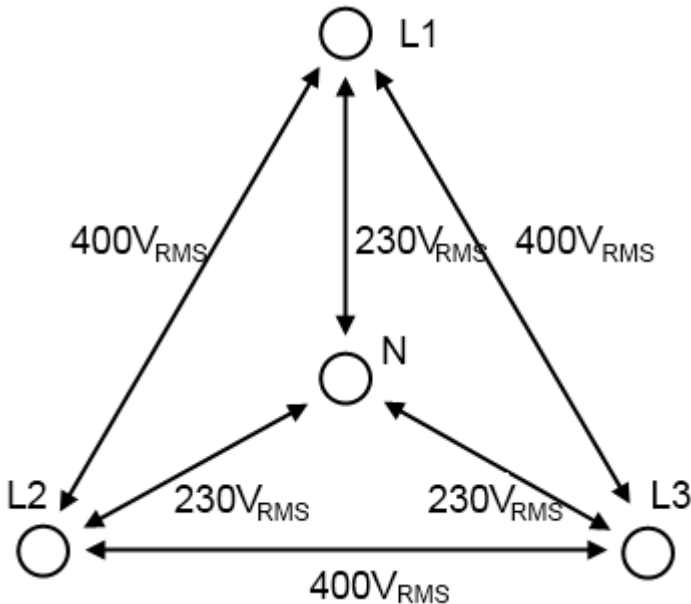



Fig. 10: Voltages in three-phase mains supply of Central Europe

With a pure sinusoidal oscillation (unloaded grid) a maximum peak voltage (max. amplitude) of approx.

$\pm 325V_{peak}$ to N is calculated from the then valid crest factor from $\sqrt{2}$ in the star voltage.

A phase-to-phase voltage of $230V \cdot \sqrt{3} \approx 400V$ (RMS) can be measured between the live conductors.

RMS value specifications

 Note	RMS value (r_{ms}) specifications All AC value specifications in this documentation such as RMS specifications (r_{ms}) refer to a 50/60 Hz 3-phase mains network with a sinusoidal waveform.
--	--

The EL3773 EtherCAT Terminal is a power monitoring terminal for state monitoring of a 3-phase AC voltage system. The following properties are characteristic of the EL3773:

- 3 channels measure -410 to $+410 V$ to N through analog-to-digital converters in 16-bit resolution as amplitude value
- 3 channels measure -1.5 to $+1.5 A$ to N through analog-to-digital converters in 16-bit resolution as amplitude value
- all 6 analog input channels are measured simultaneously
- the EL3773 is an oversampling terminal and can therefore record not just 1, but up to 100 samples (amplitude values) per channel in each PLC/EtherCAT cycle. These are sent as a data packet to the controller via the cyclic process data.
The minimum sampling time is $100 \mu s$, corresponding to 10,000 samples/second.

- The voltage and current curve can have any form; the EL3773 is thus suitable for AC and DC measurements
- various filter functions (low-pass and notch filter) are available for each channel
- the EL3773 can be synchronized with other EtherCAT device over Distributed Clocks, but can also be operated without Distributed Clocks with oversampling
- no pre-evaluations or calculations of the amplitude values take place in the EL3773

Hence, the EL3773 is suitable for very different applications, for example

- 3-phase monitoring: the voltage and current to N are measured for a 3-phase load
- 3-load monitoring: the voltage and current to N can be measured for 3 loads even if connected to the same phase
- each channel can measure as desired, provided the measured is referred to N (or GND in DC networks)
- Measurement of non-sinusoidal amplitude curves, including rectangular or DC curves

Evaluations and calculations of the raw data sent to the controller, such as active power (P), cumulative power consumption (W) or power factor ($\cos \varphi$) must take place in the controller. The controller has sufficient computing power for true RMS or performance calculation and complex custom algorithms based on the measured voltages and currents.

**Note****Design of voltage measuring range**

Low-voltage power supply systems are defined, for example, in IEC 60038. Since 2003 the specification here is $230/400 V_{\text{RMS}} \pm 10\%$, corresponding to $\pm 357 V_{\text{peak}}$. So that substantial spikes can also be measured, the EL3773 supports a measuring range of $288 V_{\text{RMS}} \text{ AC}$, corresponding to $\pm 407 V_{\text{peak}}$ (nominal: $\pm 410 \text{ V}$).

3.4 Start

For commissioning:

- Install the EL3773 as described in section [Mounting and wiring](#) [► 29].
- configure the EL3773 in TwinCAT as described in the chapter [Commissioning](#) [► 42].

4 Basics communication

4.1 EtherCAT basics

Please refer to the chapter [EtherCAT System Documentation](#) for the EtherCAT fieldbus basics.

4.2 EtherCAT cabling – wire-bound

The cable length between two EtherCAT devices must not exceed 100 m. This results from the FastEthernet technology, which, above all for reasons of signal attenuation over the length of the cable, allows a maximum link length of 5 + 90 + 5 m if cables with appropriate properties are used. See also the [Design recommendations for the infrastructure for EtherCAT/Ethernet](#).

Cables and connectors

For connecting EtherCAT devices only Ethernet connections (cables + plugs) that meet the requirements of at least category 5 (Cat5) according to EN 50173 or ISO/IEC 11801 should be used. EtherCAT uses 4 wires for signal transfer.

EtherCAT uses RJ45 plug connectors, for example. The pin assignment is compatible with the Ethernet standard (ISO/IEC 8802-3).

Pin	Color of conductor	Signal	Description
1	yellow	TD +	Transmission Data +
2	orange	TD -	Transmission Data -
3	white	RD +	Receiver Data +
6	blue	RD -	Receiver Data -

Due to automatic cable detection (auto-crossing) symmetric (1:1) or cross-over cables can be used between EtherCAT devices from Beckhoff.



Note

Recommended cables

Suitable cables for the connection of EtherCAT devices can be found on the Beckhoff website!

E-Bus supply

A bus coupler can supply the EL terminals added to it with the E-bus system voltage of 5 V; a coupler is thereby loadable up to 2 A as a rule (see details in respective device documentation).

Information on how much current each EL terminal requires from the E-bus supply is available online and in the catalogue. If the added terminals require more current than the coupler can supply, then power feed terminals (e.g. [EL9410](#)) must be inserted at appropriate places in the terminal strand.

The pre-calculated theoretical maximum E-Bus current is displayed in the TwinCAT System Manager. A shortfall is marked by a negative total amount and an exclamation mark; a power feed terminal is to be placed before such a position.

Number	Box Name	Add...	Type	In Si...	Out ...	E-Bus (mA)
1	Term 1 (EK1100)	1001	EK1100			
2	Term 2 (EL2008)	1002	EL2008		1.0	1890
3	Term 3 (EL2008)	1003	EL2008		1.0	1780
4	Term 4 (EL2008)	1004	EL2008		1.0	1670
5	Term 5 (EL6740...)	1005	EL6740-0010	2.0	2.0	1220
6	Term 6 (EL6740...)	1006	EL6740-0010	2.0	2.0	770
7	Term 7 (EL6740...)	1007	EL6740-0010	2.0	2.0	320
8	Term 8 (EL6740...)	1008	EL6740-0010	2.0	2.0	-130 I
9	Term 9 (EL6740...)	1009	EL6740-0010	2.0	2.0	-580 I

Fig. 11: System manager current calculation

 Attention	<p>Malfunction possible!</p> <p>The same ground potential must be used for the E-Bus supply of all EtherCAT terminals in a terminal block!</p>
----------------------	---

4.3 General notes for setting the watchdog

ELxxx terminals are equipped with a safety feature (watchdog) that switches off the outputs after a specifiable time e.g. in the event of an interruption of the process data traffic, depending on the device and settings, e.g. in OFF state.

The EtherCAT slave controller (ESC) in the EL2xxx terminals features 2 watchdogs:

- SM watchdog (default: 100 ms)
- PDI watchdog (default: 100 ms)

SM watchdog (SyncManager Watchdog)

The SyncManager watchdog is reset after each successful EtherCAT process data communication with the terminal. If no EtherCAT process data communication takes place with the terminal for longer than the set and activated SM watchdog time, e.g. in the event of a line interruption, the watchdog is triggered and the outputs are set to FALSE. The OP state of the terminal is unaffected. The watchdog is only reset after a successful EtherCAT process data access. Set the monitoring time as described below.

The SyncManager watchdog monitors correct and timely process data communication with the ESC from the EtherCAT side.

PDI watchdog (Process Data Watchdog)

If no PDI communication with the EtherCAT slave controller (ESC) takes place for longer than the set and activated PDI watchdog time, this watchdog is triggered.

PDI (Process Data Interface) is the internal interface between the ESC and local processors in the EtherCAT slave, for example. The PDI watchdog can be used to monitor this communication for failure.

The PDI watchdog monitors correct and timely process data communication with the ESC from the application side.

The settings of the SM- and PDI-watchdog must be done for each slave separately in the TwinCAT System Manager.

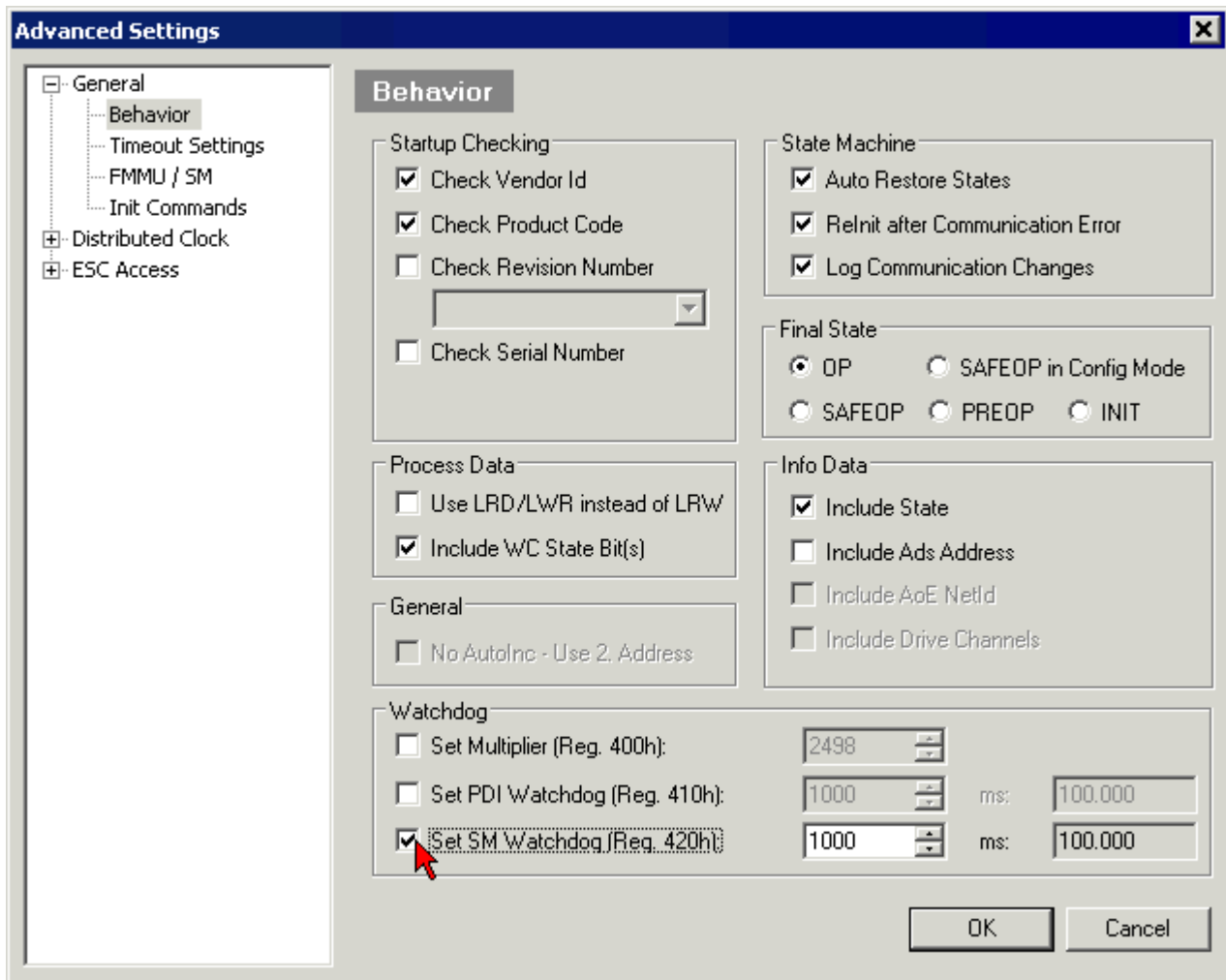

Fig. 12: EtherCAT tab -> Advanced Settings -> Behavior -> Watchdog

Notes:

- the multiplier is valid for both watchdogs.
- each watchdog has its own timer setting, the outcome of this in summary with the multiplier is a resulting time.
- Important: the multiplier/timer setting is only loaded into the slave at the start up, if the checkbox is activated.
If the checkbox is not activated, nothing is downloaded and the ESC settings remain unchanged.

Multiplier

Multiplier

Both watchdogs receive their pulses from the local terminal cycle, divided by the watchdog multiplier:

$$1/25 \text{ MHz} * (\text{watchdog multiplier} + 2) = 100 \mu\text{s} \text{ (for default setting of 2498 for the multiplier)}$$

The standard setting of 1000 for the SM watchdog corresponds to a release time of 100 ms.

The value in multiplier + 2 corresponds to the number of basic 40 ns ticks representing a watchdog tick. The multiplier can be modified in order to adjust the watchdog time over a larger range.

Example "Set SM watchdog"

This checkbox enables manual setting of the watchdog times. If the outputs are set and the EtherCAT communication is interrupted, the SM watchdog is triggered after the set time and the outputs are erased. This setting can be used for adapting a terminal to a slower EtherCAT master or long cycle times. The default SM watchdog setting is 100 ms. The setting range is 0..65535. Together with a multiplier with a range of 1..65535 this covers a watchdog period between 0..~170 seconds.

Calculation

Multiplier = 2498 → watchdog base time = 1 / 25 MHz * (2498 + 2) = 0.0001 seconds = 100 μs
 SM watchdog = 10000 → 10000 * 100 μs = 1 second watchdog monitoring time

 CAUTION	<p>Undefined state possible!</p> <p>The function for switching off of the SM watchdog via SM watchdog = 0 is only implemented in terminals from version -0016. In previous versions this operating mode should not be used.</p>
---	--

 CAUTION	<p>Damage of devices and undefined state possible!</p> <p>If the SM watchdog is activated and a value of 0 is entered the watchdog switches off completely. This is the deactivation of the watchdog! Set outputs are NOT set in a safe state, if the communication is interrupted.</p>
---	--

4.4 EtherCAT State Machine

The state of the EtherCAT slave is controlled via the EtherCAT State Machine (ESM). Depending upon the state, different functions are accessible or executable in the EtherCAT slave. Specific commands must be sent by the EtherCAT master to the device in each state, particularly during the bootup of the slave.

A distinction is made between the following states:

- Init
- Pre-Operational
- Safe-Operational and
- Operational
- Boot

The regular state of each EtherCAT slave after bootup is the OP state.

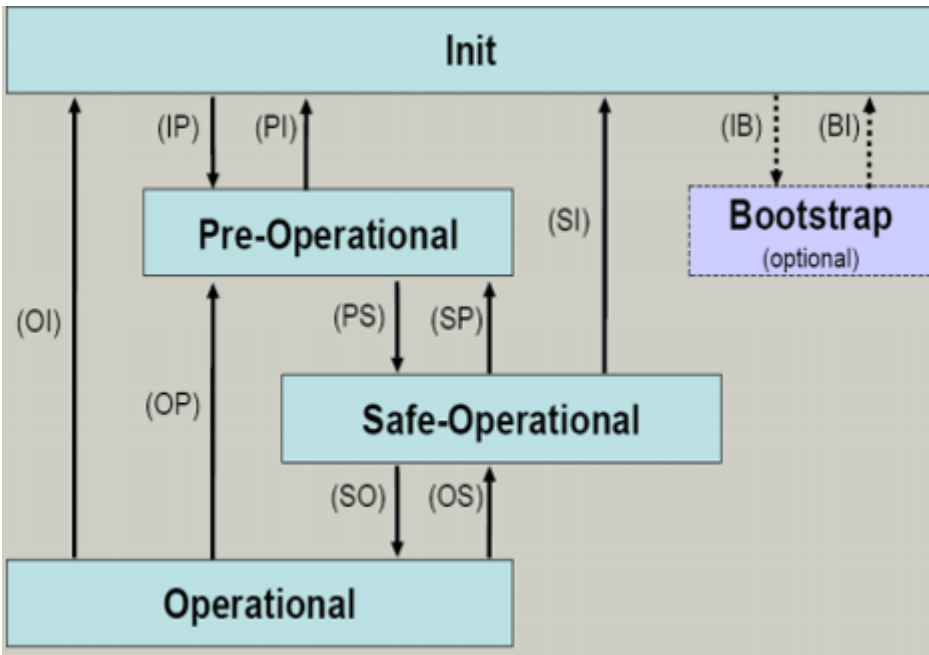

Fig. 13: States of the EtherCAT State Machine

Init

After switch-on the EtherCAT slave in the *Init* state. No mailbox or process data communication is possible. The EtherCAT master initializes sync manager channels 0 and 1 for mailbox communication.

Pre-Operational (Pre-Op)

During the transition between *Init* and *Pre-Op* the EtherCAT slave checks whether the mailbox was initialized correctly.

In *Pre-Op* state mailbox communication is possible, but not process data communication. The EtherCAT master initializes the sync manager channels for process data (from sync manager channel 2), the FMMU channels and, if the slave supports configurable mapping, PDO mapping or the sync manager PDO assignment. In this state the settings for the process data transfer and perhaps terminal-specific parameters that may differ from the default settings are also transferred.

Safe-Operational (Safe-Op)

During transition between *Pre-Op* and *Safe-Op* the EtherCAT slave checks whether the sync manager channels for process data communication and, if required, the distributed clocks settings are correct. Before it acknowledges the change of state, the EtherCAT slave copies current input data into the associated DP-RAM areas of the EtherCAT slave controller (ECSC).

In *Safe-Op* state mailbox and process data communication is possible, although the slave keeps its outputs in a safe state, while the input data are updated cyclically.



Note

Outputs in SAFEOP state

The default set `watchdog` [► 19] monitoring sets the outputs of the module in a safe state - depending on the settings in SAFEOP and OP - e.g. in OFF state. If this is prevented by deactivation of the watchdog monitoring in the module, the outputs can be switched or set also in the SAFEOP state.

Operational (Op)

Before the EtherCAT master switches the EtherCAT slave from *Safe-Op* to *Op* it must transfer valid output data.

In the *Op* state the slave copies the output data of the masters to its outputs. Process data and mailbox communication is possible.

Boot

In the *Boot* state the slave firmware can be updated. The *Boot* state can only be reached via the *Init* state.

In the *Boot* state mailbox communication via the *file access over EtherCAT* (FoE) protocol is possible, but no other mailbox communication and no process data communication.

4.5 CoE Interface

General description

The CoE interface (CANopen over EtherCAT) is used for parameter management of EtherCAT devices. EtherCAT slaves or the EtherCAT master manage fixed (read only) or variable parameters which they require for operation, diagnostics or commissioning.

CoE parameters are arranged in a table hierarchy. In principle, the user has read access via the fieldbus. The EtherCAT master (TwinCAT System Manager) can access the local CoE lists of the slaves via EtherCAT in read or write mode, depending on the attributes.

Different CoE parameter types are possible, including string (text), integer numbers, Boolean values or larger byte fields. They can be used to describe a wide range of features. Examples of such parameters include manufacturer ID, serial number, process data settings, device name, calibration values for analog measurement or passwords.

The order is specified in 2 levels via hexadecimal numbering: (main)index, followed by subindex. The value ranges are

- Index: 0x0000 ...0xFFFF (0...65535_{dez})
- SubIndex: 0x00...0xFF (0...255_{dez})

A parameter localized in this way is normally written as 0x8010:07, with preceding "x" to identify the hexadecimal numerical range and a colon between index and subindex.

The relevant ranges for EtherCAT fieldbus users are:

- 0x1000: This is where fixed identity information for the device is stored, including name, manufacturer, serial number etc., plus information about the current and available process data configurations.
- 0x8000: This is where the operational and functional parameters for all channels are stored, such as filter settings or output frequency.

Other important ranges are:

- 0x4000: In some EtherCAT devices the channel parameters are stored here (as an alternative to the 0x8000 range).
- 0x6000: Input PDOs ("input" from the perspective of the EtherCAT master)
- 0x7000: Output PDOs ("output" from the perspective of the EtherCAT master)



Note

Availability

Not every EtherCAT device must have a CoE list. Simple I/O modules without dedicated processor usually have no variable parameters and therefore no CoE list.

If a device has a CoE list, it is shown in the TwinCAT System Manager as a separate tab with a listing of the elements:

Index	Name	Flags	Value
1000	Device type	RO	0x00FA1389 (16389001)
1008	Device name	RO	EL2502-0000
1009	Hardware version	RO	
100A	Software version	RO	
1011:0	Restore default parameters	RO	> 1 <
1018:0	Identity	RO	> 4 <
1018:01	Vendor ID	RO	0x00000002 (2)
1018:02	Product code	RO	0x09C63052 (163983442)
1018:03	Revision	RO	0x00130000 (1245184)
1018:04	Serial number	RO	0x00000000 (0)
10F0:0	Backup parameter handling	RO	> 1 <
1400:0	PwM RxDPO-Par Ch.1	RO	> 6 <
1401:0	PwM RxDPO-Par Ch.2	RO	> 6 <
1402:0	PwM RxDPO-Par h.1 Ch.1	RO	> 6 <
1403:0	PwM RxDPO-Par h.1 Ch.2	RO	> 6 <
1600:0	PwM RxDPO-Map Ch.1	RO	> 1 <

Fig. 14: "CoE Online " tab

The figure above shows the CoE objects available in device "EL2502", ranging from 0x1000 to 0x1600. The subindices for 0x1018 are expanded.

Data management and function "NoCoeStorage"

Some parameters, particularly the setting parameters of the slave, are configurable and writeable. This can be done in write or read mode

- via the System Manager (Fig. "CoE Online " tab) by clicking
This is useful for commissioning of the system/slaves. Click on the row of the index to be parameterised and enter a value in the "SetValue" dialog.
- from the control system/PLC via ADS, e.g. through blocks from the TcEtherCAT.lib library
This is recommended for modifications while the system is running or if no System Manager or operating staff are available.

i
Note

Data management

If slave CoE parameters are modified online, Beckhoff devices store any changes in a fail-safe manner in the EEPROM, i.e. the modified CoE parameters are still available after a restart.
The situation may be different with other manufacturers.

An EEPROM is subject to a limited lifetime with respect to write operations. From typically 100,000 write operations onwards it can no longer be guaranteed that new (changed) data are reliably saved or are still readable. This is irrelevant for normal commissioning. However, if CoE parameters are continuously changed via ADS at machine runtime, it is quite possible for the lifetime limit to be reached. Support for the NoCoeStorage function, which suppresses the saving of changed CoE values, depends on the firmware version. Please refer to the technical data in this documentation as to whether this applies to the respective device.

- If the function is supported: the function is activated by entering the code word 0x12345678 once in CoE 0xF008 and remains active as long as the code word is not changed. After switching the device on it is then inactive. Changed CoE values are not saved in the EEPROM and can thus be changed any number of times.
- Function is not supported: continuous changing of CoE values is not permissible in view of the lifetime limit.

i
Note

Startup list

Changes in the local CoE list of the terminal are lost if the terminal is replaced. If a terminal is replaced with a new Beckhoff terminal, it will have the default settings. It is therefore advisable to link all changes in the CoE list of an EtherCAT slave with the Startup list of the slave, which is processed whenever the EtherCAT fieldbus is started. In this way a replacement EtherCAT slave can automatically be parameterized with the specifications of the user.

If EtherCAT slaves are used which are unable to store local CoE values permanently, the Startup list must be used.

Recommended approach for manual modification of CoE parameters

- Make the required change in the System Manager
The values are stored locally in the EtherCAT slave
- If the value is to be stored permanently, enter it in the Startup list.
The order of the Startup entries is usually irrelevant.

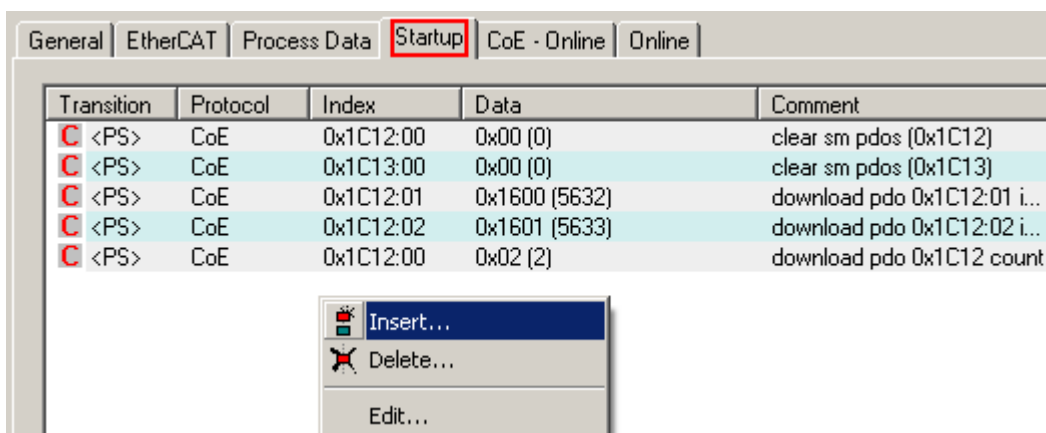

Fig. 15: Startup list in the TwinCAT System Manager

The Startup list may already contain values that were configured by the System Manager based on the ESI specifications. Additional application-specific entries can be created.

Online/offline list

While working with the TwinCAT System Manager, a distinction has to be made whether the EtherCAT device is "available", i.e. switched on and linked via EtherCAT and therefore **online**, or whether a configuration is created **offline** without connected slaves.

In both cases a CoE list as shown in Fig. "CoE online' tab" is displayed. The connectivity is shown as offline/online.

- If the slave is offline
 - The offline list from the ESI file is displayed. In this case modifications are not meaningful or possible.
 - The configured status is shown under Identity.
 - No firmware or hardware version is displayed, since these are features of the physical device.
 - **Offline** is shown in red.

Index	Name	Flags	Value
1000	Device type	RO	0x00FA1389 (16389001)
1008	Device name	RO	EL2502-0000
1009	Hardware version	RO	
100A	Software version	RO	
1011:0	Restore default parameters	RO	> 1 <
1018:0	Identity	RO	> 4 <
1018:01	Vendor ID	RO	0x00000002 (2)
1018:02	Product code	RO	0x09C63052 (163983442)
1018:03	Revision	RO	0x00130000 (1245184)
1018:04	Serial number	RO	0x00000000 (0)
10F0:0	Backup parameter handling	RO	> 1 <
1400:0	PWM RxPDO-Par Ch.1	RO	> 6 <
1401:0	PWM RxPDO-Par Ch.2	RO	> 6 <
1402:0	PWM RxPDO-Par h.1 Ch.1	RO	> 6 <
1403:0	PWM RxPDO-Par h.1 Ch.2	RO	> 6 <
1600:0	PWM RxPDO-Map Ch.1	RO	> 1 <

Fig. 16: Offline list

- If the slave is online
 - The actual current slave list is read. This may take several seconds, depending on the size and cycle time.
 - The actual identity is displayed
 - The firmware and hardware version of the equipment according to the electronic information is displayed
 - **Online** is shown in green.

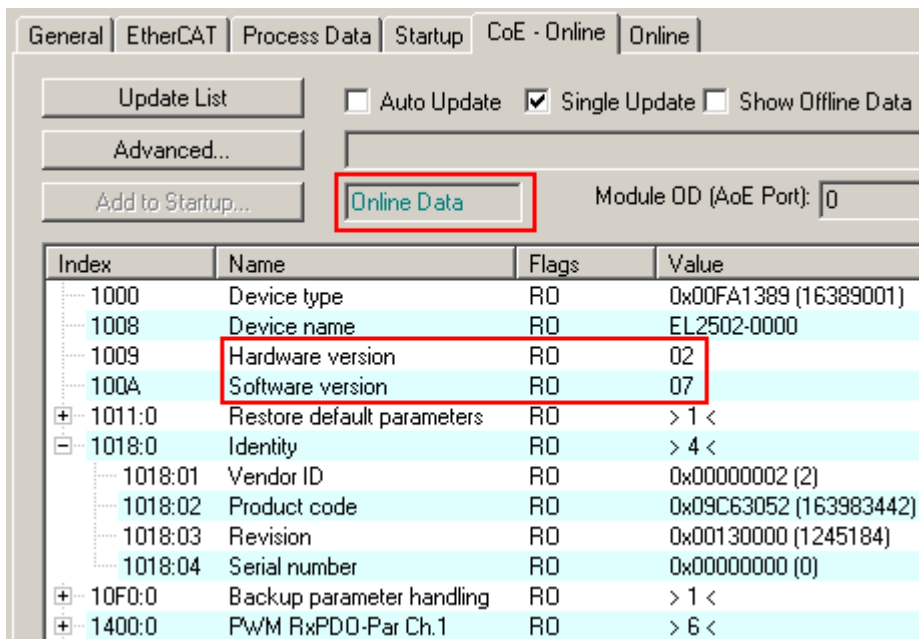

Fig. 17: Online list

Channel-based order

The CoE list is available in EtherCAT devices that usually feature several functionally equivalent channels. For example, a 4-channel analog 0..10 V input terminal also has 4 logical channels and therefore 4 identical sets of parameter data for the channels. In order to avoid having to list each channel in the documentation, the placeholder "n" tends to be used for the individual channel numbers.

In the CoE system 16 indices, each with 255 subindices, are generally sufficient for representing all channel parameters. The channel-based order is therefore arranged in $16_{dec}/10_{hex}$ steps. The parameter range 0x8000 exemplifies this:

- Channel 0: parameter range 0x8000:00 ... 0x800F:255
- Channel 1: parameter range 0x8010:00 ... 0x801F:255
- Channel 2: parameter range 0x8020:00 ... 0x802F:255
- ...

This is generally written as 0x80n0.

Detailed information on the CoE interface can be found in the [EtherCAT system documentation](#) on the Beckhoff website.

4.6 Distributed Clock

The distributed clock represents a local clock in the EtherCAT slave controller (ESC) with the following characteristics:

- Unit *1 ns*
- Zero point *1.1.2000 00:00*
- Size *64 bit* (sufficient for the next 584 years; however, some EtherCAT slaves only offer 32-bit support, i.e. the variable overflows after approx. 4.2 seconds)
- The EtherCAT master automatically synchronizes the local clock with the master clock in the EtherCAT bus with a precision of < 100 ns.

For detailed information please refer to the [EtherCAT system description](#).

5 Mounting and wiring

5.1 Instructions for ESD protection

	<p>Destruction of the devices by electrostatic discharge possible!</p> <p>The devices contain components at risk from electrostatic discharge caused by improper handling.</p> <ul style="list-style-type: none"> ✓ Please ensure you are electrostatically discharged and avoid touching the contacts of the device directly. a) Avoid contact with highly insulating materials (synthetic fibers, plastic film etc.). b) Surroundings (working place, packaging and personnel) should be grounded probably, when handling with the devices. c) Each assembly must be terminated at the right hand end with an EL9011 bus end cap, to ensure the protection class and ESD protection.
<p>Attention</p>	

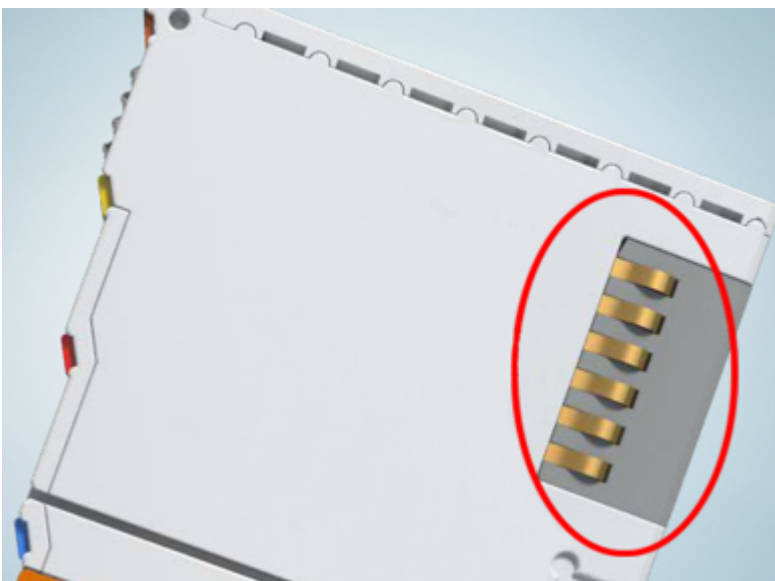



Fig. 18: Spring contacts of the Beckhoff I/O components

5.2 Installation on mounting rails

	<p>Risk of electric shock and damage of device!</p> <p>Bring the bus terminal system into a safe, powered down state before starting installation, disassembly or wiring of the Bus Terminals!</p>
<p>WARNING</p>	

Assembly

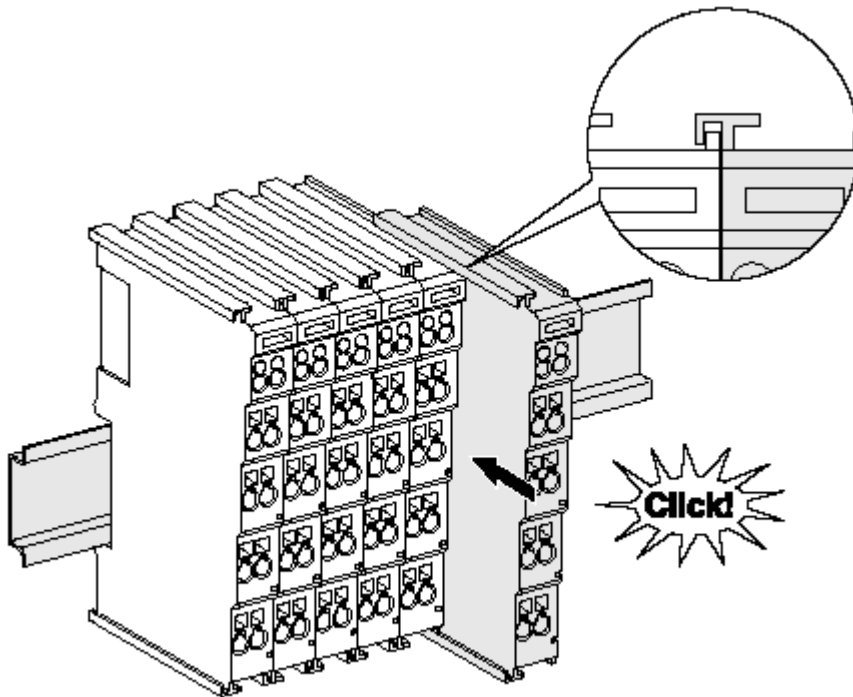

Fig. 19: Attaching on mounting rail

The Bus Coupler and Bus Terminals are attached to commercially available 35 mm mounting rails (DIN rails according to EN 60715) by applying slight pressure:

1. First attach the Fieldbus Coupler to the mounting rail.
2. The Bus Terminals are now attached on the right-hand side of the Fieldbus Coupler. Join the components with tongue and groove and push the terminals against the mounting rail, until the lock clicks onto the mounting rail.

If the Terminals are clipped onto the mounting rail first and then pushed together without tongue and groove, the connection will not be operational! When correctly assembled, no significant gap should be visible between the housings.

**Note****Fixing of mounting rails**

The locking mechanism of the terminals and couplers extends to the profile of the mounting rail. At the installation, the locking mechanism of the components must not come into conflict with the fixing bolts of the mounting rail. To mount the mounting rails with a height of 7.5 mm under the terminals and couplers, you should use flat mounting connections (e.g. countersunk screws or blind rivets).

Disassembly

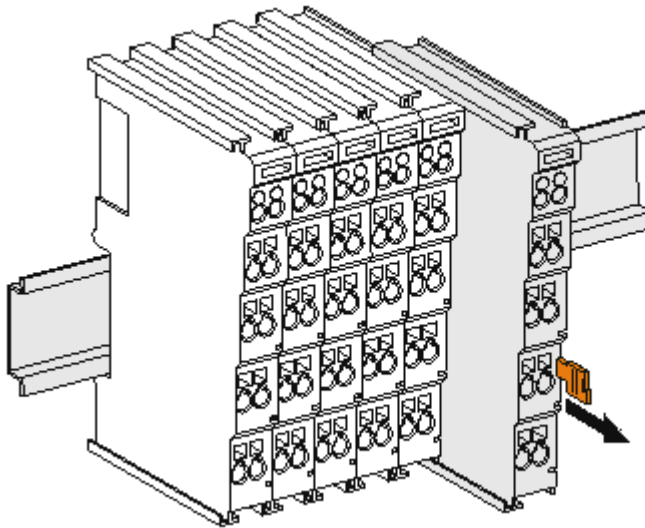

Fig. 20: Disassembling of terminal

Each terminal is secured by a lock on the mounting rail, which must be released for disassembly:

1. Pull the terminal by its orange-colored lugs approximately 1 cm away from the mounting rail. In doing so for this terminal the mounting rail lock is released automatically and you can pull the terminal out of the bus terminal block easily without excessive force.
2. Grasp the released terminal with thumb and index finger simultaneous at the upper and lower grooved housing surfaces and pull the terminal out of the bus terminal block.

Connections within a bus terminal block

The electric connections between the Bus Coupler and the Bus Terminals are automatically realized by joining the components:

- The six spring contacts of the K-Bus/E-Bus deal with the transfer of the data and the supply of the Bus Terminal electronics.
- The power contacts deal with the supply for the field electronics and thus represent a supply rail within the bus terminal block. The power contacts are supplied via terminals on the Bus Coupler (up to 24 V) or for higher voltages via power feed terminals.



Note

Power Contacts

During the design of a bus terminal block, the pin assignment of the individual Bus Terminals must be taken account of, since some types (e.g. analog Bus Terminals or digital 4-channel Bus Terminals) do not or not fully loop through the power contacts. Power Feed Terminals (KL91xx, KL92xx or EL91xx, EL92xx) interrupt the power contacts and thus represent the start of a new supply rail.

PE power contact

The power contact labeled PE can be used as a protective earth. For safety reasons this contact mates first when plugging together, and can ground short-circuit currents of up to 125 A.

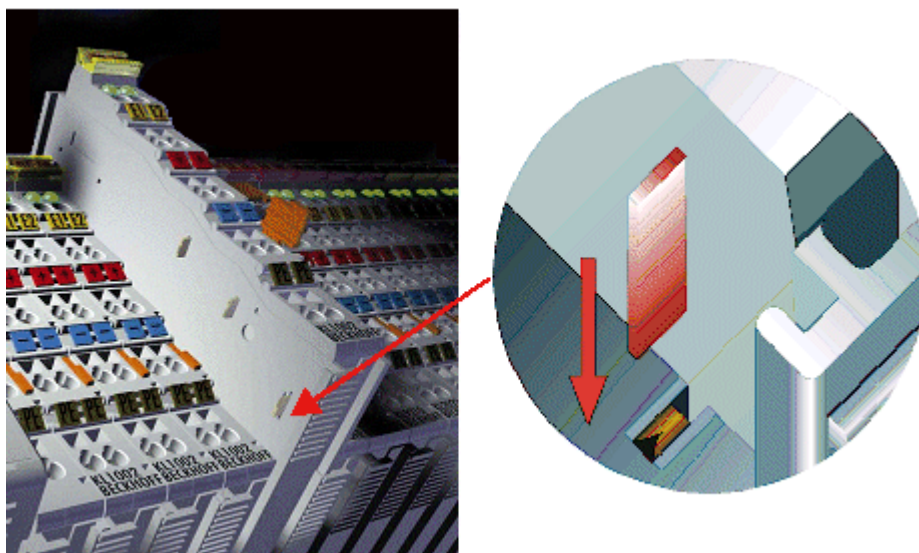





Fig. 21: Power contact on left side

 Attention	<p>Possible damage of the device</p> <p>Note that, for reasons of electromagnetic compatibility, the PE contacts are capacitatively coupled to the mounting rail. This may lead to incorrect results during insulation testing or to damage on the terminal (e.g. disruptive discharge to the PE line during insulation testing of a consumer with a nominal voltage of 230 V). For insulation testing, disconnect the PE supply line at the Bus Coupler or the Power Feed Terminal! In order to decouple further feed points for testing, these Power Feed Terminals can be released and pulled at least 10 mm from the group of terminals.</p>
---	---

 WARNING	<p>Risk of electric shock!</p> <p>The PE power contact must not be used for other potentials!</p>
---	--

5.3 Installation instructions for enhanced mechanical load capacity

 WARNING	<p>Risk of injury through electric shock and damage to the device!</p> <p>Bring the Bus Terminal system into a safe, de-energized state before starting mounting, disassembly or wiring of the Bus Terminals!</p>
---	--

Additional checks

The terminals have undergone the following additional tests:

Verification	Explanation
Vibration	10 frequency runs in 3 axes
	6 Hz < f < 60 Hz displacement 0.35 mm, constant amplitude
	60.1 Hz < f < 500 Hz acceleration 5 g, constant amplitude
Shocks	1000 shocks in each direction, in 3 axes
	25 g, 6 ms

Additional installation instructions

For terminals with enhanced mechanical load capacity, the following additional installation instructions apply:

- The enhanced mechanical load capacity is valid for all permissible installation positions
- Use a mounting rail according to EN 60715 TH35-15
- Fix the terminal segment on both sides of the mounting rail with a mechanical fixture, e.g. an earth terminal or reinforced end clamp
- The maximum total extension of the terminal segment (without coupler) is: 64 terminals (12 mm mounting with) or 32 terminals (24 mm mounting with)
- Avoid deformation, twisting, crushing and bending of the mounting rail during edging and installation of the rail
- The mounting points of the mounting rail must be set at 5 cm intervals
- Use countersunk head screws to fasten the mounting rail
- The free length between the strain relief and the wire connection should be kept as short as possible. A distance of approx. 10 cm should be maintained to the cable duct.

5.4 Connection

5.4.1 Connection system

	<p>Risk of electric shock and damage of device!</p> <p>Bring the bus terminal system into a safe, powered down state before starting installation, disassembly or wiring of the Bus Terminals!</p>
<p>WARNING</p>	

Overview

The Bus Terminal system offers different connection options for optimum adaptation to the respective application:

- The terminals of ELxxxx and KLxxxx series with standard wiring include electronics and connection level in a single enclosure.
- The terminals of ESxxxx and KSxxxx series feature a pluggable connection level and enable steady wiring while replacing.
- The High Density Terminals (HD Terminals) include electronics and connection level in a single enclosure and have advanced packaging density.

Standard wiring (ELxxxx / KLxxxx)



Fig. 22: Standard wiring

The terminals of ELxxxx and KLxxxx series have been tried and tested for years. They feature integrated screwless spring force technology for fast and simple assembly.

Pluggable wiring (ESxxxx / KSxxxx)

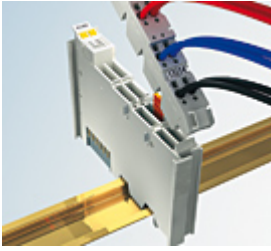

Fig. 23: Pluggable wiring

The terminals of ESxxxx and KSxxxx series feature a pluggable connection level. The assembly and wiring procedure is the same as for the ELxxxx and KLxxxx series. The pluggable connection level enables the complete wiring to be removed as a plug connector from the top of the housing for servicing. The lower section can be removed from the terminal block by pulling the unlocking tab. Insert the new component and plug in the connector with the wiring. This reduces the installation time and eliminates the risk of wires being mixed up.

The familiar dimensions of the terminal only had to be changed slightly. The new connector adds about 3 mm. The maximum height of the terminal remains unchanged.

A tab for strain relief of the cable simplifies assembly in many applications and prevents tangling of individual connection wires when the connector is removed.

Conductor cross sections between 0.08 mm² and 2.5 mm² can continue to be used with the proven spring force technology.

The overview and nomenclature of the product names for ESxxxx and KSxxxx series has been retained as known from ELxxxx and KLxxxx series.

High Density Terminals (HD Terminals)



Fig. 24: High Density Terminals

The Bus Terminals from these series with 16 terminal points are distinguished by a particularly compact design, as the packaging density is twice as large as that of the standard 12 mm Bus Terminals. Massive conductors and conductors with a wire end sleeve can be inserted directly into the spring loaded terminal point without tools.

 Note	<p>Wiring HD Terminals</p> <p>The High Density (HD) Terminals of the ELx8xx and KLx8xx series doesn't support pluggable wiring.</p>
--	--

Ultrasonically "bonded" (ultrasonically welded) conductors

 Note	<p>Ultrasonically "bonded" conductors</p> <p>It is also possible to connect the Standard and High Density Terminals with ultrasonically "bonded" (ultrasonically welded) conductors. In this case, please note the tables concerning the wire-size width below!</p>
--	--

5.4.2 Wiring

 WARNING	<p>Risk of electric shock and damage of device!</p> <p>Bring the bus terminal system into a safe, powered down state before starting installation, disassembly or wiring of the Bus Terminals!</p>
---	---

Terminals for standard wiring ELxxxx/KLxxxx and for pluggable wiring ESxxxx/KSxxxx

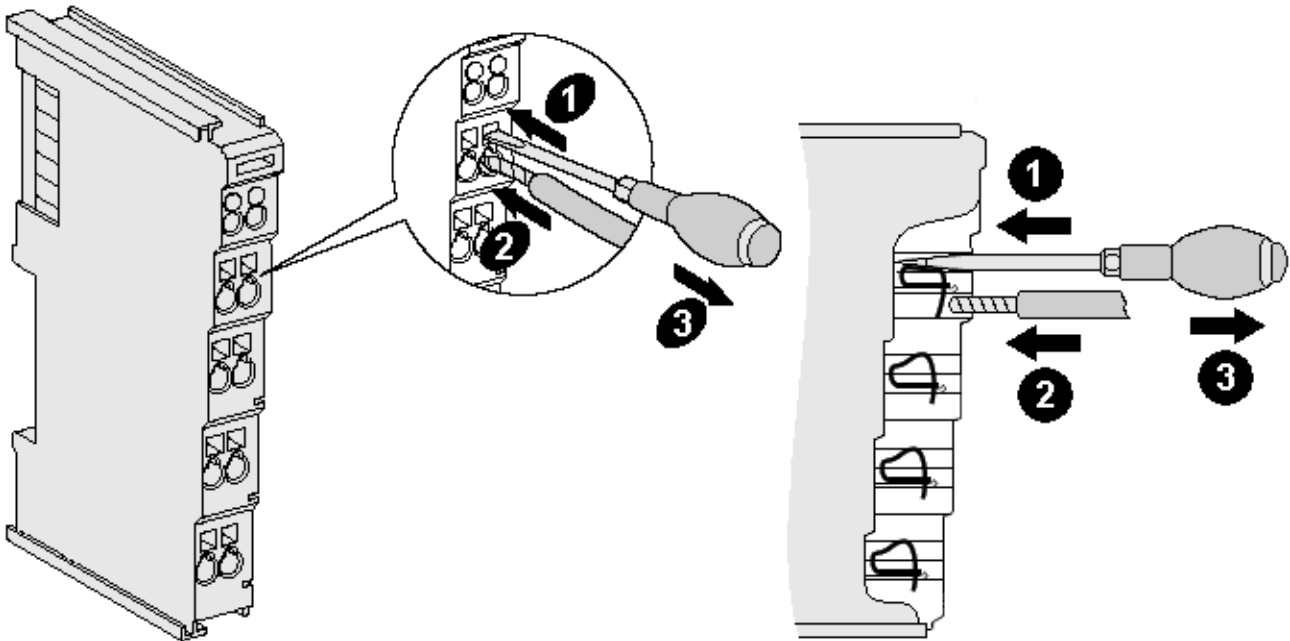

Fig. 25: Connecting a cable on a terminal point

Up to eight terminal points enable the connection of solid or finely stranded cables to the Bus Terminal. The terminal points are implemented in spring force technology. Connect the cables as follows:

1. Open a terminal point by pushing a screwdriver straight against the stop into the square opening above the terminal point. Do not turn the screwdriver or move it alternately (don't toggle).
2. The wire can now be inserted into the round terminal opening without any force.
3. The terminal point closes automatically when the pressure is released, holding the wire securely and permanently.

See the following table for the suitable wire size width.

Terminal housing	ELxxxx, KLxxxx	ESxxxx, KSxxxx
Wire size width (single core wires)	0.08 ... 2.5 mm ²	0.08 ... 2.5 mm ²
Wire size width (fine-wire conductors)	0.08 ... 2.5 mm ²	0,08 ... 2.5 mm ²
Wire size width (conductors with a wire end sleeve)	0.14 ... 1.5 mm ²	0.14 ... 1.5 mm ²
Wire stripping length	8 ... 9 mm	9 ... 10 mm

High Density Terminals ([HD Terminals](#) [► 34]) with 16 terminal points

The conductors of the HD Terminals are connected without tools for single-wire conductors using the direct plug-in technique, i.e. after stripping the wire is simply plugged into the terminal point. The cables are released, as usual, using the contact release with the aid of a screwdriver. See the following table for the suitable wire size width.

Terminal housing	High Density Housing
Wire size width (single core wires)	0.08 ... 1.5 mm ²
Wire size width (fine-wire conductors)	0.25 ... 1.5 mm ²
Wire size width (conductors with a wire end sleeve)	0.14 ... 0.75 mm ²
Wire size width (ultrasonically "bonded" conductors)	only 1.5 mm ²
Wire stripping length	8 ... 9 mm

5.4.3 Shielding

 Note	<p>Shielding</p> <p>Encoder, analog sensors and actors should always be connected with shielded, twisted paired wires.</p>
--	---

5.5 Positioning of passive Terminals

 Note	<p>Hint for positioning of passive terminals in the bus terminal block</p> <p>EtherCAT Terminals (ELxxxx / ESxxxx), which do not take an active part in data transfer within the bus terminal block are so called passive terminals. The passive terminals have no current consumption out of the E-Bus.</p> <p>To ensure an optimal data transfer, you must not directly string together more than 2 passive terminals!</p>
--	---

Examples for positioning of passive terminals (highlighted)

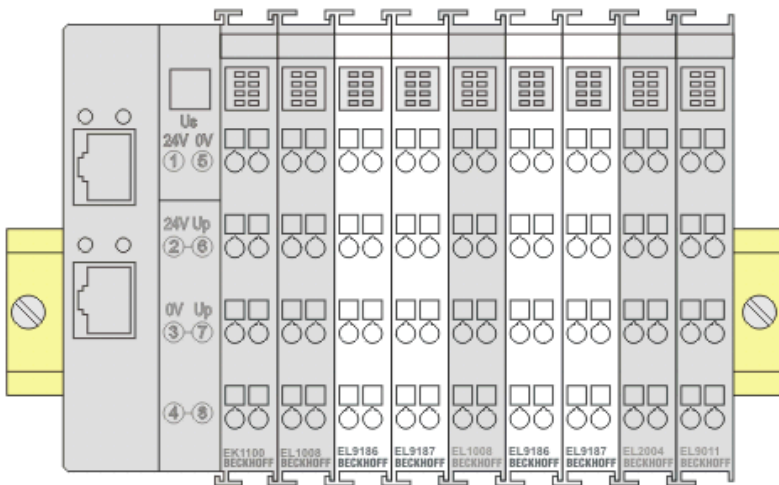

Fig. 26: Correct positioning

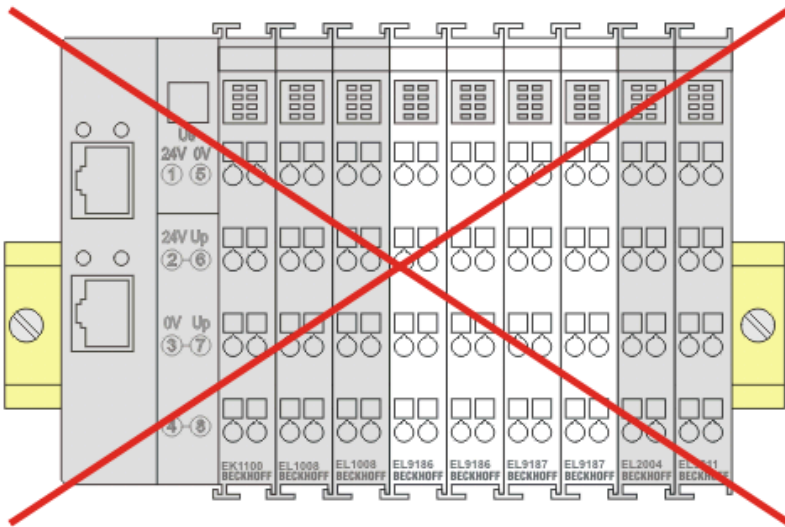

Fig. 27: Incorrect positioning

5.6 Installation positions



Attention

Constraints regarding installation position and operating temperature range

Please refer to the technical data for a terminal to ascertain whether any restrictions regarding the installation position and/or the operating temperature range have been specified. When installing high power dissipation terminals ensure that an adequate spacing is maintained between other components above and below the terminal in order to guarantee adequate ventilation!

Optimum installation position (standard)

The optimum installation position requires the mounting rail to be installed horizontally and the connection surfaces of the EL/KL terminals to face forward (see Fig. "Recommended distances for standard installation position"). The terminals are ventilated from below, which enables optimum cooling of the electronics through convection. "From below" is relative to the acceleration of gravity.

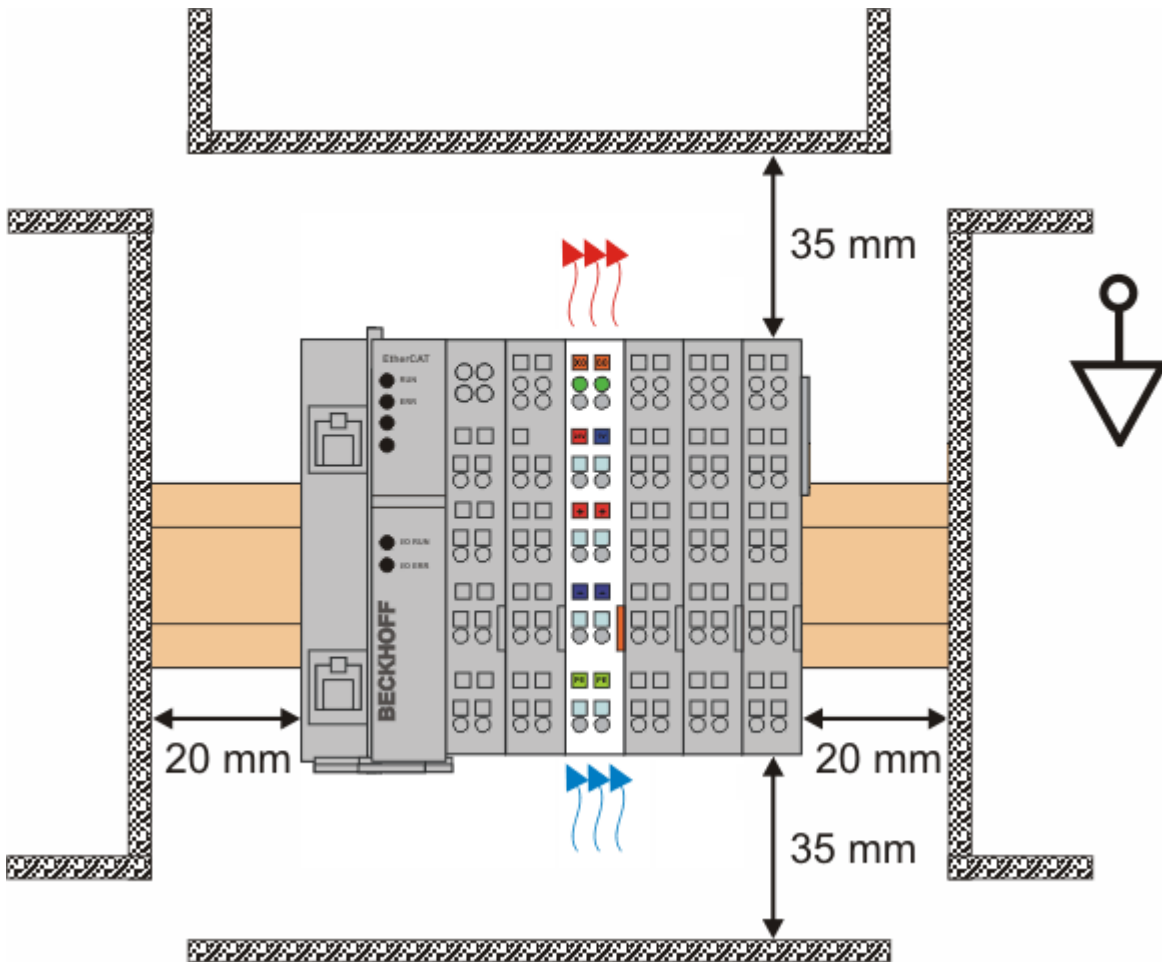

Fig. 28: Recommended distances for standard installation position

Compliance with the distances shown in Fig. “Recommended distances for standard installation position” is recommended.

Other installation positions

All other installation positions are characterized by different spatial arrangement of the mounting rail - see Fig “Other installation positions”.

The minimum distances to ambient specified above also apply to these installation positions.

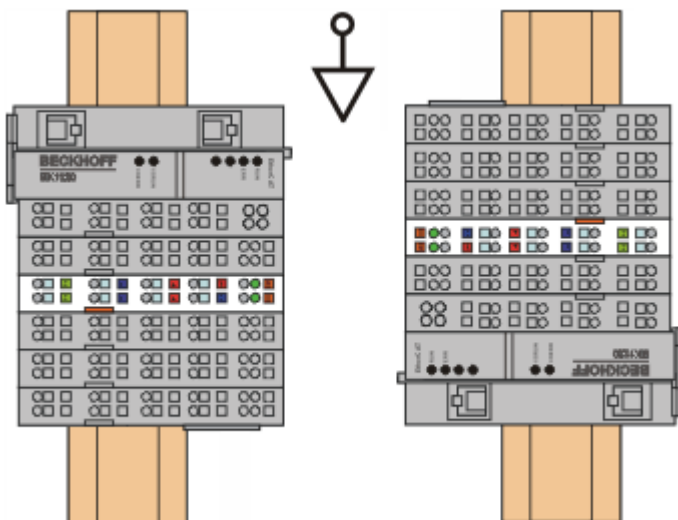

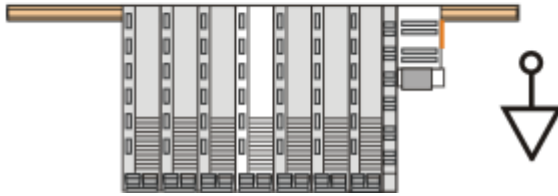



Fig. 29: *Other installation positions*

5.7 Connection assignment

WARNING  **Caution: Risk of electric shock!**
 If you do not connect the terminal point N with the neutral conductor of your mains supply (e.g. if the EL3773 is used purely for current measurements), terminal point N should be earthed, in order to avoid dangerous overvoltages in the event of a current transformer fault!

WARNING  **Caution: Risk of electric shock!**
 Please note that many manufacturers do not permit their current transformers to be operated in no-load mode! Connect the EL3773 to the secondary windings of the current transformers before using the current transformer!

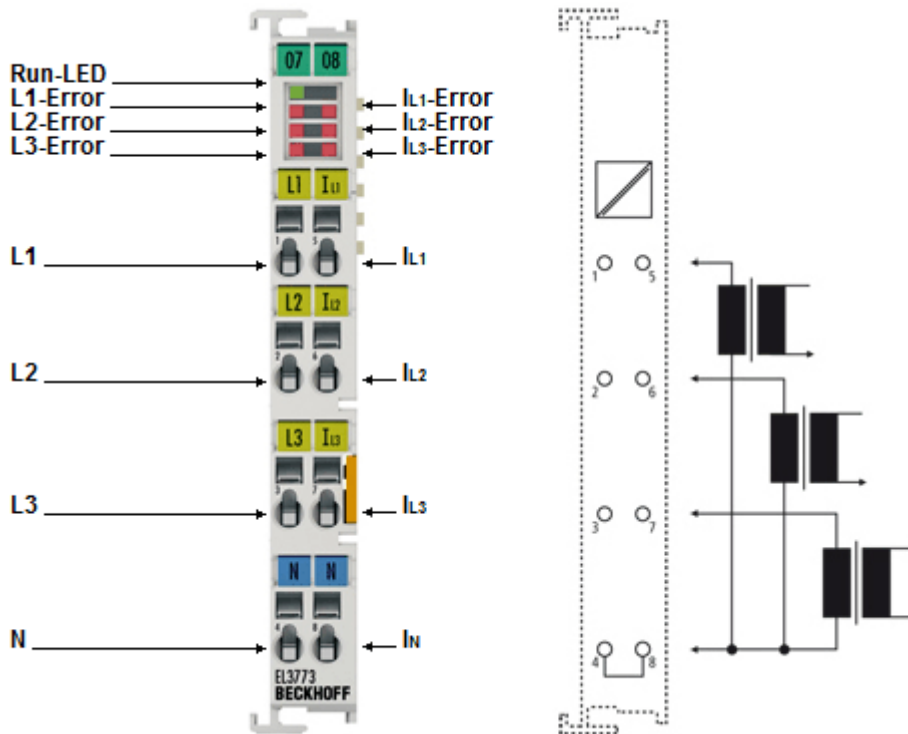

Fig. 30: EL3773

Connection

Terminal point		Description	Comment
Name	No.		
L1	1	Phase L1	Connections for the voltage measurement. Please observe the notes [► 40] .
L2	2	Phase L2	
L3	3	Phase L3	
N	4	Neutral conductor N (internally connected to terminal point I _N , capacitively connected to the earthing contact to the mounting rail)	
IL1	5	Consumer at phase L1	Connections for the current transformers. Please observe the notes [► 40] .
IL2	6	Consumer at phase L2	
IL3	7	Consumer at phase L3	
IN	8	Star point of the current transformers (internally connected to terminal point N, capacitively connected to the earthing contact to the mounting rail)	

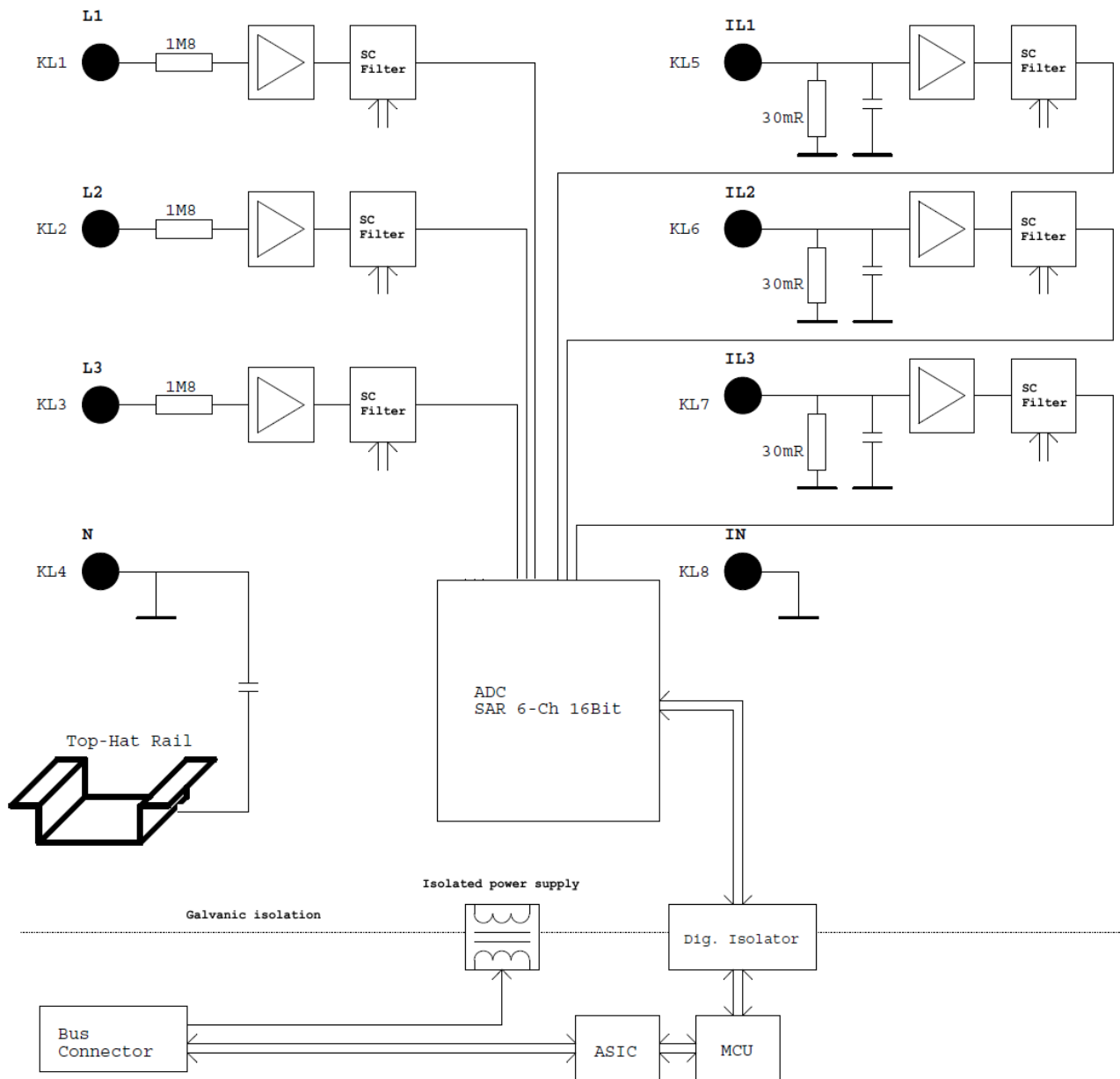

Fig. 31: Block diagram

6 Commissioning

6.1 Quick start

Quick start

No special measures are required for the initial commissioning of the EL3773.

The EL3773 can be operated with different types of function. The course of decision making and action of the commissioning is shown below.

The introductory chapters on

- [Technology](#) [▶ 16]
- [Method of operation](#) [▶ 85]
- [Application notes](#) [▶ 102]
- [Example programs](#) [▶ 135]

are to be observed for understanding.

1. Mounting

Install the EL3773 as described in chapter [Mounting and wiring](#) [▶ 29].

2. Configuration

Create a configuration in the TwinCAT System Manager by manually inserting the terminal or scanning it online. Refer to installation chapter TwinCAT 2.x regarding this.



Note

EtherCAT XML Device Description

If the XML description of the EL3773 is not available in your system you can download the latest XML file from the download area of the [Beckhoff website](#) and install it according to the installation instructions.

3. Delivery state

The EL3773 is inserted by default in the TwinCAT System Manager with the following settings

- Trigger activated by Distributed Clocks
- 10-fold oversampling

4. Setting the parameters and process data

Distributed Clocks

Deactivate Distributed Clocks if necessary. This is recommended only if the EtherCAT system is to be operated without Distributed Clocks functionality.

Oversampling factor

Specify the oversampling factor within the range of permissible values.

CoE parameters

If the default CoE parameters are to be changed, they must be saved for each channel in the CoE.

**Note****Parameterization via the CoE list (CAN over EtherCAT)**

The terminal is parameterized via the CoE - Online tab (double-click on the respective object) or via the Process Data tab (allocation of PDOs).

Please note the following general [CoE notes](#) [▶ 23] when using/manipulating the CoE parameters:

- Keep a **startup** list if components have to be replaced
- Differentiation between online/offline dictionary, existence of current XML description
- use "CoE reload" for resetting changes

The CoE settings can also be loaded via the SPS/PLC/Task at runtime.

5. Operation

With voltage/current present, the measured values are now transmitted via the process data, for example in the TwinCAT free-run mode, after restarting TwinCAT.

**Note****Data visualization with TwinCAT Scope2**

The TwinCAT Scope2 supports the import of oversampling variables in the case of the EL3773 as well. Please observe the corresponding notes for this.

6.2 TwinCAT Development Environment

The Software for automation TwinCAT (The Windows Control and Automation Technology) will be distinguished into:

- TwinCAT 2: System Manager (Configuration) & PLC Control (Programming)
- TwinCAT 3: Enhancement of TwinCAT 2 (Programming and Configuration takes place via a common Development Environment)

Details:

- **TwinCAT 2:**
 - Connects I/O devices to tasks in a variable-oriented manner
 - Connects tasks to tasks in a variable-oriented manner
 - Supports units at the bit level
 - Supports synchronous or asynchronous relationships
 - Exchange of consistent data areas and process images
 - Datalink on NT - Programs by open Microsoft Standards (OLE, OCX, ActiveX, DCOM+, etc.)
 - Integration of IEC 61131-3-Software-SPS, Software- NC and Software-CNC within Windows NT/2000/XP/Vista, Windows 7, NT/XP Embedded, CE
 - Interconnection to all common fieldbusses
 - [More...](#)

Additional features:

- **TwinCAT 3 (eXtended Automation):**
 - Visual-Studio®-Integration
 - Choice of the programming language
 - Supports object orientated extension of IEC 61131-3
 - Usage of C/C++ as programming language for real time applications
 - Connection to MATLAB®/Simulink®
 - Open interface for expandability
 - Flexible run-time environment
 - Active support of Multi-Core- und 64-Bit-Operatingsystem

- Automatic code generation and project creation with the TwinCAT Automation Interface
- More...

Within the following sections commissioning of the TwinCAT Development Environment on a PC System for the control and also the basically functions of unique control elements will be explained.

Please see further information to TwinCAT 2 and TwinCAT 3 at <http://infosys.beckhoff.com>.

6.2.1 Installation of the TwinCAT real-time driver

In order to assign real-time capability to a standard Ethernet port of an IPC controller, the Beckhoff real-time driver has to be installed on this port under Windows.

This can be done in several ways. One option is described here.

In the System Manager call up the TwinCAT overview of the local network interfaces via Options → Show Real Time Ethernet Compatible Devices.

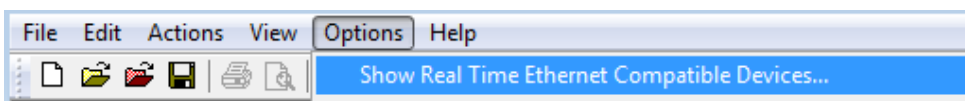

Fig. 32: System Manager "Options" (TwinCAT 2)

This have to be called up by the Menü "TwinCAT" within the TwinCAT 3 environment:

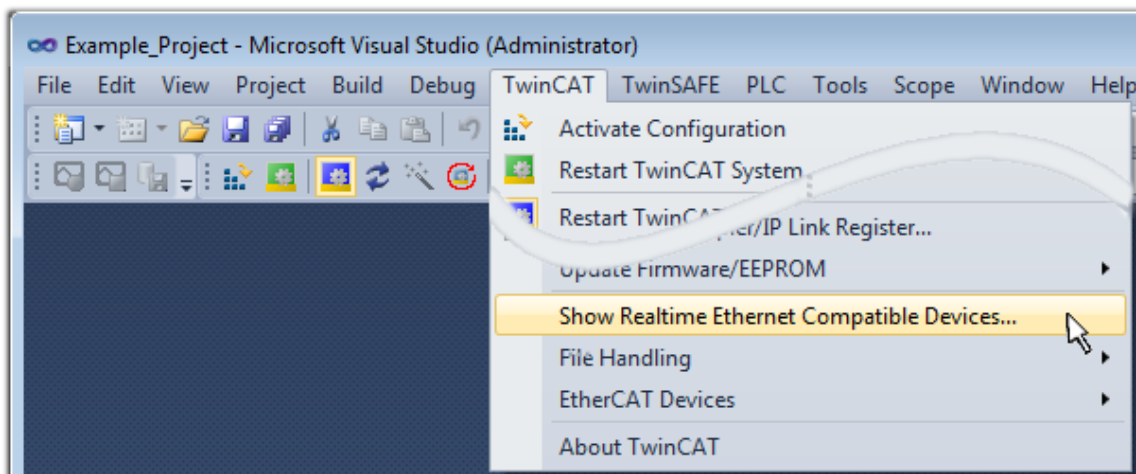

Fig. 33: Call up under VS Shell (TwinCAT 3)

The following dialog appears:

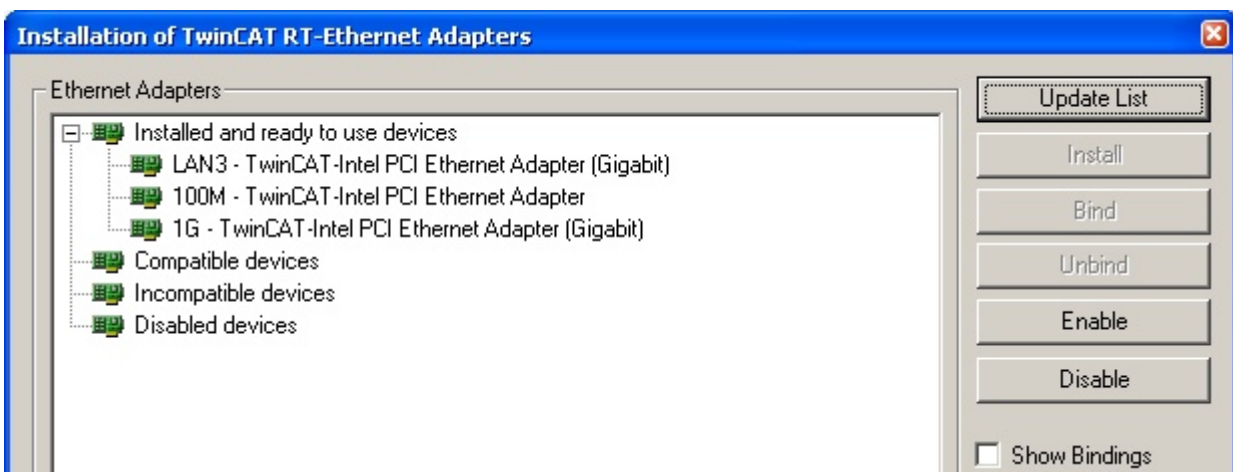

Fig. 34: Overview of network interfaces

Interfaces listed under “Compatible devices” can be assigned a driver via the “Install” button. A driver should only be installed on compatible devices.

A Windows warning regarding the unsigned driver can be ignored.

Alternatively an EtherCAT-device can be inserted first of all as described in chapter [Offline configuration creation, section “Creating the EtherCAT device” \[▶ 54\]](#) in order to view the compatible ethernet ports via its EtherCAT properties (tab „Adapter“, button „Compatible Devices...“):



Fig. 35: EtherCAT device properties(TwinCAT 2): click on „Compatible Devices...“ of tab “Adapter”

TwinCAT 3: the properties of the EtherCAT device can be opened by double click on “Device .. (EtherCAT)” within the Solution Explorer under “I/O”:

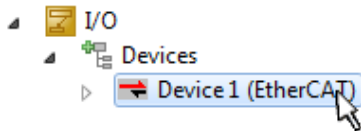

After the installation the driver appears activated in the Windows overview for the network interface (Windows Start → System Properties → Network)

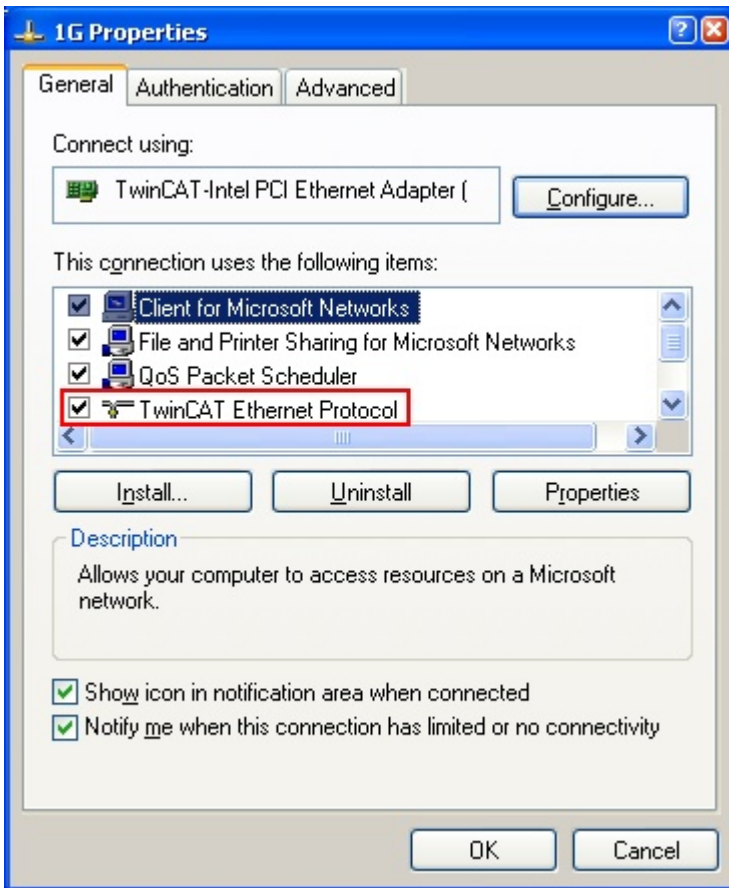

Fig. 36: *Windows properties of the network interface*

A correct setting of the driver could be:

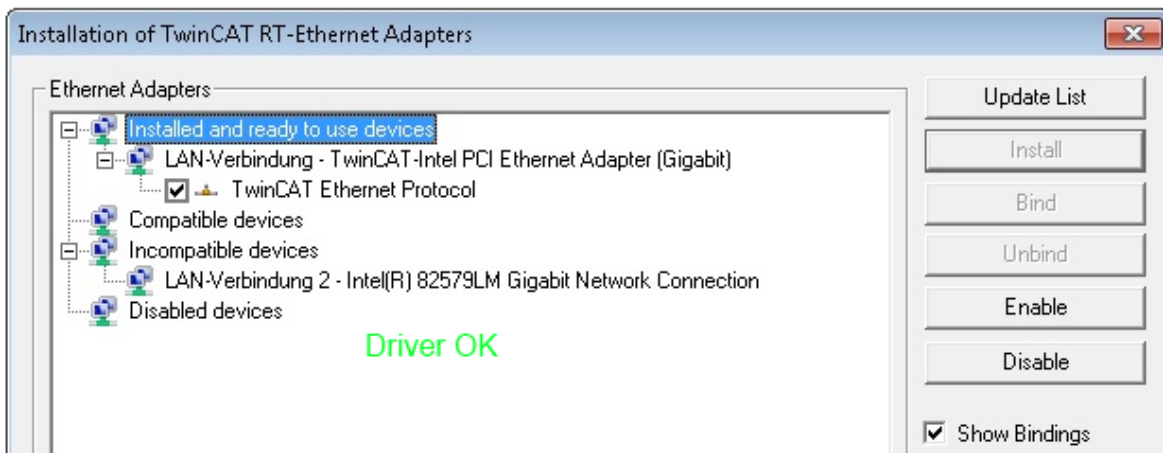

Fig. 37: *Exemplary correct driver setting for the Ethernet port*

Other possible settings have to be avoided:

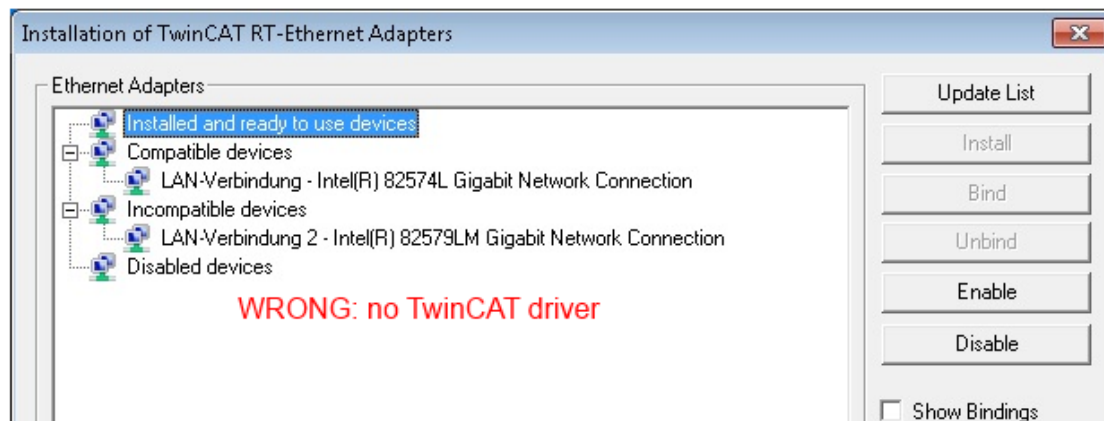
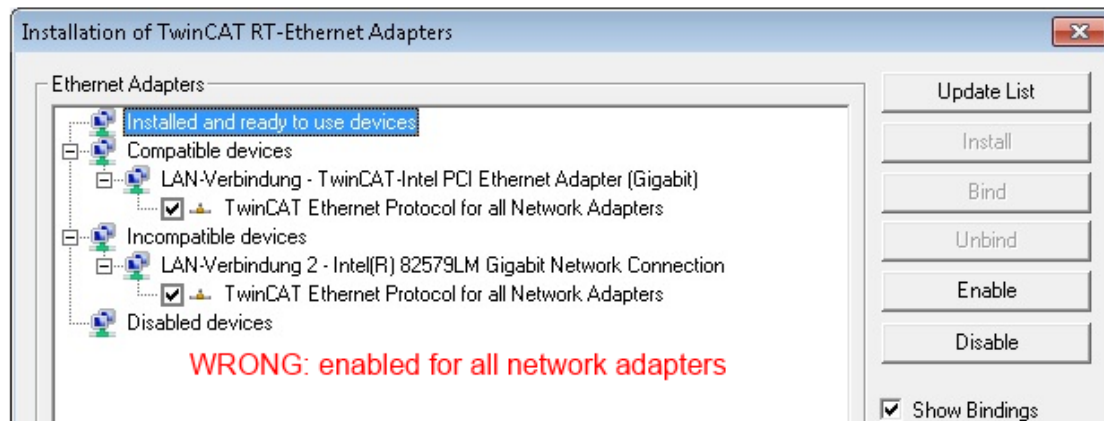
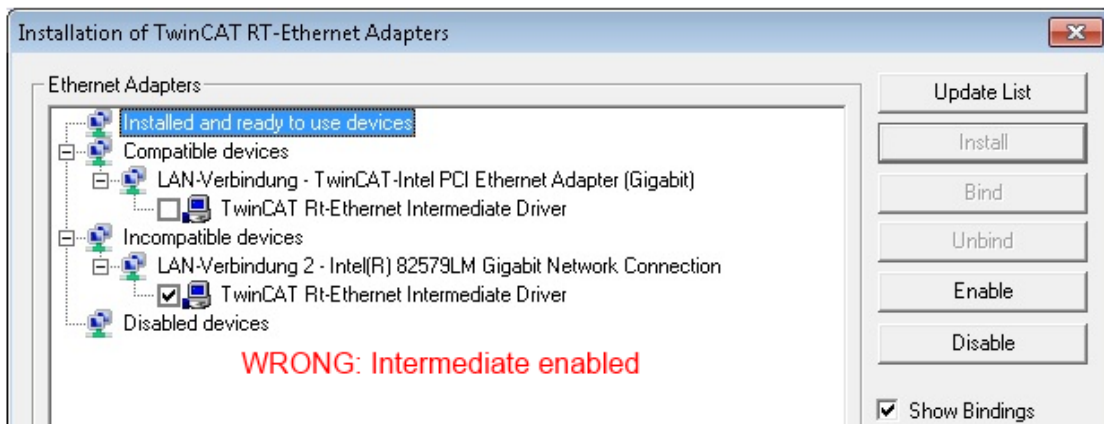
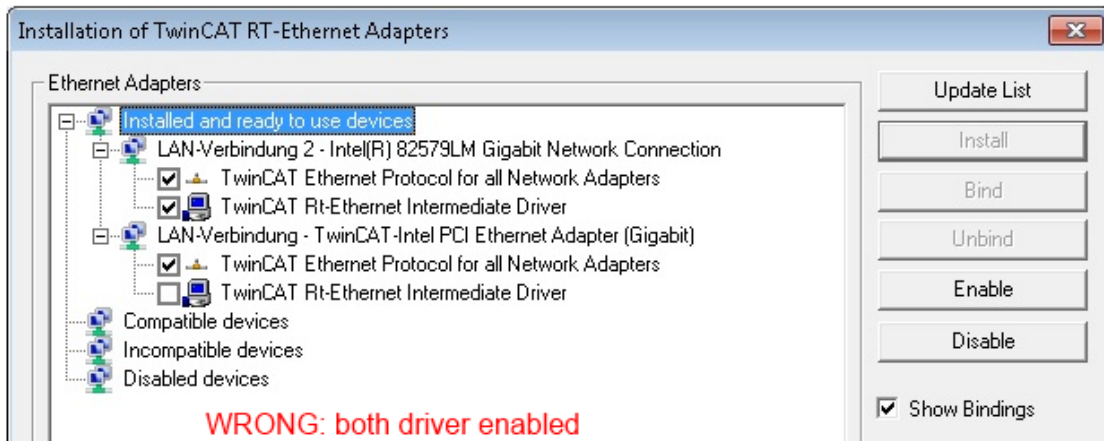

Fig. 38: Incorrect driver settings for the Ethernet port

IP address of the port used

**Note****IP address/DHCP**

In most cases an Ethernet port that is configured as an EtherCAT device will not transport general IP packets. For this reason and in cases where an EL6601 or similar devices are used it is useful to specify a fixed IP address for this port via the “Internet Protocol TCP/IP” driver setting and to disable DHCP. In this way the delay associated with the DHCP client for the Ethernet port assigning itself a default IP address in the absence of a DHCP server is avoided. A suitable address space is 192.168.x.x, for example.

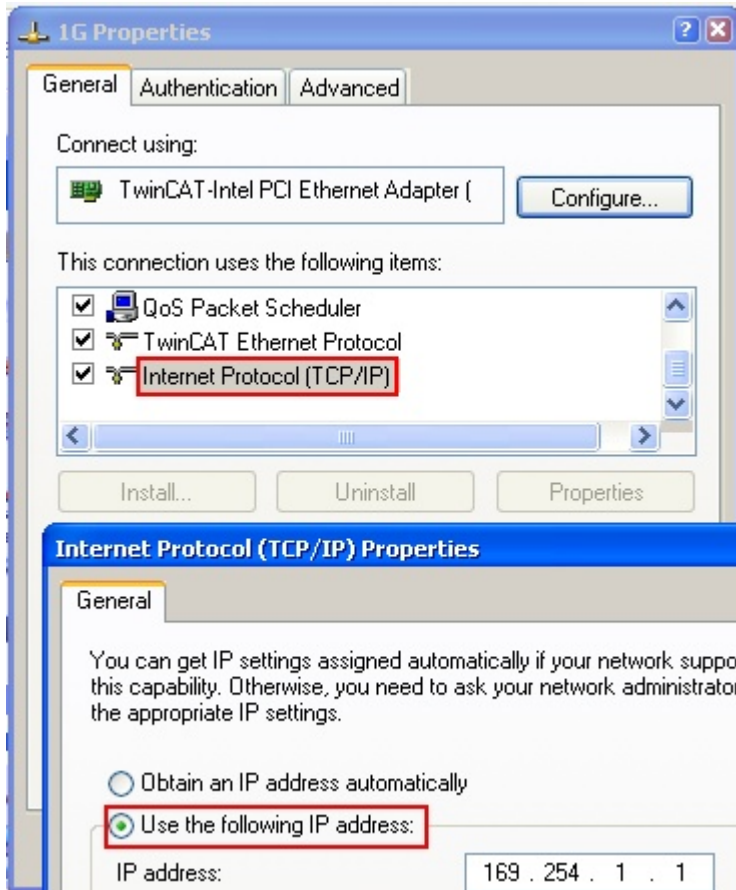

Fig. 39: TCP/IP setting for the Ethernet port

6.2.2 Notes regarding ESI device description

Installation of the latest ESI device description

The TwinCAT EtherCAT master/System Manager needs the device description files for the devices to be used in order to generate the configuration in online or offline mode. The device descriptions are contained in the so-called ESI files (EtherCAT Slave Information) in XML format. These files can be requested from the respective manufacturer and are made available for download. An *.xml file may contain several device descriptions.

The ESI files for Beckhoff EtherCAT devices are available on the [Beckhoff website](#).

The ESI files should be stored in the TwinCAT installation directory.

Default settings:

- **TwinCAT 2:** C:\TwinCAT\IO\EtherCAT
- **TwinCAT 3:** C:\TwinCAT\3.1\Config\Io\EtherCAT

The files are read (once) when a new System Manager window is opened, if they have changed since the last time the System Manager window was opened.

A TwinCAT installation includes the set of Beckhoff ESI files that was current at the time when the TwinCAT build was created.

For TwinCAT 2.11/TwinCAT 3 and higher, the ESI directory can be updated from the System Manager, if the programming PC is connected to the Internet; by

- **TwinCAT 2:** Option → “Update EtherCAT Device Descriptions”
- **TwinCAT 3:** TwinCAT → EtherCAT Devices → “Update Device Descriptions (via ETG Website)...”

The [TwinCAT ESI Updater \[► 53\]](#) is available for this purpose.

 Note	ESI The *.xml files are associated with *.xsd files, which describe the structure of the ESI XML files. To update the ESI device descriptions, both file types should therefore be updated.
--	---

Device differentiation

EtherCAT devices/slaves are distinguished by four properties, which determine the full device identifier. For example, the device identifier EL2521-0025-1018 consists of:

- family key “EL”
- name “2521”
- type “0025”
- and revision “1018”

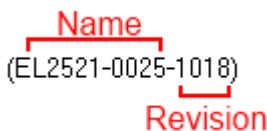

Fig. 40: Identifier structure

The order identifier consisting of name + type (here: EL2521-0010) describes the device function. The revision indicates the technical progress and is managed by Beckhoff. In principle, a device with a higher revision can replace a device with a lower revision, unless specified otherwise, e.g. in the documentation. Each revision has its own ESI description. See [further notes \[► 9\]](#).

Online description

If the EtherCAT configuration is created online through scanning of real devices (see section Online setup) and no ESI descriptions are available for a slave (specified by name and revision) that was found, the System Manager asks whether the description stored in the device should be used. In any case, the System Manager needs this information for setting up the cyclic and acyclic communication with the slave correctly.

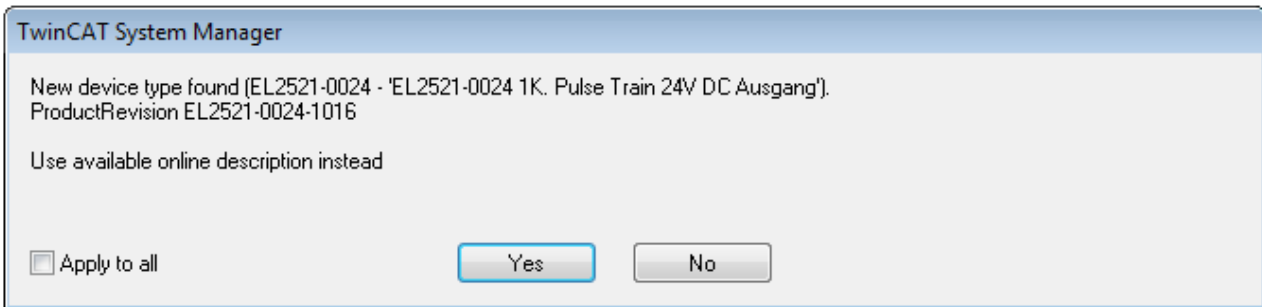

Fig. 41: *OnlineDescription information window (TwinCAT 2)*

In TwinCAT 3 a similar window appears, which also offers the Web update:

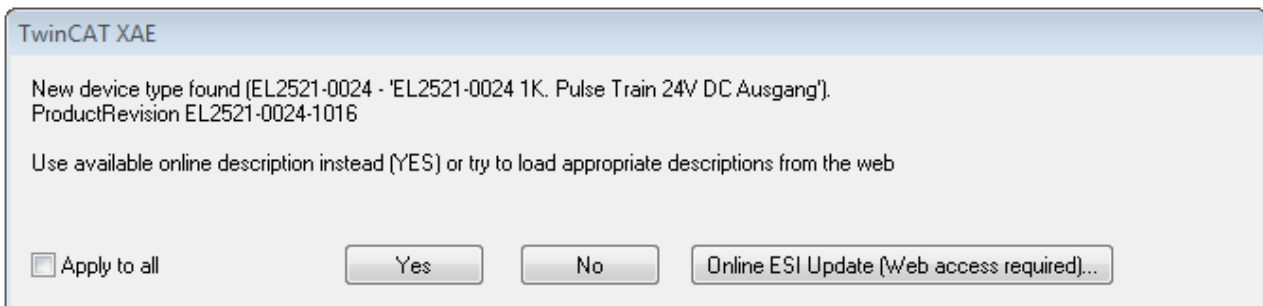



Fig. 42: *Information window OnlineDescription (TwinCAT 3)*

If possible, the Yes is to be rejected and the required ESI is to be requested from the device manufacturer. After installation of the XML/XSD file the configuration process should be repeated.

 Attention	<p>Changing the 'usual' configuration through a scan</p> <ul style="list-style-type: none"> ✓ If a scan discovers a device that is not yet known to TwinCAT, distinction has to be made between two cases. Taking the example here of the EL2521-0000 in the revision 1019 <ol style="list-style-type: none"> a) no ESI is present for the EL2521-0000 device at all, either for the revision 1019 or for an older revision. The ESI must then be requested from the manufacturer (in this case Beckhoff). b) an ESI is present for the EL2521-0000 device, but only in an older revision, e.g. 1018 or 1017. In this case an in-house check should first be performed to determine whether the spare parts stock allows the integration of the increased revision into the configuration at all. A new/higher revision usually also brings along new features. If these are not to be used, work can continue without reservations with the previous revision 1018 in the configuration. This is also stated by the Beckhoff compatibility rule.
---	---

Refer in particular to the chapter '[General notes on the use of Beckhoff EtherCAT IO components](#)' and for manual configuration to the chapter '[Offline configuration creation](#)' [► 54].

If the OnlineDescription is used regardless, the System Manager reads a copy of the device description from the EEPROM in the EtherCAT slave. In complex slaves the size of the EEPROM may not be sufficient for the complete ESI, in which case the ESI would be *incomplete* in the configurator. Therefore it's recommended using an offline ESI file with priority in such a case.

The System Manager creates for online recorded device descriptions a new file "OnlineDescription0000...xml" in its ESI directory, which contains all ESI descriptions that were read online.

OnlineDescriptionCache00000002.xml

Fig. 43: File OnlineDescription.xml created by the System Manager

If a slave desired to be added manually to the configuration at a later stage, online created slaves are indicated by a prepended symbol ">" in the selection list (see Figure "Indication of an online recorded ESI of EL2521 as an example").

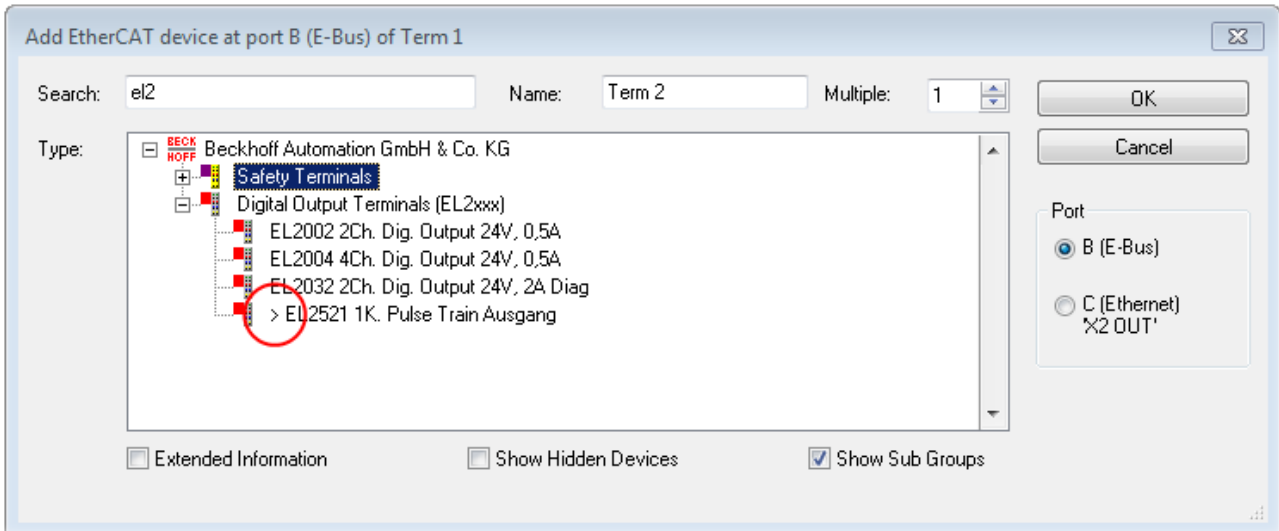



Fig. 44: Indication of an online recorded ESI of EL2521 as an example

If such ESI files are used and the manufacturer's files become available later, the file OnlineDescription.xml should be deleted as follows:

- close all System Manager windows
- restart TwinCAT in Config mode
- delete "OnlineDescription0000...xml"
- restart TwinCAT System Manager

This file should not be visible after this procedure, if necessary press <F5> to update

 Note	<p>OnlineDescription for TwinCAT 3.x</p> <p>In addition to the file described above "OnlineDescription0000...xml" , a so called EtherCAT cache with new discovered devices is created by TwinCAT 3.x, e.g. under Windows 7:</p> <p><code>C:\User\{USERNAME}\AppData\Roaming\Beckhoff\TwinCAT3\Components\Base\EtherCATCache.xml</code></p> <p>(Please note the language settings of the OS!)</p> <p>You have to delete this file, too.</p>
--	---

Faulty ESI file

If an ESI file is faulty and the System Manager is unable to read it, the System Manager brings up an information window.

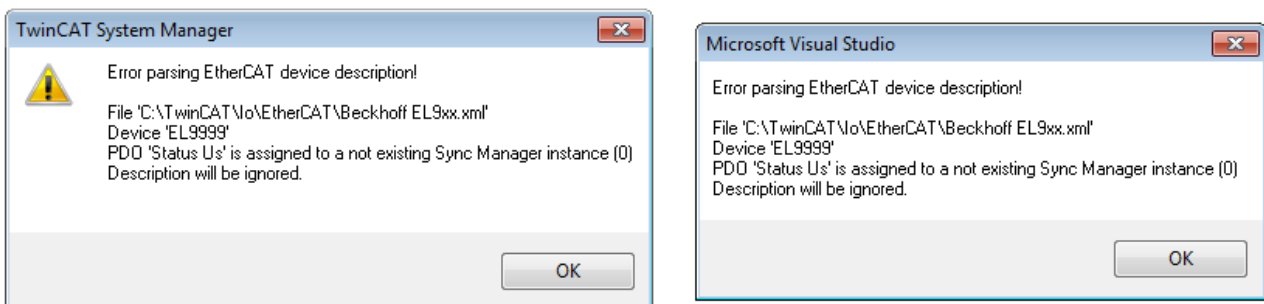

Fig. 45: Information window for faulty ESI file (left: TwinCAT 2; right: TwinCAT 3)

Reasons may include:

- Structure of the *.xml does not correspond to the associated *.xsd file → check your schematics
- Contents cannot be translated into a device description → contact the file manufacturer

6.2.3 TwinCAT ESI Updater

For TwinCAT 2.11 and higher, the System Manager can search for current Beckhoff ESI files automatically, if an online connection is available:

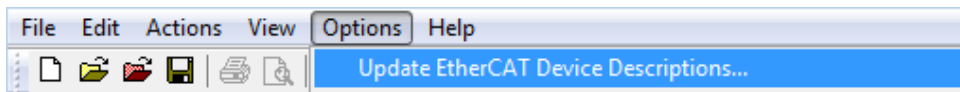

Fig. 46: Using the ESI Updater (>= TwinCAT 2.11)

The call up takes place under:
 “Options” → “Update EtherCAT Device Descriptions”

Selection under TwinCAT 3:

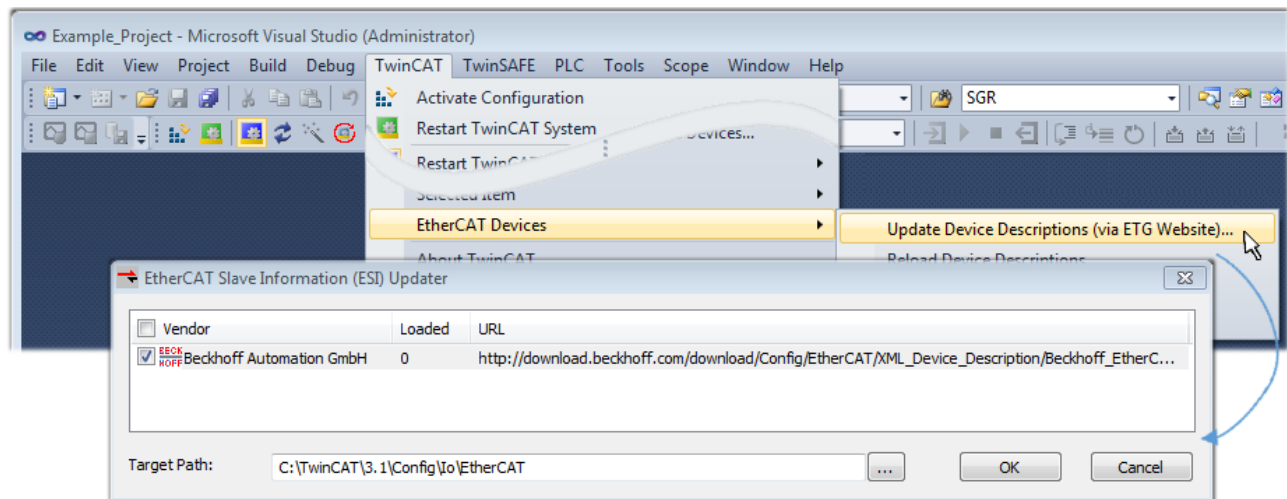

Fig. 47: Using the ESI Updater (TwinCAT 3)

The ESI Updater (TwinCAT 3) is a convenient option for automatic downloading of ESI data provided by EtherCAT manufacturers via the Internet into the TwinCAT directory (ESI = EtherCAT slave information). TwinCAT accesses the central ESI ULR directory list stored at ETG; the entries can then be viewed in the Updater dialog, although they cannot be changed there.

The call up takes place under:
 “TwinCAT” → „EtherCAT Devices“ → “Update Device Description (via ETG Website)...”.

6.2.4 Distinction between Online and Offline

The distinction between online and offline refers to the presence of the actual I/O environment (drives, terminals, EJ-modules). If the configuration is to be prepared in advance of the system configuration as a programming system, e.g. on a laptop, this is only possible in “Offline configuration” mode. In this case all components have to be entered manually in the configuration, e.g. based on the electrical design.

If the designed control system is already connected to the EtherCAT system and all components are energised and the infrastructure is ready for operation, the TwinCAT configuration can simply be generated through “scanning” from the runtime system. This is referred to as online configuration.

In any case, during each startup the EtherCAT master checks whether the slaves it finds match the configuration. This test can be parameterised in the extended slave settings. Refer to note “Installation of the latest ESI-XML device description” [▶ 49].

For preparation of a configuration:

- the real EtherCAT hardware (devices, couplers, drives) must be present and installed
- the devices/modules must be connected via EtherCAT cables or in the terminal/ module strand in the same way as they are intended to be used later

- the devices/modules be connected to the power supply and ready for communication
- TwinCAT must be in CONFIG mode on the target system.

The online scan process consists of:

- detecting the EtherCAT device [▶ 59] (Ethernet port at the IPC)
- detecting the connected EtherCAT devices [▶ 60]. This step can be carried out independent of the preceding step
- troubleshooting [▶ 63]

The scan with existing configuration [▶ 64] can also be carried out for comparison.

6.2.5 OFFLINE configuration creation

Creating the EtherCAT device

Create an EtherCAT device in an empty System Manager window.

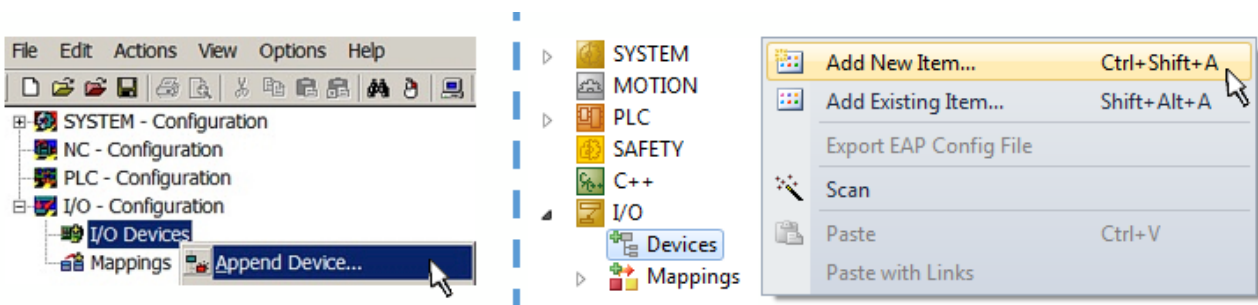

Fig. 48: Append EtherCAT device (left: TwinCAT 2; right: TwinCAT 3)

Select type 'EtherCAT' for an EtherCAT I/O application with EtherCAT slaves. For the present publisher/ subscriber service in combination with an EL6601/EL6614 terminal select "EtherCAT Automation Protocol via EL6601".

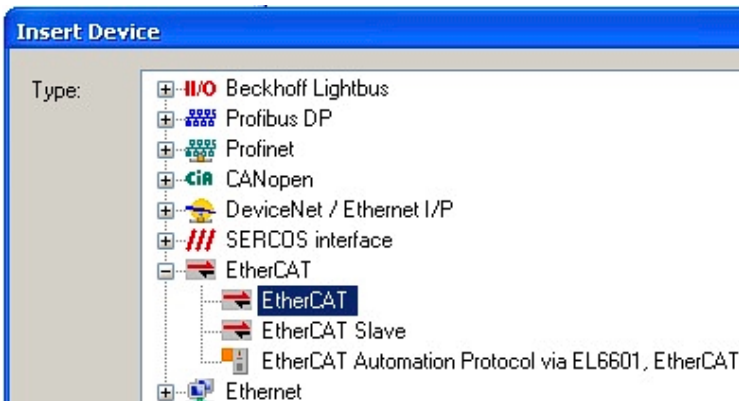

Fig. 49: Selecting the EtherCAT connection (TwinCAT 2.11, TwinCAT 3)

Then assign a real Ethernet port to this virtual device in the runtime system.

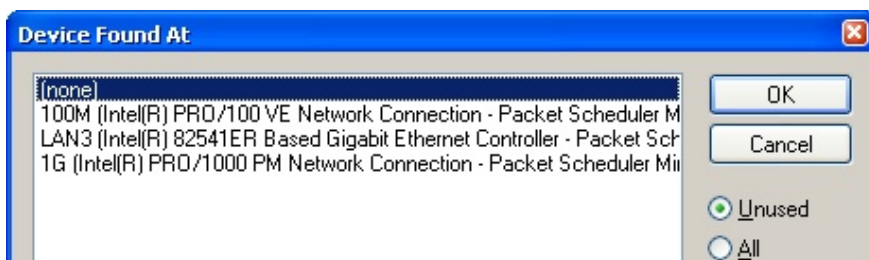

Fig. 50: Selecting the Ethernet port

This query may appear automatically when the EtherCAT device is created, or the assignment can be set/modified later in the properties dialog; see Fig. “EtherCAT device properties (TwinCAT 2)”.

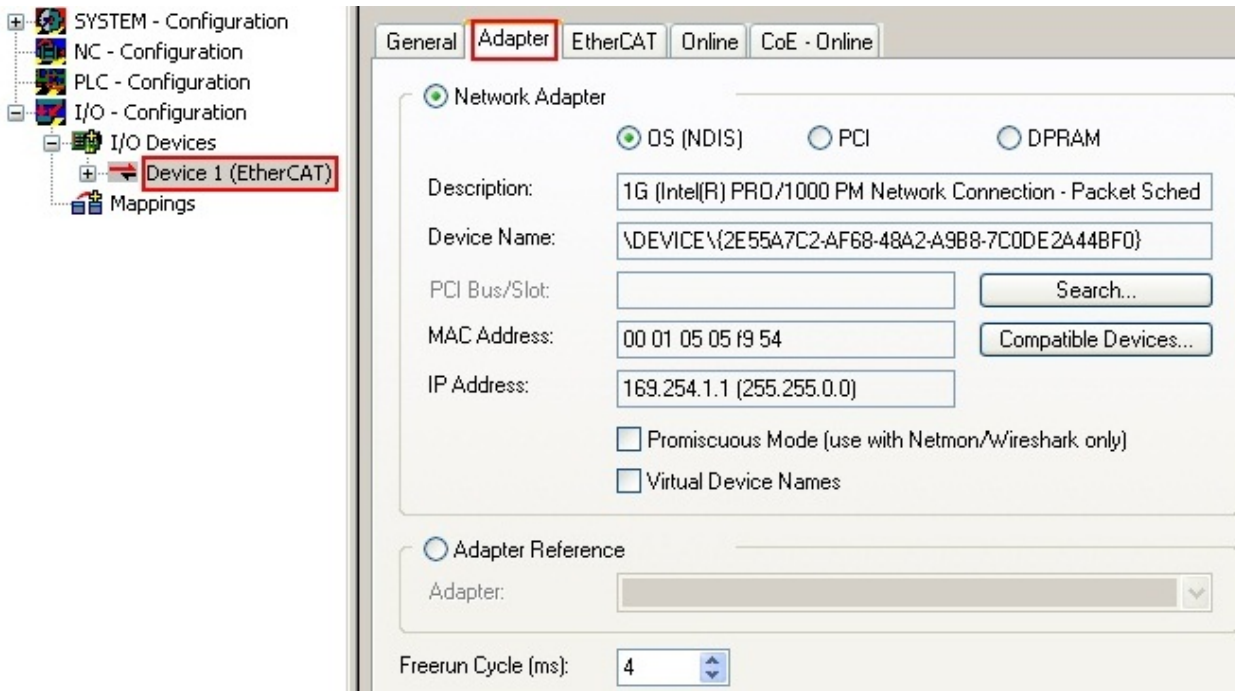
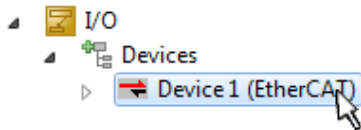



Fig. 51: EtherCAT device properties (TwinCAT 2)

TwinCAT 3: the properties of the EtherCAT device can be opened by double click on “Device .. (EtherCAT)” within the Solution Explorer under “I/O”:



 Note	<p>Selecting the Ethernet port</p> <p>Ethernet ports can only be selected for EtherCAT devices for which the TwinCAT real-time driver is installed. This has to be done separately for each port. Please refer to the respective installation page [▶ 44].</p>
--	---

Defining EtherCAT slaves

Further devices can be appended by right-clicking on a device in the configuration tree.

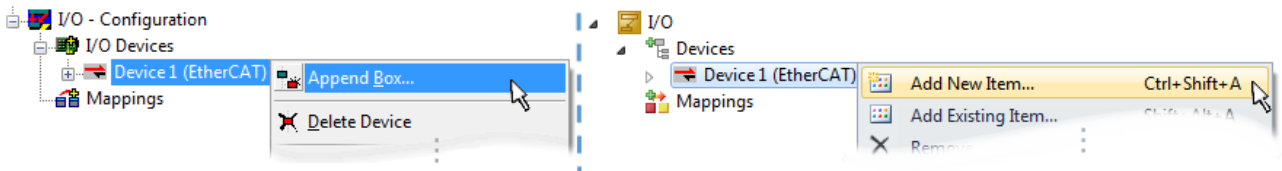

Fig. 52: Appending EtherCAT devices (left: TwinCAT 2; right: TwinCAT 3)

The dialog for selecting a new device opens. Only devices for which ESI files are available are displayed.

Only devices are offered for selection that can be appended to the previously selected device. Therefore the physical layer available for this port is also displayed (Fig. “Selection dialog for new EtherCAT device”, A). In the case of cable-based Fast-Ethernet physical layer with PHY transfer, then also only cable-based devices are available, as shown in Fig. “Selection dialog for new EtherCAT device”. If the preceding device has several free ports (e.g. EK1122 or EK1100), the required port can be selected on the right-hand side (A).

Overview of physical layer

- “Ethernet”: cable-based 100BASE-TX: EK couplers, EP boxes, devices with RJ45/M8/M12 connector

- “E-Bus”: LVDS “terminal bus”, “EJ-module”: EL/ES terminals, various modular modules

The search field facilitates finding specific devices (since TwinCAT 2.11 or TwinCAT 3).

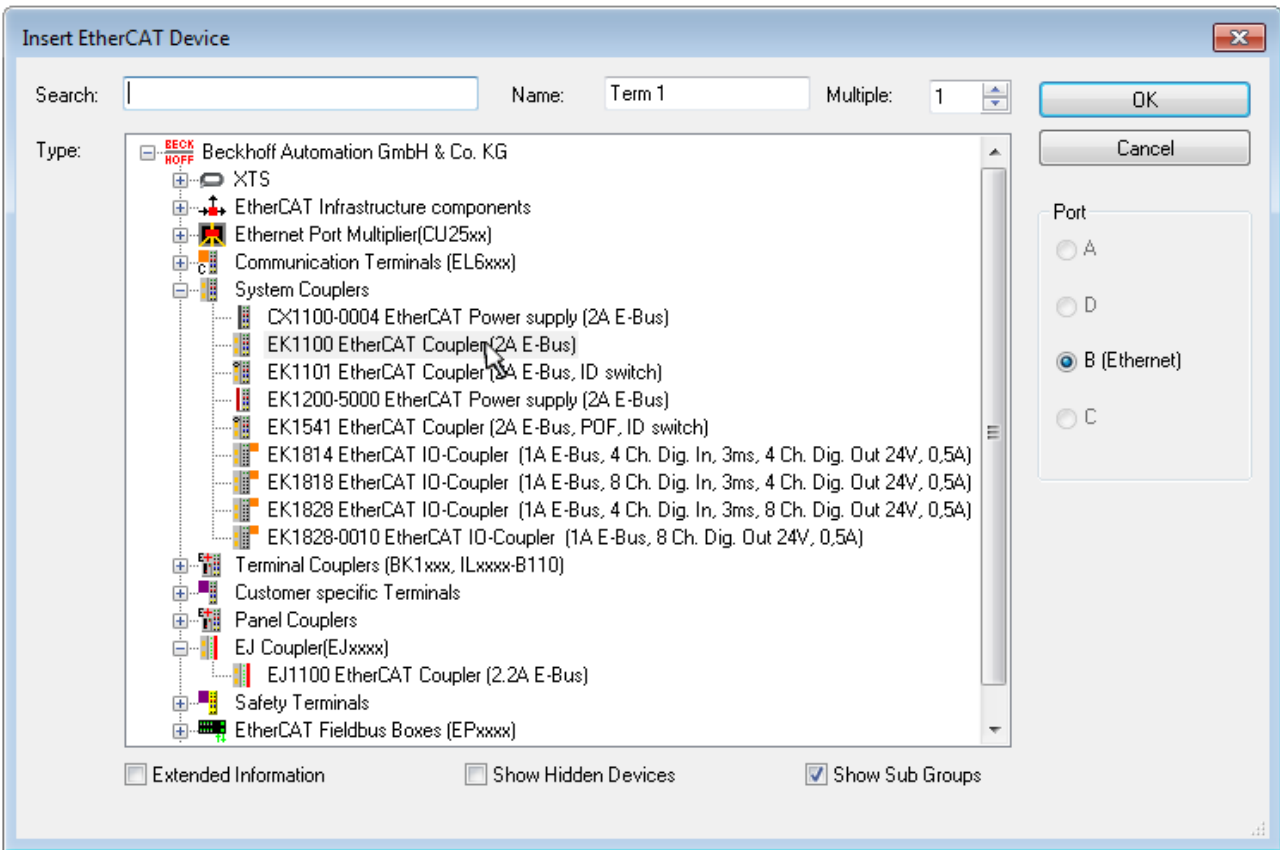

Fig. 53: Selection dialog for new EtherCAT device

By default only the name/device type is used as selection criterion. For selecting a specific revision of the device the revision can be displayed as “Extended Information”.

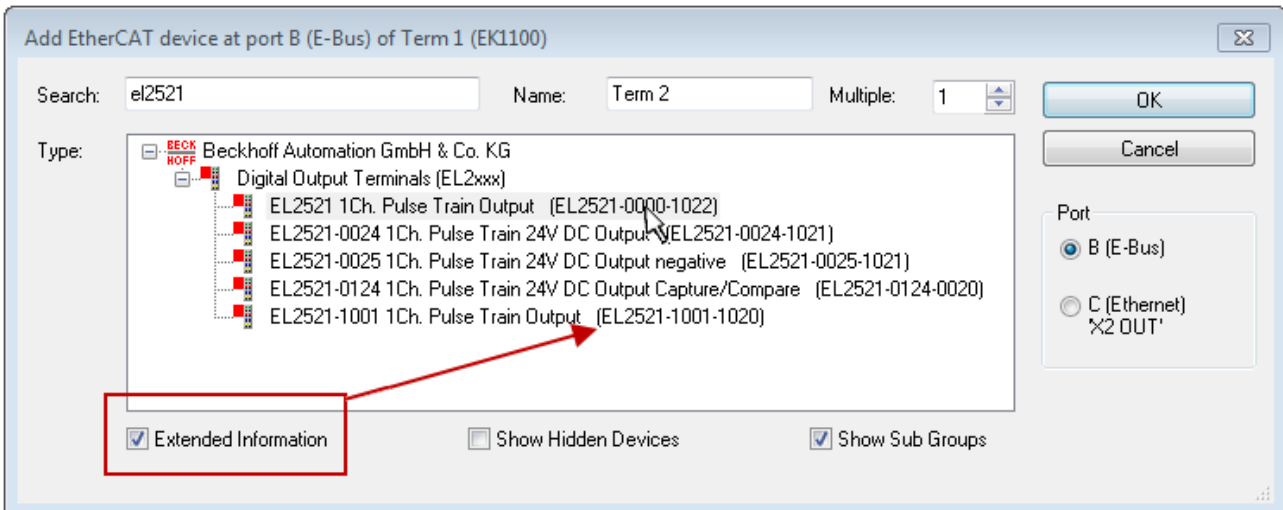

Fig. 54: Display of device revision

In many cases several device revisions were created for historic or functional reasons, e.g. through technological advancement. For simplification purposes (see Fig. “Selection dialog for new EtherCAT device”) only the last (i.e. highest) revision and therefore the latest state of production is displayed in the selection dialog for Beckhoff devices. To show all device revisions available in the system as ESI descriptions tick the “Show Hidden Devices” check box, see Fig. “Display of previous revisions”.

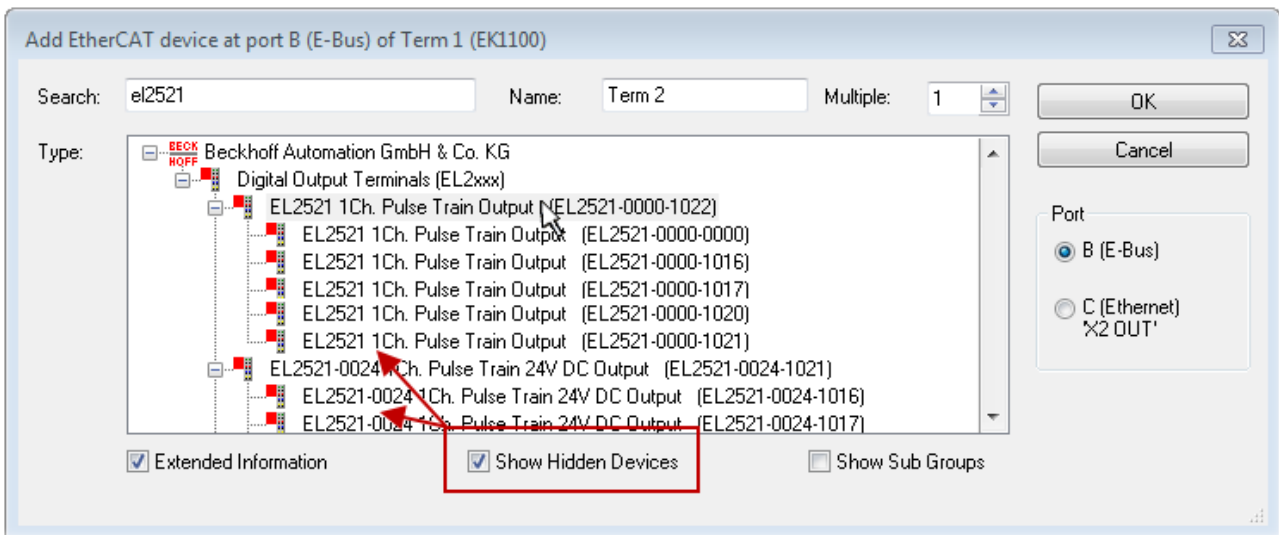



Fig. 55: Display of previous revisions

 Note	<p>Device selection based on revision, compatibility</p> <p>The ESI description also defines the process image, the communication type between master and slave/device and the device functions, if applicable. The physical device (firmware, if available) has to support the communication queries/settings of the master. This is backward compatible, i.e. newer devices (higher revision) should be supported if the EtherCAT master addresses them as an older revision. The following compatibility rule of thumb is to be assumed for Beckhoff EtherCAT Terminals/ Boxes/ EJ-modules:</p> <p>device revision in the system >= device revision in the configuration</p> <p>This also enables subsequent replacement of devices without changing the configuration (different specifications are possible for drives).</p>
--	--

Example:

If an EL2521-0025-**1018** is specified in the configuration, an EL2521-0025-**1018** or higher (**-1019**, **-1020**) can be used in practice.

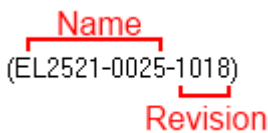

Fig. 56: Name/revision of the terminal

If current ESI descriptions are available in the TwinCAT system, the last revision offered in the selection dialog matches the Beckhoff state of production. It is recommended to use the last device revision when creating a new configuration, if current Beckhoff devices are used in the real application. Older revisions should only be used if older devices from stock are to be used in the application.

In this case the process image of the device is shown in the configuration tree and can be parameterised as follows: linking with the task, CoE/DC settings, plug-in definition, startup settings, ...

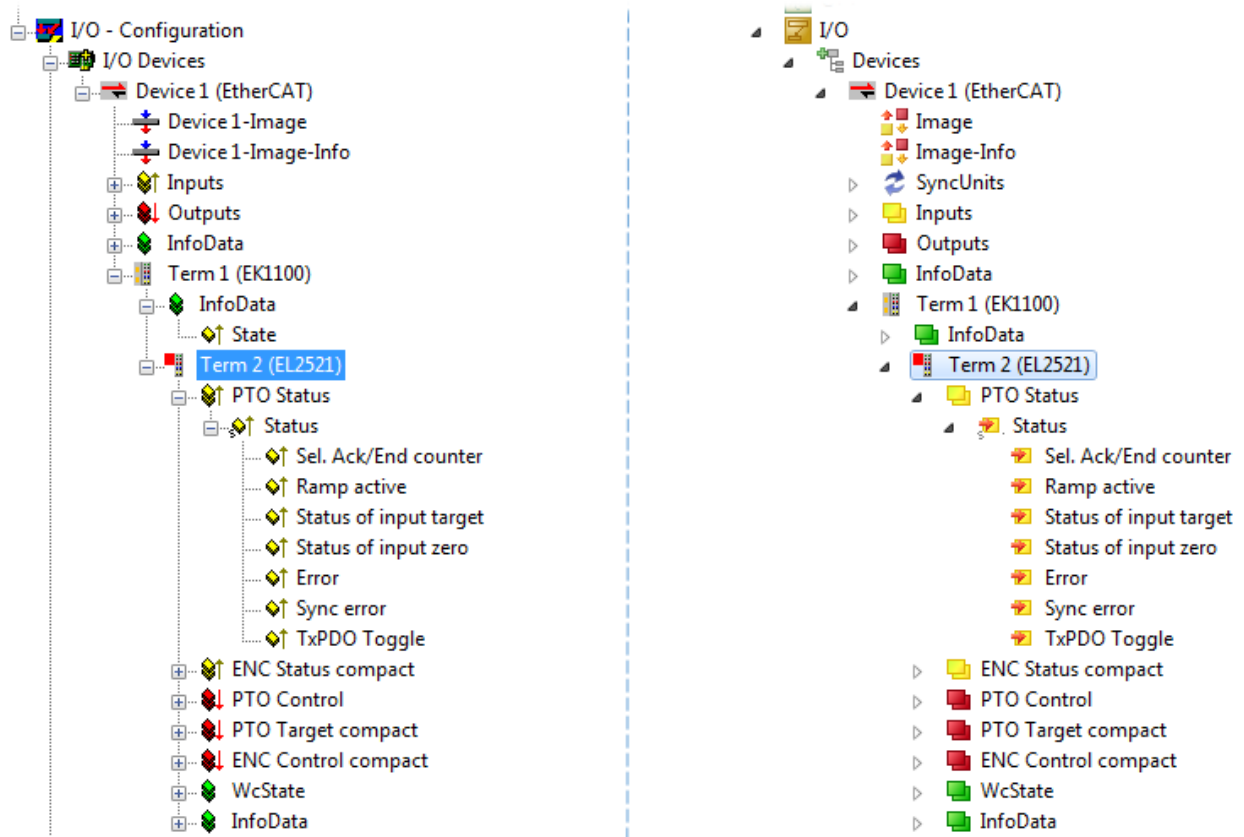



Fig. 57: EtherCAT terminal in the TwinCAT tree (left: TwinCAT 2; right: TwinCAT 3)



6.2.6 ONLINE configuration creation

Detecting/scanning of the EtherCAT device



The online device search can be used if the TwinCAT system is in CONFIG mode. This can be indicated by a symbol right below in the information bar:

- on TwinCAT 2 by a blue display “Config Mode” within the System Manager window:  .
- on TwinCAT 3 within the user interface of the development environment by a symbol  .

TwinCAT can be set into this mode:

- TwinCAT 2: by selection of  in the Menubar or by “Actions” → “Set/Reset TwinCAT to Config Mode...”
- TwinCAT 3: by selection of  in the Menubar or by „TwinCAT“ → “Restart TwinCAT (Config Mode)”

 Note	Online scanning in Config mode The online search is not available in RUN mode (production operation). Note the differentiation between TwinCAT programming system and TwinCAT target system.
--	--

The TwinCAT 2 icon () or TwinCAT 3 icon () within the Windows-Taskbar always shows the TwinCAT mode of the local IPC. Compared to that, the System Manager window of TwinCAT 2 or the user interface of TwinCAT 3 indicates the state of the target system.

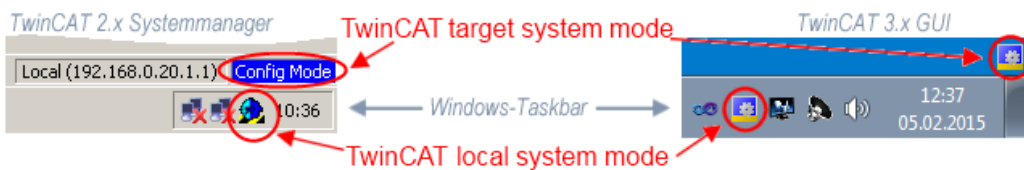

Fig. 58: Differentiation local/target system (left: TwinCAT 2; right: TwinCAT 3)

Right-clicking on “I/O Devices” in the configuration tree opens the search dialog.

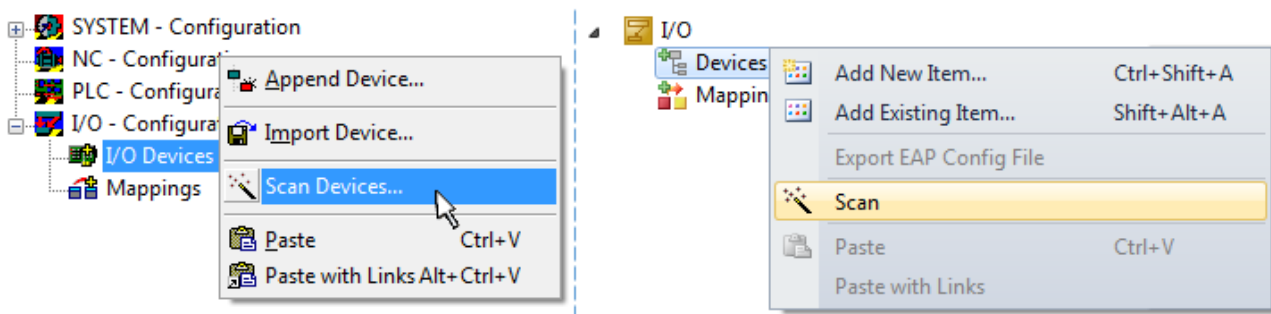

Fig. 59: Scan Devices (left: TwinCAT 2; right: TwinCAT 3)

This scan mode attempts to find not only EtherCAT devices (or Ethernet ports that are usable as such), but also NOVRAM, fieldbus cards, SMB etc. However, not all devices can be found automatically.

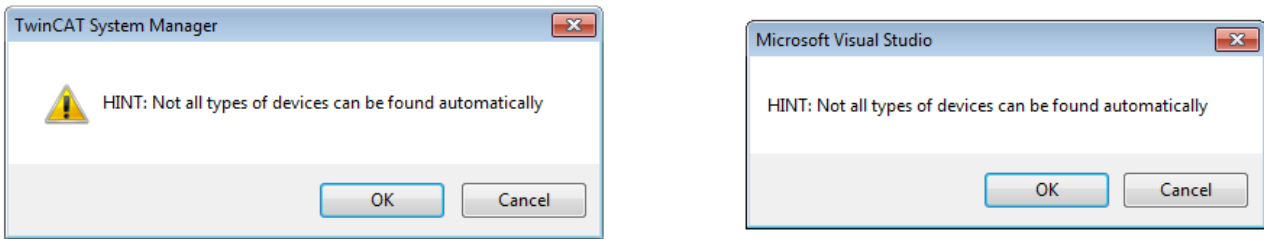

Fig. 60: Note for automatic device scan (left: TwinCAT 2; right: TwinCAT 3)

Ethernet ports with installed TwinCAT real-time driver are shown as “RT Ethernet” devices. An EtherCAT frame is sent to these ports for testing purposes. If the scan agent detects from the response that an EtherCAT slave is connected, the port is immediately shown as an “EtherCAT Device” .

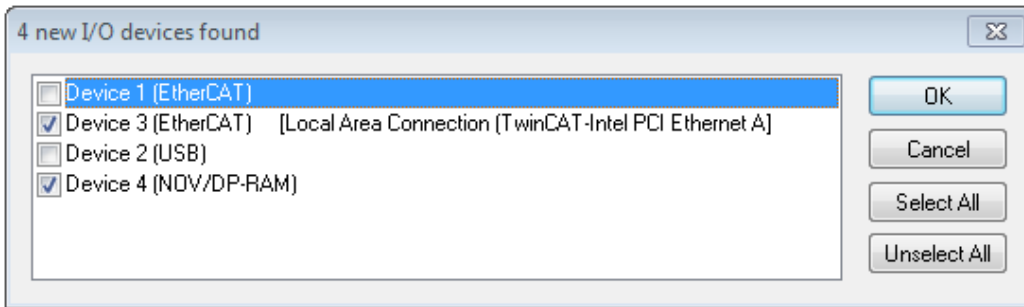



Fig. 61: Detected Ethernet devices

Via respective checkboxes devices can be selected (as illustrated in Fig. “Detected Ethernet devices” e.g. Device 3 and Device 4 were chosen). After confirmation with “OK” a device scan is suggested for all selected devices, see Fig.: “Scan query after automatic creation of an EtherCAT device”.

 Note	<p>Selecting the Ethernet port</p> <p>Ethernet ports can only be selected for EtherCAT devices for which the TwinCAT real-time driver is installed. This has to be done separately for each port. Please refer to the respective installation page ▶ 44 .</p>
--	---

Detecting/Scanning the EtherCAT devices

 Note	<p>Online scan functionality</p> <p>During a scan the master queries the identity information of the EtherCAT slaves from the slave EEPROM. The name and revision are used for determining the type. The respective devices are located in the stored ESI data and integrated in the configuration tree in the default state defined there.</p>
--	--

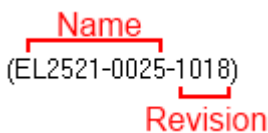



Fig. 62: Example default state

 Attention	<p>Slave scanning in practice in series machine production</p> <p>The scanning function should be used with care. It is a practical and fast tool for creating an initial configuration as a basis for commissioning. In series machine production or reproduction of the plant, however, the function should no longer be used for the creation of the configuration, but if necessary for comparison ▶ 64 with the defined initial configuration. Background: since Beckhoff occasionally increases the revision version of the delivered products for product maintenance reasons, a configuration can be created by such a scan which (with an identical machine construction) is identical according to the device list; however, the respective device revision may differ from the initial configuration.</p>
---	---

Example:

Company A builds the prototype of a machine B, which is to be produced in series later on. To do this the prototype is built, a scan of the IO devices is performed in TwinCAT and the initial configuration 'B.tsm' is created. The EL2521-0025 EtherCAT terminal with the revision 1018 is located somewhere. It is thus built into the TwinCAT configuration in this way:

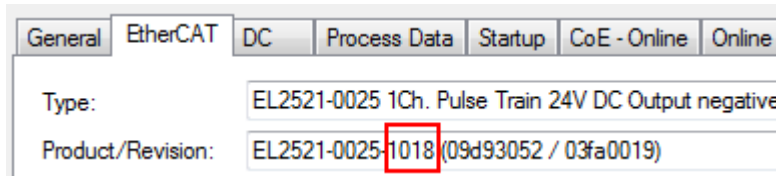

Fig. 63: Installing EtherCAT terminal with revision -1018

Likewise, during the prototype test phase, the functions and properties of this terminal are tested by the programmers/commissioning engineers and used if necessary, i.e. addressed from the PLC 'B.pro' or the NC. (the same applies correspondingly to the TwinCAT 3 solution files).

The prototype development is now completed and series production of machine B starts, for which Beckhoff continues to supply the EL2521-0025-0018. If the commissioning engineers of the series machine production department always carry out a scan, a B configuration with the identical contents results again for each machine. Likewise, A might create spare parts stores worldwide for the coming series-produced machines with EL2521-0025-1018 terminals.

After some time Beckhoff extends the EL2521-0025 by a new feature C. Therefore the FW is changed, outwardly recognizable by a higher FW version and a **new revision -1019**. Nevertheless the new device naturally supports functions and interfaces of the predecessor version(s); an adaptation of 'B.tsm' or even 'B.pro' is therefore unnecessary. The series-produced machines can continue to be built with 'B.tsm' and 'B.pro'; it makes sense to perform a comparative scan [▶ 64] against the initial configuration 'B.tsm' in order to check the built machine.

However, if the series machine production department now doesn't use 'B.tsm', but instead carries out a scan to create the productive configuration, the revision **-1019** is automatically detected and built into the configuration:

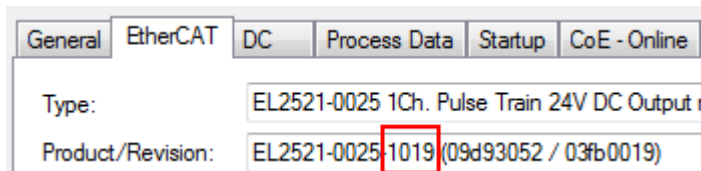

Fig. 64: Detection of EtherCAT terminal with revision -1019

This is usually not noticed by the commissioning engineers. TwinCAT cannot signal anything either, since virtually a new configuration is created. According to the compatibility rule, however, this means that no EL2521-0025-**1018** should be built into this machine as a spare part (even if this nevertheless works in the vast majority of cases).

In addition, it could be the case that, due to the development accompanying production in company A, the new feature C of the EL2521-0025-1019 (for example, an improved analog filter or an additional process data for the diagnosis) is discovered and used without in-house consultation. The previous stock of spare part devices are then no longer to be used for the new configuration 'B2.tsm' created in this way. If series machine production is established, the scan should only be performed for informative purposes for comparison with a defined initial configuration. Changes are to be made with care!

If an EtherCAT device was created in the configuration (manually or through a scan), the I/O field can be scanned for devices/slaves.

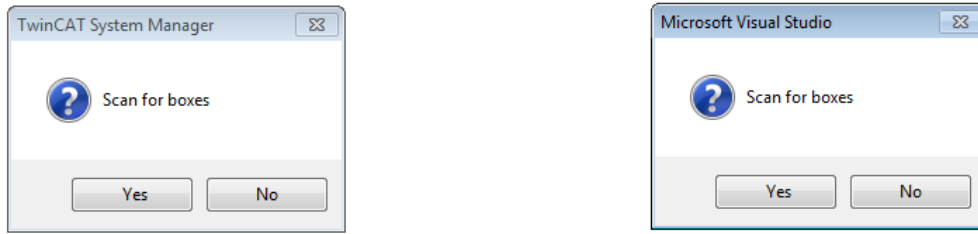

Fig. 65: Scan query after automatic creation of an EtherCAT device (left: TwinCAT 2; right: TwinCAT 3)

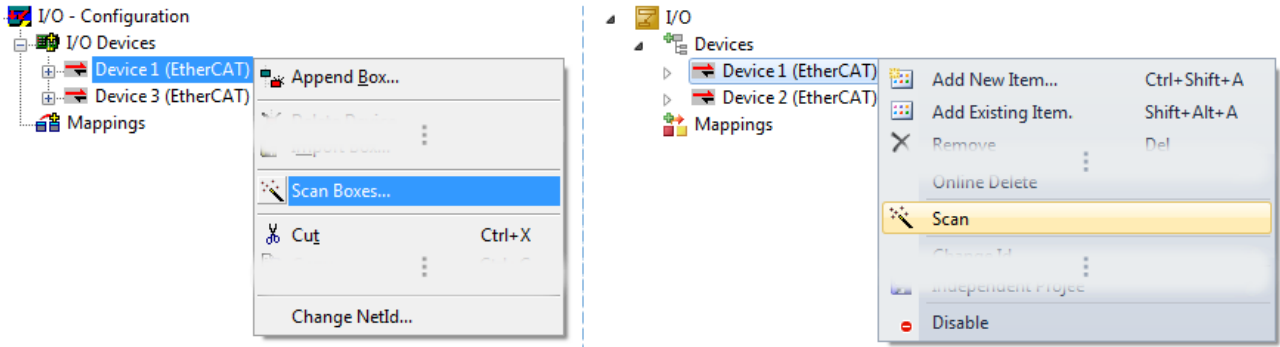

Fig. 66: Manual triggering of a device scan on a specified EtherCAT device (left: TwinCAT 2; right: TwinCAT 3)

In the System Manager (TwinCAT 2) or the User Interface (TwinCAT 3) the scan process can be monitored via the progress bar at the bottom in the status bar.

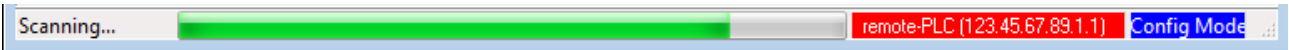

Fig. 67: Scan progress exemplary by TwinCAT 2

The configuration is established and can then be switched to online state (OPERATIONAL).



Fig. 68: Config/FreeRun query (left: TwinCAT 2; right: TwinCAT 3)

In Config/FreeRun mode the System Manager display alternates between blue and red, and the EtherCAT device continues to operate with the idling cycle time of 4 ms (default setting), even without active task (NC, PLC).



Fig. 69: Displaying of "Free Run" and "Config Mode" toggling right below in the status bar



Fig. 70: TwinCAT can also be switched to this state by using a button (left: TwinCAT 2; right: TwinCAT 3)

The EtherCAT system should then be in a functional cyclic state, as shown in Fig. "Online display example".

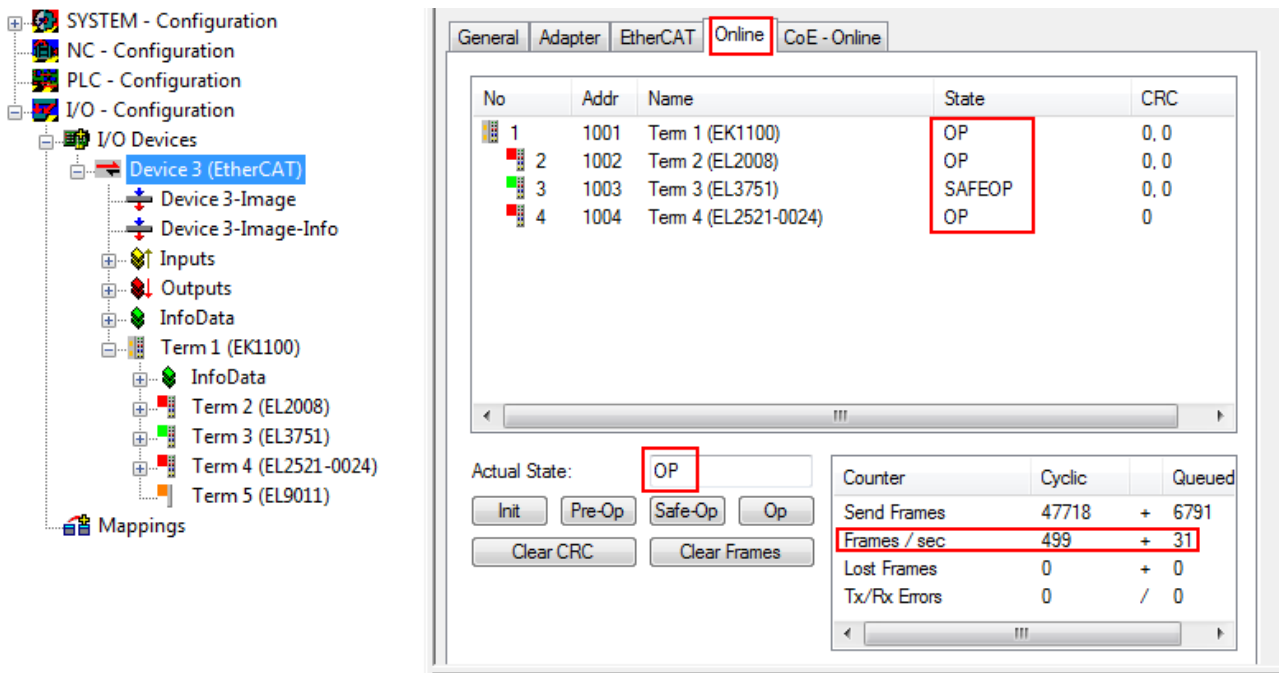

Fig. 71: Online display example

Please note:

- all slaves should be in OP state
- the EtherCAT master should be in “Actual State” OP
- “frames/sec” should match the cycle time taking into account the sent number of frames
- no excessive “LostFrames” or CRC errors should occur

The configuration is now complete. It can be modified as described under [manual procedure \[► 54\]](#).

Troubleshooting

Various effects may occur during scanning.

- An **unknown device** is detected, i.e. an EtherCAT slave for which no ESI XML description is available. In this case the System Manager offers to read any ESI that may be stored in the device. This case is described in the chapter "Notes regarding ESI device description".
- **Device are not detected properly**
Possible reasons include:
 - faulty data links, resulting in data loss during the scan
 - slave has invalid device description
 The connections and devices should be checked in a targeted manner, e.g. via the emergency scan. Then re-run the scan.

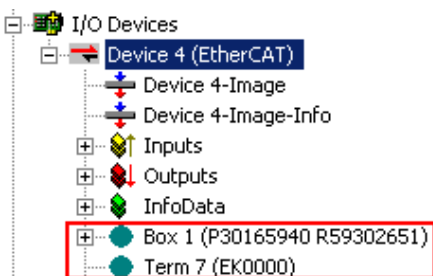



Fig. 72: Faulty identification

In the System Manager such devices may be set up as EK0000 or unknown devices. Operation is not possible or meaningful.

Scan over existing Configuration

 Attention	<p>Change of the configuration after comparison</p> <p>With this scan (TwinCAT 2.11 or 3.1) only the device properties vendor (manufacturer), device name and revision are compared at present! A 'ChangeTo' or 'Copy' should only be carried out with care, taking into consideration the Beckhoff IO compatibility rule (see above). The device configuration is then replaced by the revision found; this can affect the supported process data and functions.</p>
---	--

If a scan is initiated for an existing configuration, the actual I/O environment may match the configuration exactly or it may differ. This enables the configuration to be compared.



Fig. 73: Identical configuration (left: TwinCAT 2; right: TwinCAT 3)

If differences are detected, they are shown in the correction dialog, so that the user can modify the configuration as required.

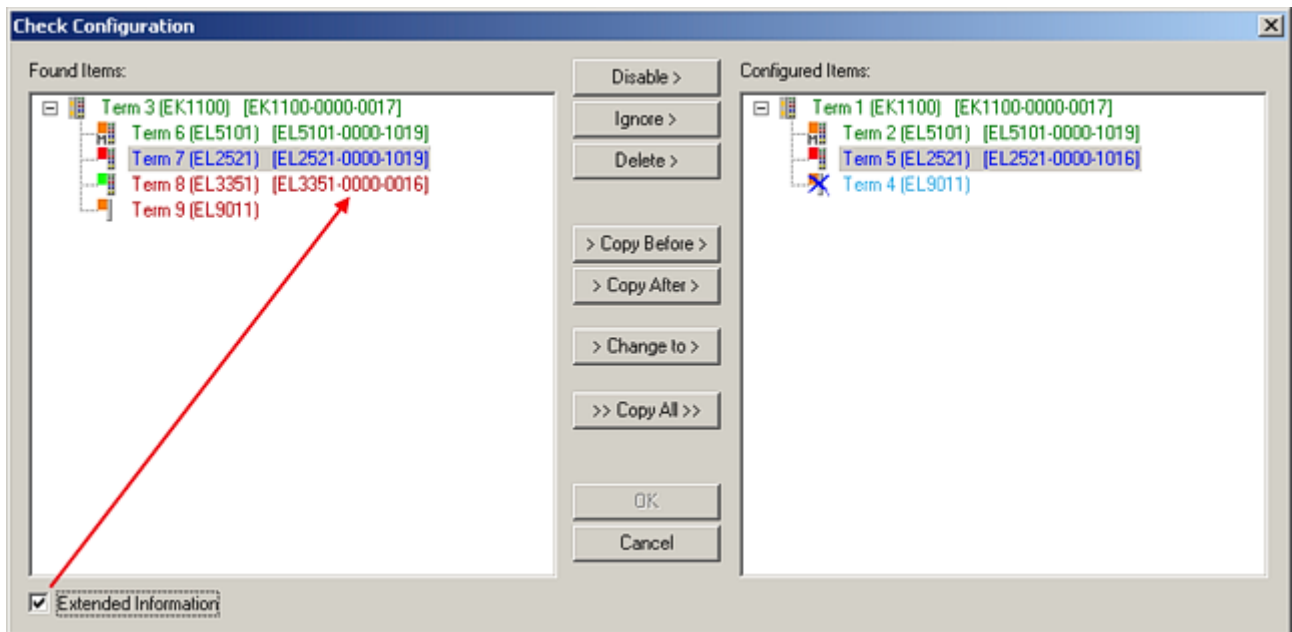

Fig. 74: Correction dialog

It is advisable to tick the "Extended Information" check box to reveal differences in the revision.

Colour	Explanation
green	This EtherCAT slave matches the entry on the other side. Both type and revision match.
blue	This EtherCAT slave is present on the other side, but in a different revision. This other revision can have other default values for the process data as well as other/additional functions. If the found revision is higher than the configured revision, the slave may be used provided compatibility issues are taken into account. If the found revision is lower than the configured revision, it is likely that the slave cannot be used. The found device may not support all functions that the master expects based on the higher revision number.
light blue	This EtherCAT slave is ignored ("Ignore" button)

Colour	Explanation
red	<ul style="list-style-type: none"> This EtherCAT slave is not present on the other side. It is present, but in a different revision, which also differs in its properties from the one specified. The compatibility principle then also applies here: if the found revision is higher than the configured revision, use is possible provided compatibility issues are taken into account, since the successor devices should support the functions of the predecessor devices. If the found revision is lower than the configured revision, it is likely that the slave cannot be used. The found device may not support all functions that the master expects based on the higher revision number.



Note

Device selection based on revision, compatibility

The ESI description also defines the process image, the communication type between master and slave/device and the device functions, if applicable. The physical device (firmware, if available) has to support the communication queries/settings of the master. This is backward compatible, i.e. newer devices (higher revision) should be supported if the EtherCAT master addresses them as an older revision. The following compatibility rule of thumb is to be assumed for Beckhoff EtherCAT Terminals/ Boxes/ EJ-modules:

device revision in the system >= device revision in the configuration

This also enables subsequent replacement of devices without changing the configuration (different specifications are possible for drives).

Example:

If an EL2521-0025-**1018** is specified in the configuration, an EL2521-0025-**1018** or higher (**-1019**, **-1020**) can be used in practice.

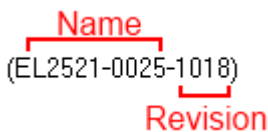

Fig. 75: Name/revision of the terminal

If current ESI descriptions are available in the TwinCAT system, the last revision offered in the selection dialog matches the Beckhoff state of production. It is recommended to use the last device revision when creating a new configuration, if current Beckhoff devices are used in the real application. Older revisions should only be used if older devices from stock are to be used in the application.

In this case the process image of the device is shown in the configuration tree and can be parameterised as follows: linking with the task, CoE/DC settings, plug-in definition, startup settings, ...

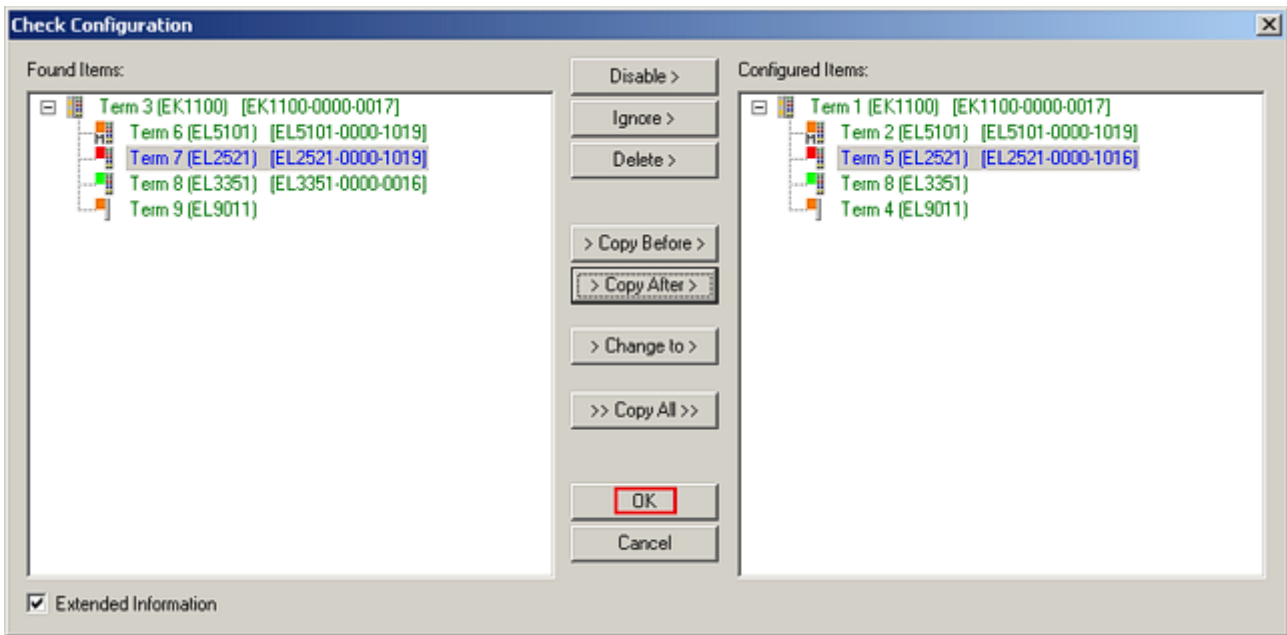

Fig. 76: Correction dialog with modifications

Once all modifications have been saved or accepted, click “OK” to transfer them to the real *.tsm configuration.

Change to Compatible Type

TwinCAT offers a function “Change to Compatible Type...” for the exchange of a device whilst retaining the links in the task.

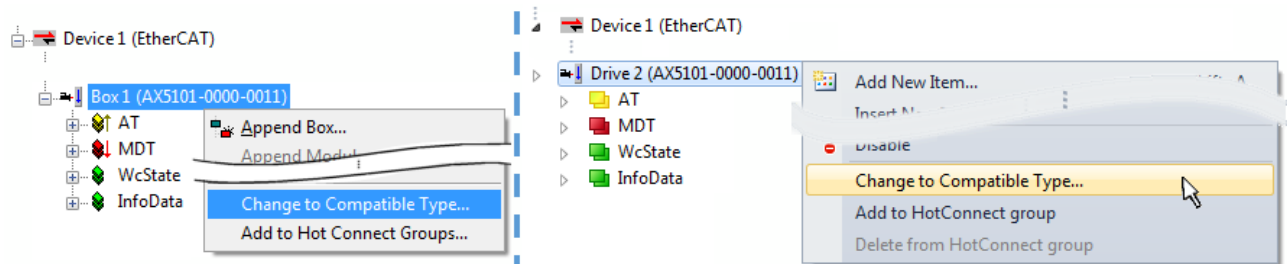

Fig. 77: Dialog “Change to Compatible Type...” (left: TwinCAT 2; right: TwinCAT 3)

This function is preferably to be used on AX5000 devices.

Change to Alternative Type

The TwinCAT System Manager offers a function for the exchange of a device: *Change to Alternative Type*

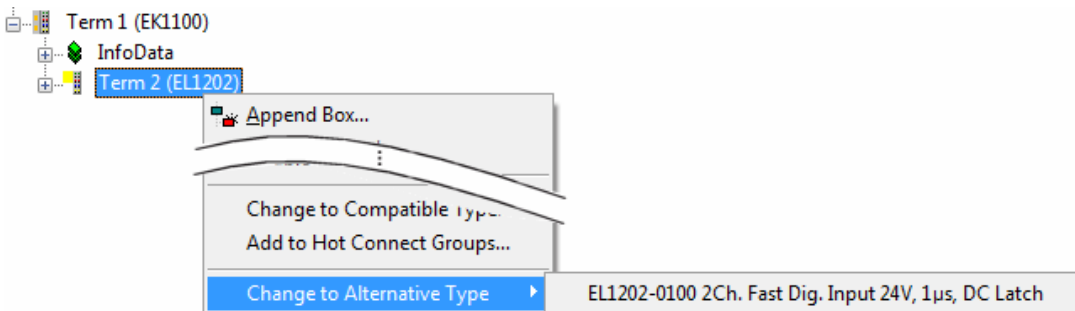

Fig. 78: TwinCAT 2 Dialog Change to Alternative Type

If called, the System Manager searches in the procured device ESI (in this example: EL1202-0000) for details of compatible devices contained there. The configuration is changed and the ESI-EEPROM is overwritten at the same time – therefore this process is possible only in the online state (ConfigMode).

6.2.7 EtherCAT subscriber configuration

In the left-hand window of the TwinCAT 2 System Manager or the Solution Explorer of the TwinCAT 3 Development Environment respectively, click on the element of the terminal within the tree you wish to configure (in the example: EL3751 Terminal 3).

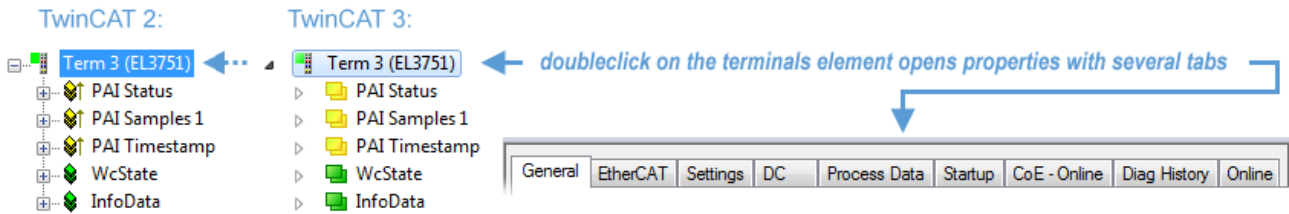

Fig. 79: Branch element as terminal EL3751

In the right-hand window of the TwinCAT System manager (TwinCAT 2) or the Development Environment (TwinCAT 3), various tabs are now available for configuring the terminal. And yet the dimension of complexity of a subscriber determines which tabs are provided. Thus as illustrated in the example above the terminal EL3751 provides many setup options and also a respective number of tabs are available. On the contrary by the terminal EL1004 for example the tabs "General", "EtherCAT", "Process Data" and "Online" are available only. Several terminals, as for instance the EL6695 provide special functions by a tab with its own terminal name, so "EL6695" in this case. A specific tab "Settings" by terminals with a wide range of setup options will be provided also (e.g. EL3751).

„General“ tab

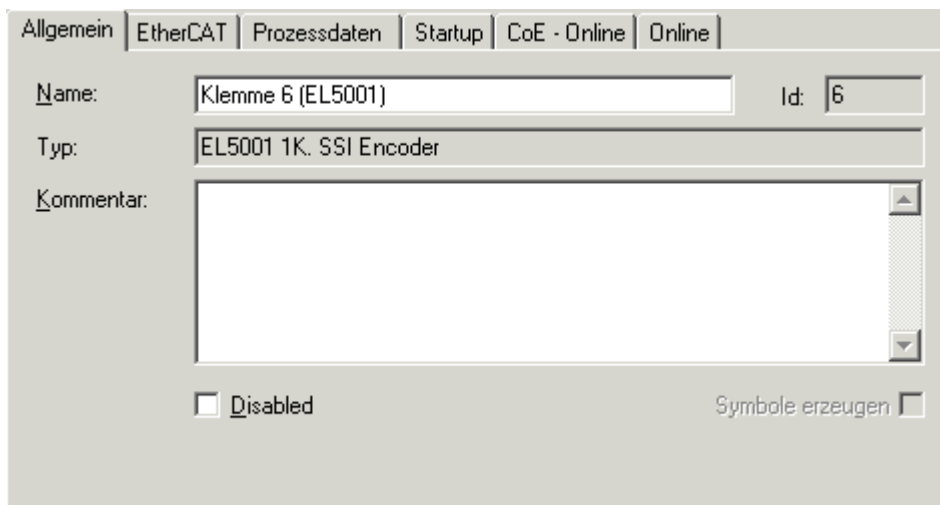

Fig. 80: "General" tab

Name	Name of the EtherCAT device
Id	Number of the EtherCAT device
Type	EtherCAT device type
Comment	Here you can add a comment (e.g. regarding the system).
Disabled	Here you can deactivate the EtherCAT device.
Create symbols	Access to this EtherCAT slave via ADS is only available if this control box is activated.

„EtherCAT“ tab

Fig. 81: „EtherCAT“ tab

Type	EtherCAT device type
Product/Revision	Product and revision number of the EtherCAT device
Auto Inc Addr.	Auto increment address of the EtherCAT device. The auto increment address can be used for addressing each EtherCAT device in the communication ring through its physical position. Auto increment addressing is used during the start-up phase when the EtherCAT master allocates addresses to the EtherCAT devices. With auto increment addressing the first EtherCAT slave in the ring has the address 0000 _{hex} . For each further slave the address is decremented by 1 (FFFF _{hex} , FFFE _{hex} etc.).
EtherCAT Addr.	Fixed address of an EtherCAT slave. This address is allocated by the EtherCAT master during the start-up phase. Tick the control box to the left of the input field in order to modify the default value.
Previous Port	Name and port of the EtherCAT device to which this device is connected. If it is possible to connect this device with another one without changing the order of the EtherCAT devices in the communication ring, then this combination field is activated and the EtherCAT device to which this device is to be connected can be selected.
Advanced Settings	This button opens the dialogs for advanced settings.

The link at the bottom of the tab points to the product page for this EtherCAT device on the web.

“Process Data” tab

Indicates the configuration of the process data. The input and output data of the EtherCAT slave are represented as CANopen process data objects (**P**rocess **D**ata **O**bjects, PDOs). The user can select a PDO via PDO assignment and modify the content of the individual PDO via this dialog, if the EtherCAT slave supports this function.

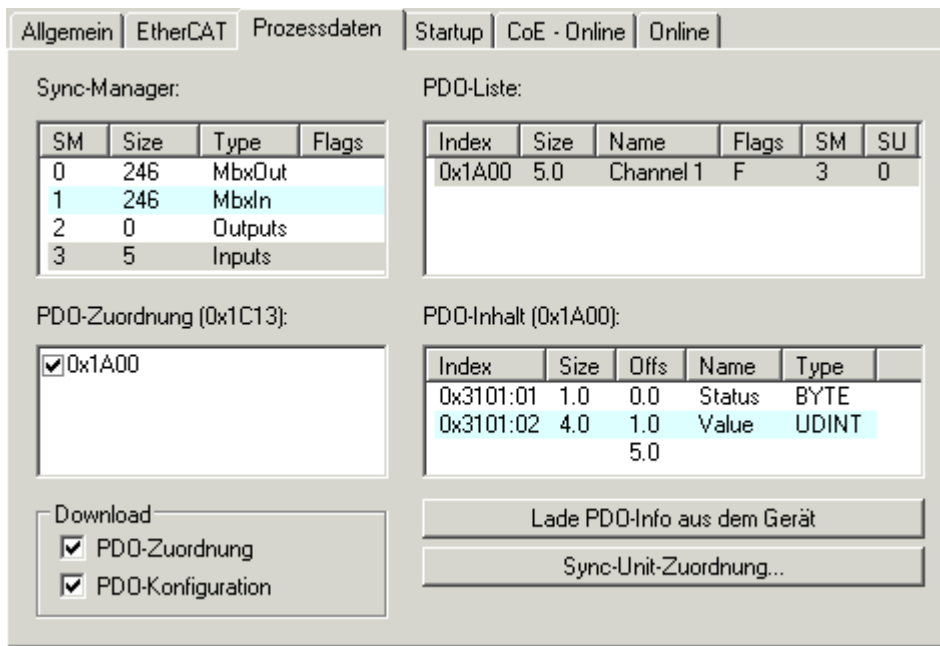

Fig. 82: "Process Data" tab

The process data (PDOs) transferred by an EtherCAT slave during each cycle are user data which the application expects to be updated cyclically or which are sent to the slave. To this end the EtherCAT master (Beckhoff TwinCAT) parameterizes each EtherCAT slave during the start-up phase to define which process data (size in bits/bytes, source location, transmission type) it wants to transfer to or from this slave. Incorrect configuration can prevent successful start-up of the slave.

For Beckhoff EtherCAT EL, ES, EM, EJ and EP slaves the following applies in general:

- The input/output process data supported by the device are defined by the manufacturer in the ESI/XML description. The TwinCAT EtherCAT Master uses the ESI description to configure the slave correctly.
- The process data can be modified in the system manager. See the device documentation. Examples of modifications include: mask out a channel, displaying additional cyclic information, 16-bit display instead of 8-bit data size, etc.
- In so-called "intelligent" EtherCAT devices the process data information is also stored in the CoE directory. Any changes in the CoE directory that lead to different PDO settings prevent successful startup of the slave. It is not advisable to deviate from the designated process data, because the device firmware (if available) is adapted to these PDO combinations.

If the device documentation allows modification of process data, proceed as follows (see Figure "Configuring the process data").

- A: select the device to configure
- B: in the "Process Data" tab select Input or Output under SyncManager (C)
- D: the PDOs can be selected or deselected
- H: the new process data are visible as linkable variables in the system manager
The new process data are active once the configuration has been activated and TwinCAT has been restarted (or the EtherCAT master has been restarted)
- E: if a slave supports this, Input and Output PDO can be modified simultaneously by selecting a so-called PDO record ("predefined PDO settings").

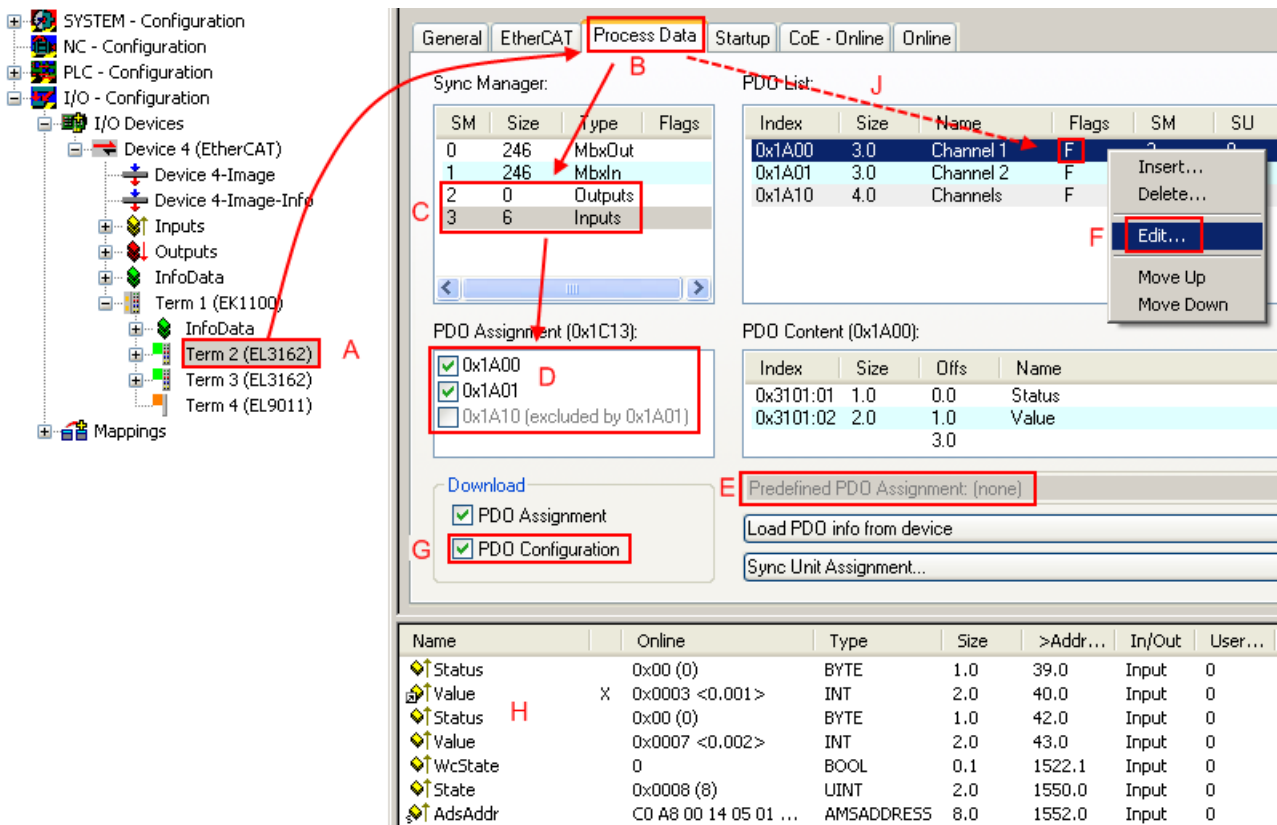

Fig. 83: Configuring the process data

i

Note

Manual modification of the process data

According to the ESI description, a PDO can be identified as “fixed” with the flag “F” in the PDO overview (Fig. “Configuring the process data”, J). The configuration of such PDOs cannot be changed, even if TwinCAT offers the associated dialog (“Edit”). In particular, CoE content cannot be displayed as cyclic process data. This generally also applies in cases where a device supports download of the PDO configuration, “G”. In case of incorrect configuration the EtherCAT slave usually refuses to start and change to OP state. The System Manager displays an “invalid SM cfg” logger message: This error message (“invalid SM IN cfg” or “invalid SM OUT cfg”) also indicates the reason for the failed start.

A detailed description [▶ 75] can be found at the end of this section.

„Startup“ tab

The *Startup* tab is displayed if the EtherCAT slave has a mailbox and supports the *CANopen over EtherCAT* (CoE) or *Servo drive over EtherCAT* protocol. This tab indicates which download requests are sent to the mailbox during startup. It is also possible to add new mailbox requests to the list display. The download requests are sent to the slave in the same order as they are shown in the list.

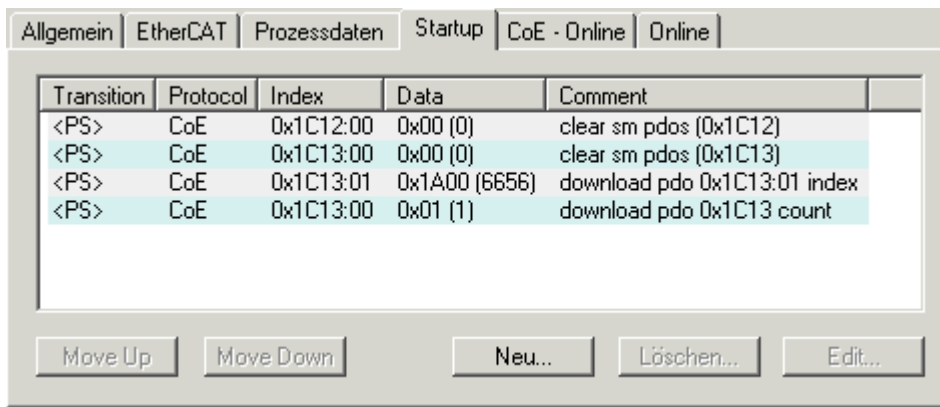

Fig. 84: „Startup“ tab

Column	Description
Transition	Transition to which the request is sent. This can either be <ul style="list-style-type: none"> the transition from pre-operational to safe-operational (PS), or the transition from safe-operational to operational (SO). If the transition is enclosed in "<>" (e.g. <PS>), the mailbox request is fixed and cannot be modified or deleted by the user.
Protocol	Type of mailbox protocol
Index	Index of the object
Data	Date on which this object is to be downloaded.
Comment	Description of the request to be sent to the mailbox

- Move Up** This button moves the selected request up by one position in the list.
- Move Down** This button moves the selected request down by one position in the list.
- New** This button adds a new mailbox download request to be sent during startup.
- Delete** This button deletes the selected entry.
- Edit** This button edits an existing request.

“CoE – Online” tab

The additional *CoE - Online* tab is displayed if the EtherCAT slave supports the *CANopen over EtherCAT* (CoE) protocol. This dialog lists the content of the object list of the slave (SDO upload) and enables the user to modify the content of an object from this list. Details for the objects of the individual EtherCAT devices can be found in the device-specific object descriptions.

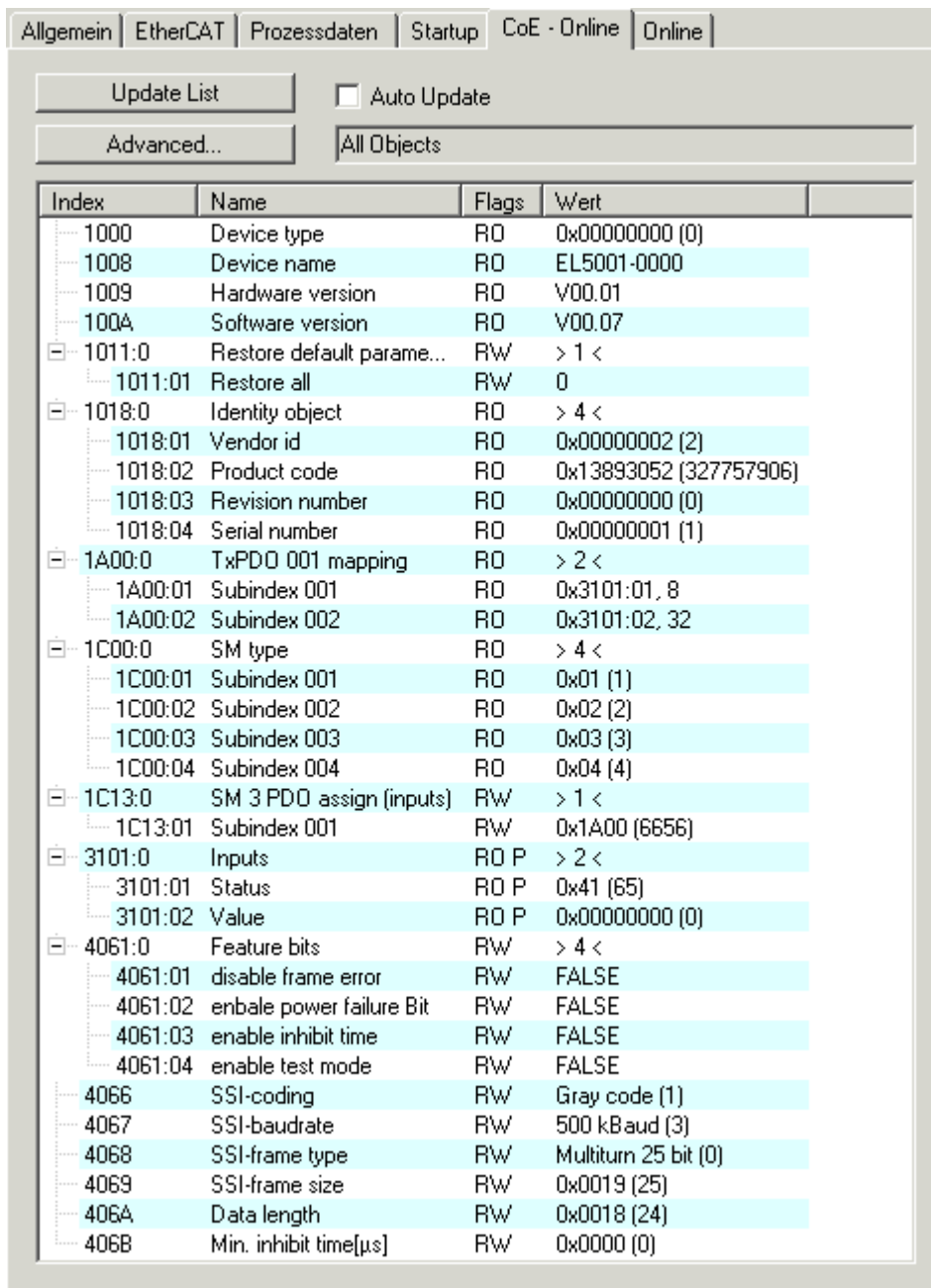

Fig. 85: "CoE – Online" tab

Object list display

Column	Description	
Index	Index and sub-index of the object	
Name	Name of the object	
Flags	RW	The object can be read, and data can be written to the object (read/write)
	RO	The object can be read, but no data can be written to the object (read only)
	P	An additional P identifies the object as a process data object.
Value	Value of the object	

Update List

The *Update list* button updates all objects in the displayed list

Auto Update

If this check box is selected, the content of the objects is updated automatically.

Advanced

The *Advanced* button opens the *Advanced Settings* dialog. Here you can specify which objects are displayed in the list.

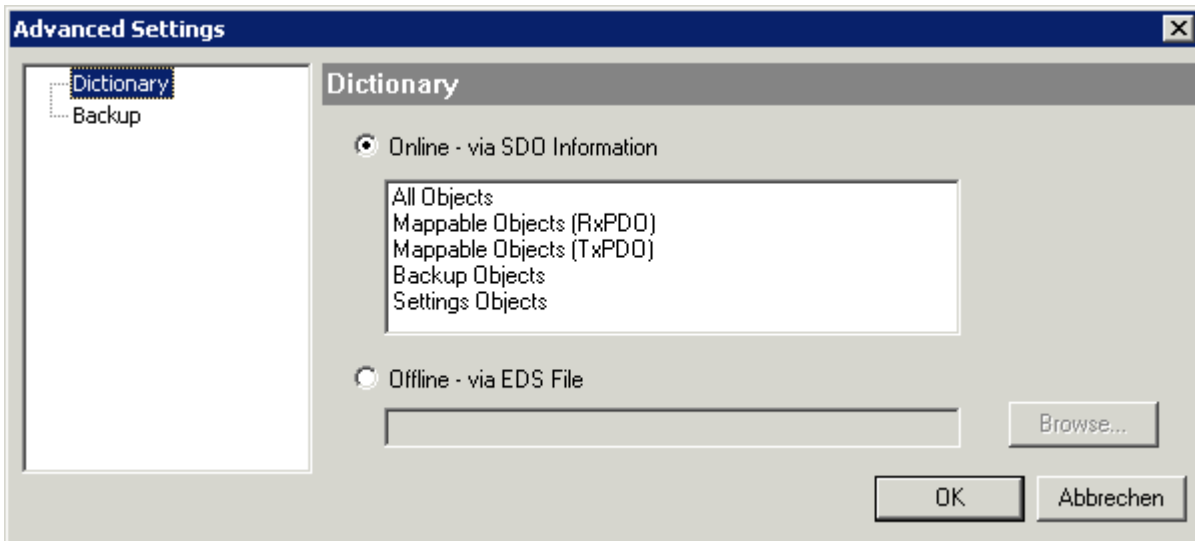

Fig. 86: Dialog “Advanced settings”

Online - via SDO Information	If this option button is selected, the list of the objects included in the object list of the slave is uploaded from the slave via SDO information. The list below can be used to specify which object types are to be uploaded.
Offline - via EDS File	If this option button is selected, the list of the objects included in the object list is read from an EDS file provided by the user.

„Online“ tab

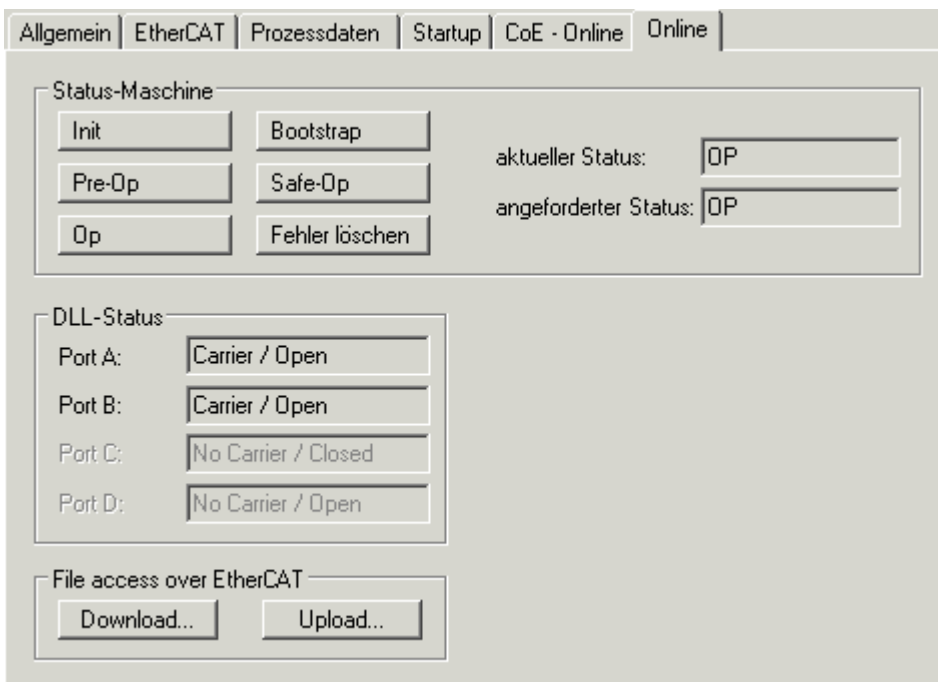

Fig. 87: „Online“ tab

State Machine

Init	This button attempts to set the EtherCAT device to the <i>Init</i> state.
Pre-Op	This button attempts to set the EtherCAT device to the <i>pre-operational</i> state.
Op	This button attempts to set the EtherCAT device to the <i>operational</i> state.
Bootstrap	This button attempts to set the EtherCAT device to the <i>Bootstrap</i> state.
Safe-Op	This button attempts to set the EtherCAT device to the <i>safe-operational</i> state.
Clear Error	This button attempts to delete the fault display. If an EtherCAT slave fails during change of state it sets an error flag. Example: An EtherCAT slave is in PREOP state (pre-operational). The master now requests the SAFEOP state (safe-operational). If the slave fails during change of state it sets the error flag. The current state is now displayed as ERR PREOP. When the <i>Clear Error</i> button is pressed the error flag is cleared, and the current state is displayed as PREOP again.
Current State	Indicates the current state of the EtherCAT device.
Requested State	Indicates the state requested for the EtherCAT device.

DLL Status

Indicates the DLL status (data link layer status) of the individual ports of the EtherCAT slave. The DLL status can have four different states:

Status	Description
No Carrier / Open	No carrier signal is available at the port, but the port is open.
No Carrier / Closed	No carrier signal is available at the port, and the port is closed.
Carrier / Open	A carrier signal is available at the port, and the port is open.
Carrier / Closed	A carrier signal is available at the port, but the port is closed.

File Access over EtherCAT

Download	With this button a file can be written to the EtherCAT device.
Upload	With this button a file can be read from the EtherCAT device.

"DC" tab (Distributed Clocks)

Fig. 88: "DC" tab (Distributed Clocks)

Operation Mode	Options (optional): <ul style="list-style-type: none"> • FreeRun • SM-Synchron • DC-Synchron (Input based) • DC-Synchron
Advanced Settings...	Advanced settings for readjustment of the real time determinant TwinCAT-clock

Detailed information to Distributed Clocks are specified on <http://infosys.beckhoff.com>:

Fieldbus Components → EtherCAT Terminals → EtherCAT System documentation → EtherCAT basics → Distributed Clocks

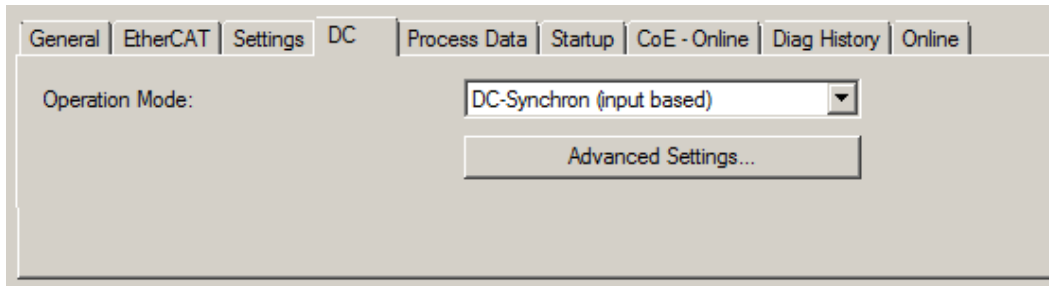
6.2.7.1 Detailed description of Process Data tab**Sync Manager**

Lists the configuration of the Sync Manager (SM).

If the EtherCAT device has a mailbox, SM0 is used for the mailbox output (MbxOut) and SM1 for the mailbox input (MbxIn).

SM2 is used for the output process data (outputs) and SM3 (inputs) for the input process data.

If an input is selected, the corresponding PDO assignment is displayed in the *PDO Assignment* list below.



PDO Assignment

PDO assignment of the selected Sync Manager. All PDOs defined for this Sync Manager type are listed here:

- If the output Sync Manager (outputs) is selected in the Sync Manager list, all RxPDOs are displayed.
- If the input Sync Manager (inputs) is selected in the Sync Manager list, all TxPDOs are displayed.

The selected entries are the PDOs involved in the process data transfer. In the tree diagram of the System Manager these PDOs are displayed as variables of the EtherCAT device. The name of the variable is identical to the *Name* parameter of the PDO, as displayed in the PDO list. If an entry in the PDO assignment list is deactivated (not selected and greyed out), this indicates that the input is excluded from the PDO assignment. In order to be able to select a greyed out PDO, the currently selected PDO has to be deselected first.

**Note****Activation of PDO assignment**

- ✓ If you have changed the PDO assignment, in order to activate the new PDO assignment,
 - a) the EtherCAT slave has to run through the PS status transition cycle (from pre-operational to safe-operational) once (see [Online tab \[► 73\]](#)),
 - b) and the System Manager has to reload the EtherCAT slaves
- ( button for TwinCAT 2 or  button for TwinCAT 3)

PDO list

List of all PDOs supported by this EtherCAT device. The content of the selected PDOs is displayed in the *PDO Content* list. The PDO configuration can be modified by double-clicking on an entry.

Column	Description	
Index	PDO index.	
Size	Size of the PDO in bytes.	
Name	Name of the PDO. If this PDO is assigned to a Sync Manager, it appears as a variable of the slave with this parameter as the name.	
Flags	F	Fixed content: The content of this PDO is fixed and cannot be changed by the System Manager.
	M	Mandatory PDO. This PDO is mandatory and must therefore be assigned to a Sync Manager! Consequently, this PDO cannot be deleted from the <i>PDO Assignment</i> list
SM	Sync Manager to which this PDO is assigned. If this entry is empty, this PDO does not take part in the process data traffic.	
SU	Sync unit to which this PDO is assigned.	

PDO Content

Indicates the content of the PDO. If flag F (fixed content) of the PDO is not set the content can be modified.

Download

If the device is intelligent and has a mailbox, the configuration of the PDO and the PDO assignments can be downloaded to the device. This is an optional feature that is not supported by all EtherCAT slaves.

PDO Assignment

If this check box is selected, the PDO assignment that is configured in the PDO Assignment list is downloaded to the device on startup. The required commands to be sent to the device can be viewed in the [Startup \[► 70\]](#) tab.

PDO Configuration

If this check box is selected, the configuration of the respective PDOs (as shown in the PDO list and the PDO Content display) is downloaded to the EtherCAT slave.

6.3 General Notes - EtherCAT Slave Application

This summary briefly deals with a number of aspects of EtherCAT Slave operation under TwinCAT. More detailed information on this may be found in the corresponding sections of, for instance, the [EtherCAT System Documentation](#).

Diagnosis in real time: WorkingCounter, EtherCAT State and Status

Generally speaking an EtherCAT Slave provides a variety of diagnostic information that can be used by the controlling task.

This diagnostic information relates to differing levels of communication. It therefore has a variety of sources, and is also updated at various times.

Any application that relies on I/O data from a fieldbus being correct and up to date must make diagnostic access to the corresponding underlying layers. EtherCAT and the TwinCAT System Manager offer comprehensive diagnostic elements of this kind. Those diagnostic elements that are helpful to the controlling task for diagnosis that is accurate for the current cycle when in operation (not during commissioning) are discussed below.

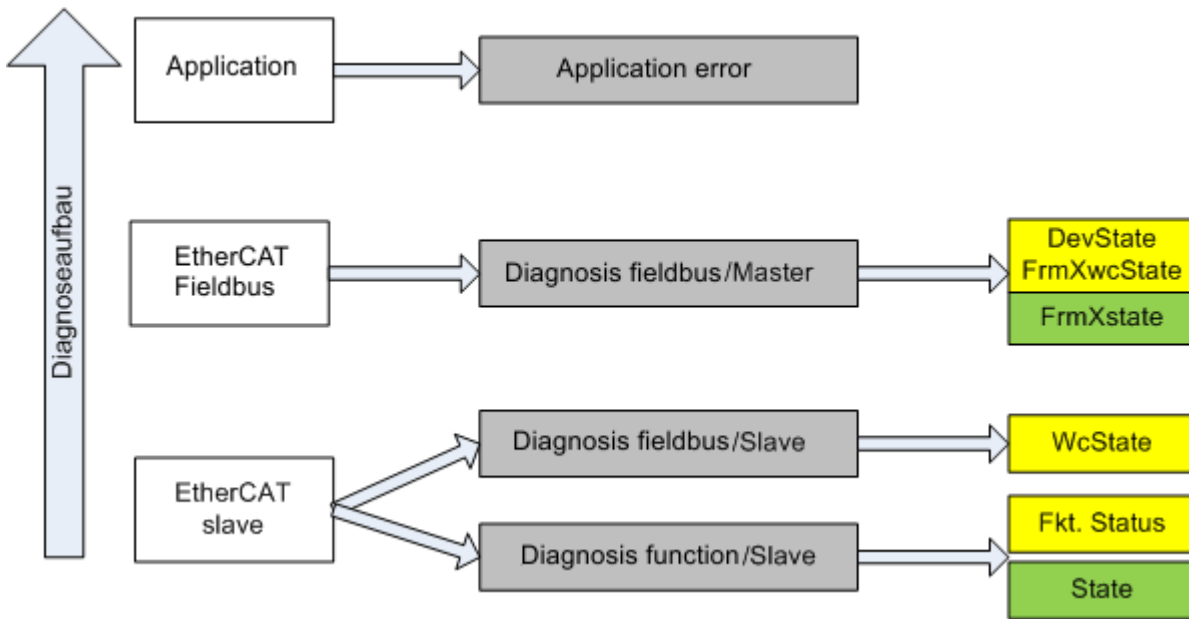

Fig. 89: Selection of the diagnostic information of an EtherCAT Slave

In general, an EtherCAT Slave offers

- communication diagnosis typical for a slave (diagnosis of successful participation in the exchange of process data, and correct operating mode)
This diagnosis is the same for all slaves.
- as well as
- function diagnosis typical for a channel (device-dependent)
See the corresponding device documentation

The colors in Fig. “Selection of the diagnostic information of an EtherCAT Slave” also correspond to the variable colors in the System Manager, see Fig. “Basic EtherCAT Slave Diagnosis in the PLC”.

Colour	Meaning
yellow	Input variables from the Slave to the EtherCAT Master, updated in every cycle
red	Output variables from the Slave to the EtherCAT Master, updated in every cycle
green	Information variables for the EtherCAT Master that are updated acyclically. This means that it is possible that in any particular cycle they do not represent the latest possible status. It is therefore useful to read such variables through ADS.

Fig. “Basic EtherCAT Slave Diagnosis in the PLC” shows an example of an implementation of basic EtherCAT Slave Diagnosis. A Beckhoff EL3102 (2-channel analogue input terminal) is used here, as it offers both the communication diagnosis typical of a slave and the functional diagnosis that is specific to a channel. Structures are created as input variables in the PLC, each corresponding to the process image.

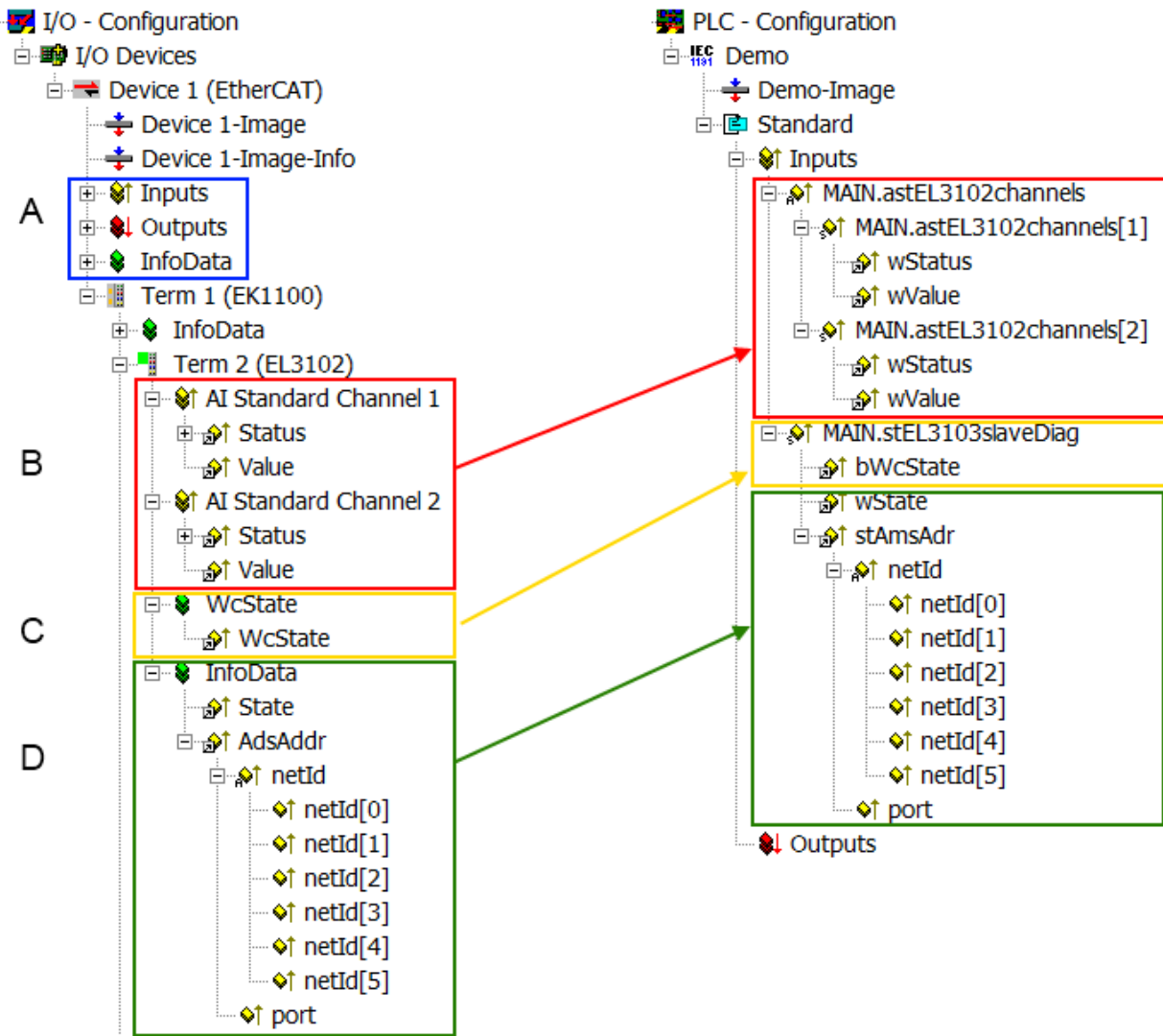

Fig. 90: Basic EtherCAT Slave Diagnosis in the PLC

The following aspects are covered here:

Code	Function	Implementation	Application/evaluation
A	The EtherCAT Master's diagnostic information updated acyclically (yellow) or provided acyclically (green).		At least the DevState is to be evaluated for the most recent cycle in the PLC. The EtherCAT Master's diagnostic information offers many more possibilities than are treated in the EtherCAT System Documentation. A few keywords: <ul style="list-style-type: none"> • CoE in the Master for communication with/through the Slaves • Functions from <i>TcEtherCAT.lib</i> • Perform an OnlineScan
B	In the example chosen (EL3102) the EL3102 comprises two analogue input channels that transmit a single function status for the most recent cycle.	Status <ul style="list-style-type: none"> • the bit significations may be found in the device documentation • other devices may supply more information, or none that is typical of a slave 	In order for the higher-level PLC task (or corresponding control applications) to be able to rely on correct data, the function status must be evaluated there. Such information is therefore provided with the process data for the most recent cycle.

Code	Function	Implementation	Application/evaluation
C	<p>For every EtherCAT Slave that has cyclic process data, the Master displays, using what is known as a WorkingCounter, whether the slave is participating successfully and without error in the cyclic exchange of process data. This important, elementary information is therefore provided for the most recent cycle in the System Manager</p> <ol style="list-style-type: none"> at the EtherCAT Slave, and, with identical contents as a collective variable at the EtherCAT Master (see Point A) <p>for linking.</p>	<p>WcState (Working Counter)</p> <p>0: valid real-time communication in the last cycle</p> <p>1: invalid real-time communication</p> <p>This may possibly have effects on the process data of other Slaves that are located in the same SyncUnit</p>	<p>In order for the higher-level PLC task (or corresponding control applications) to be able to rely on correct data, the communication status of the EtherCAT Slave must be evaluated there. Such information is therefore provided with the process data for the most recent cycle.</p>
D	<p>Diagnostic information of the EtherCAT Master which, while it is represented at the slave for linking, is actually determined by the Master for the Slave concerned and represented there. This information cannot be characterized as real-time, because it</p> <ul style="list-style-type: none"> is only rarely/never changed, except when the system starts up is itself determined acyclically (e.g. EtherCAT Status) 	<p>State</p> <p>current Status (INIT..OP) of the Slave. The Slave must be in OP (=8) when operating normally.</p> <p><i>AdsAddr</i></p> <p>The ADS address is useful for communicating from the PLC/task via ADS with the EtherCAT Slave, e.g. for reading/writing to the CoE. The AMS-NetID of a slave corresponds to the AMS-NetID of the EtherCAT Master; communication with the individual Slave is possible via the <i>port</i> (= EtherCAT address).</p>	<p>Information variables for the EtherCAT Master that are updated acyclically. This means that it is possible that in any particular cycle they do not represent the latest possible status. It is therefore possible to read such variables through ADS.</p>



Attention

Diagnostic information

It is strongly recommended that the diagnostic information made available is evaluated so that the application can react accordingly.

CoE Parameter Directory

The CoE parameter directory (CanOpen-over-EtherCAT) is used to manage the set values for the slave concerned. Changes may, in some circumstances, have to be made here when commissioning a relatively complex EtherCAT Slave. It can be accessed through the TwinCAT System Manager, see Fig. "EL3102, CoE directory":

Index	Name	Flags	Value
6010:0	AI Inputs Ch.2	RO	> 17 <
6401:0	Channels	RO	> 2 <
8000:0	AI Settings Ch.1	RW	> 24 <
8000:01	Enable user scale	RW	FALSE
8000:02	Presentation	RW	Signed (0)
8000:05	Siemens bits	RW	FALSE
8000:06	Enable filter	RW	FALSE
8000:07	Enable limit 1	RW	FALSE
8000:08	Enable limit 2	RW	FALSE
8000:0A	Enable user calibration	RW	FALSE
8000:0B	Enable vendor calibration	RW	TRUE

Fig. 91: EL3102, CoE directory

 Note	<p>EtherCAT System Documentation</p> <p>The comprehensive description in the EtherCAT System Documentation (EtherCAT Basics --> CoE Interface) must be observed!</p>
--	--

A few brief extracts:

- Whether changes in the online directory are saved locally in the slave depends on the device. EL terminals (except the EL66xx) are able to save in this way.
- The user must manage the changes to the StartUp list.

Commissioning aid in the TwinCAT System Manager

Commissioning interfaces are being introduced as part of an ongoing process for EL/EP EtherCAT devices. These are available in TwinCAT System Managers from TwinCAT 2.11R2 and above. They are integrated into the System Manager through appropriately extended ESI configuration files.

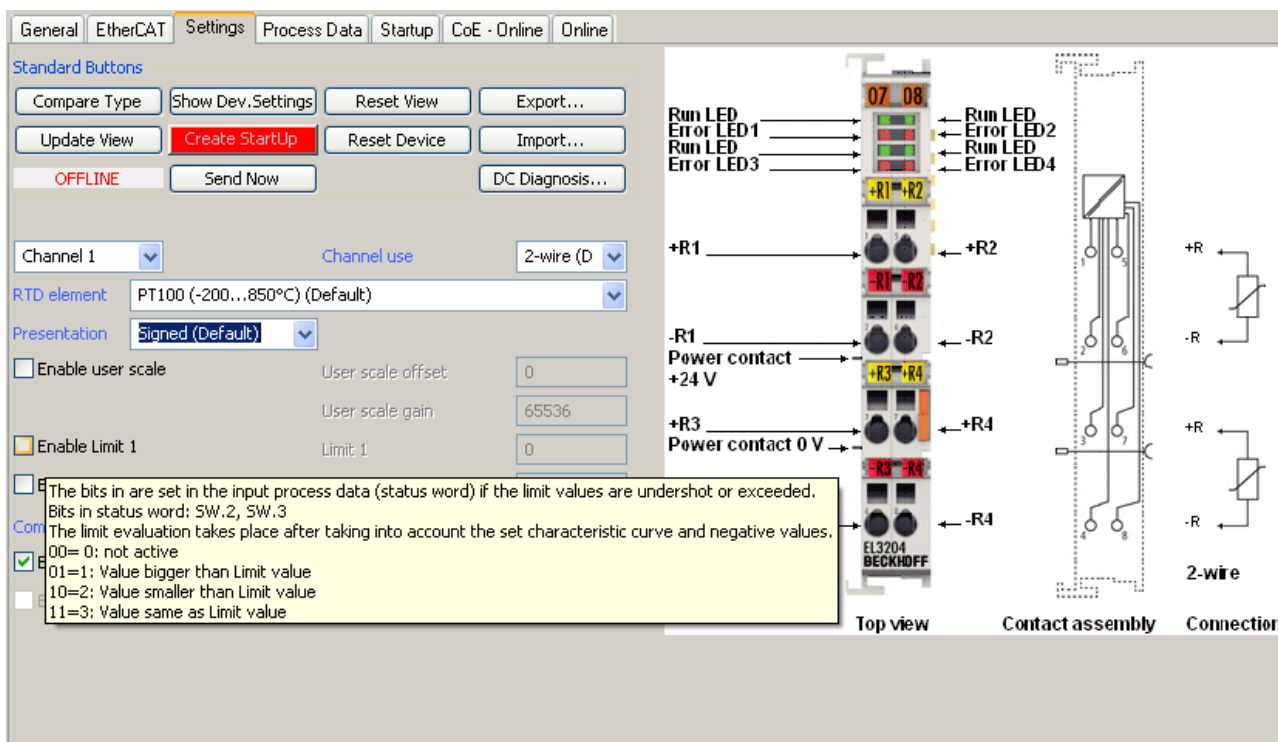

Fig. 92: Example of commissioning aid for a EL3204

This commissioning process simultaneously manages

- CoE Parameter Directory
- DC/FreeRun mode
- the available process data records (PDO)

Although the "Process Data", "DC", "Startup" and "CoE-Online" that used to be necessary for this are still displayed, it is recommended that, if the commissioning aid is used, the automatically generated settings are not changed by it.

The commissioning tool does not cover every possible application of an EL/EP device. If the available setting options are not adequate, the user can make the DC, PDO and CoE settings manually, as in the past.

EtherCAT State: automatic default behaviour of the TwinCAT System Manager and manual operation

After the operating power is switched on, an EtherCAT Slave must go through the following statuses

- INIT
- PREOP
- SAFEOP
- OP

to ensure sound operation. The EtherCAT Master directs these statuses in accordance with the initialization routines that are defined for commissioning the device by the ES/XML and user settings (Distributed Clocks (DC), PDO, CoE). See also the section on "Principles of [Communication, EtherCAT State Machine \[► 21\]](#)" in this connection. Depending how much configuration has to be done, and on the overall communication, booting can take up to a few seconds.

The EtherCAT Master itself must go through these routines when starting, until it has reached at least the OP target state.

The target state wanted by the user, and which is brought about automatically at start-up by TwinCAT, can be set in the System Manager. As soon as TwinCAT reaches the status RUN, the TwinCAT EtherCAT Master will approach the target states.

Standard setting

The advanced settings of the EtherCAT Master are set as standard:

- EtherCAT Master: OP
- Slaves: OP
This setting applies equally to all Slaves.

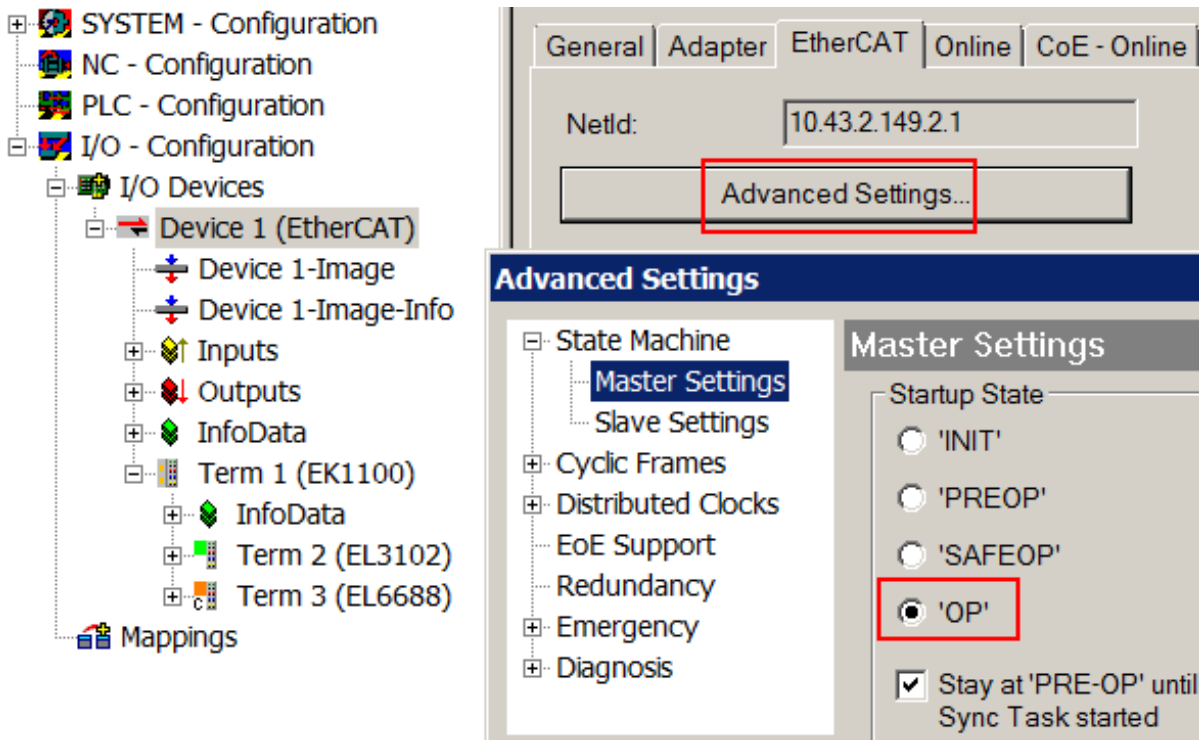

Fig. 93: Default behaviour of the System Manager

In addition, the target state of any particular Slave can be set in the "Advanced Settings" dialogue; the standard setting is again OP.

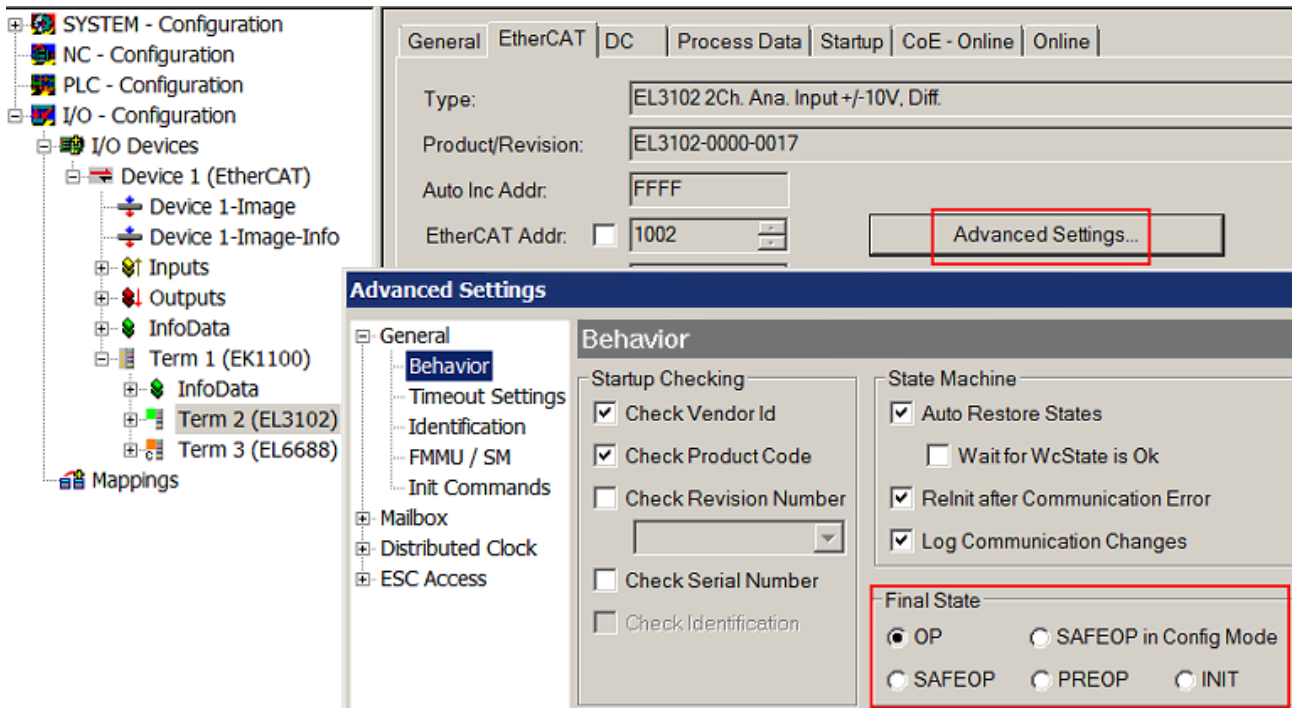

Fig. 94: Default target state in the Slave

Manual Control

There are particular reasons why it may be appropriate to control the states from the application/task/PLC. For instance:

- for diagnostic reasons
- to induce a controlled restart of axes
- because a change in the times involved in starting is desirable

In that case it is appropriate in the PLC application to use the PLC function blocks from the *TcEtherCAT.lib*, which is available as standard, and to work through the states in a controlled manner using, for instance, *FB_EcSetMasterState*.

It is then useful to put the settings in the EtherCAT Master to INIT for master and slave.

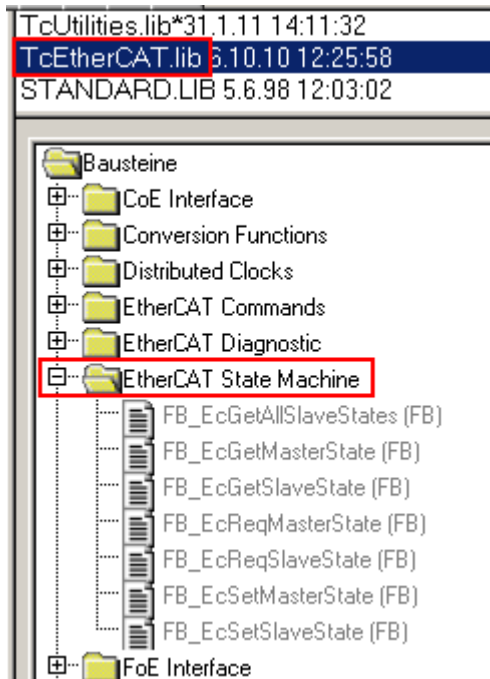

Fig. 95: PLC function blocks

Note regarding E-Bus current

EL/ES terminals are placed on the DIN rail at a coupler on the terminal strand. A Bus Coupler can supply the EL terminals added to it with the E-bus system voltage of 5 V; a coupler is thereby loadable up to 2 A as a rule. Information on how much current each EL terminal requires from the E-bus supply is available online and in the catalogue. If the added terminals require more current than the coupler can supply, then power feed terminals (e.g. EL9410) must be inserted at appropriate places in the terminal strand.

The pre-calculated theoretical maximum E-Bus current is displayed in the TwinCAT System Manager as a column value. A shortfall is marked by a negative total amount and an exclamation mark; a power feed terminal is to be placed before such a position.

General Adapter EtherCAT Online CoE - Online						
NetId:		10.43.2.149.2.1		Advanced Settings...		
Number	Box Name	Address	Type	In Size	Out S...	E-Bus (..
1	Term 1 (EK1100)	1001	EK1100			
2	Term 2 (EL3102)	1002	EL3102	8.0		1830
3	Term 4 (EL2004)	1003	EL2004		0.4	1730
4	Term 5 (EL2004)	1004	EL2004		0.4	1630
5	Term 6 (EL7031)	1005	EL7031	8.0	8.0	1510
6	Term 7 (EL2808)	1006	EL2808		1.0	1400
7	Term 8 (EL3602)	1007	EL3602	12.0		1210
8	Term 9 (EL3602)	1008	EL3602	12.0		1020
9	Term 10 (EL3602)	1009	EL3602	12.0		830
10	Term 11 (EL3602)	1010	EL3602	12.0		640
11	Term 12 (EL3602)	1011	EL3602	12.0		450
12	Term 13 (EL3602)	1012	EL3602	12.0		260
13	Term 14 (EL3602)	1013	EL3602	12.0		70
14	Term 3 (EL6688)	1014	EL6688	22.0		-240 !

Fig. 96: Illegally exceeding the E-Bus current

From TwinCAT 2.11 and above, a warning message "E-Bus Power of Terminal..." is output in the logger window when such a configuration is activated:

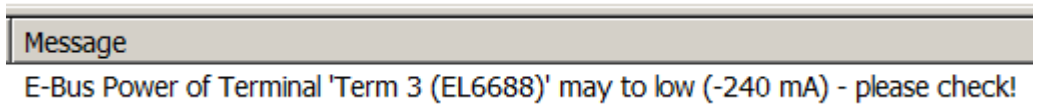



Fig. 97: Warning message for exceeding E-Bus current

 Attention	<p>Caution! Malfunction possible!</p> <p>The same ground potential must be used for the E-Bus supply of all EtherCAT terminals in a terminal block!</p>
---	--

6.4 Basic function principles



Note

RMS value (rms) specifications

All AC value specifications in this documentation such as RMS specifications (r_{ms}) refer to a 50/60 Hz 3-phase mains network with a sinusoidal waveform.

The EL3773 has 6 analog input channels which are measured simultaneously in their respective measuring ranges. The properties are discussed below in the order of the data processing.

Input filter

Each channel has a 5th order low-pass filter with Bessel characteristic which can be parameterized via the CoE setting `0x8000:15` [▶ 95]. The corresponding anti-aliasing filters are placed up or downstream and are adapted automatically.

The filter setting of channel 1 also applies to channels 2 to 6; the corresponding CoE object cannot be written in these channels. All 6 input channels are thus subject to the same filter characteristic.

The input filter cannot be deactivated.

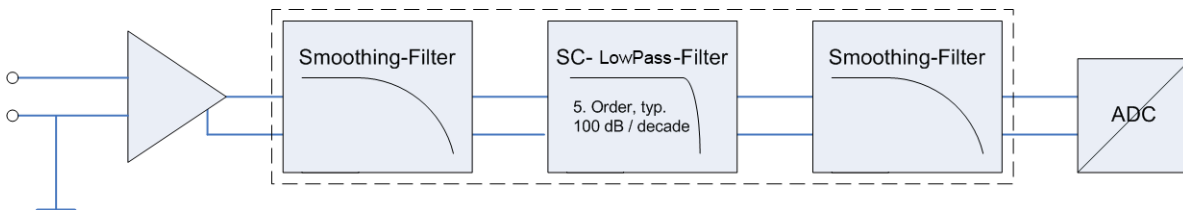

Fig. 98: Data flow diagram input filter

The following steps can be selected:

- 200 Hz
- 500 Hz
- 1 kHz
- 1.5 kHz
- 2.5 kHz
- 5 kHz
- 15 kHz

Index	Name	Flags	Value
8000:0	AI Settings	RW	> 33 <
8000:07	Enable limit	RW	FALSE
8000:0A	Enable user calibration	RW	FALSE
8000:0B	Enable vendor calibration	RW	TRUE
8000:13	Limit 1	RW	29490
8000:14	Limit 2	RW	32767
8000:15	Filter settings	RW	5000 Hz (5)
8000:17	User calibration offset	RW	0
8000:18	User calibration gain	RW	16384
8010:0	AI Settings	RW	> 33 <
8020:0	AI Settings	RW	> 33 <
8030:0	AI Settings	RW	> 33 <
8040:0	AI Settings	RW	> 33 <
8050:0	AI Settings	RW	> 33 <

Set Value Dialog

Dec: OK

Hex: Cancel

Enum: 5000 Hz (selected)

200 Hz

500 Hz

1000 Hz

1500 Hz

2500 Hz

5000 Hz

15000 Hz

Bit Size: Edit...

Fig. 99: Filter setting via the CoE object "Filter settings" (Index 0x8000:15)

The amplitude curve can be represented accordingly:

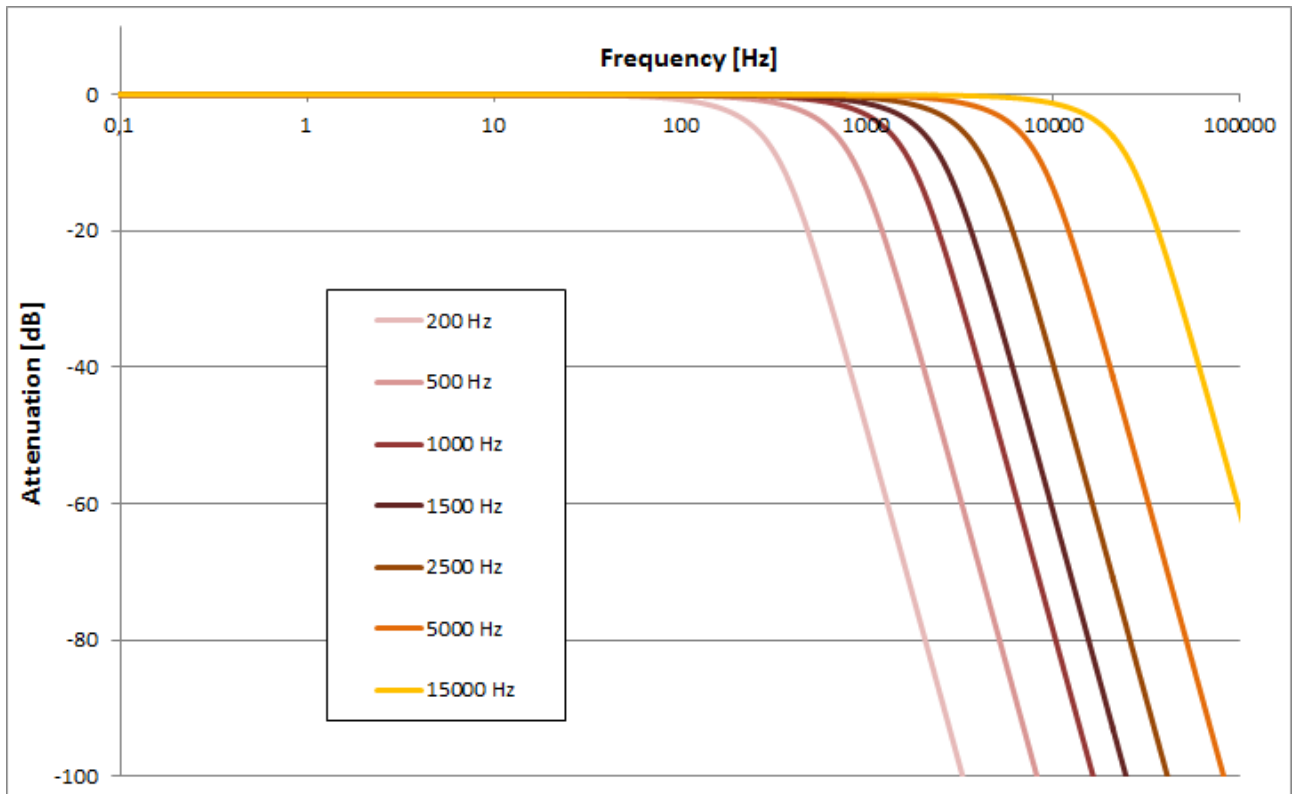



Fig. 100: Amplitude curve

 Note	<p>Changes in the CoE directory</p> <p>In case of changes to the CoE default parameters, it is essential that corresponding values are entered in the start-up list, so that in the case of exchange the EL3773 operates again as foreseen in the application.</p>
--	---

6.5 Process data

Table of contents
• Data flow [▶ 86]
• Data processing [▶ 87]
• Predefined PDO Assignment [▶ 89]
• Process image [▶ 90]
• Control/status word [▶ 91]
• Synchronization and conversion time [▶ 92]

Data flow

The amplitude values are measured with 16-bit resolution and provided as oversampling packets in the process image for cyclic transmission.

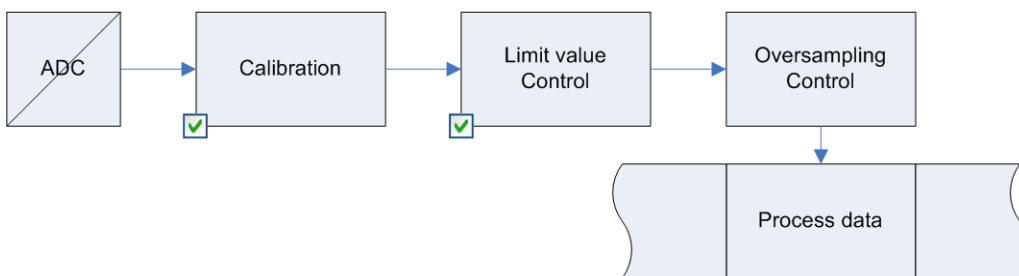

Fig. 101: Process data flow EL3773

Data processing

The data processing is done simultaneously for all channels in the EL3773 with 16-bit conversion in the ADC. Scaling related to the respective (constant) measuring range:

1. Vendor calibration (0x80p0:0B [▶ 95])

Activation: CoE 0x80p0:0B

$$X_1 = (X_{ADC} - \text{Offset}_{Vendor}) * \text{Gain}_{Vendor}$$

This produces the following signed integer value representation:

Input signal		Value	
Voltage	Current	Decimal	Hexadecimal
410 V	1.5 A	32767	0x7FFF
205 V	0.75 A	16383	0x3FFF
0 V	0 A	0	0x0000
-205 V	-0.75 A	-16383	0xC001
-410 V	-1.5 A	-32767	0x8000

Signed integer: the negative output value is represented in two's complement (negated + 1). Maximum representation range for 16 bits = -32768 to +32767_{dec}.

2. User calibration (0x80p0:0A [▶ 95])

Activation: CoE 0x80n0:0A

$$X_2 = (X_1 - \text{Offset}_{User}) * \text{Gain}_{User}$$

3. Limit value evaluation (0x80p0:13 [▶ 95], 0x80p0:14 [▶ 95])

Display in the [status word \[▶ 91\]](#) of the channel

If the value exceeds or falls below these values, which can be entered in the indices [0x80p0:13 \[▶ 95\]](#) and [0x80p0:14 \[▶ 95\]](#), then the bits in the indices [0x60p0:03 \[▶ 96\]](#) and [0x60p0:05 \[▶ 96\]](#) are set accordingly (see [example \[▶ 87\]](#) below).

The entry [0x80p0:07 \[▶ 95\]](#) serves to activate the limit value monitoring.

Output limit n (2-bit):

- 0: not active
- 1: One or more values <= Limit n
- 2: One or more values >= Limit n
- 3: Cases 1 and 2 simultaneously



Note

Linking in the PLC with 2-bit values

The limit information consists of 2 bits. *Limitn* can be linked to the PLC or a task in the System Manager:

- PLC: IEC61131-PLC contains no 2-bit data type that can be linked with this process data directly. In order to transmit the limit information, therefore, define an input byte, e.g.

```
VAR
    byLimit1 AT %I*:BYTE;
END_VAR
```

and link the limit with the *VariableSizeMismatch* dialog.

- Additional task
2-bit variables can be created in the System Manager.

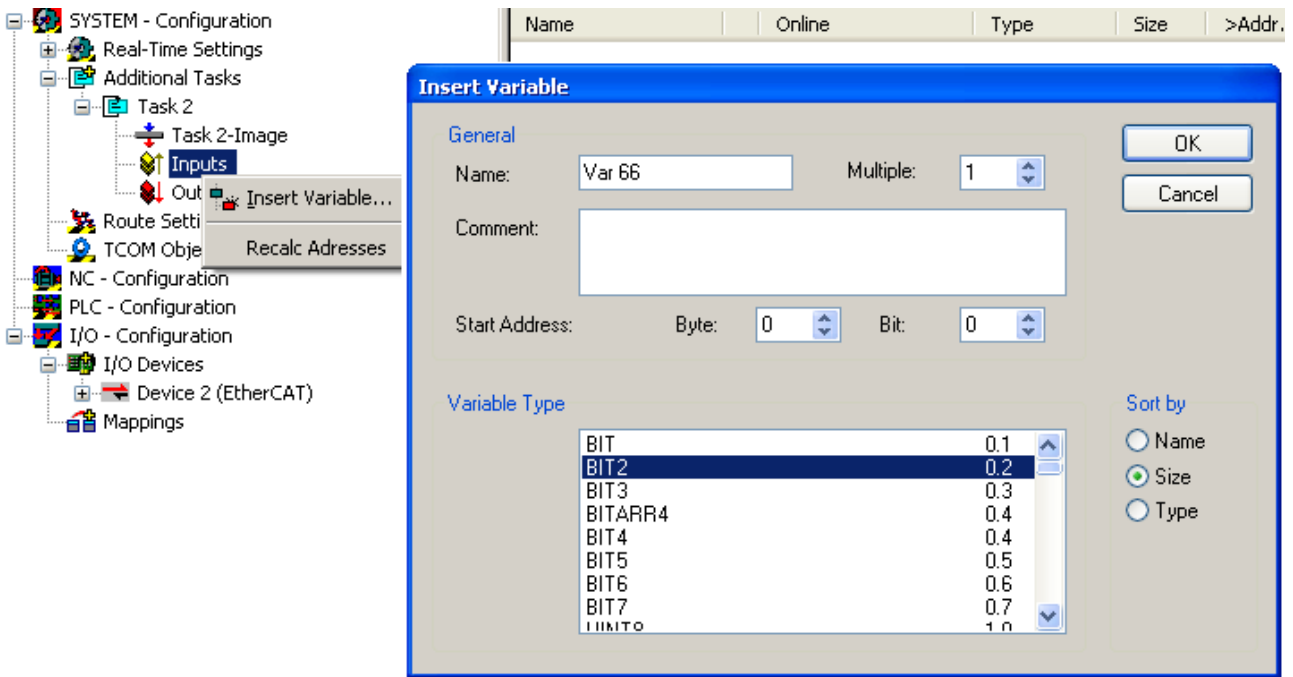

Fig. 102: Linking of 2-bit variable to additional task

Example of voltage measurement with EL3773:

Channel 1; Limit 1 and Limit 2 enabled, Limit 1 = 100 V, Limit 2 = 200 V, representation: signed integer

Entry in index (Limit 1): [0x8000:13 \[► 95\]](#)
 $(100 \text{ V} / 410 \text{ V}) \times 2^{16} / 2 - 1 = 7991_{\text{dec}}$

Entry in index (Limit 2): [0x8000:14 \[► 95\]](#)
 $(200 \text{ V} / 410 \text{ V}) \times 2^{16} / 2 - 1 = 15983_{\text{dec}}$

Output:

Input channel 1	Index 0x6000:03 [► 96]	Index 0x6000:05 [► 96]
50 V	0x01 _{hex} , (Limit 1, limit value undershot)	0x01 _{hex} , (Limit 2, limit value undershot)
100 V	0x03 _{hex} , (Limit 1, limit value reached)	0x01 _{hex} , (Limit 2, limit value undershot)
150 V	0x02 _{hex} , (Limit 1, limit value exceeded)	0x01 _{hex} , (Limit 2, limit value undershot)
210 V	0x02 _{hex} , (Limit 1, limit value exceeded)	0x02 _{hex} , (Limit 2, limit value exceeded)

4. Provision in the process data

The influencing parameters can be changed in the CoE of the respective channel.

8000:0	AI Settings	RW	> 33 <
8000:07	Enable limit	RW	FALSE
8000:0A	Enable user calibration	RW	FALSE
8000:0B	Enable vendor calibration	RW	TRUE
8000:13	Limit 1	RW	29490
8000:14	Limit 2	RW	32767
8000:15	Filter settings	RW	5000 Hz (5)
8000:17	User calibration offset	RW	0
8000:18	User calibration gain	RW	16384
8010:0	AI Settings	RW	> 33 <

Fig. 103: User settings and vendor calibration in the CoE online directory

 Note	<p>Changes in the CoE directory</p> <p>In case of changes to the CoE default parameters, it is essential that corresponding values are entered in the start-up list, so that in the case of exchange the EL3773 operates again as foreseen in the application.</p>
--	---

Predefined PDO Assignment

The "Predefined PDO Assignment" enables a simplified selection of the process data.

The desired function is selected on the lower part of the "Process Data" tab. As a result, all necessary PDOs are automatically activated and the unnecessary PDOs are deactivated.

8 PDO assignments are available:

Name	SM3, PDO assignment, meaning
Synchronous	0x1A00, 0x1A01, 0x1A10, 0x1A11, 0x1A20, 0x1A21, 0x1A30, 0x1A31, 0x1A40, 0x1A41, 0x1A50, 0x1A51 "Synchronous"
Synchronous oversampling 2	0x1A00, 0x1A02, 0x1A10, 0x1A12, 0x1A20, 0x1A22, 0x1A30, 0x1A32, 0x1A40, 0x1A42, 0x1A50, 0x1A52 0x1A61 "Synchronous, with 2-fold oversampling"
Synchronous oversampling 4	0x1A00, 0x1A03, 0x1A10, 0x1A13, 0x1A20, 0x1A23, 0x1A30, 0x1A33, 0x1A40, 0x1A43, 0x1A50, 0x1A53 0x1A61 "Synchronous, with 4-fold oversampling"
Synchronous oversampling 8	0x1A00, 0x1A05, 0x1A10, 0x1A15, 0x1A20, 0x1A25, 0x1A30, 0x1A35, 0x1A40, 0x1A45, 0x1A50, 0x1A55 0x1A61 "Synchronous, with 8-fold oversampling"
Synchronous oversampling 16	0x1A00, 0x1A07, 0x1A10, 0x1A17, 0x1A20, 0x1A27, 0x1A30, 0x1A37, 0x1A40, 0x1A47, 0x1A50, 0x1A57 0x1A61 "Synchronous, with 16-fold oversampling"
Synchronous oversampling 32	0x1A00, 0x1A0A, 0x1A10, 0x1A1A, 0x1A20, 0x1A2A, 0x1A30, 0x1A3A, 0x1A40, 0x1A4A, 0x1A50, 0x1A5A 0x1A61 "Synchronous, with 32-fold oversampling"
Synchronous oversampling 64	0x1A00, 0x1A0D, 0x1A10, 0x1A1D, 0x1A20, 0x1A2D, 0x1A30, 0x1A3D, 0x1A40, 0x1A4D, 0x1A50, 0x1A5D 0x1A61 "Synchronous, with 64-fold oversampling"
DC (activate Mode on DC tab)	0x1A00, 0x1A05, 0x1A10, 0x1A15, 0x1A20, 0x1A25, 0x1A30, 0x1A35, 0x1A40, 0x1A45, 0x1A50, 0x1A55 0x1A60, 0x1A61 "Distributed Clocks, settings via DC tab [► 92]"

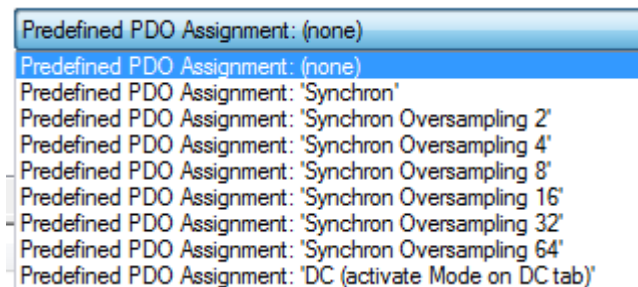

Fig. 104: EL3773 Selection dialog "Predefined PDO Assignment"

Process image

The EL3773 is inserted into the configuration by default with the 10-fold oversampling process image and DC timestamp:

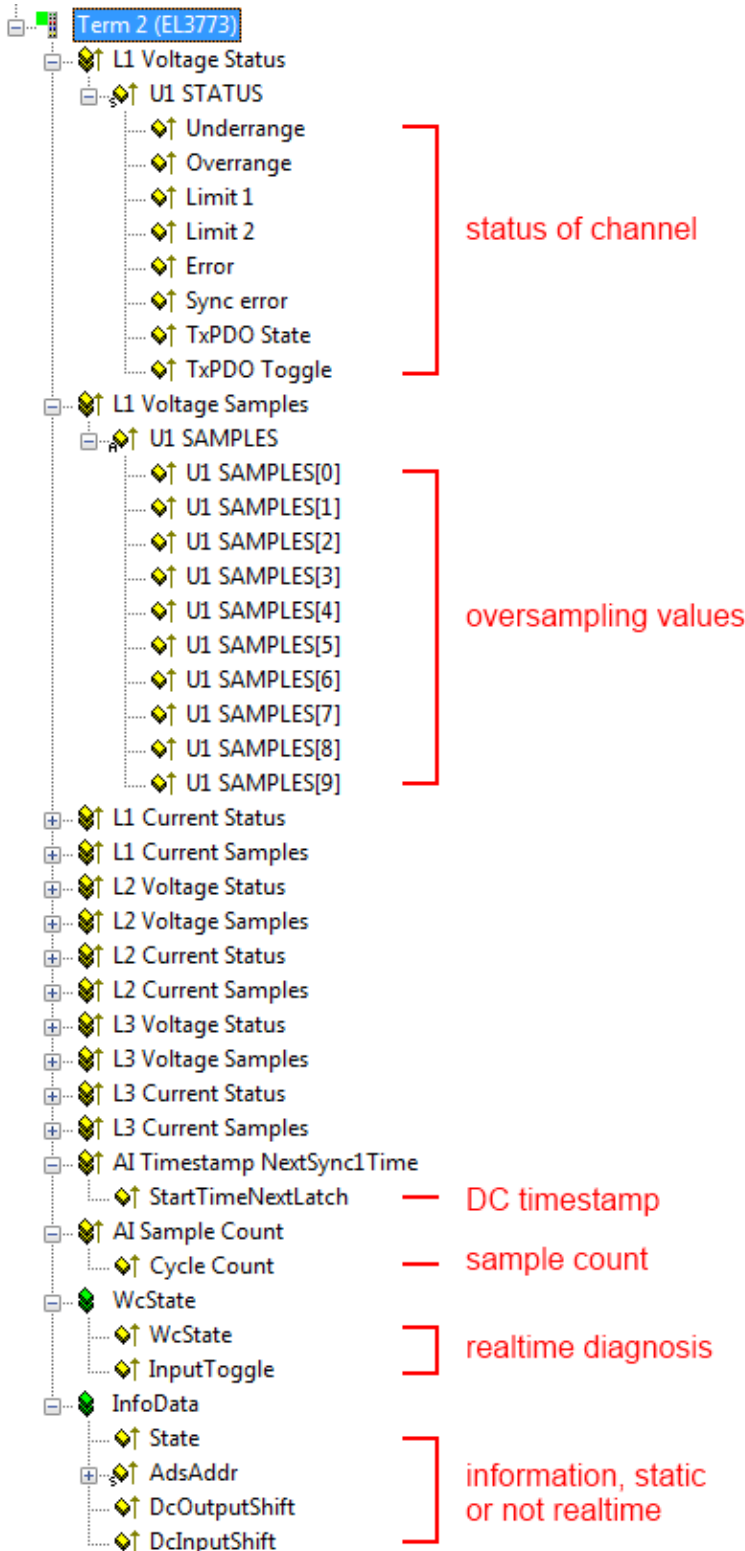

Fig. 105: Process image of the EL3773 in the TwinCAT System Manager

It is urgently recommended to evaluate the offered diagnostic values in the controller, e.g. see the [Notes page \[p. 76\]](#).

In particular the EL3773 offers the following cyclic information:

Variable	Meaning
Status word	See below [► 91]
Overrange	Value after calibration > 0x7FFF
Underrange	Value after calibration < 0x8000
SyncError	- In DC mode: indicates whether a synchronization error occurred in the expired cycle. This means a SYNC signal was triggered in the terminal, although no new process data were available (0=OK, 1=NOK). - Error in the synchronous oversampling, e.g. the number of ADC values and the number of PDO values do not match.
StartTimeNextLatch	In the 64-bit-wide process data <i>StartTimeNextLatch</i> , as was also the case with previous EL37xx terminals, the time is specified in each process data cycle when the <i>next</i> SYNC1 pulse and thus the next block of sample values begins, referenced to the currently transmitted block. <i>StartTimeNextLatch</i> thus changes in each cycle by the amount of that task cycle time with which this terminal is operated. This time specification is based on the terminal's local Distributed Clocks time. By means of this time specification a concrete time can to be assigned to each individual sample with the known oversampling factor. Example: With a cycle time of 1 ms (= 1,000,000 ns) and an oversampling factor of 10 in the regarded cycle, the EL3773 supplies a $StartTimeNextLatch = 7,777,216_{dec}$ and 6 x 10 measured values at 16 bits each as process data (3 x U, 3 x I). The time of measurement of the 5 th supplied sample is now to be determined, i.e. the Distributed Clocks time at which the 5 th sample was determined. The currently supplied set of 10 samples was started at the time $7,777,216 - 1,000,000$ (cycle time) = 6,777,216 ns. The time interval between the samples is $1,000,000 / 10 = 100,000$ ns. Hence, the 5 th sample was determined at the time $6,777,216 + ((5 - 1) * 100,000) = 7,177,216$ ns.
Cycle Count	The cycle counter is incremented by one unit with each process data cycle. The CycleCounter enables the higher-level controller to check whether a data record has possibly been omitted or transmitted twice. In that case the DC shift time of the terminal usually has to be adapted.
DcOutputShift, DcInputShift	In these static variables the System Manager announces the shift time to which this terminal has been set. The value is set once on activating/calculating the configuration and also depends on the customer-specific settings in the extended slave settings. It can be linked to offset calculations in the PLC.

Control/status word

Status word

The status word (SW) is located in the input process image, and is transmitted from terminal to the controller.

Bit	SW.15	SW.14	SW.13	SW.12	SW.11	SW.10	SW.9	SW.8
Name	TxPDO Toggle	TxPDO State	Sync error	-	-	-	-	-

Bit	SW.7	SW.6	SW.5	SW.4	SW.3	SW.2	SW.1	SW.0
Name	-	ERROR	Limit 2		Limit 1		Overrange	Underrange

Table 1: Legend

Bit	Name	Description
SW.15	TxPDO Toggle	1 _{bin} Toggles with each new analog process value
SW.14	TxPDO State	1 _{bin} TRUE in the case of an internal error
SW.13*	Sync error	1 _{bin} TRUE (DC mode): a synchronization error occurred in the expired cycle.
SW.6	ERROR	1 _{bin} General error bit, is also set together with overrange and underrange

Bit	Name	Description	
SW.5	Limit 2	1 _{bin}	See Limit [► 96]
SW.4		1 _{bin}	
SW.3	Limit 1	1 _{bin}	See Limit [► 96]
SW.2		1 _{bin}	
SW.1	Overrange	1 _{bin}	Analog input signal lies above the upper permissible threshold for this terminal
SW.0	Underrange	1 _{bin}	Analog input signal lies under the lower permissible threshold for this terminal

Control word

The EL3773 has no control word

Synchronization, trigger and conversion time

The EL3773 generally operates in oversampling mode. It can be operated with and without Distributed Clocks activated.

Distributed Clocks activated

- the EtherCAT system-wide synchronized Distributed Clocks also encompass this EL3773
- the terminal then operates synchronously with all other DC devices
- the sampling clock is derived from the local DC in the EtherCAT slave controller (SYNC0: Oversampling, SYNC1: Provision of the data)

Advantages

- several EL3773 record the measured values of all their channels synchronously
- accurate time stamp of the individual samples

The following limit values are to be observed

- minimum sampling time 100 μ s (10,000 kSps)
- only non-periodic values are permissible for the sampling rate
- the PDO StartTimeNextlatch can only be used/activated with cycle times > 100 μ s

Table of sampling times

Sampling Time	Cycle time / μ s							
	100	200	250	500	1000	2000	5000	10000
1	100 μ s	200 μ s	250 μ s	500 μ s	1000 μ s	2000 μ s	5000 μ s	10000 μ s
2		100 μ s	125 μ s	250 μ s	500 μ s	1000 μ s	2500 μ s	5000 μ s
4			125 μ s	250 μ s	500 μ s	1000 μ s	1250 μ s	2500 μ s
5				100 μ s	200 μ s	400 μ s	1000 μ s	2000 μ s
8					125 μ s	250 μ s	625 μ s	1250 μ s
10					100 μ s	200 μ s	500 μ s	1000 μ s
16						125 μ s	312,5 μ s	625 μ s
20						100 μ s	250 μ s	500 μ s
25							200 μ s	400 μ s
32							156,25 μ s	312,5 μ s
40							125 μ s	250 μ s
50							100 μ s	200 μ s
64								156,25 μ s
80								125 μ s
100								100 μ s

Fig. 106: Samplingtime

The minimum EtherCAT cycle time for the EL3773 is 100 μ s. In order to activate Distributed Clocks, "DC" is to be selected in the Predefined PDO list, so that amongst others the time stamp PDO is selected

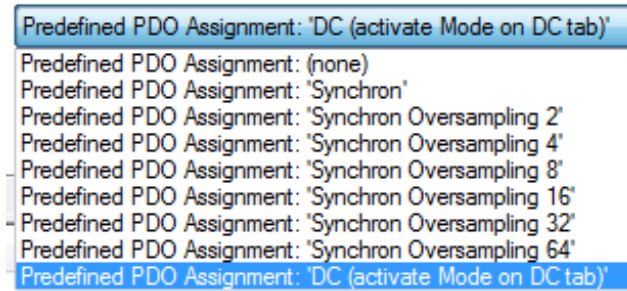

Fig. 107: EL3773 Selection dialog "Predefined PDO Assignment"

The permissible oversampling rates are set via the System Manager *DC* tab:

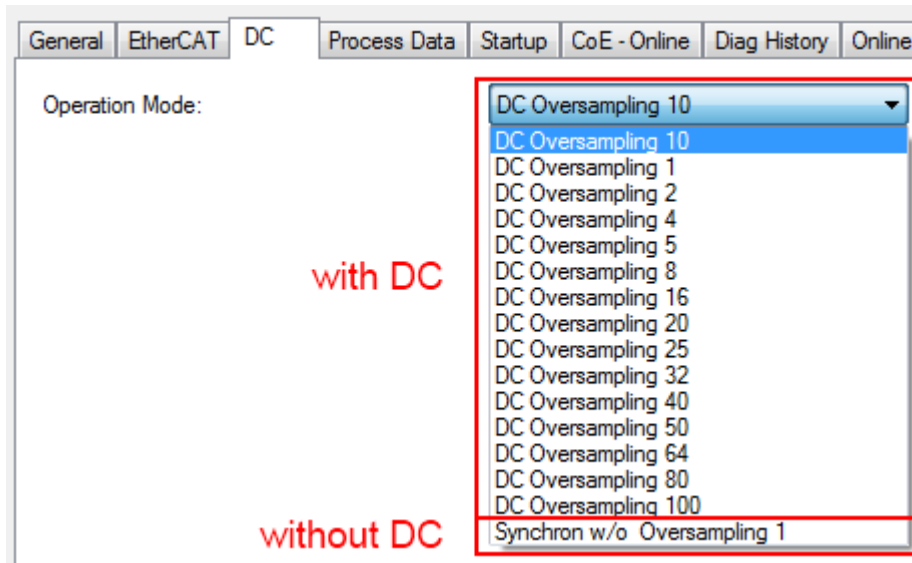

Fig. 108: Setting of the oversampling rates via System Manager, "DC" tab

Distributed Clocks not activated

- the EL3773 operates according to an internal clock, which is synchronized to the EtherCAT cycle time. The trigger point in this case is the access to the input Sync Manager SM3.
- As a result the EL3773 can compensate fluctuations in the cycle time to a large extent
- The EL3773 can thus be used in systems that have no Distributed Clocks functionality. The time accuracy of the measured values is reduced, however.

The EtherCAT cycle time must be selected such that

- it is not less than 100 µs
- the oversampling interval does not produce a non-periodic time value – for example, 33.3 µs is not allowed for the oversampling cycle

The Distributed Clock is to be deactivated in the *DC* tab

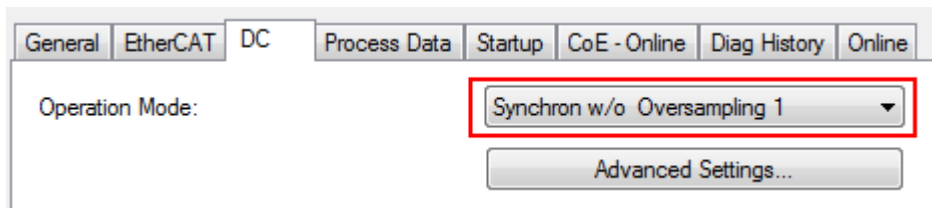

Fig. 109: Deactivation of the Distributed Clock in the "DC" tab

The permissible oversampling rates are then set via the System Manager:

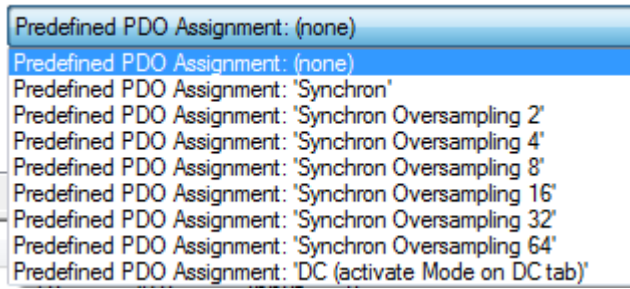



Fig. 110: EL3773 Selection dialog "Predefined PDO Assignment"

6.6 Object description and parameterization

 Note	<p>EtherCAT XML Device Description</p> <p>The display matches that of the CoE objects from the EtherCAT <u>XML Device Description</u>. We recommend downloading the latest XML file from the download area of the Beckhoff website and installing it according to installation instructions.</p>
 Note	<p>Parameterization via the CoE list (CAN over EtherCAT)</p> <p>The EtherCAT device is parameterized via the <u>CoE - Online tab [▶ 71]</u> (double-click on the respective object) or via the <u>Process Data tab [▶ 68]</u>(allocation of PDOs). Please note the following general <u>CoE notes [▶ 23]</u> when using/manipulating the CoE parameters:</p> <ul style="list-style-type: none"> - Keep a startup list if components have to be replaced - Differentiation between online/offline dictionary, existence of current XML description - use "CoE reload" for resetting changes

Introduction

The CoE overview contains objects for different intended applications:

- Objects required for parameterization during commissioning:
 - Restore object index 0x1011
 - Configuration data index 0x80n0
- Objects intended for regular operation, e.g. through ADS access.
- Profile-specific objects:
 - Configuration data (vendor-specific) index 0x80nF
 - Input data index 0x60n0
 - Information and diagnostic data index 0x80nE, 0xF000, 0xF008, 0xF010
- Standard objects

The following section first describes the objects required for normal operation, followed by a complete overview of missing objects.

6.6.1 Restore object

Index 1011 Restore default parameters

Index (hex)	Name	Meaning	Data type	Flags	Default
1011:0	Restore default parameters [▶ 172]	Restore default parameters	UINT8	RO	> 1 <
1011:01	SubIndex 001	If this object is set to "0x64616F6C" in the set value dialog, all backup objects are reset to their delivery state.	UINT32	RW	0x00000000 (0 _{dec})

6.6.2 Configuration data

Index 80p0 AI Settings (for p = 0...5, corresponding to channel 1...6)

Index (hex)	Name	Meaning	Data type	Flags	Default
80p0:0	AI Settings	Maximum subindex	UINT8	RO	> 24 <
80p0:07	Enable limit [▶ 87]	Limit 1 enabled	BOOLEAN	RW	FALSE
80p0:0A	Enable user calibration [▶ 87]	Enabling of the user calibration	BOOLEAN	RW	FALSE
80p0:0B	Enable vendor calibration [▶ 87]	Enabling of the vendor calibration	BOOLEAN	RW	TRUE
80p0:13	Limit 1 [▶ 87]	First limit value for setting the status bits	INT16	RW	0 _{dec}
80p0:14	Limit 2 [▶ 87]	Second limit value for setting the status bits	INT16	RW	0 _{dec}
80p0:15	Filter settings [▶ 85]	This object determines the digital filter settings. The possible settings are sequentially numbered. 0: 200 Hz 1: 500 Hz 2: 1000 Hz 3: 1500 Hz 4: 2500 Hz 5: 5000 Hz 6: 15000 Hz See note below:	UINT16	RW	2500 Hz (4)
80p0:17	User calibration offset [▶ 87]	User calibration offset	INT16	RW	0 _{dec}
80p0:18	User calibration gain [▶ 87]	User calibration gain	INT16	RW	16384 _{dec}



Note

The filter characteristics are set via index 0x8000:15

The filter frequencies are set for all channels centrally via index 0x8000:15 (channel 1). All other corresponding indices 0x80p0:15 have no parameterization function!

Index 80pF AI Vendor data (for p = 0...5, corresponding to channel 1...6)

Index (hex)	Name	Meaning	Data type	Flags	Default
80pF:0	AI Vendor data	Maximum subindex	UINT8	RO	> 2 <
80pF:01	Calibration offset	Offset (vendor calibration)	INT16	RW	-
80pF:02	Calibration gain	Gain (vendor calibration)	INT16	RW	-

6.6.3 Input data

Index 60p0 AI Inputs (for p = 0...5, corresponding to channel 1...6)

Index (hex)	Name	Meaning	Data type	Flags	Default
60p0:0	Status	Maximum subindex	UINT8	RO	> 16 <
60p0:01	Underrange	Value below measuring range.	BOOLEAN	RO	FALSE
60p0:02	Overrange	Measuring range exceeded.	BOOLEAN	RO	FALSE
60p0:03	Limit 1	Limit value monitoring Limit 1 0: not active 1: One or more values <= Limit 1 2: One or more values >= Limit 1 3: Cases 1 and 2 simultaneously	BIT2	RO	0x00 (0 _{dec})
60p0:05	Limit 2	Limit value monitoring Limit 2 0: not active 1: One or more values <= Limit 2 2: One or more values >= Limit 2 3: Cases 1 and 2 simultaneously	BIT2	RO	0x00 (0 _{dec})
60p0:07	Error	The error bit is set if the data is invalid (over-range, under-range)	BOOLEAN	RO	FALSE
60p0:0E	Sync error	The Sync error bit is only required for DC mode. It indicates whether a synchronization error has occurred during the previous cycle. This means a SYNC signal was triggered in the terminal, although no new process data were available (0=OK, 1=NOK).	BOOLEAN	RO	FALSE
60p0:0F	TxPDO State	Validity of the data of the associated TxPDO (0 = valid, 1 = invalid).	BOOLEAN	RO	FALSE
60p0:10	TxPDO Toggle	The TxPDO toggle is toggled by the slave when the data of the associated TxPDO is updated.	BOOLEAN	RO	FALSE

Index 60p2 Samples (for p = 0...5, corresponding to channel 1...6)

Index (hex)	Name	Meaning	Data type	Flags	Default
60p2:0	Samples	Maximum subindex	UINT8	RO	> 100 <
60p2:01	Subindex 001	Sample 001	BOOLEAN	RO	0
...
60p2:64	Subindex 100	Sample 100	BOOLEAN	RO	0

Index 6060 NextSync1 Time

Index (hex)	Name	Meaning	Data type	Flags	Default
6060:0	Next Sync1 Time	Max. subindex	UINT8	RO	> 1 <
6060:01	StartTimeNextLatch [► 90]	see Process data [► 90]	UINT64	RO	00 00 00 00 00 00 00 00

Index 6061 Sample Count

Index (hex)	Name	Meaning	Data type	Flags	Default
6061:0	Sample Count	Max. Subindex	UINT8	RO	> 1 <
6061:01	Cycle Count [► 90]	see Process data [► 90]	UINT16	RO	0x6061:01, 16

6.6.4 Diagnostic data

Index 10F3 Diagnosis History

Index (hex)	Name	Meaning	Data type	Flags	Default
10F3:0	Diagnosis History	Maximum subindex	UINT8	RO	> 21 <
10F3:01	Maximum Messages	Maximum number of stored messages A maximum of 50 messages can be stored	UINT8	RO	0x10 (16 _{dec})
10F3:02	Newest Message	Subindex of the latest message	UINT8	RO	0x00 (0 _{dec})
10F3:03	Newest Acknowledged Message	Subindex of the last confirmed message	UINT8	RW	0x00 (0 _{dec})
10F3:04	New Messages Available	Indicates that a new message is available	BOOLEAN	RO	FALSE
10F3:05	Flags	not used	UINT16	RW	0x0000 (0 _{dec})
10F3:06	Diagnosis Message 001	Message 1	OCTET-STRING[28]	RO	see Diag Messages
...
10F3:15	Diagnosis Message 016	Message 50	OCTET-STRING[28]	RO	-

Index 10F8 Actual Time Stamp

Index (hex)	Name	Meaning	Data type	Flags	Default
10F8:0	Actual Time Stamp	Time stamp	UINT64	RO	-

6.6.5 Standard objects

Index 1000 Device type

Index (hex)	Name	Meaning	Data type	Flags	Default
1000:0	Device type	Device type of the EtherCAT slave: the Lo-Word contains the CoE profile used (5001). The Hi-Word contains the module profile according to the modular device profile.	UINT32	RO	0x012C1389(19665801 _{dec})

Index 1008 Device name

Index (hex)	Name	Meaning	Data type	Flags	Default
1008:0	Device name	Device name of the EtherCAT slave	STRING	RO	EL3773

Index 1009 Hardware version

Index (hex)	Name	Meaning	Data type	Flags	Default
1009:0	Hardware version	Hardware version of the EtherCAT slave	STRING	RO	-

Index 100A Software version

Index (hex)	Name	Meaning	Data type	Flags	Default
100A:0	Software version	Firmware version of the EtherCAT slave	STRING	RO	-

Index 1018 Identity

Index (hex)	Name	Meaning	Data type	Flags	Default
1018:0	Identity	Information for identifying the slave	UINT8	RO	> 4 <
1018:01	Vendor ID	Vendor ID of the EtherCAT slave	UINT32	RO	0x00000002
1018:02	Product code	Product code of the EtherCAT slave	UINT32	RO	0x0EBD3052 (247279698 _{dec})
1018:03	Revision	Revision number of the EtherCAT slave; the low word (bit 0-15) indicates the special terminal number, the high word (bit 16-31) refers to the device description	UINT32	RO	-
1018:04	Serial number	Serial number of the EtherCAT slave; the low byte (bit 0-7) of the low word contains the year of production, the high byte (bit 8-15) of the low word contains the week of production, the high word (bit 16-31) is 0	UINT32	RO	0x00000000

Index 10F0 Backup parameter handling

Index	Name	Meaning	Data type	Flags	Default
10F0:0	Backup parameter handling	Information for standardized loading and saving of backup entries	UINT8	RO	> 1 <
10F0:01	Checksum	Checksum across all backup entries of the EtherCAT slave	UINT32	RO	0x00000000 (0 _{dec})

Index 18pp Analog Input TxPDO-Par Samples (for Ch. 1 ... Ch.6; 01_{hex} ≤ pp ≤ 5F_{hex})

Index (hex)	Name	Meaning	Data type	Flags	Default
18pp:0	AI TxPDO-Par Sample	PDO Parameter TxPDO	UINT8	RO	> 6 <
18pp:06	Exclude TxPDOs	Specifies the TxPDOs (index of TxPDO mapping objects) that must not be transferred together with this PDO	OCTET-STRING[2]	RO	see Predefined PDO Assignment [► 89]

Index 1Ap0 AI TxPDO-Map Status (for p = 0...5; dependent on the number of channels)

Index (hex)	Name	Meaning	Data type	Flags	Default
1Ap0:0	AI TxPDO-Map Status	PDO Mapping TxPDO	UINT8	RO	> 10 <
1Ap0:01	SubIndex 001	1. PDO Mapping entry (object 0x60p0 (AI Inputs), entry 0x01 (Underrange))	UINT32	RO	0x60p0:01, 1
1Ap0:02	SubIndex 002	2. PDO Mapping entry (object 0x60p0 (AI Inputs), entry 0x02 (Overrange))	UINT32	RO	0x60p0:02, 1
1Ap0:03	SubIndex 003	3. PDO Mapping entry (object 0x60p0 (AI Inputs), entry 0x03 (Limit 1))	UINT32	RO	0x60p0:03, 2
1Ap0:04	SubIndex 004	4. PDO Mapping entry (object 0x60p0 (AI Inputs), entry 0x05 (Limit 2))	UINT32	RO	0x60p0:05, 2
1Ap0:05	SubIndex 005	5. PDO Mapping entry (object 0x60p0 (AI Inputs), entry 0x07 (Error))	UINT32	RO	0x60p0:07, 1
1Ap0:06	SubIndex 006	6. PDO Mapping entry (1 bit align)	UINT32	RO	0x0000:00, 1
1Ap0:07	SubIndex 007	7. PDO Mapping entry (5 bits align)	UINT32	RO	0x0000:00, 5
1Ap0:08	SubIndex 008	8. PDO Mapping entry (object 0x60p0 (AI Inputs), entry 0x0E (Sync error))	UINT32	RO	0x60p0:0E, 1
1Ap0:09	SubIndex 009	9. PDO Mapping entry (object 0x60p0 (AI Inputs), entry 0x0F (TxPDO State))	UINT32	RO	0x60p0:0F, 1
1Ap0:0A	SubIndex 010	10. PDO Mapping entry (object 0x60p0 (AI Inputs), entry 0x10 (TxPDO Toggle))	UINT32	RO	0x60p0:10, 1

Index 1Apq AI TxPDO-Map Samples

Index (hex)	Name	Meaning	Data type	Flags	Default																																																																											
1Apq:0	AI TxPDO-Map Samples	<table border="1"> <thead> <tr> <th>n</th> <th>p</th> <th>q</th> </tr> </thead> <tbody> <tr> <td>1_{dec} = Max. Subindex: 001</td> <td>0x0 = L1 Voltage Samples</td> <td>0x1 = 1 Sample</td> </tr> <tr> <td>2_{dec} = Max. Subindex: 002</td> <td></td> <td>0x60p2:01, 16</td> </tr> <tr> <td>4_{dec} = Max. Subindex: 004</td> <td>0x1 = L1 Current Samples</td> <td>0x2 = 2 Samples,</td> </tr> <tr> <td>5_{dec} = Max. Subindex: 005</td> <td></td> <td>0x60p2:01, 16</td> </tr> <tr> <td>8_{dec} = Max. Subindex: 008</td> <td>0x2 = L2 Voltage Samples</td> <td>0x60p2:02, 16</td> </tr> <tr> <td>10_{dec} = Max. Subindex: 010</td> <td></td> <td>0x3 = 4 Samples,</td> </tr> <tr> <td>16_{dec} = Max. Subindex: 016</td> <td>0x3 = L2 Current Samples</td> <td>0x60p2:01, 16</td> </tr> <tr> <td>20_{dec} = Max. Subindex: 020</td> <td></td> <td>....</td> </tr> <tr> <td>25_{dec} = Max. Subindex: 025</td> <td>0x4 = L3 Voltage Samples</td> <td>0x60p2:04, 16</td> </tr> <tr> <td>32_{dec} = Max. Subindex: 032</td> <td></td> <td>0x4 = 5 Samples,....</td> </tr> <tr> <td>40_{dec} = Max. Subindex: 040</td> <td>0x5 = L3 Current Samples</td> <td>0x5 = 8 Samples,....</td> </tr> <tr> <td>50_{dec} = Max. Subindex: 050</td> <td></td> <td>0x6 = 10 Samples,....</td> </tr> <tr> <td>64_{dec} = Max. Subindex: 064</td> <td></td> <td>0x7 = 16 Samples,....</td> </tr> <tr> <td>80_{dec} = Max. Subindex: 080</td> <td></td> <td>0x8 = 20 Samples,....</td> </tr> <tr> <td>100_{dec} = Max. Subindex: 100</td> <td></td> <td>0x9 = 25 Samples,....</td> </tr> <tr> <td></td> <td></td> <td>0xA = 32 Samples,....</td> </tr> <tr> <td></td> <td></td> <td>0xB = 40 Samples,....</td> </tr> <tr> <td></td> <td></td> <td>0xC = 50 Samples,....</td> </tr> <tr> <td></td> <td></td> <td>0xD = 64 Samples,....</td> </tr> <tr> <td></td> <td></td> <td>0xE = 80 Samples,....</td> </tr> <tr> <td></td> <td></td> <td>0xF = 100 Samples,</td> </tr> <tr> <td></td> <td></td> <td>0x60p2:01, 16</td> </tr> <tr> <td></td> <td></td> <td>....</td> </tr> <tr> <td></td> <td></td> <td>0x60p2:64, 16</td> </tr> </tbody> </table>	n	p	q	1 _{dec} = Max. Subindex: 001	0x0 = L1 Voltage Samples	0x1 = 1 Sample	2 _{dec} = Max. Subindex: 002		0x60p2:01, 16	4 _{dec} = Max. Subindex: 004	0x1 = L1 Current Samples	0x2 = 2 Samples,	5 _{dec} = Max. Subindex: 005		0x60p2:01, 16	8 _{dec} = Max. Subindex: 008	0x2 = L2 Voltage Samples	0x60p2:02, 16	10 _{dec} = Max. Subindex: 010		0x3 = 4 Samples,	16 _{dec} = Max. Subindex: 016	0x3 = L2 Current Samples	0x60p2:01, 16	20 _{dec} = Max. Subindex: 020		25 _{dec} = Max. Subindex: 025	0x4 = L3 Voltage Samples	0x60p2:04, 16	32 _{dec} = Max. Subindex: 032		0x4 = 5 Samples,....	40 _{dec} = Max. Subindex: 040	0x5 = L3 Current Samples	0x5 = 8 Samples,....	50 _{dec} = Max. Subindex: 050		0x6 = 10 Samples,....	64 _{dec} = Max. Subindex: 064		0x7 = 16 Samples,....	80 _{dec} = Max. Subindex: 080		0x8 = 20 Samples,....	100 _{dec} = Max. Subindex: 100		0x9 = 25 Samples,....			0xA = 32 Samples,....			0xB = 40 Samples,....			0xC = 50 Samples,....			0xD = 64 Samples,....			0xE = 80 Samples,....			0xF = 100 Samples,			0x60p2:01, 16					0x60p2:64, 16	UINT8	RO	> n <
n	p	q																																																																														
1 _{dec} = Max. Subindex: 001	0x0 = L1 Voltage Samples	0x1 = 1 Sample																																																																														
2 _{dec} = Max. Subindex: 002		0x60p2:01, 16																																																																														
4 _{dec} = Max. Subindex: 004	0x1 = L1 Current Samples	0x2 = 2 Samples,																																																																														
5 _{dec} = Max. Subindex: 005		0x60p2:01, 16																																																																														
8 _{dec} = Max. Subindex: 008	0x2 = L2 Voltage Samples	0x60p2:02, 16																																																																														
10 _{dec} = Max. Subindex: 010		0x3 = 4 Samples,																																																																														
16 _{dec} = Max. Subindex: 016	0x3 = L2 Current Samples	0x60p2:01, 16																																																																														
20 _{dec} = Max. Subindex: 020																																																																															
25 _{dec} = Max. Subindex: 025	0x4 = L3 Voltage Samples	0x60p2:04, 16																																																																														
32 _{dec} = Max. Subindex: 032		0x4 = 5 Samples,....																																																																														
40 _{dec} = Max. Subindex: 040	0x5 = L3 Current Samples	0x5 = 8 Samples,....																																																																														
50 _{dec} = Max. Subindex: 050		0x6 = 10 Samples,....																																																																														
64 _{dec} = Max. Subindex: 064		0x7 = 16 Samples,....																																																																														
80 _{dec} = Max. Subindex: 080		0x8 = 20 Samples,....																																																																														
100 _{dec} = Max. Subindex: 100		0x9 = 25 Samples,....																																																																														
		0xA = 32 Samples,....																																																																														
		0xB = 40 Samples,....																																																																														
		0xC = 50 Samples,....																																																																														
		0xD = 64 Samples,....																																																																														
		0xE = 80 Samples,....																																																																														
		0xF = 100 Samples,																																																																														
		0x60p2:01, 16																																																																														
																																																																															
		0x60p2:64, 16																																																																														
1Apq:hh (for 01 _{hex} ≤ hh ≤ 64 _{hex})	Subindex n	Voltage Samples or Current Samples	INT16	RO	-																																																																											

Index 1A60 Analog Input TxPDO-Map Timestamp

Index (hex)	Name	Meaning	Data type	Flags	Default
1A60:0	AI Timestamp Next Sync1 Time	Max. Subindex	UINT8	RO	> 1 <
1A60:01	Subindex 001	1. PDO Mapping entry (object 0x6060 (AI Inputs), entry 0x01 (Next Sync1 Time))	UINT64	RO	0x6060:01, 64

Index 1A61 Analog Input TxPDO-Map Sample Counter

Index (hex)	Name	Meaning	Data type	Flags	Default
1A60:0	AI Timestamp Sample Counter	Max. Subindex	UINT8	RO	> 1 <
1A61:01	Subindex 001	1. PDO Mapping entry (object 0x6061 (AI Inputs), entry 0x01 (SampleCount))	UINT16	RO	0x6061:01, 16

Index 1C00 0 Sync manager type

Index (hex)	Name	Meaning	Data type	Flags	Default
1C00:0	Sync manager type	Using the sync managers	UINT8	RO	> 4 <
1C00:01	SubIndex 001	Sync-Manager Type Channel 1: Mailbox Write	UINT8	RO	0x01 (1 _{dec})
1C00:02	SubIndex 002	Sync-Manager Type Channel 2: Mailbox Read	UINT8	RO	0x02 (2 _{dec})
1C00:03	SubIndex 003	Sync-Manager Type Channel 3: Process Data Write (Outputs)	UINT8	RO	0x03 (3 _{dec})
1C00:04	SubIndex 004	Sync-Manager Type Channel 4: Process Data Read (Inputs)	UINT8	RO	0x04 (4 _{dec})

Index 1C12 RxPDO assign

Index (hex)	Name	Meaning	Data type	Flags	Default
1C12:0	RxPDO assign	PDO Assign Outputs	UINT8	RW	> 0 <

Index 1C13 TxPDO assign

For operation on masters other than TwinCAT it must be ensured that the channels are entered in the PDO assignment ("TxPDO assign", object 0x1C13) successively.

Index (hex)	Name	Meaning	Data type	Flags	Default
1C13:0	TxPDO assign	PDO Assign Inputs	UINT8	RW	> 4 <
1C13:01	SubIndex 001	1. allocated TxPDO (contains the index of the associated TxPDO mapping object)	UINT16	RW	0x1A00 (6656 _{dec})
1C13:02	SubIndex 002	2. allocated TxPDO (contains the index of the associated TxPDO mapping object)	UINT16	RW	0x1A06 (6662 _{dec})
1C13:03	SubIndex 003	3. allocated TxPDO (contains the index of the associated TxPDO mapping object)	UINT16	RW	0x1A10 (6672 _{dec})
1C13:04	SubIndex 004	4. allocated TxPDO (contains the index of the associated TxPDO mapping object)	UINT16	RW	0x1A16 (6678 _{dec})
1C13:05	SubIndex 005	5. allocated TxPDO (contains the index of the associated TxPDO mapping object)	UINT16	RW	0x1A20 (6688 _{dec})
1C13:06	SubIndex 006	6. allocated TxPDO (contains the index of the associated TxPDO mapping object)	UINT16	RW	0x1A26 (6694 _{dec})
1C13:07	SubIndex 007	7. allocated TxPDO (contains the index of the associated TxPDO mapping object)	UINT16	RW	0x1A30 (6704 _{dec})
1C13:08	SubIndex 008	8. allocated TxPDO (contains the index of the associated TxPDO mapping object)	UINT16	RW	0x1A36 (6710 _{dec})
1C13:09	SubIndex 009	9. allocated TxPDO (contains the index of the associated TxPDO mapping object)	UINT16	RW	0x1A40 (6720 _{dec})
1C13:0A	SubIndex 010	10. allocated TxPDO (contains the index of the associated TxPDO mapping object)	UINT16	RW	0x1A46 (6726 _{dec})
1C13:0B	SubIndex 011	11. allocated TxPDO (contains the index of the associated TxPDO mapping object)	UINT16	RW	0x1A50 (6736 _{dec})
1C13:0C	SubIndex 012	12. allocated TxPDO (contains the index of the associated TxPDO mapping object)	UINT16	RW	0x1A56 (6742 _{dec})
1C13:0D	SubIndex 013	13. allocated TxPDO (contains the index of the associated TxPDO mapping object)	UINT16	RW	0x1A60 (6752 _{dec})
1C13:0E	SubIndex 014	14. allocated TxPDO (contains the index of the associated TxPDO mapping object)	UINT16	RW	0x1A61 (6753 _{dec})

Index 1C33 SM input parameter

Index (hex)	Name	Meaning	Data type	Flags	Default
1C33:0	SM input parameter	Synchronization parameters for the inputs	UINT8	RO	> 32 <
1C33:01	Sync mode	Current synchronization mode: <ul style="list-style-type: none"> • Bit 0 = 0: Free Run • Bit 0 = 1: Synchron with SM 2 Event • Bit 0-1 = 11: DC with SYNC1 event • Bit 15 = 1: Fast Mode 	UINT16	RW	0x0002 (2 _{dec})
1C33:02	Cycle time	Cycle time (in ns): <ul style="list-style-type: none"> • Free Run: Cycle time of the local timer • Synchronous with SM 2 event: Master cycle time • DC-Mode: SYNC0/SYNC1 Cycle Time 	UINT32	RW	0x003D0900 (4000000 _{dec})
1C33:03	Shift time	Time between SYNC0 event and reading of the inputs (in ns, only DC mode)	UINT32	RO	0x00000000 (0 _{dec})
1C33:04	Sync modes supported	Supported synchronization modes: <ul style="list-style-type: none"> • Bit 0 = 1: Free Run • Bit 1 = 1: Synchron with SM 2 Event (Outputs available) • Bit 2 = 1: DC-Mode (SYNC0) • Bit 3 = 1: DC-Mode (SYNC1) • Bit 12 = 1: Legacy Synchron • Bit 13 = 1: SM event • Bit 14 = 1: dynamic times (measure by writing 0x1C33:08 [101]) • Bit 15 = 1: Fast Mode 	UINT16	RO	0x0806 (2054 _{dec})
1C33:05	Minimum cycle time	Minimum cycle time (in ns)	UINT32	RO	0x000186A0 (100000 _{dec})
1C33:06	Calc and copy time	Time between reading of the inputs and availability of the inputs for the master (in ns, only DC mode)	UINT32	RO	0x00000000 (0 _{dec})
1C33:08	Command	With this entry the real required process data provision time can be measured. <ul style="list-style-type: none"> • 0: Measurement of the local cycle time is stopped • 1: Measurement of the local cycle time is started <p>The entries 0x1C33:03 [101], 0x1C33:06 [101], 0x1C33:09 [101] are updated with the maximum measured values. For a subsequent measurement the measured values are reset</p>	UINT16	RW	0x0000 (0 _{dec})
1C33:09	Maximum Delay time	Time between SYNC1 event and reading of the inputs (in ns, only DC mode)	UINT32	RO	0x00000000 (0 _{dec})
1C33:0B	SM event missed counter	Number of missed SM events in OPERATIONAL (DC mode only)	UINT16	RO	0x0000 (0 _{dec})
1C33:0C	Cycle exceeded counter	Number of occasions the cycle time was exceeded in OPERATIONAL (cycle was not completed in time or the next cycle began too early)	UINT16	RO	0x0000 (0 _{dec})
1C33:0D	Shift too short counter	Number of occasions that the interval between SYNC0 and SYNC1 event was too short (DC mode only)	UINT16	RO	0x0000 (0 _{dec})
1C33:20	Sync error	The synchronization was not correct in the last cycle (outputs were output too late; DC mode only)	BOOLEAN	RO	FALSE

Index F000 Modular device profile

Index (hex)	Name	Meaning	Data type	Flags	Default
F000:0	Modular device profile	General information for the modular device profile	UINT8	RO	> 2 <
F000:01	Module index distance	Index distance of the objects of the individual channels	UINT16	RO	0x0010 (16 _{dec})
F000:02	Maximum number of modules	Number of channels	UINT16	RO	0x0007 (7 _{dec})

Index F008 Code word

Index (hex)	Name	Meaning	Data type	Flags	Default
F008:0	Code word	reserved	UINT32	RW	0x00000000 (0 _{dec})



Index F010 Module list

Index (hex)	Name	Meaning	Data type	Flags	Default
F010:0	Module list	Maximum subindex	UINT8	RW	> 7 <
F010:01	SubIndex 001	Analog input profile (300)	UINT32	RW	0x0000012C (300 _{dec})
F010:02	SubIndex 002	Analog input profile (300)	UINT32	RW	0x0000012C (300 _{dec})
F010:03	SubIndex 003	Analog input profile (300)	UINT32	RW	0x0000012C (300 _{dec})
F010:04	SubIndex 004	Analog input profile (300)	UINT32	RW	0x0000012C (300 _{dec})
F010:05	SubIndex 005	Analog input profile (300)	UINT32	RW	0x0000012C (300 _{dec})
F010:06	SubIndex 006	Analog input profile (300)	UINT32	RW	0x0000012C (300 _{dec})
F010:07	SubIndex 007	Analog input profile (300)	UINT32	RW	0x0000012C (300 _{dec})

6.7 Application examples

Power measurement at a machine

- The voltage is measured via connections L1, L2, L3 and N.
- The current is measured via three current transformers [► 123] and the connections I_{L1} , I_{L2} , I_{L3} and I_N (star point of the current transformers).

 WARNING	<p>WARNING: Risk of electric shock!</p> <p>Bring the Bus Terminals system into a safe, de-energized state before starting mounting, disassembly or wiring of the Bus Terminals.</p>
 Attention	<p>Attention! Risk of device damage!</p> <p>Avoid confusing the current and voltage circuit during connection, since the direct connection of mains voltage to the terminal points for the current transformers (typical input resistance 220 mΩ) would destroy the power measurement terminal!</p>

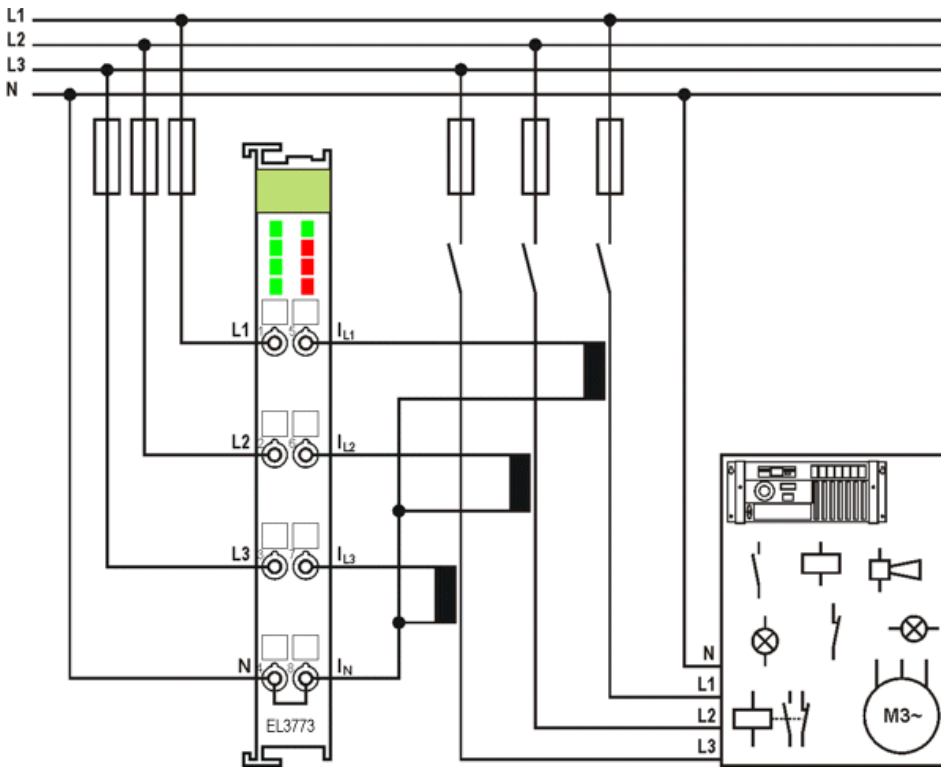

Fig. 111: Power measurement at a machine

	<p>Negative power values</p>
<p>Note</p>	<p>If negative power values are measured on a circuit, please check whether the associated current transformer circuit is connected correctly.</p>
	<p>Current measurement</p>
<p>Note</p>	<p>A current measurement requires a voltage source to be connected. A current measurement is not possible without voltage source.</p>

Power measurement on motor with 2 current transformers

- The voltage is measured via the connections L1, L2 and L3.
- The current is measured with two current transformers [▶ 123] via the connections I_{L1} and I_{L2}.
- The sum of all currents in the 3-phase mains network is 0. The value in circuit I_{L3} can be obtained accordingly by wiring the EL3773.

	<p>WARNING: Risk of electric shock!</p>
<p>WARNING</p>	<p>If you do not connect terminal point N with the neutral conductor of your mains supply, you have to earth terminal point N, in order to avoid dangerous overvoltages in the event of a fault with a current transformer!</p>
	<p>Attention! Risk of device damage!</p>
<p>Attention</p>	<p>Avoid confusing the current and voltage circuit during connection, since the direct connection of mains voltage to the terminal points for the current transformers (typical input resistance 220 mΩ) would destroy the power measurement terminal!</p>

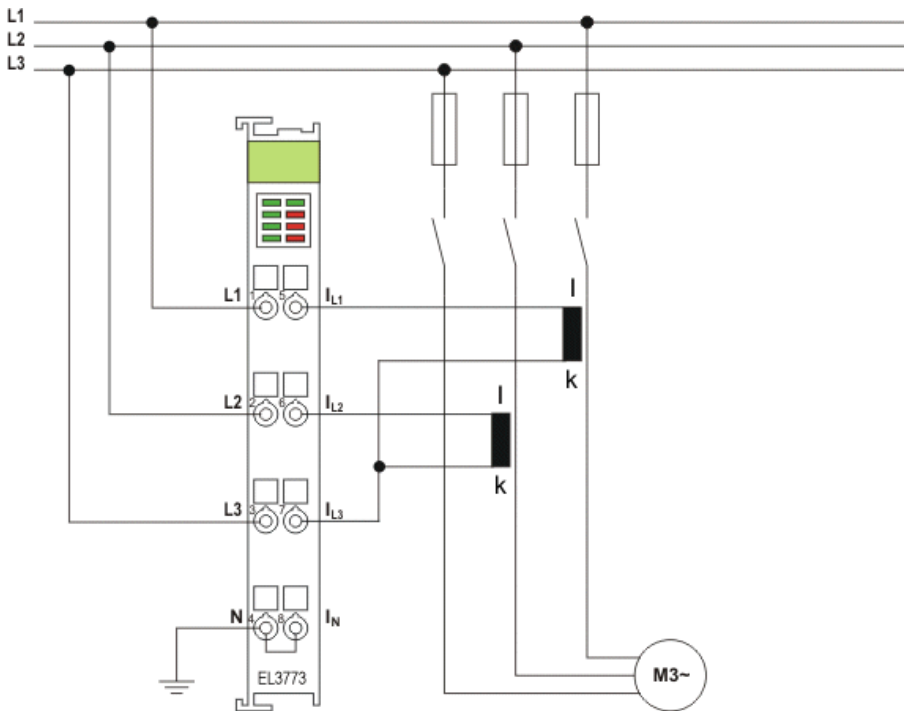

Fig. 112: Power measurement with 2 current transformers on a motor

In the circuit shown above (Fig. *Power measurement with 2 current transformers on a motor*), ensure that the three-phase system is either earth-free or has an earthed star point. Alternatively a transformer can be included in a Yy0 circuit.

Power measurement in a single-phase mains network with ohmic consumers

- The voltage is measured via connections L1, L2, L3 and N.
- The current is measured via three current transformers [▶ 123] and the connections I_{L1} , I_{L2} , I_{L3} and I_N (star point of the current transformers).



WARNING

WARNING: Risk of electric shock!

Bring the Bus Terminals system into a safe, de-energized state before starting mounting, disassembly or wiring of the Bus Terminals.



Attention

Attention! Risk of device damage!

Avoid confusing the current and voltage circuit during connection, since the direct connection of mains voltage to the terminal points for the current transformers (typical input resistance 220 mΩ) would destroy the power measurement terminal!

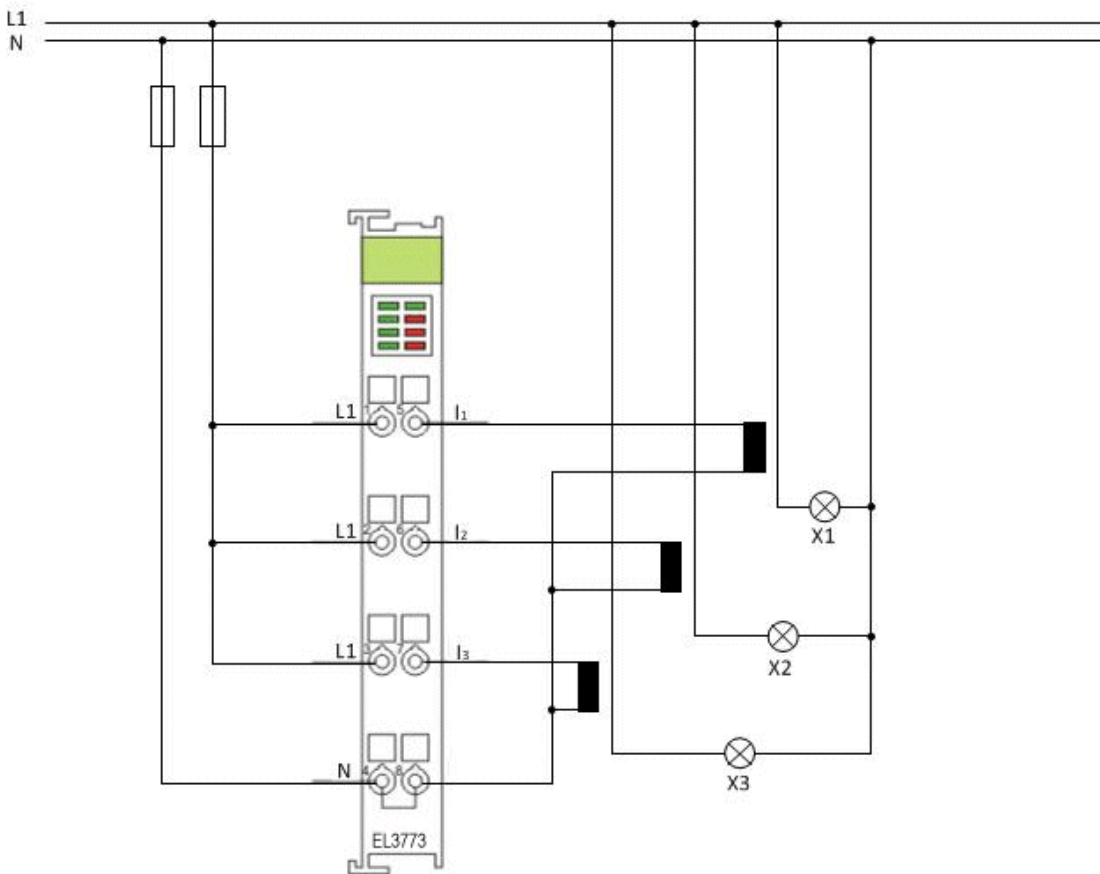

Fig. 113: Power measurement at ohmic consumers

6.8 Oversampling terminals and TwinCAT Scope

Generally input data of a terminal could be achieved by the scope either directly (via the activated ADS server) or by creation of a PLC variable which is linked to the PDO of a terminal for recording them. Both procedures will be explained for TwinCAT 3 (TC3) at first and for TwinCAT 2 (TC2) respectively.

Oversampling means that an analog or digital input device supplies not only one measured value for each process data cycle/EtherCAT cycle (duration T), but several, which are determined at a constant interval $t < T$. The ratio T/t is the oversampling factor n .

A channel thus offers not only one PDO for linking in the process data, as in the example here with the EL3102, but n PDOs as in the case of the EL3702 and other oversampling terminals.

The definition of “oversampling” by the Beckhoff’s point of view shouldn’t be mixed up with the oversampling process of a deltaSigma ADC:

- **deltaSigma ADC:** the frequency used by the ADC to sample the analogue signal is faster than a multiple times than the frequency of the provided digital data (typically in kHz range). This is called oversampling resulting by the functional principle of this converter type and serve amongst others for anti-aliasing.
- **Beckhoff:** the device/ the terminal read of the used ADC (could be a deltaSigma ADC also) digital sample data n -times more than the PLC/ bus cycle time is set and transfers every sample to the control – bundled as an oversampling PDO package.

For example these both procedures are arranged sequentially by their technical implementation within the EL3751 and can also be present simultaneously.

EL3102

Name	Type	Size
↕↑ Status	Status_4099	2.0
↕↑ Value	INT	2.0
↕↑ Status	Status_4099	2.0
↕↑ Value	INT	2.0

EL3702

Name	Type	Size
↕↑ Ch1 CycleCount	UINT	2.0
↕↑ Ch1 Value	INT	2.0
↕↑ Ch1 Value	INT	2.0
↕↑ Ch1 Value	INT	2.0
↕↑ Ch1 Value	INT	2.0
↕↑ Ch1 Value	INT	2.0
↕↑ Ch1 Value	INT	2.0
↕↑ Ch1 Value	INT	2.0
↕↑ Ch1 Value	INT	2.0
↕↑ Ch1 Value	INT	2.0
↕↑ Ch1 Value	INT	2.0
↕↑ Ch2 CycleCount	UINT	2.0
↕↑ Ch2 Value	INT	2.0
↕↑ Ch2 Value	INT	2.0
↕↑ Ch2 Value	INT	2.0
↕↑ Ch2 Value	INT	2.0
↕↑ Ch2 Value	INT	2.0
↕↑ Ch2 Value	INT	2.0
↕↑ Ch2 Value	INT	2.0
↕↑ Ch2 Value	INT	2.0
↕↑ Ch2 Value	INT	2.0
↕↑ Ch2 Value	INT	2.0

Fig. 114: Oversampling PDO of the EL37xx series and in the comparison with EL31xx

Accordingly the Scope2 (TC2) or ScopeView (TC3) can read in and display several PDOs per cycle in correct time.

6.8.1 TwinCAT 3 procedure

From TwinCAT 3.1 build 4012 and using the revision as below specified in the configuration, the integrated ScopeView recognizes in its variable browser that the oversampling data is an array package and activates ForceOversampling automatically. The array as a whole must be selected using *AddSymbol* (see description in the next section). The extended PDO name provides the basis for this. Since a specific revision of the respective terminal ScopeView is able to detect the array type of a set of variables autonomous.

Terminal	Revision
EL4732	all
EL4712	all
EL3783	EL3783-0000-0017
EL3773	EL3773-0000-0019
EL3751	all
EL3742	all
EL3702	all
EL3632	all
EL2262	all
EL1262-0050	all
EL1262	all

Recording a PLC Variable with the TwinCAT 3 – ScopeView

By a precondition of an already created TwinCAT 3 – project and a connected PLC with an oversampling able terminal within the configuration it will be illustrated how an oversampling variable can be represented by the Scope (as a standard part of the TwinCAT 3 environment). This will be explained by means of several steps based on an example project “SCOPE_with_Oversampling” as a standard PLC project.

Step 1: Adding a project „Scope YT“

The example project “SCOPE_with_Oversampling” have to be added a TwinCAT Measurement – project “Scope YT project” (C) by right click (A) and selection (B) “Add” → “New Project..”. Then “Scope for OS” will be entered as name. The new project just appears within the solution explorer (D).

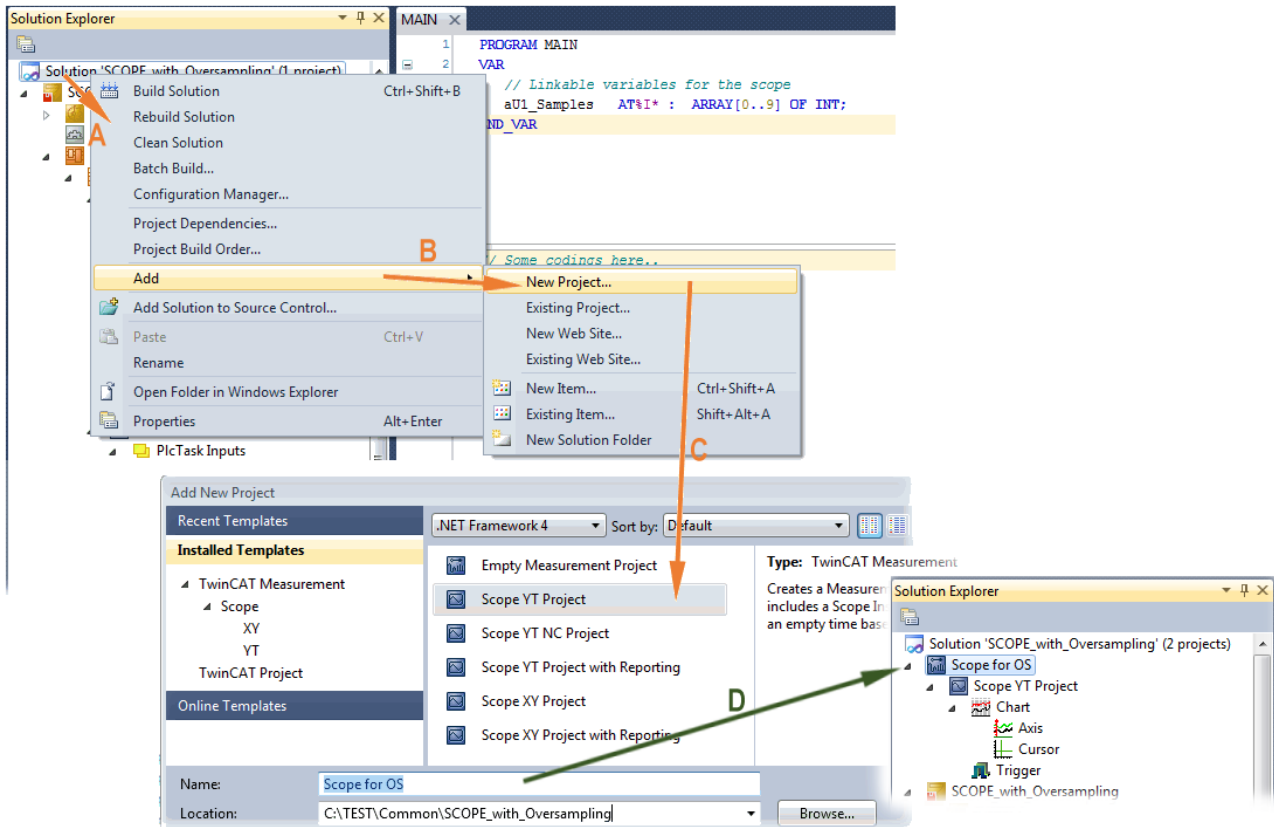

Fig. 115: Adding a Scope project into an already existing project

Step 2a: Creation of a PLC variable within a POU

Within the TwinCAT 3 development environment an input variable as an array with respective amount than is given by the oversampling factor have to be defined at first how it's illustrated in an example for the POU “MAIN” and an oversampling factor 10 with structured text (ST) as follows:

```
PROGRAM MAIN
VAR
  aU1_Samples AT%I* : ARRAY[0..9] OF INT;
END_VAR
```

The identification “AT%I*” stands for swapping out this array variable to link it with the process data objects (PDOs) of a terminal later. Notice that at least the number of elements have to be the same as the oversampling factor so that the indices can be set from 0 to 9 also. As soon as the compiling procedure was started and ended successful (in doing so no program code may be present) the array appears into the solution explorer of the TwinCAT 3 development environment within the section PLC under “..Instance”.

The following illustration shows extracts of the solution explorer on the right. As an example that linking of an array variable to a set of oversampling process data is represented herewith:

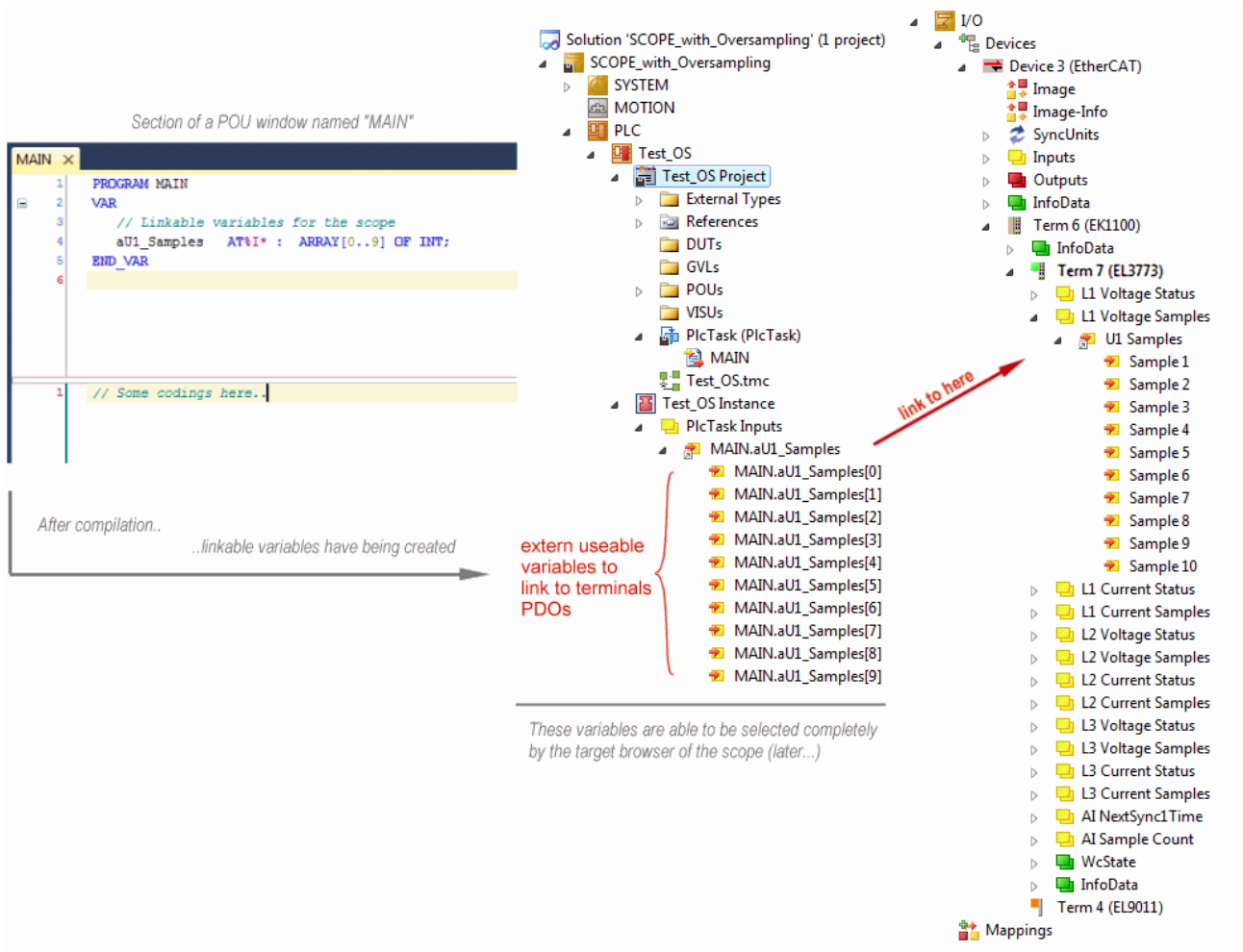

Fig. 116: Representation of a created PLC array variable („aU1_Samples“) to link with oversampling PDOs of EL3773

Step 2b: Creation of a PLC variable via a free task

When a POU is not needed onto the particular system, a referenced variable could be applied via a free task also. If a free task is not existing still yet, it can be created by a right-click to “Task” of the project within SYSTEM with “Add New Item...”.

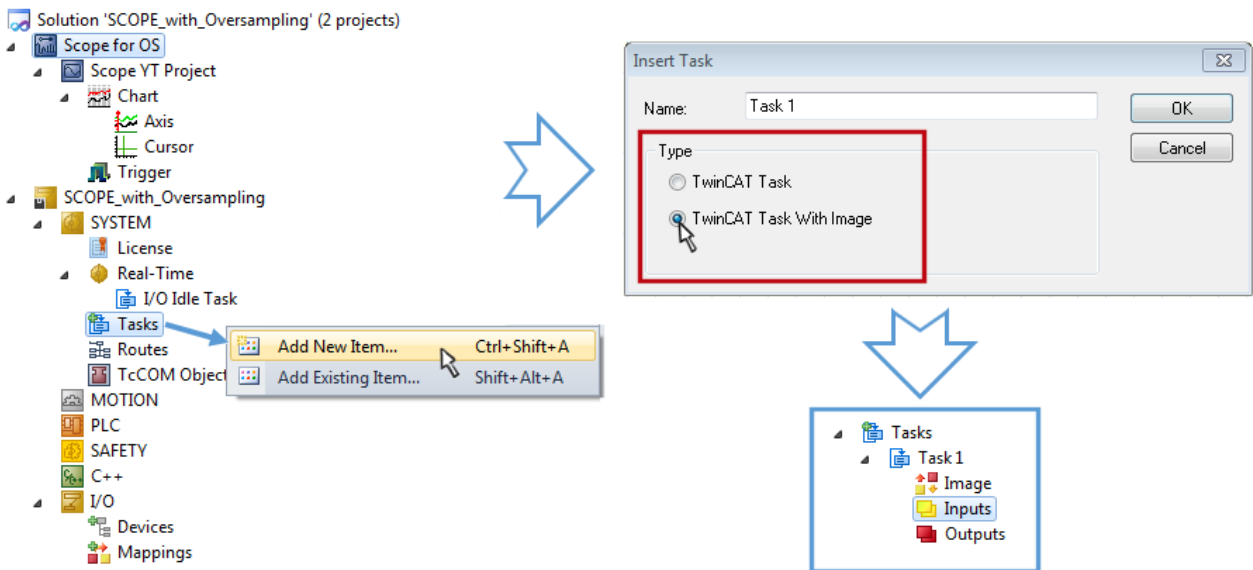

Fig. 117: Insertion of a free task

The Task have to be inserted as “TwinCAT Task With Image” and also creates an “Inputs” and “Outputs” folder therefore. The properties of the new (or as the case may be already existing) task must have activated the attribute “Create symbols” to make them selectable by the “Target Browser” of the Scope later on. The task cycle time have to be changed if so. Then, with 10 x Oversampling 1 ms at 100 µs base time, resulting 10 ticks will be set by the usage of the EL3751 for example:

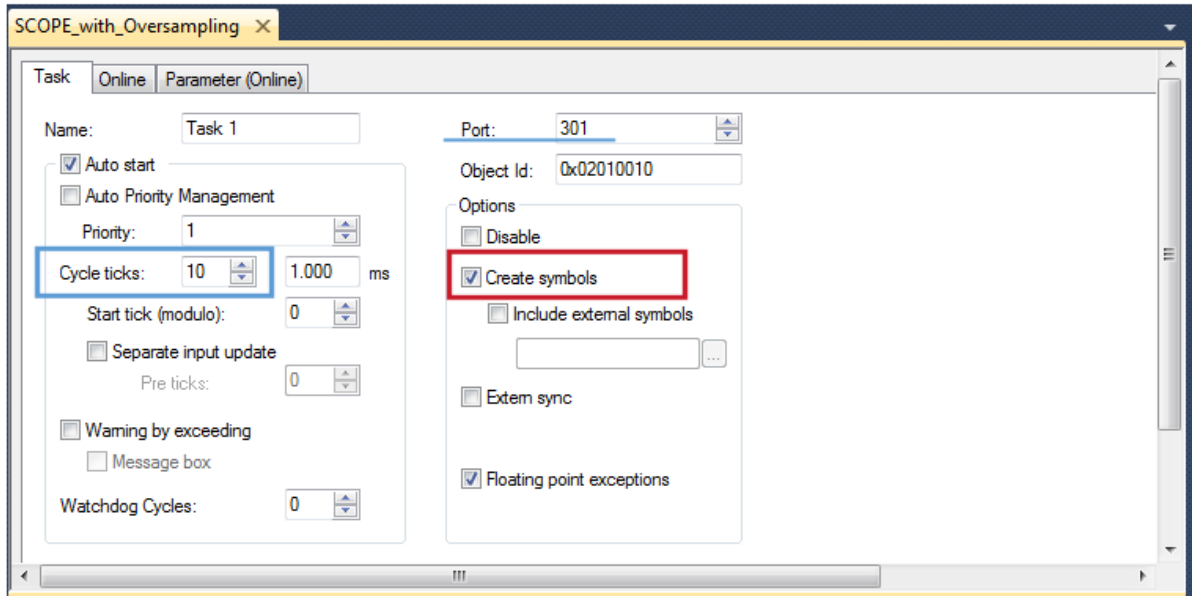

Fig. 118: Task property "Create symbols" must be activated

There's a default value given for the Port number (301) that should be changed, if necessary. This number have to make acquainted for the Scope, if applicable, later on. By a right click on “Inputs” that oversampling based variable can now be appended with the fitting datatype of an array. „ARRAY [0..9] OF DINT“ referred to as „Var 1“ in this case:

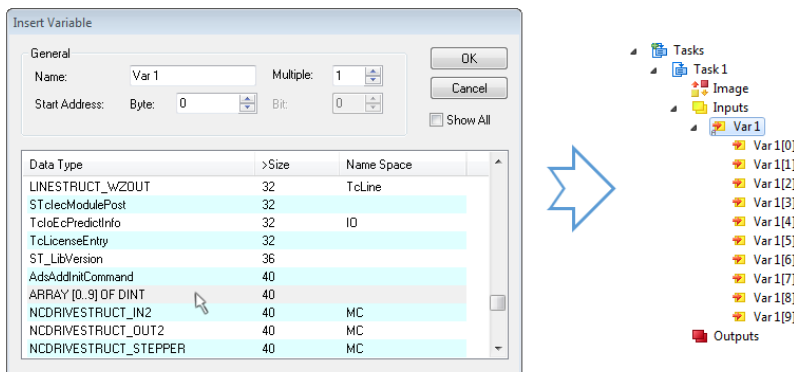

Fig. 119: Insertion of variable "Var 1" fitting to the oversampling (-factor)

Step 3: Linking an array variable with an oversampling PDO

By right click on “MAIN.aUI_Samples” (according to the last preceding paragraph Step 2a) or rather “Var 1” (according to the last preceding paragraph Step 2b) within the Solution Explorer a window opens to select the process data:

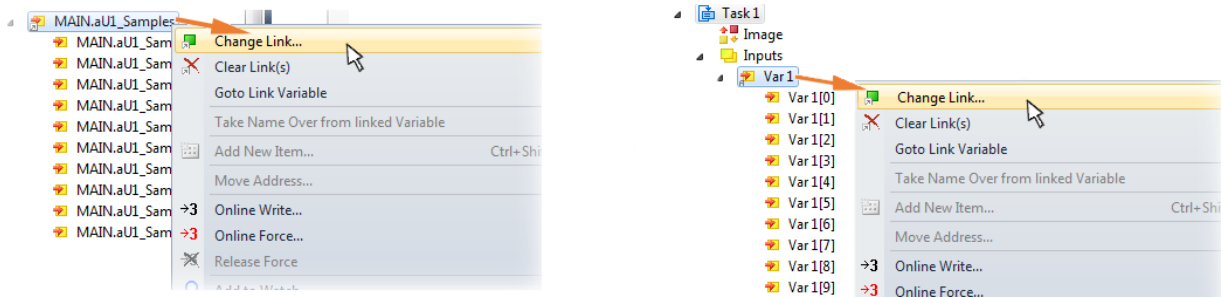

Fig. 120: Set up the link of the PLC array variable (left: for the last preceding paragraph Step 2a, right: for the last preceding paragraph Step 2b)

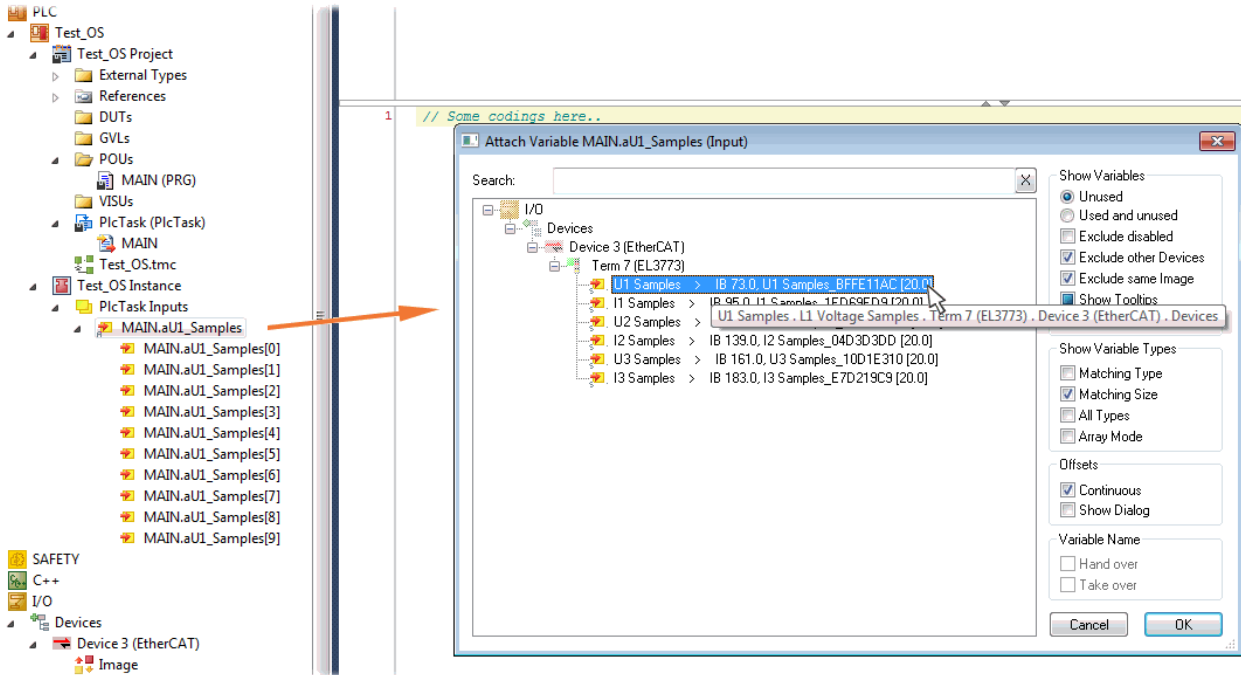



Fig. 121: Select the EL3773 PDO "L1 Voltage Samples" to create a link to the PLC array variable „aUI_Samples“

The selection of PDO "U1 Samples" of the EL3773 for "MAIN.aUI_Samples" based by the last preceding paragraph Step 2a as illustrated above have to be done in the same way for "Var 1" accordingly.

Step 4: Selection of the PLC array variable for the Y-axis of the scope

Now the configuration will be activated () and logged in the PLC (), so the array variable will be visible for the target browser of the scope for being selected.

Thereby the drop down menu will be opened by right clicking on "Axis" (A) for selection of the scope features (B):

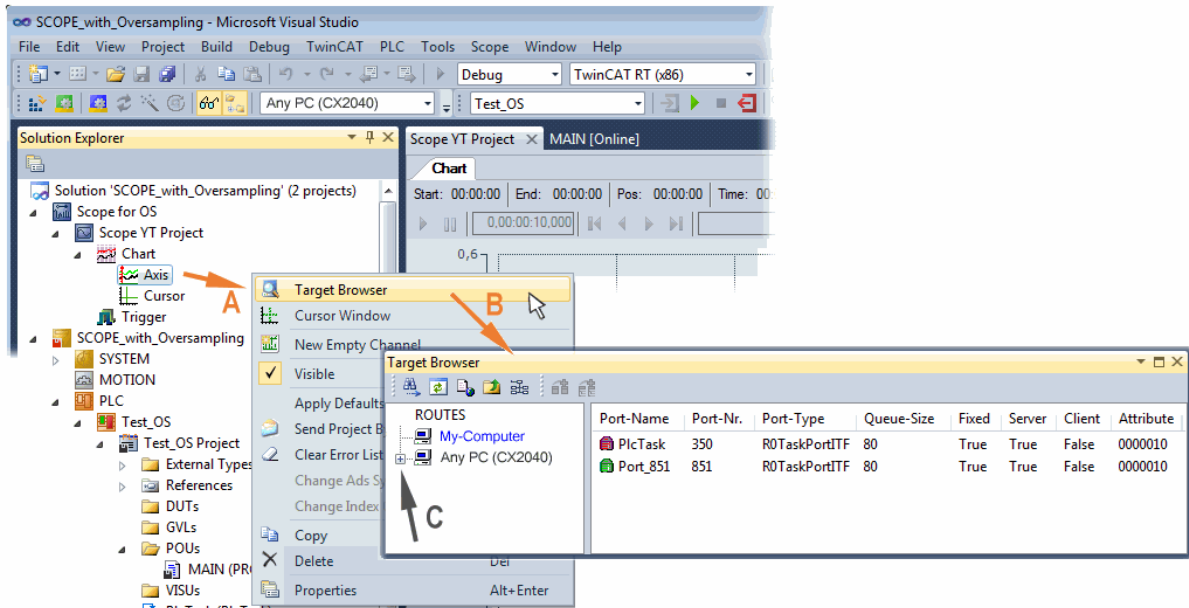

Fig. 122: Selection of the oversampling variable with the target browser

By addressing the corresponding system that represents the PLC containing the array variable (“Any PC (CX2040)”) in this case) navigation up to the variable “aUI_Samples” (C) have to be done.

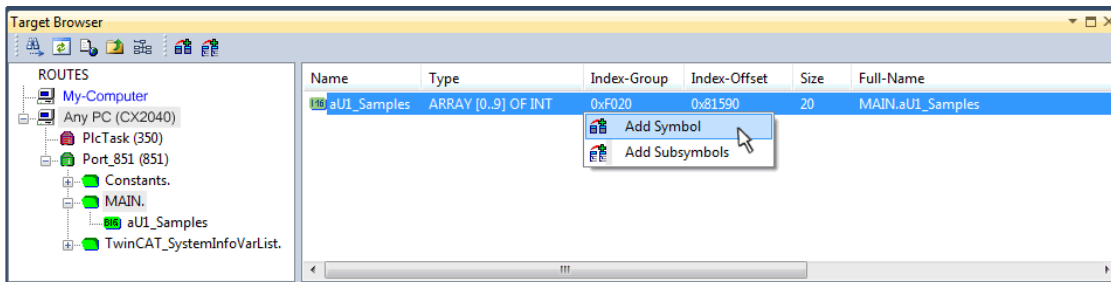

Fig. 123: Appending the variable "aUI_Samples" below "axis" within the scope project of the solution explorer

i

Note

Variable don't appears into the target browser

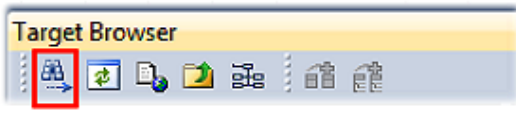

If „ROUTES“ don't offer a possibility for selection of the provided variables, the corresponding port should be declared for the target browser:

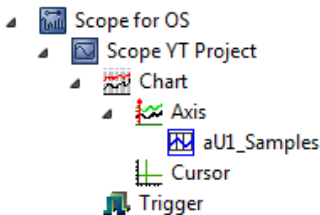

"Enable Server Ports"

Using “Add symbol” displays the variable "aUI_Samples" below “axis” within the scope project of the solution explorer directly.



Now the program start have to be done with  formally although there's no program still yet. Using "Start Recording"  the process data value of the oversampling PDO "L1 Voltage Samples" via the linked PLC array variable can be recorded time dependent now.

As an example a sine wave input measurement value (204.5 Hz) will be illustrated below:

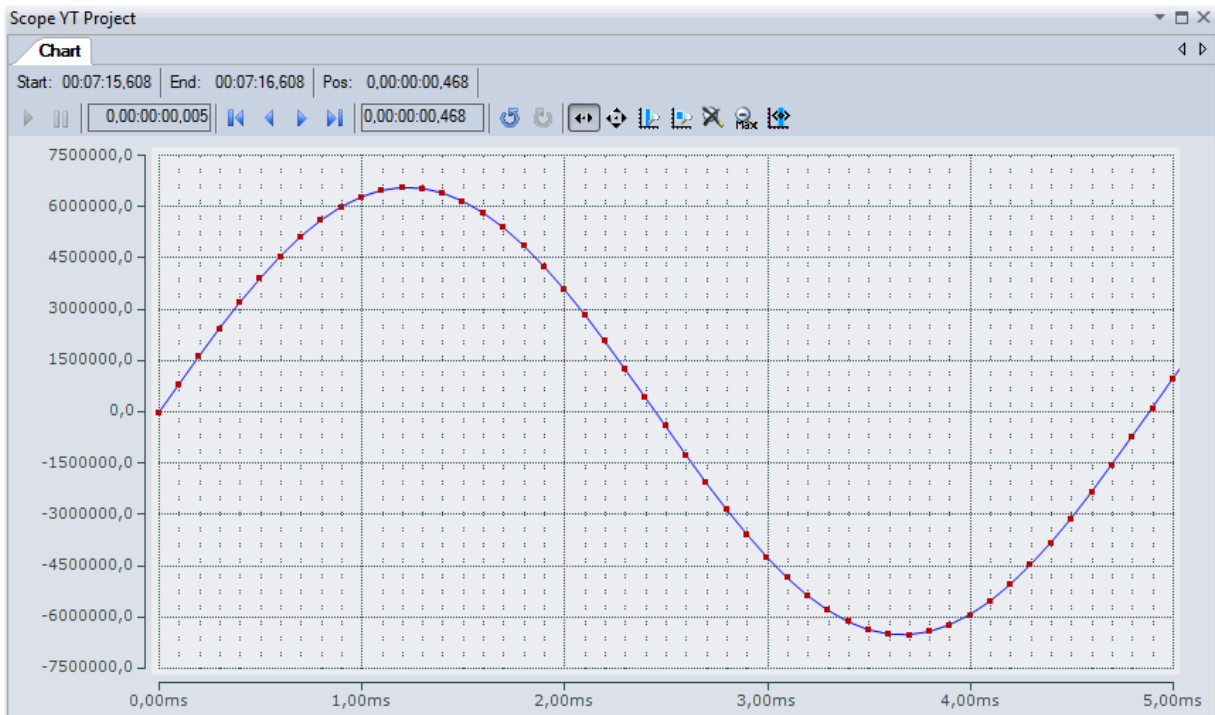



Fig. 124: Example of recording a sine signal with 10 x oversampling at 1 ms measurement cycle time

The X-axis view was fitted properly by using "Panning X"  after the recording was stopped . Following the "Chart" property "Use X-Axis SubGrid" was set to true with 10 divisions as well as the "ChannelNodeProperties" attribute "Marks" was set to "On" with the colors "Line Color" blue and "Mark Color" red. Therefore the latter indicates that 10 oversampling measurement points by the red marks.

Proceeding with / via ADS alternatively

In former TwinCAT 3 versions (or a lower revision as specified in the [table \[▶ 106\]](#) above) the oversampling PDO of the respective oversampling able terminal can be made visible for the ScopeView by activation of the ADS server.

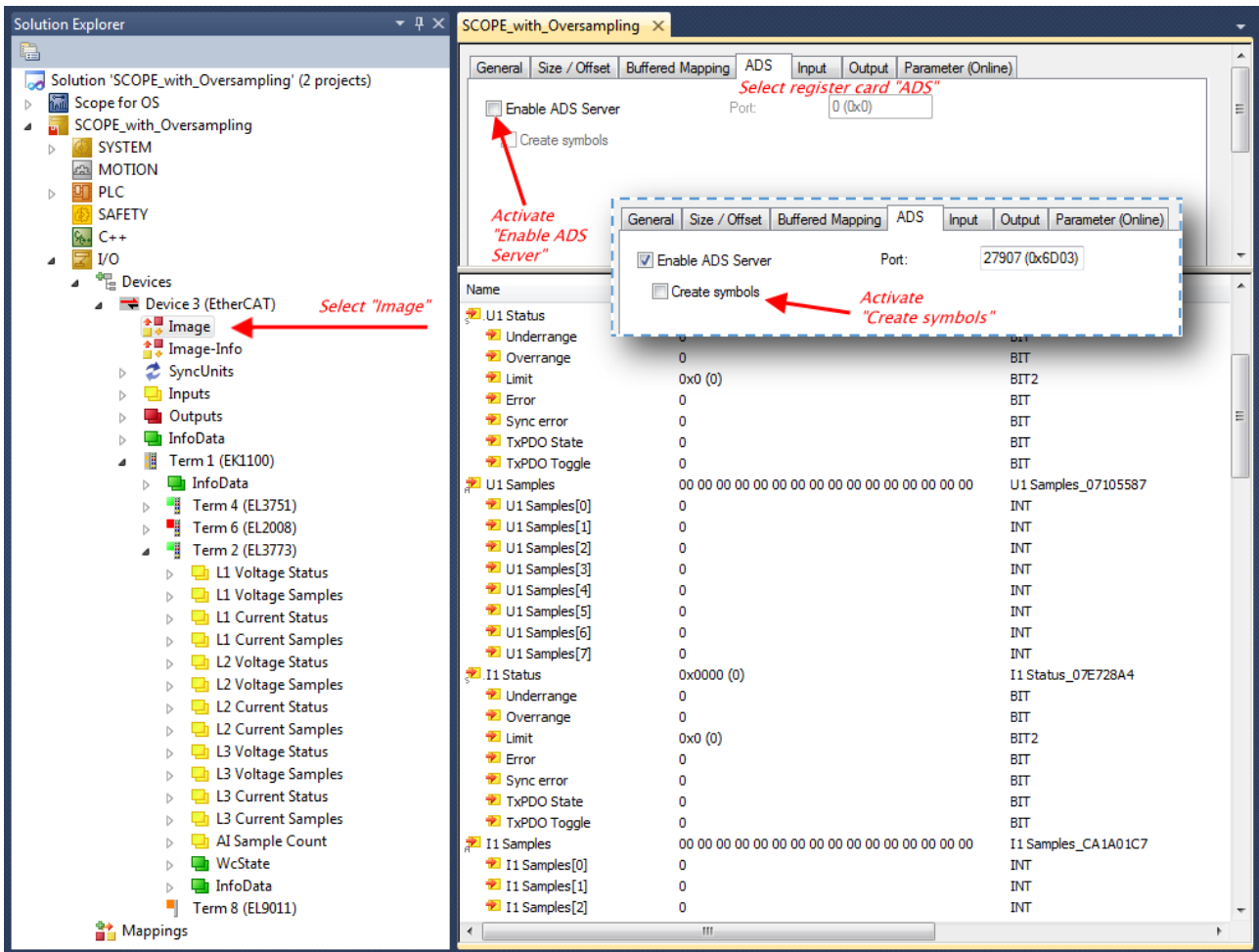

Fig. 125: Activation of the ADS server of the EtherCAT device (TwinCAT 3)

The activation of the server can be carried out by selection of “Image” within the left sided solution explorer: „I/O → Devices → Device .. (EtherCAT) → Image“.

Next the register card “ADS” have to be selected to activate each checkbox „Enable ADS Server“ and „Create symbols“ then (the port entry is done automatically).

Thereby it is possible to access process data without an embedded POU and accordingly without a linked variable:

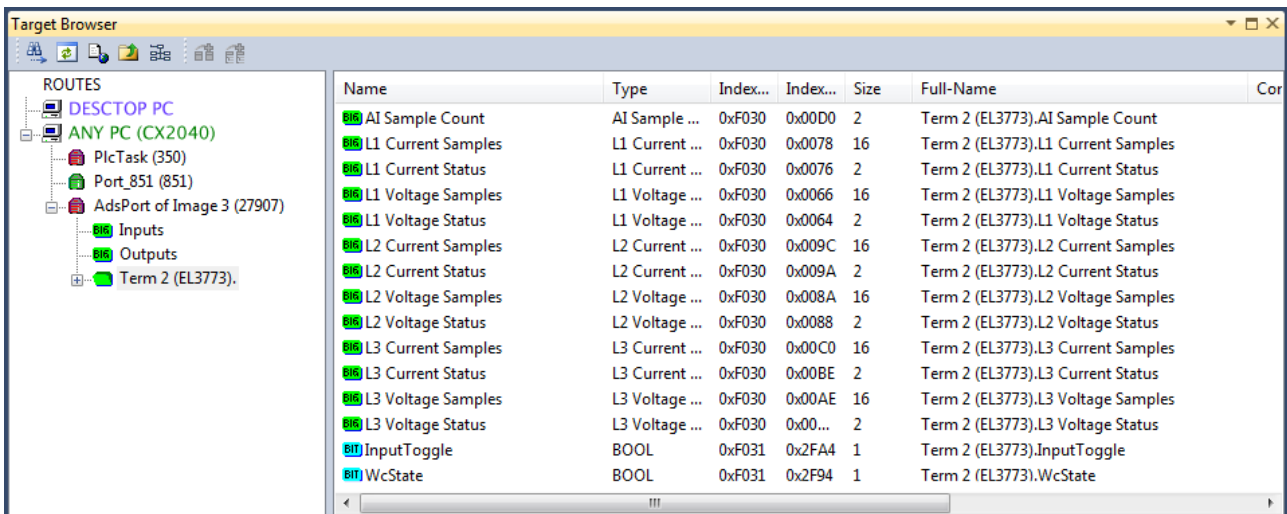

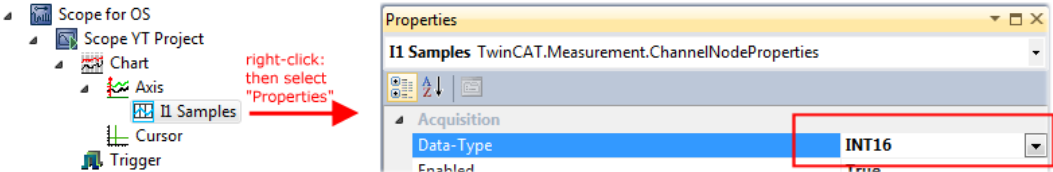

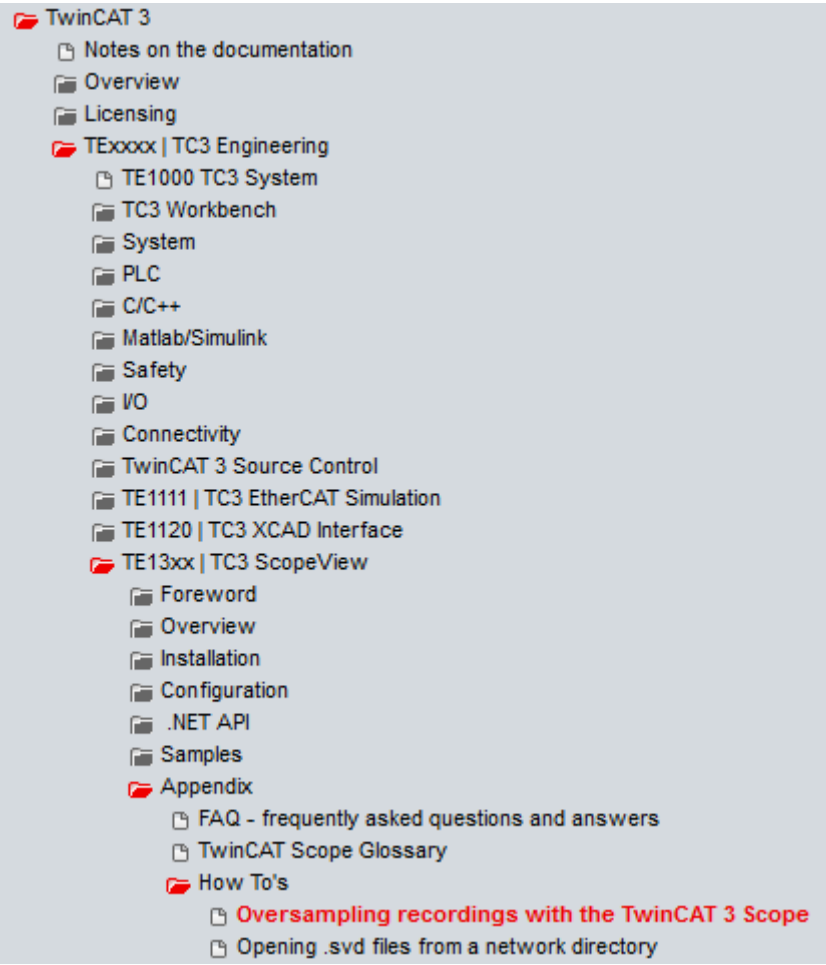



Fig. 126: Direct access to PDOs of the terminal by ScopeView

 Note	<p>Data type not valid</p> <p>It may happen that the target browser is unable to determine the data type after insertion of the oversampling PDO (according to an array variable usually). In this case it can be changed by the channel properties:</p>  <p>The screenshot shows a project tree on the left with 'I1 Samples' selected. A red arrow points to the 'Properties' window on the right. In the 'Properties' window, under the 'Acquisition' section, the 'Data-Type' dropdown menu is open and set to 'INT16'.</p>
--	--

 Note	<p>TwinCAT 3: Activate the ADS Server of an EtherCAT device</p> <p>Also see Beckhoff Information System:</p>  <p>The screenshot shows a website navigation menu for TwinCAT 3. The menu items are: Notes on the documentation, Overview, Licensing, TExxxx TC3 Engineering (expanded), TE1000 TC3 System, TC3 Workbench, System, PLC, C/C++, Matlab/Simulink, Safety, I/O, Connectivity, TwinCAT 3 Source Control, TE1111 TC3 EtherCAT Simulation, TE1120 TC3 XCAD Interface, TE13xx TC3 ScopeView (expanded), Foreword, Overview, Installation, Configuration, .NET API, Samples, Appendix (expanded), FAQ - frequently asked questions and answers, TwinCAT Scope Glossary, How To's (expanded), Oversampling recordings with the TwinCAT 3 Scope, and Opening .svd files from a network directory.</p>
--	---

6.8.2 TwinCAT 2 procedure

The TwinCAT Scope2 supports the import and display of oversampling process data such as is used by oversampling-able terminals.

 Note	<p>System requirements</p> <p>A TwinCAT Scope2 must be installed on the system. An oversampling-able terminal must be present in the configuration.</p>
--	---

The data type of the variables is also conveyed to the TwinCAT Scope2 via the ADS data. Therefore the array variable must be created

- in the PLC, see [step 1a](#) [► 115]

- or directly in the System Manager if only one free task is present, see [step 1b](#) [▶ 115]

The same settings are to be made in the Scope2 for both cases, see [step 2](#) [▶ 117]

Recording of a PLC variable with the TwinCAT 2 – Scope2

Step 1a: TwinCAT 2 PLC

Since the channel data are to be used in the PLC, a linkable ARRAY variable must be created there, as shown in the following example:

```
VAR
  aiEL3773_Ch1_DataIn AT%I*: ARRAY[1..10] OF INT;
END_VAR
```

Fig. 127: PLC declaration

This then appears in the list in the System Manager; as a rule it can also be reached via ADS without further measures since PLC variables are always created as ADS symbols in the background.

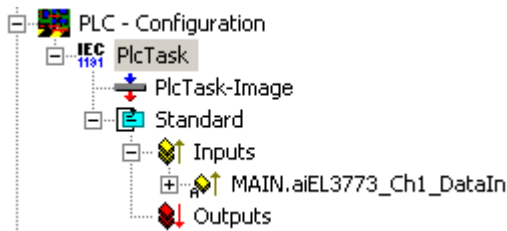

Fig. 128: PLC in the System Manager

Note: the Scope2 can only "see" such variables in the variable browser if TwinCAT and the PLC are in RUN mode.

Step 1b: TwinCAT 2 - free task

So that the linking works, an array variable with the channel data must be present in the system manager; i.e. each oversampling data package must be present in an array. This array variable must be defined and created manually in the System Manager.

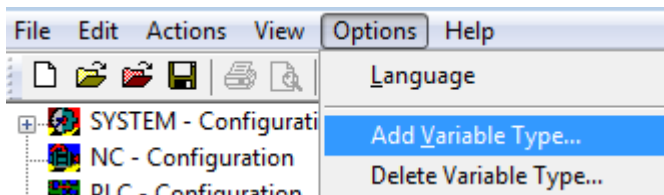

Fig. 129: Add Variable Type

An ARRAY variable of the type as known by the PLC must be created in the syntax as known from the PLC. In this example an array of 0..9 of type INT, i.e. with 10 fields.

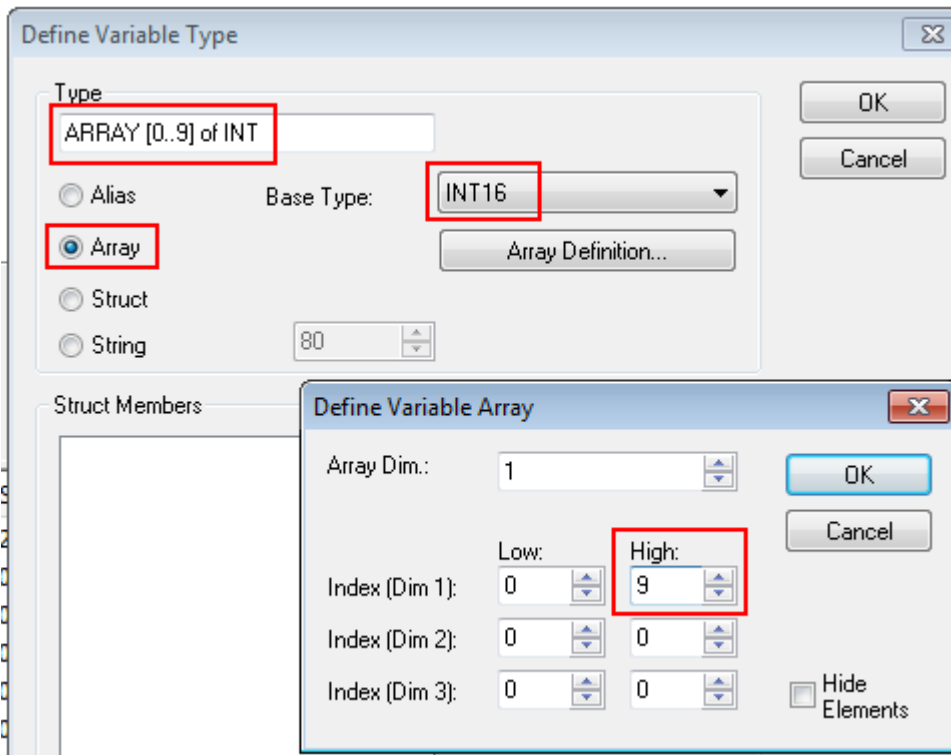

Fig. 130: Definition of the variable type

If this variable is known to the System Manager, an instance of it can be assigned to an additional task with a right-click. It appears in the overview, sorted according to bit size.

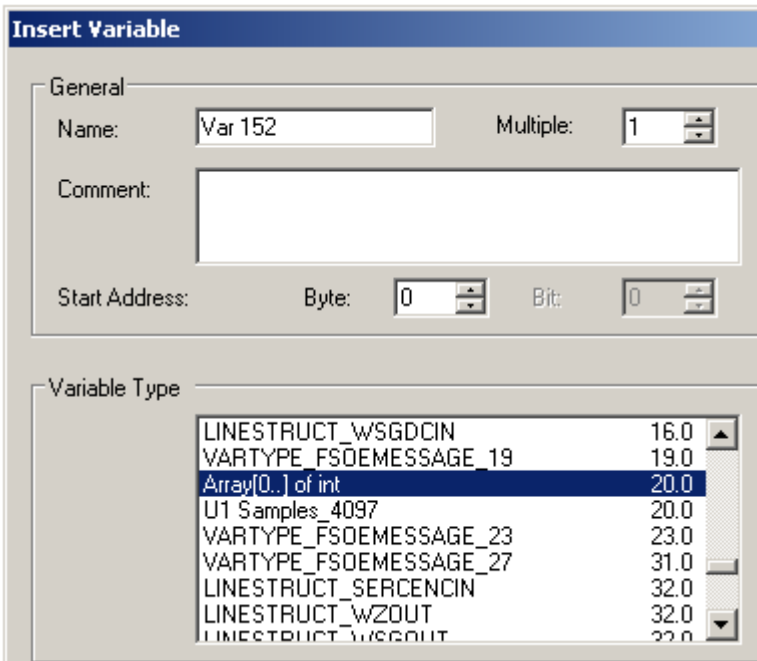

Fig. 131: Overview of declared types

In this example the variable *Var152* is created. It can now be linked with the PDO-Array of the respective channel of the terminal.

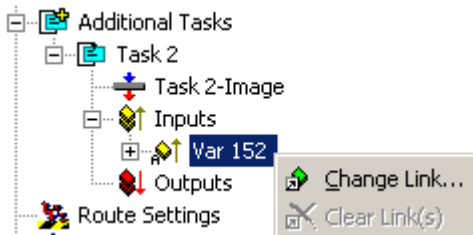

Fig. 132: Linking

If *MatchingSize* is activated in the dialog, the individual channels are offered directly.

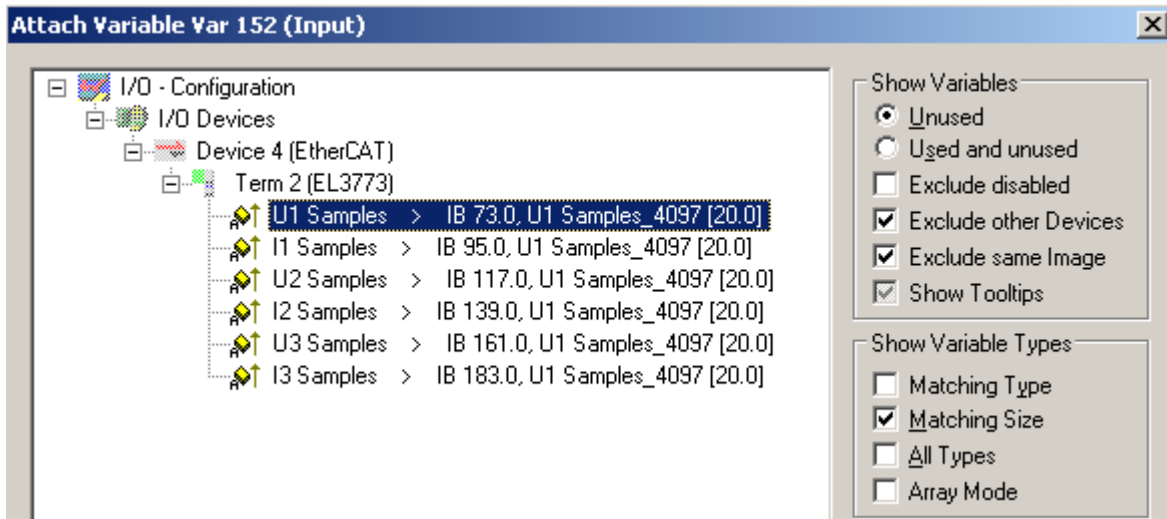

Fig. 133: Array variables of an oversampling terminal

So that the variables can also be found via ADS in the Scope2, the ADS symbols must be activated as well as the Enable Auto-Start, otherwise the task will not run automatically. ADS symbol tables are then created for all variables that have this task in their process data images.

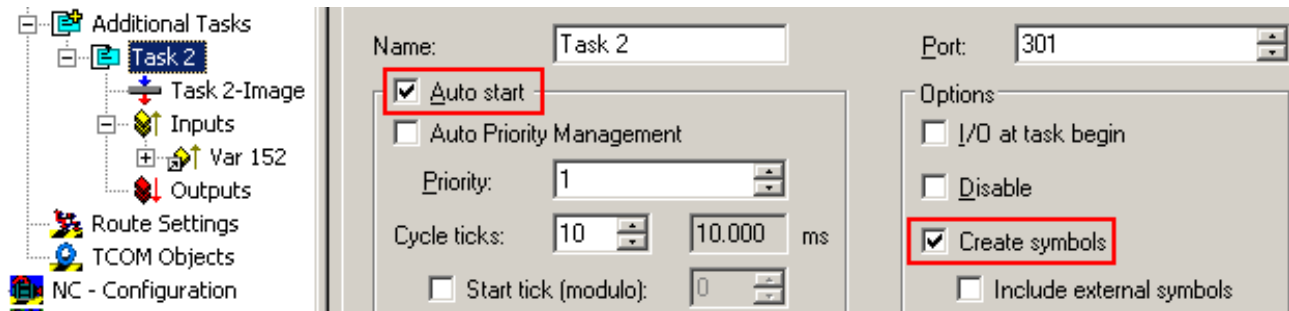

Fig. 134: Settings in the additional task

Step 2: Configuration in the Scope2

So that the linking works, an array variable with the channel data of the respective terminal must be present in the system manager; i.e. each oversampling data package must be present in an array. This array variable must be defined and created manually; [see above \[► 115\]](#).

You can now browse to the variable concerned in the Scope2.

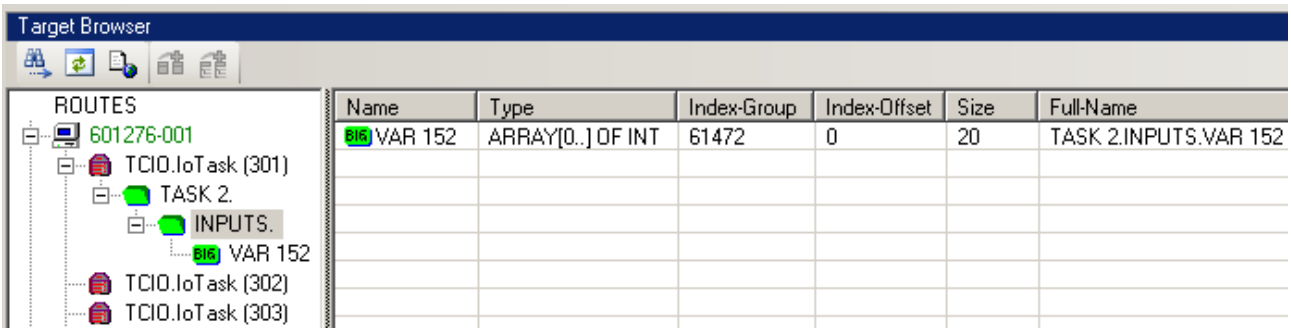

Fig. 135: Variable browser up to the array VAR152

The array is then not to be opened; instead the array symbol is to be selected by right-clicking on *AddSymbol*.

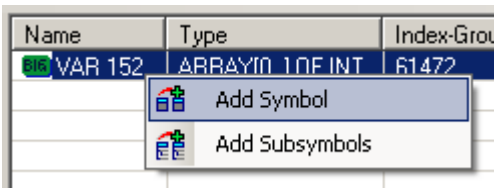

Fig. 136: AddSymbol on the array

ForceOversampling and *Data Type* INT16 must be set in the channel which has now been created. If necessary *SymbolBased* must be temporarily deactivated in addition.

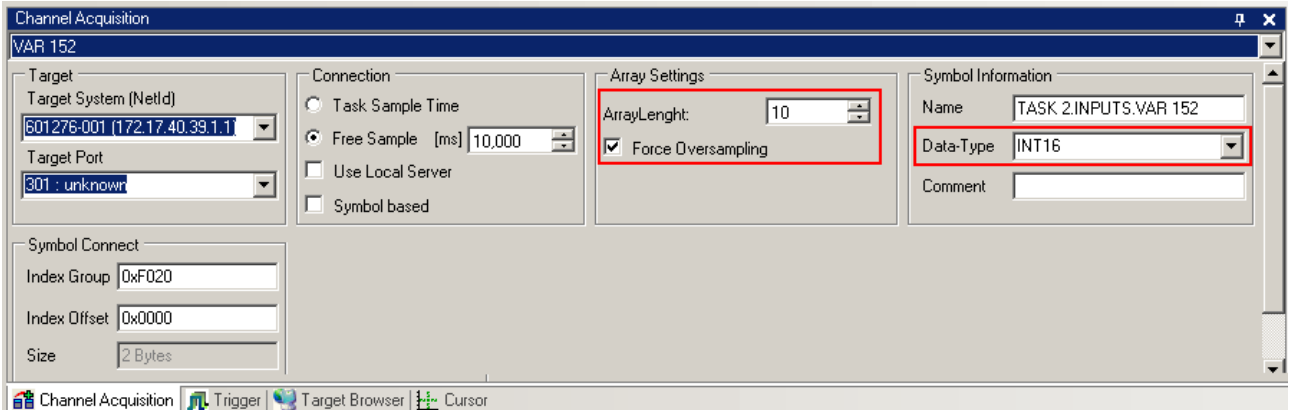

Fig. 137: Channel settings

In order to check that individual oversampling values are really being logged, the *Marks* can be activated in the Scope2. Please observe the interrelationships between task cycle time, sampling time of the Scope2 channel and oversampling factor.

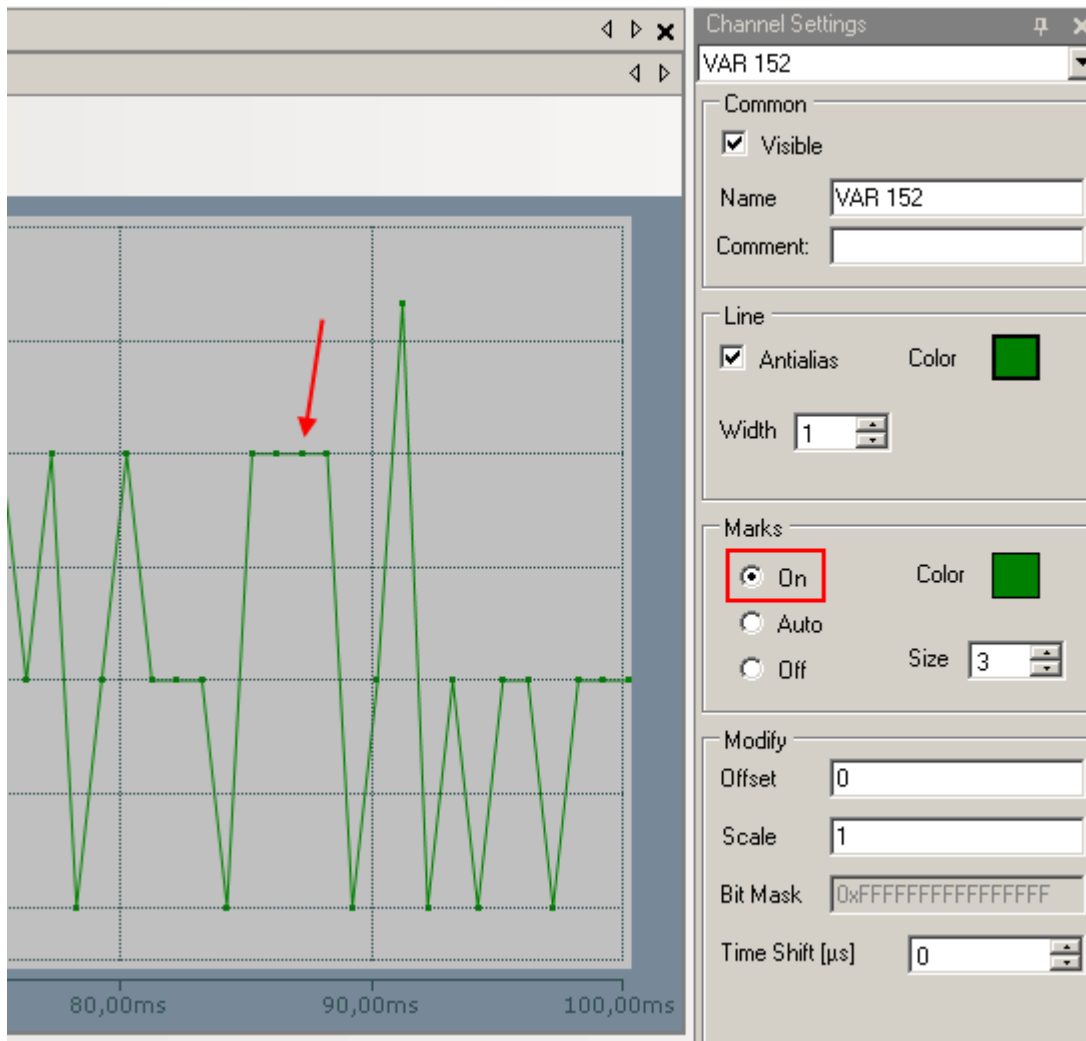

Fig. 138: Activation of the marks

An additional example illustrates the following image by representation of an oversampling – variable from the EL3751 with 10 x oversampling:

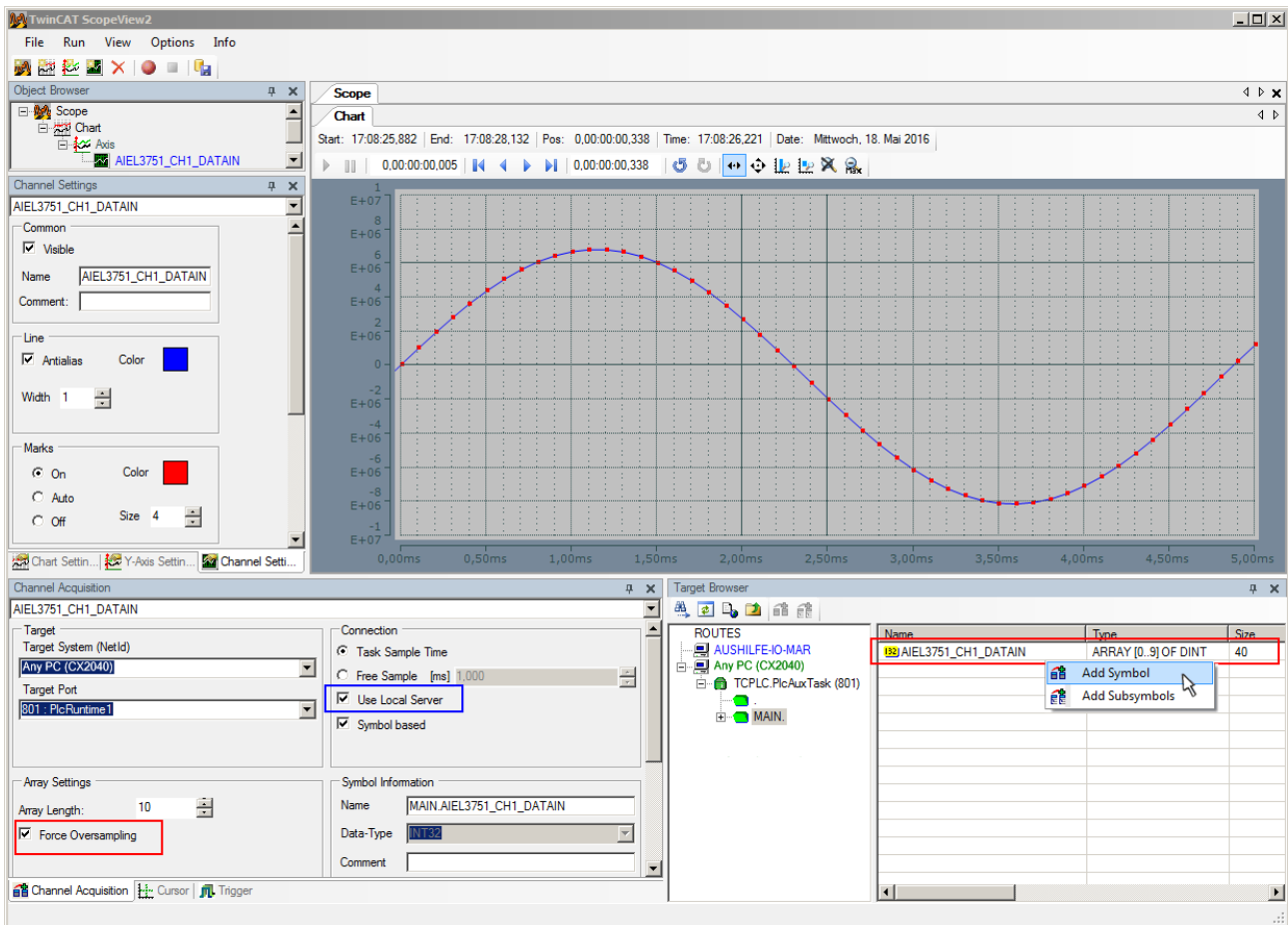

Fig. 139: Illustration of a 10 x oversampling variable of the EL3751 by the Scope2

Within the image was marked subsequently that the oversampling variable originated by the PLC was just added to the Y-axis (observe selection of the PLC-POU name “MAIN” within the “ROUTES” tree). Herewith “Force Oversampling” was activated due to the oversampling variable is not provided by the terminal.

Proceeding with TwinCAT 2/ alternatively via ADS

In former TwinCAT 2 versions (or a lower revision as specified in the [table \[▶ 106\]](#) above) the oversampling PDO of the respective oversampling able terminal can be made visible for the Scope2 by activation of the ADS server.

So the creation of a PLC variable can be disclaimed as well. Therefore the ADS server of the EtherCAT Device where the oversampling able terminal is connected with have to be activated.

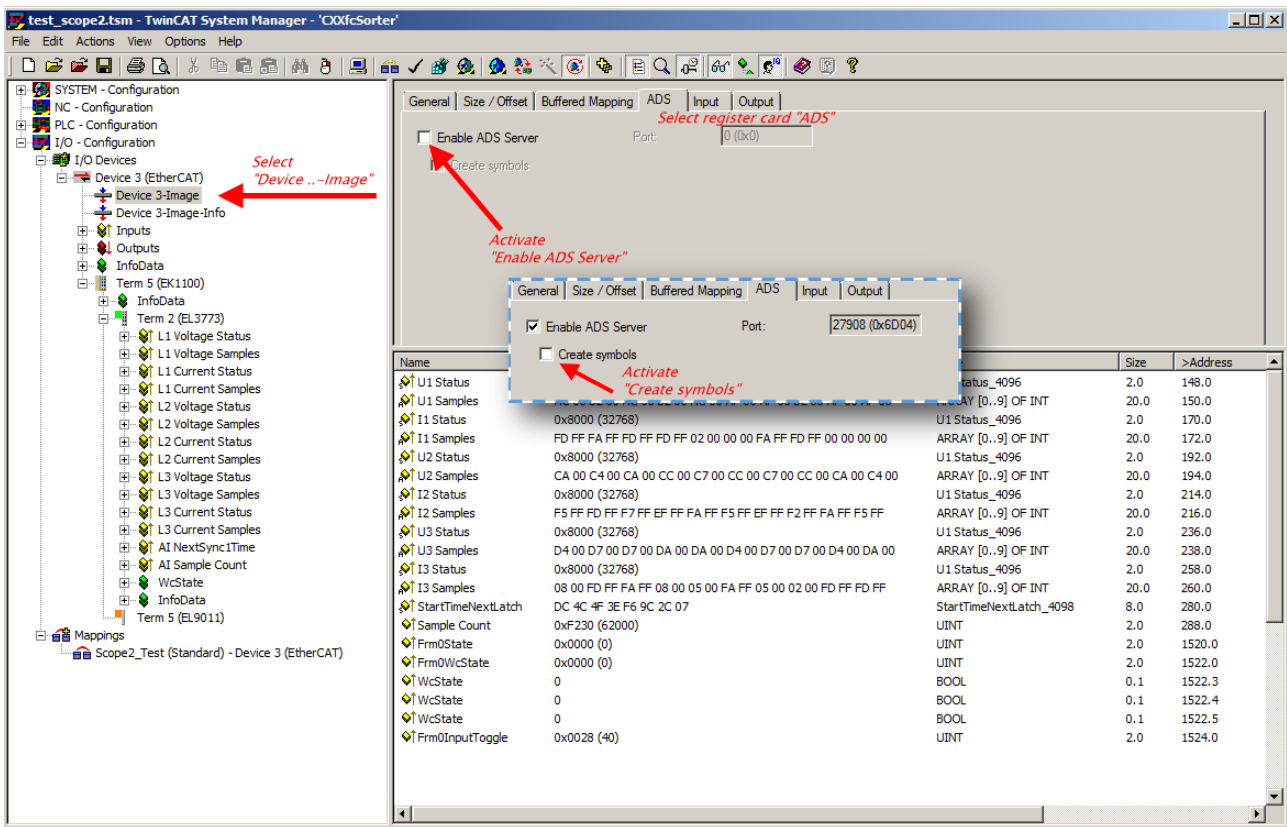

Fig. 140: Activation of the ADS server of the EtherCAT Device (TwinCAT 2)

The activation of the ADS server have to be carried out by selection of the “Device – Image” on the left sided configuration tree:

„I/O – Configuration → I/O Devices → Device .. (EtherCAT) → Device .. – Image“.

Next the register card “ADS” have to be selected to activate each checkbox „Enable ADS Server“ and „Create symbols“ then (the port entry is done automatically).

Thus with the Scope2 process data can be accessed via the target browser without an embedded POU and without a variable reference respectively.

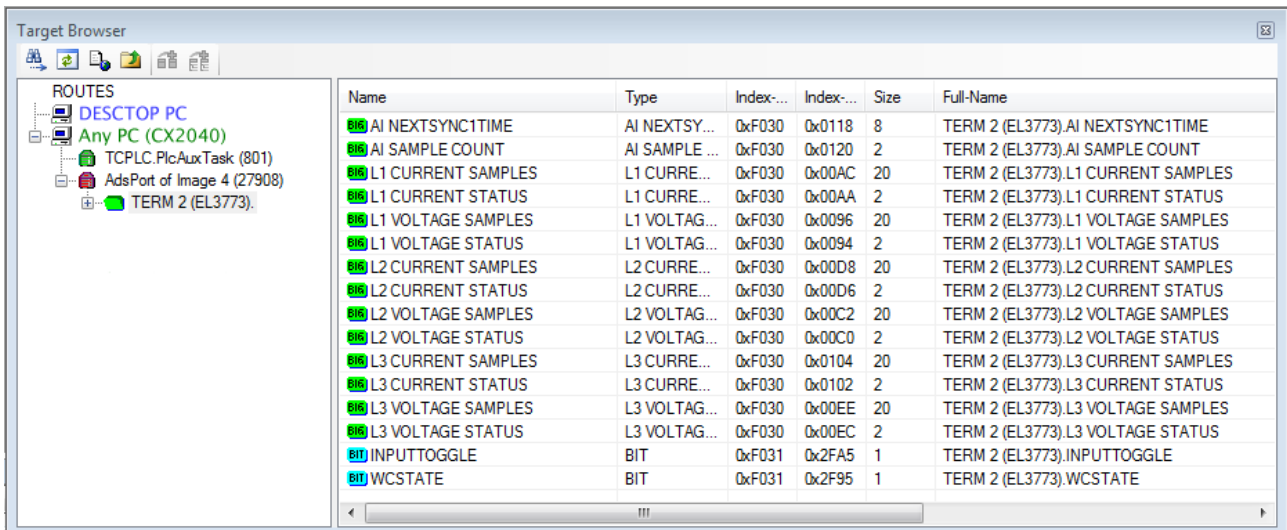

Fig. 141: Direct access of the Scope2 to the terminal's PDOs



Note

Also see Beckhoff Information System

infosys.beckhoff.com → TwinCAT 2 → TwinCAT Supplement → Category Measurement TS3xxx → TS3300 | TwinCAT Scope 2 → Annex → Oversampling record:

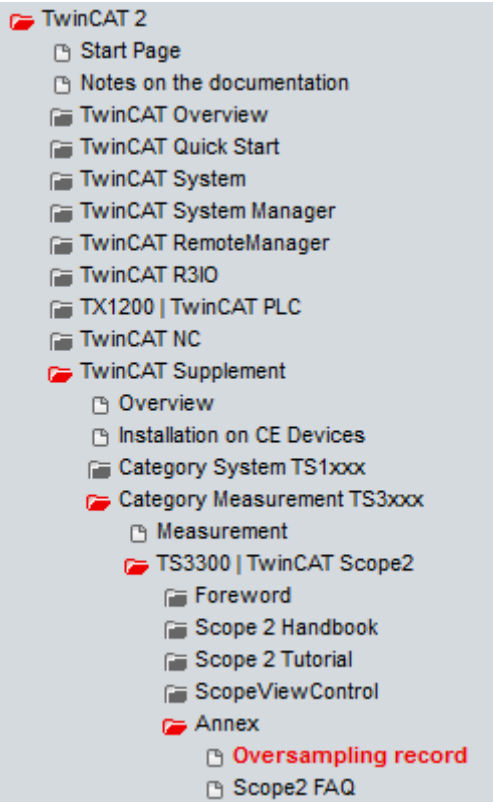

Beckhoff TwinCAT supports the Scope2 with some oversampling devices in a special way by automatically calculating a special ADS array symbol in the background, which appears in the Scope2 in the variable browser. This can be then linked as a variable and automatically brings along the array information.

Name	Type	Index...	Index...	Size	Full-Name
CH1 SAMPLE 0[0]	CH1 SAMPLE_0_TYPE	61488	73	2	TERM 2 (EL3702).CH1 SAMPLE 0[0]
CH1 SAMPLE 0[1]	CH1 SAMPLE_0_TYPE	61488	75	2	TERM 2 (EL3702).CH1 SAMPLE 0[1]
CH1 SAMPLE 0[2]	CH1 SAMPLE_0_TYPE	61488	77	2	TERM 2 (EL3702).CH1 SAMPLE 0[2]
CH1 SAMPLE 0[3]	CH1 SAMPLE_0_TYPE	61488	79	2	TERM 2 (EL3702).CH1 SAMPLE 0[3]
CH1 SAMPLE 0[4]	CH1 SAMPLE_0_TYPE	61488	81	2	TERM 2 (EL3702).CH1 SAMPLE 0[4]
CH1 SAMPLE 0[5]	CH1 SAMPLE_0_TYPE	61488	83	2	TERM 2 (EL3702).CH1 SAMPLE 0[5]
CH1 SAMPLE 0[6]	CH1 SAMPLE_0_TYPE	61488	85	2	TERM 2 (EL3702).CH1 SAMPLE 0[6]
CH1 SAMPLE 0[7]	CH1 SAMPLE_0_TYPE	61488	87	2	TERM 2 (EL3702).CH1 SAMPLE 0[7]
CH1 SAMPLE 0[8]	CH1 SAMPLE_0_TYPE	61488	89	2	TERM 2 (EL3702).CH1 SAMPLE 0[8]
CH1 SAMPLE 0[9]	CH1 SAMPLE_0_TYPE	61488	91	2	TERM 2 (EL3702).CH1 SAMPLE 0[9]
CH1 SAMPLE 0[T10]	CH1 SAMPLE_0_TYPE	61488	73	2	TERM 2 (EL3702).CH1 SAMPLE 0[T10]

Name	Type	Index...	Index...	Size	Full-Name
CH1 VALUE	INT16	61488	73	2	TERM 2 (EL3702).CH1 SAMPLE 0[T10].CH1 VALUE

Fig. 142: Automatically calculated array variable (red) in the Scope2

es muss eine ARRAY-Variable vorliegen die über ADS erreichbar ist. Dies kann eine PLC-Variable oder eine im System Manager definierte ARRAY-Variable sein. Diese wird dann vom Scope2 erkannt.

Summary: an array variable have to be provided which is reachable via ADS. This can be a PLC variable of a POU or a defined array variable by the system manager or alternatively the ADS server of the terminals device is just activated.

6.9 Current transformer

In principle, the choice of current transformer for the EL3773 is not critical. The internal resistance within the current circuit of the EL3773 is so small that it is negligible for the calculation of the total resistances of the current loop. The transformer must be able to supply a secondary rated current of 1 or 1.5 A; the primary rated current I_{pn} can be chosen as desired. Overloading of the EL3773 is permissible up to $1.2 \times I_{pn}/U_{pn}$; see [Technical Data \[► 15\]](#) for max. permissible overvoltage/overcurrent.

Accuracy

Please note that the overall accuracy of the set-up consisting of EL3773 and current transformers to a large degree depends on the accuracy class of the transformers.

 Note	<p>No approval as a billing meter</p> <p>A set-up with a class 0.5 current transformer cannot be approved or authenticated. The EL3773 is not an approved billing meter according to the electricity meter standard (DIN 43 856).</p>
--	--

Current types

The EL3773 can measure any type of current.

Overcurrent limiting factor FS

The overcurrent limiting factor FS of a current transformer indicates at what multiple of the primary rated current the current transformer changes to saturation mode, in order to protect the connected measuring devices.

 Attention	<p>Attention! Risk of damage to the device!</p> <p>The max. permissible input values according to the Technical Data [► 15] must be observed! Additional intermediate transformers must be used in systems in which the overcurrent limiting factors of the transformer allow higher secondary currents!</p>
---	---

Protection against dangerous touch voltages

During appropriate operation of the EL3773 with associated current transformers, no dangerous voltages occur. The secondary voltage is in the range of a few Volts. However, the following faults may lead to excessive voltages:

- Open current path of one or more transformers
- Neutral conductor cut on the voltage measurement side of the EL3773
- General insulation fault

 WARNING	<p>WARNING Risk of electric shock!</p> <p>The complete wiring of the EL3773 must be protected against accidental contact and equipped with associated warnings! The insulation should be designed for the maximum conductor voltage of the system to be measured!</p>
---	--

The EL3773 allows a maximum voltage of 500 V for normal operating conditions. The conductor voltage on the current side must not exceed 500 V! For higher voltages, an intermediate transformer stage should be used!

On the voltage measurement side, a EL3773 is equipped with a protection impedance of 1.8 M Ω . If the neutral conductor is not connected and only one connection on the side of the voltage measurement is live, the resulting voltage against earth in a 3-phase system with a phase-to-phase voltage of 400 V_{AC} is 230 V_{AC}. This should also be measured on the side of the current measurement using a multimeter with an internal resistance of 10 M Ω , which does not represent an insulation fault.

Additional measuring instruments in the current circuit

Please note that the addition of additional measuring instruments (e.g. ammeters) in the current circuit can lead to a significant increase in the total apparent power.

Furthermore, connection I_N of the EL3773 must represent a star point for the three secondary windings. Additional measuring instruments therefore have to be potential-free and must be wired accordingly.

6.10 Notices on analog specifications

Beckhoff I/O devices (terminals, boxes, modules) with analog inputs are characterized by a number of technical characteristic data; refer to the technical data in the respective documents.

Some explanations are given below for the correct interpretation of these characteristic data.

6.10.1 Full scale value (FSV)

An I/O device with an analog input measures over a nominal measuring range that is limited by an upper and a lower limit (initial value and end value); these can usually be taken from the device designation. The range between the two limits is called the measuring span and corresponds to the equation (end value - initial value). Analogous to pointing devices this is the measuring scale (see IEC 61131) or also the dynamic range.

For analog I/O devices from Beckhoff the rule is that the limit with the largest value is chosen as the full scale value of the respective product (also called the reference value) and is given a positive sign. This applies to both symmetrical and asymmetrical measuring spans.

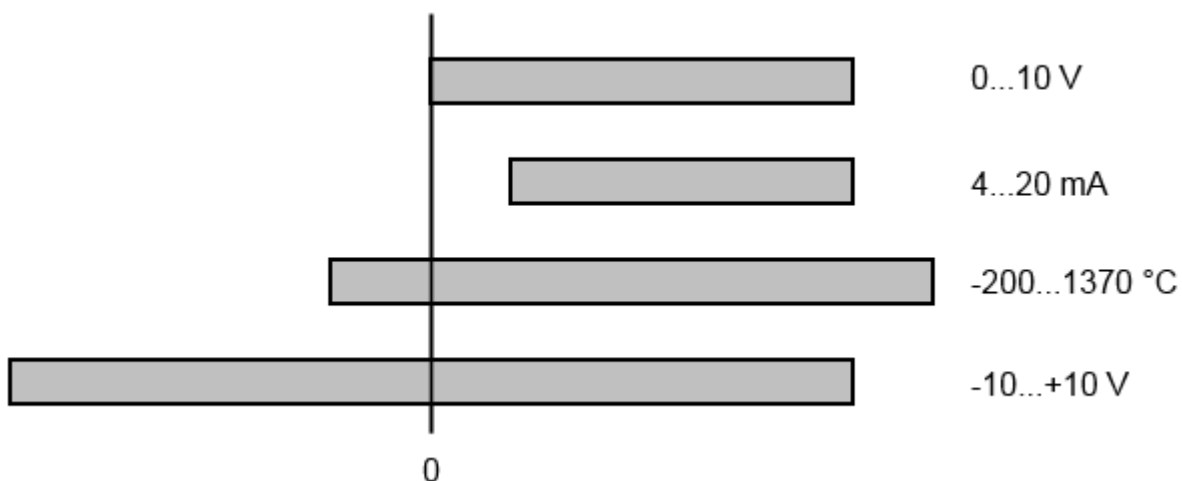

Fig. 143: Full scale value, measuring span

For the above **examples** this means:

- Measuring range 0..10 V: asymmetric unipolar, full scale value = 10 V, measuring span = 10 V
- Measuring range 4..20 mA: asymmetric unipolar, full scale value = 20 mA, measuring span = 16 mA
- Measuring range -200..1370 °C: asymmetric bipolar, full scale value = 1370 °C, measuring span = 1570 °C
- Measuring range -10..+10 V: symmetric bipolar, full scale value = 10 V, measuring span = 20 V

This applies to analog output terminals/ boxes (and related Beckhoff product groups).

6.10.2 Measuring error/ measurement deviation

The relative measuring error (% of the full scale value) is referenced to the full scale value and is calculated as the quotient of the largest numerical deviation from the true value ('measuring error') referenced to the full scale value.

$$\text{Measuring error} = \frac{|\text{max. deviation}|}{\text{full scale value}}$$

The measuring error is generally valid for the entire permitted operating temperature range, also called the 'usage error limit' and contains random and systematic portions of the referred device (i.e. 'all' influences such as temperature, inherent noise, aging, etc.).

It always to be regarded as a positive/negative span with ±, even if it is specified without ± in some cases.

The maximum deviation can also be specified directly.

Example: Measuring range 0..10 V and measuring error < ± 0.3 % full scale value → maximum deviation ± 30 mV in the permissible operating temperature range.



Note

Lower measuring error

Since this specification also includes the temperature drift, a significantly lower measuring error can usually be assumed in case of a constant ambient temperature of the device and thermal stabilization after a user calibration.

This applies to analog output devices.

6.10.3 Temperature coefficient tK [ppm/K]

An electronic circuit is usually temperature dependent to a greater or lesser degree. In analog measurement technology this means that when a measured value is determined by means of an electronic circuit, its deviation from the "true" value is reproducibly dependent on the ambient/operating temperature.

A manufacturer can alleviate this by using components of a higher quality or by software means.

The temperature coefficient specified by Beckhoff allows the user to calculate the expected measuring error outside the basic accuracy at 23 °C.

Due to the extensive uncertainty considerations that are incorporated in the determination of the basic accuracy (at 23 °C), Beckhoff recommends a quadratic summation.

Example: Let the basic accuracy at 23 °C be ±0.01% typ. (full scale value), tK = 20 ppm/K typ.; the accuracy A35 at 35 °C is wanted, hence ΔT = 12 K

$$G_{35} = \sqrt{(0.01\%)^2 + (12K \cdot 20 \frac{\text{ppm}}{\text{K}})^2} = 0.026\% \text{ full scale value, typ}$$

Remarks: ppm ≙ 10⁻⁶ % ≙ 10⁻²

6.10.4 Single-ended/differential typification

For analog inputs Beckhoff makes a basic distinction between two types: *single-ended* (SE) and *differential* (DIFF), referring to the difference in electrical connection with regard to the potential difference.

The diagram shows two-channel versions of an SE module and a DIFF module as examples for all multi-channel versions.

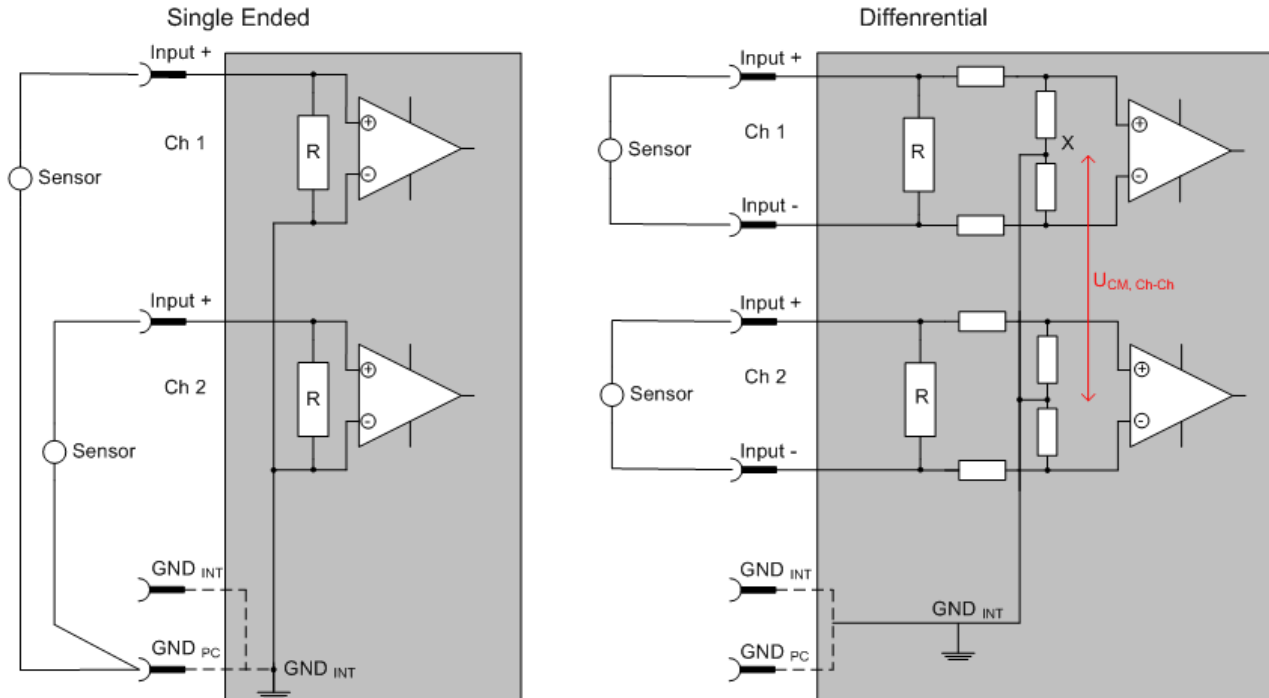

Fig. 144: SE and DIFF module as 2-channel version

Note: Dashed lines indicate that the respective connection may not necessarily be present in each SE or DIFF module. Electrical isolated channels are operating as differential type in general, hence there is no direct relation (voltaic) to ground within the module established at all. Indeed, specified information to recommended and maximum voltage levels have to be taken into account.

The basic rule:

- Analog measurements always take the form of voltage measurements between two potential points. For voltage measurements a large R is used, in order to ensure a high impedance. For current measurements a small R is used as shunt. If the purpose is resistance measurement, corresponding considerations are applied.
 - Beckhoff generally refers to these two points as input+/signal potential and input-/reference potential.
 - For measurements between two potential points two potentials have to be supplied.
 - Regarding the terms "single-wire connection" or "three-wire connection", please note the following for pure analog measurements: three- or four-wire connections can be used for sensor supply, but are not involved in the actual analog measurement, which always takes place between two potentials/wires. In particular this also applies to SE, even though the term suggest that only one wire is required.
- The term "electrical isolation" should be clarified in advance. Beckhoff IO modules feature 1..8 or more analog channels; with regard to the channel connection a distinction is made in terms of:
 - how the channels WITHIN a module relate to each other, or
 - how the channels of SEVERAL modules relate to each other.

The property of electrical isolation indicates whether the channels are directly connected to each other.

- Beckhoff terminals/ boxes (and related product groups) always feature electrical isolation between the field/analog side and the bus/EtherCAT side. In other words, if two analog terminals/ boxes are not connected via the power contacts (cable), the modules are effectively electrically isolated.
- If channels within a module are electrically isolated, or if a single-channel module has no power contacts, the channels are effectively always differential. See also explanatory notes below. Differential channels are not necessarily electrically isolated.
- Analog measuring channels are subject to technical limits, both in terms of the recommended operating range (continuous operation) and the destruction limit. Please refer to the respective terminal/ box documentation for further details.

Explanation

• differential (DIFF)

- Differential measurement is the most flexible concept. The user can freely choose both connection points, input+/signal potential and input-/reference potential, within the framework of the technical specification.
- A differential channel can also be operated as SE, if the reference potential of several sensors is linked. This interconnection may take place via the system GND.
- Since a differential channel is configured symmetrically internally (cf. Fig. SE and DIFF module as 2-channel variant), there will be a mid-potential (X) between the two supplied potentials that is the same as the internal ground/reference ground for this channel. If several DIFF channels are used in a module without electrical isolation, the technical property V_{CM} (common-mode voltage) indicates the degree to which the mean voltage of the channels may differ.
- The internal reference ground may be accessible as connection point at the terminal/ box, in order to stabilize a defined GND potential in the terminal/ box. In this case it is particularly important to pay attention to the quality of this potential (noiselessness, voltage stability). At this GND point a wire may be connected to make sure that $V_{CM,max}$ is not exceeded in the differential sensor cable.
If differential channels are not electrically isolated, usually only one $V_{CM,max}$ is permitted. If the channels are electrically isolated this limit should not apply, and the channels voltages may differ up to the specified separation limit.
- Differential measurement in combination with correct sensor wiring has the special advantage that any interference affecting the sensor cable (ideally the feed and return line are arranged side by side, so that interference signals have the same effect on both wires) has very little effect on the measurement, since the potential of both lines varies jointly (hence the term common mode). In simple terms: Common-mode interference has the same effect on both wires in terms of amplitude and phasing.
- Nevertheless, the suppression of common-mode interference within a channel or between channels is subject to technical limits, which are specified in the technical data.
- Further helpfully information on this topic can be found on the documentation page *Configuration of 0/4..20 mA differential inputs* (see documentation for the EL30xx terminals, for example).

• Single Ended (SE)

- If the analog circuit is designed as SE, the input/reference wire is internally fixed to a certain potential that cannot be changed. This potential must be accessible from outside on at least one point for connecting the reference potential, e.g. via the power contacts (cable).
- In other words, in situations with several channels SE offers users the option to avoid returning at least one of the two sensor cables to the terminal/ box (in contrast to DIFF). Instead, the reference wire can be consolidated at the sensors, e.g. in the system GND.
- A disadvantage of this approach is that the separate feed and return line can result in voltage/ current variations, which a SE channel may no longer be able to handle. See common-mode interference. A V_{CM} effect cannot occur, since the module channels are internally always 'hard-wired' through the input/reference potential.

Typification of the 2/3/4-wire connection of current sensors

Current transducers/sensors/field devices (referred to in the following simply as 'sensor') with the industrial 0/4-20 mA interface typically have internal transformation electronics for the physical measured variable (temperature, current, etc.) at the current control output. These internal electronics must be supplied with energy (voltage, current). The type of cable for this supply thus separates the sensors into *self-supplied* or *externally supplied* sensors:

Self-supplied sensors

- The sensor draws the energy for its own operation via the sensor/signal cable + and -. So that enough energy is always available for the sensor's own operation and open-circuit detection is possible, a lower limit of 4 mA has been specified for the 4-20 mA interface; i.e. the sensor allows a minimum current of 4 mA and a maximum current of 20 mA to pass.
- 2-wire connection see Fig. *2-wire connection*, cf. IEC60381-1
- Such current transducers generally represent a current sink and thus like to sit between + and – as a 'variable load'. Refer also to the sensor manufacturer's information.

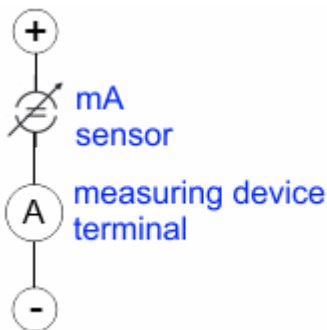

Fig. 145: 2-wire connection

Therefore, they are to be connected according to the Beckhoff terminology as follows:

preferably to '**single-ended**' inputs if the +Supply connections of the terminal/ box are also to be used - connect to +Supply and Signal

they can, however, also be connected to '**differential**' inputs, if the termination to GND is then manufactured on the application side – to be connected with the right polarity to +Signal and –Signal. It is important to refer to the information page *Configuration of 0/4..20 mA differential inputs* (see documentation for the EL30xx terminals, for example)!

Externally supplied sensors

- 3- and 4-wire connection see Fig. *Connection of externally supplied sensors*, cf. IEC60381-1
 - the sensor draws the energy/operating voltage for its own operation from 2 supply cables of its own. One or two further sensor cables are used for the signal transmission of the current loop:
 - 1 sensor cable: according to the Beckhoff terminology such sensors are to be connected to '**single-ended**' inputs in 3 cables with +/-Signal lines and if necessary FE/shield
 - 2 sensor cables: for sensors with 4-wire connection based on +supply/-supply/+signal/-signal, check whether +signal can be connected to +supply or –signal to –supply.
 - Yes: then you can connect accordingly to a Beckhoff '**single-ended**' input.
 - No: the Beckhoff '**differential**' input for +Signal and –Signal is to be selected; +Supply and –Supply are to be connected via additional cables.
- It is important to refer to the information page *Configuration of 0/4..20 mA differential inputs* (see documentation for the EL30xx terminals, for example)!

Note: expert organizations such as NAMUR demand a usable measuring range <4 mA/>20 mA for error detection and adjustment, see also NAMUR NE043.

The Beckhoff device documentation must be consulted in order to see whether the respective device supports such an extended signal range.

Usually there is an internal diode existing within unipolar terminals/ boxes (and related product groups), in this case the polarity/direction of current have to be observed.

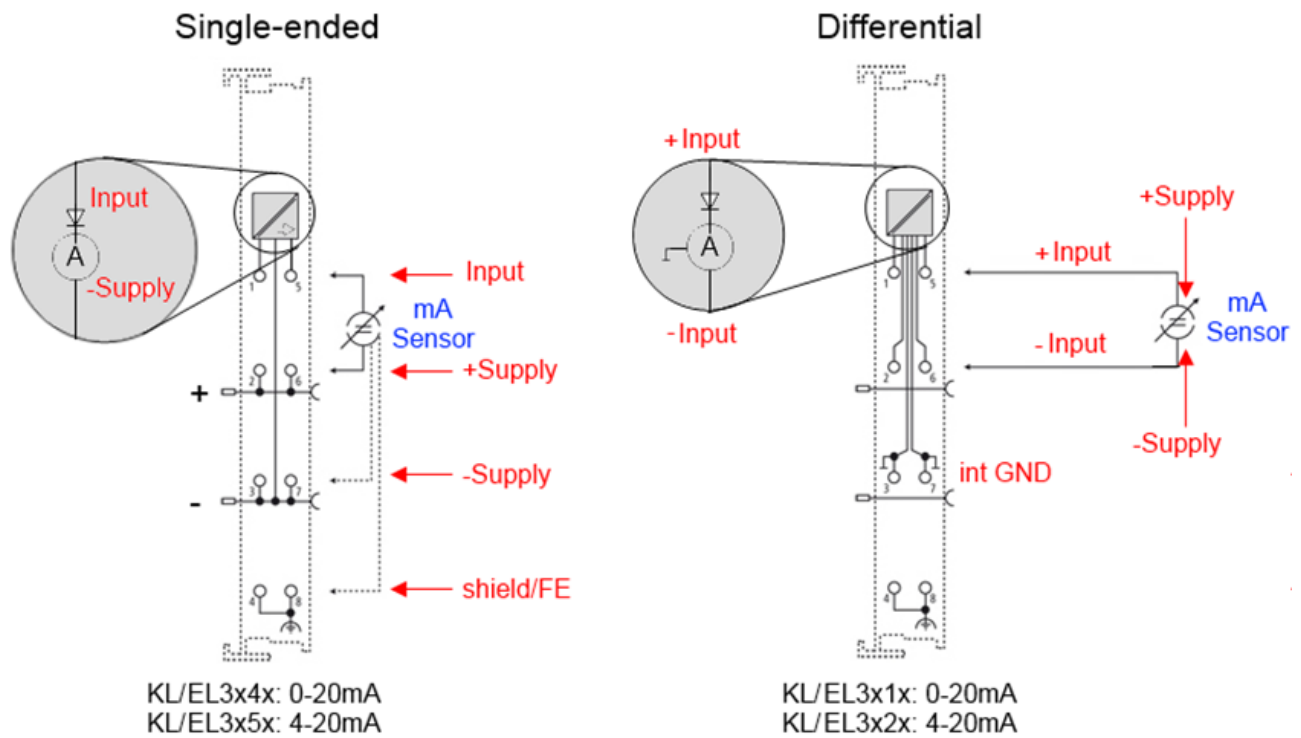

Fig. 146: Connection of externally supplied sensors

Classification of the Beckhoff terminals/ boxes - Beckhoff 0/4-20 mA terminals/ boxes (and related product groups) are available as **differential** and **single-ended** terminals/ boxes (and related product groups):

Single-ended

EL3x4x: 0-20 mA, EL3x5x: 4-20 mA; KL and related product groups exactly the same
Preferred current direction because of internal diode
Designed for the connection of externally-supplied sensors with a 3/4-wire connection
Designed for the connection of self-supplied sensors with a 2-wire connection

Differential

EL3x1x: 0-20 mA, EL3x2x: 4-20 mA; KL and related product groups exactly the same
Preferred current direction because of internal diode
The terminal/ box is a passive differential current measuring device; passive means that the sensor is not supplied with power.

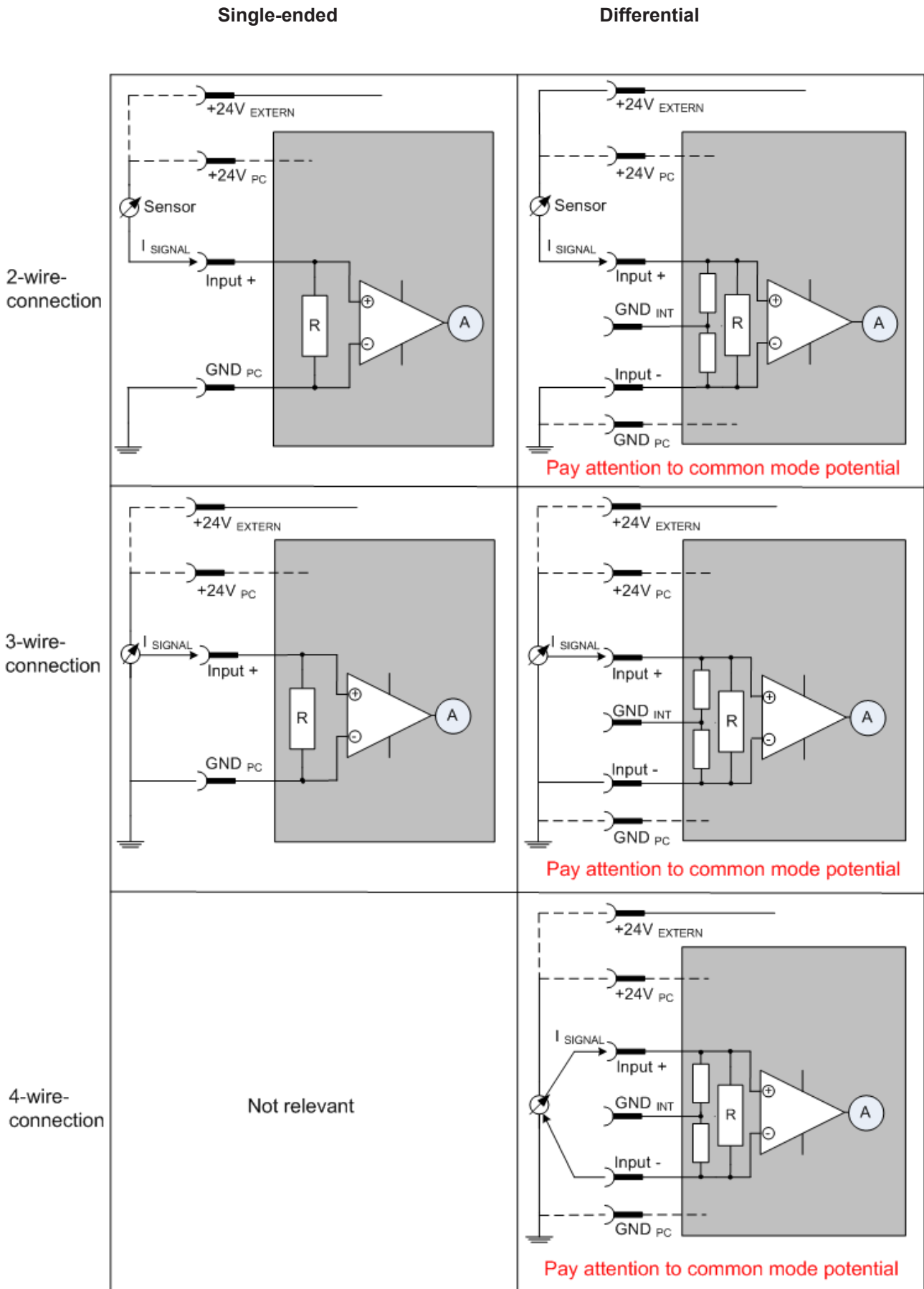

Fig. 147: 2-, 3- and 4-wire connection at single-ended and differential inputs

6.10.5 Common-mode voltage and reference ground (based on differential inputs)

Common-mode voltage (V_{cm}) is defined as the average value of the voltages of the individual connections/ inputs and is measured/specified against reference ground.

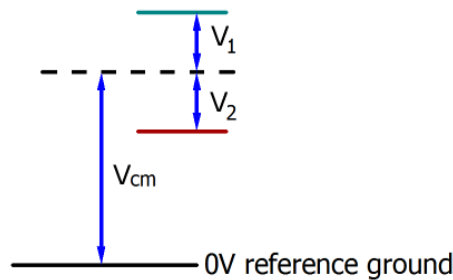

Fig. 148: Common-mode voltage (V_{cm})

The definition of the reference ground is important for the definition of the permitted common-mode voltage range and for measurement of the common-mode rejection ratio (CMRR) for differential inputs.

The reference ground is also the potential against which the input resistance and the input impedance for single-ended inputs or the common-mode resistance and the common-mode impedance for differential inputs is measured.

The reference ground is usually accessible at or near the terminal/ box, e.g. at the terminal contacts, power contacts (cable) or a mounting rail. Please refer to the documentation regarding positioning. The reference ground should be specified for the device under consideration.

For multi-channel terminals/ boxes with resistive (=direct, ohmic, galvanic) or capacitive connection between the channels, the reference ground should preferably be the symmetry point of all channels, taking into account the connection resistances.

Reference ground samples for Beckhoff IO devices:

1. Internal AGND fed out: EL3102/EL3112, resistive connection between the channels
2. 0V power contact: EL3104/EL3114, resistive connection between the channels and AGND; AGND connected to 0V power contact with low-resistance
3. Earth or SGND (shield GND):
 - EL3174-0002: Channels have no resistive connection between each other, although they are capacitively coupled to SGND via leakage capacitors
 - EL3314: No internal ground fed out to the terminal points, although capacitive coupling to SGND

6.10.6 Dielectric strength

A distinction should be made between:

- Dielectric strength (destruction limit): Exceedance can result in irreversible changes to the electronics
 - Against a specified reference ground
 - Differential
- Recommended operating voltage range: If the range is exceeded, it can no longer be assumed that the system operates as specified
 - Against a specified reference ground
 - Differential

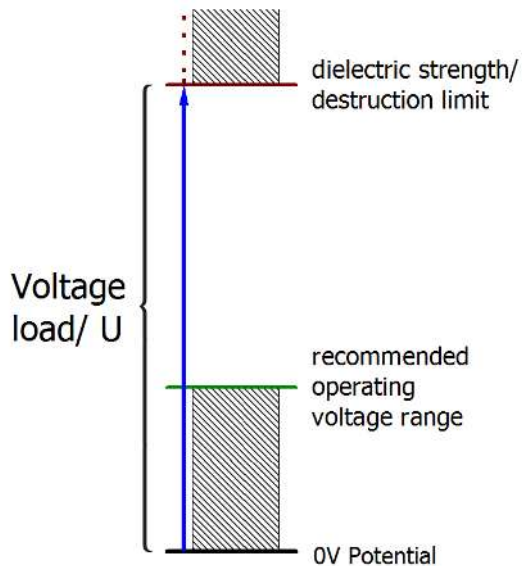

Fig. 149: recommended operating voltage range

The device documentation may contain particular specifications and timings, taking into account:

- Self-heating
- Rated voltage
- Insulating strength
- Edge steepness of the applied voltage or holding periods
- Normative environment (e.g. PELV)

6.10.7 Temporal aspects of analog/digital conversion

The conversion of the constant electrical input signal to a value-discrete digital and machine-readable form takes place in the analog Beckhoff EL/KL/EP input modules with ADC (analog digital converter). Although different ADC technologies are in use, from a user perspective they all have a common characteristic: after the conversion a certain digital value is available in the controller for further processing. This digital value, the so-called analog process data, has a fixed temporal relationship with the “original parameter”, i.e. the electrical input value. Therefore, corresponding temporal characteristic data can be determined and specified for Beckhoff analogue input devices.

This process involves several functional components, which act more or less strongly in every AI (analog input) module:

- the electrical input circuit
- the analog/digital conversion
- the digital further processing
- the final provision of the process and diagnostic data for collection at the fieldbus (EtherCAT, K-bus, etc.)

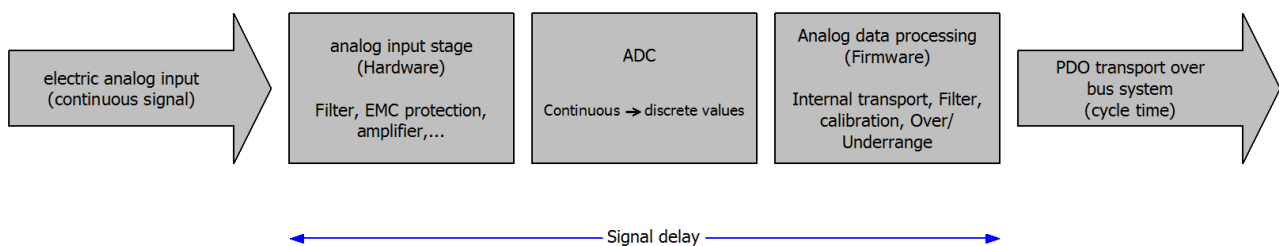

Fig. 150: Signal processing analog input

Two aspects are crucial from a user perspective:

- “How often do I receive new values?”, i.e. a sampling rate in terms of speed with regard to the device/channel
- What delay does the (whole) AD conversion of the device/channel cause?
 - i.e. the hardware and firmware components in its entirety. For technological reasons, the signal characteristics must be taken into account when determining this information: the run times through the system differ, depending on the signal frequency.

This is the “external” view of the “Beckhoff AI channel” system – internally the signal delay in particular is composed of different components: hardware, amplifier, conversion itself, data transport and processing. Internally a higher sampling rate may be used (e.g. in the deltaSigma converters) than is offered “externally” from the user perspective. From a user perspective of the “Beckhoff AI channel” component this is usually irrelevant or is specified accordingly, if it is relevant for the function.

For Beckhoff AI devices the following specification parameters for the AI channel are available for the user from a temporal perspective:

1. Minimum conversion time [ms, μ s]

= the reciprocal value of the maximum **sampling rate** [sps, samples per second]:

Indicates how often the analog channel makes a newly detected process data value available for collection by the fieldbus. Whether the fieldbus (EtherCAT, K-bus) fetches the value with the same speed (i.e. synchronous), or more quickly (if the AI channel operates in slow FreeRun mode) or more slowly (e.g. with oversampling), is then a question of the fieldbus setting and which modes the AI device supports.

For EtherCAT devices the so-called toggle bit indicates (by toggling) for the diagnostic PDOs when a newly determined analog value is available.

Accordingly, a maximum conversion time, i.e. a smallest sampling rate supported by the AI device, can be specified.

Corresponds to IEC 61131-2, section 7.10.2 2, “Sampling repeat time”

2. Typical signal delay

Corresponds to IEC 61131-2, section 7.10.2 1, “Sampling duration”. From this perspective it includes all internal hardware and firmware components, but not “external” delay components from the fieldbus or the controller (TwinCAT).

This delay is particularly relevant for absolute time considerations, if AI channels also provide a time stamp that corresponds to the amplitude value – which can be assumed to match the physically prevailing amplitude value at the time.

Due to the frequency-dependent signal delay time, a dedicated value can only be specified for a given signal. The value also depends on potentially variable filter settings of the channel.

A typical characterization in the device documentation may be:

2.1 Signal delay (step response)

Keywords: Settling time

The square wave signal can be generated externally with a frequency generator (note impedance!)

The 90 % limit is used as detection threshold.

The signal delay [ms, μ s] is then the time interval between the (ideal) electrical square wave signal and the time at which the analog process value has reached the 90 % amplitude.

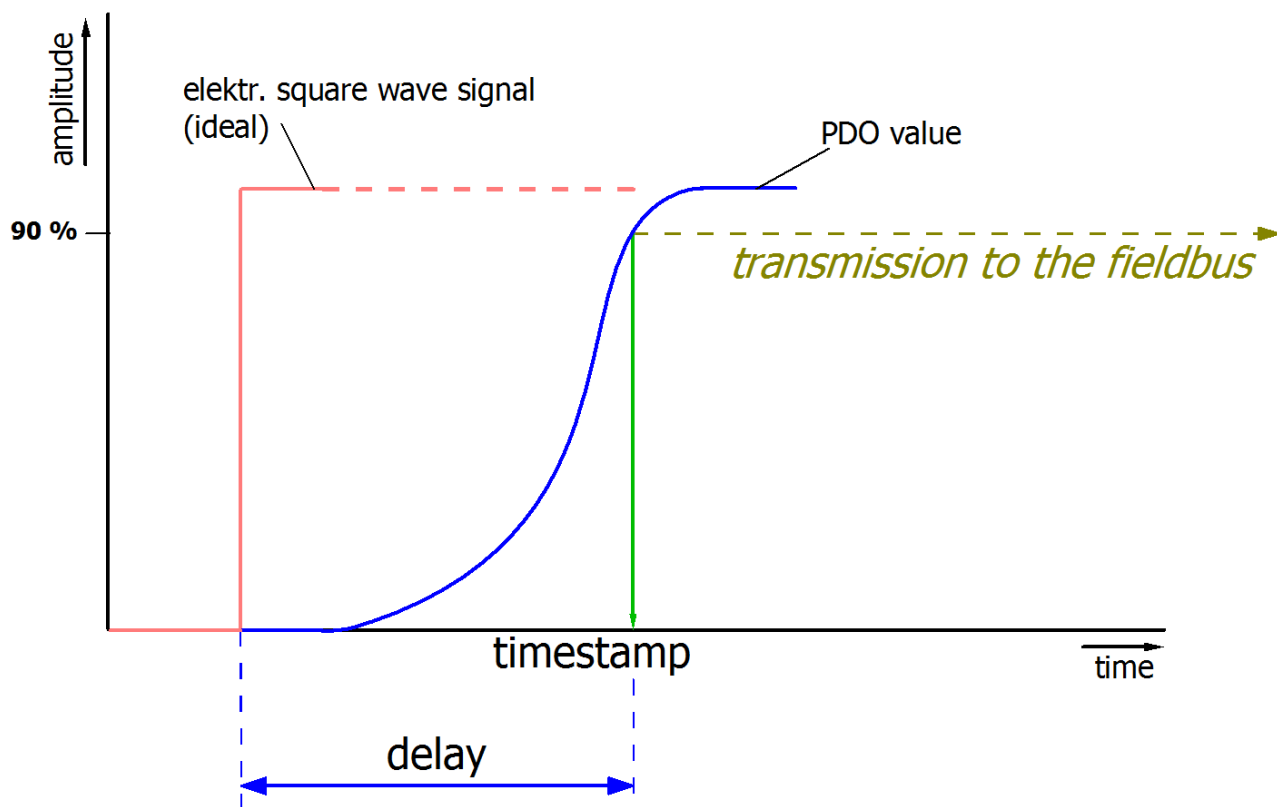

Fig. 151: Diagram signal delay (step response)

2.2 Signal delay (linear)

Keyword: Group delay

Describes the delay of a signal with constant frequency

A test signal can be generated externally with a frequency generator, e.g. as sawtooth or sine. A simultaneous square wave signal would be used as reference.

The signal delay [ms, μ s] is then the interval between the applied electrical signal with a particular amplitude and the moment at which the analog process value reaches the same value.

A meaningful range must be selected for the test frequency, e.g. 1/20 of the maximum sampling rate.

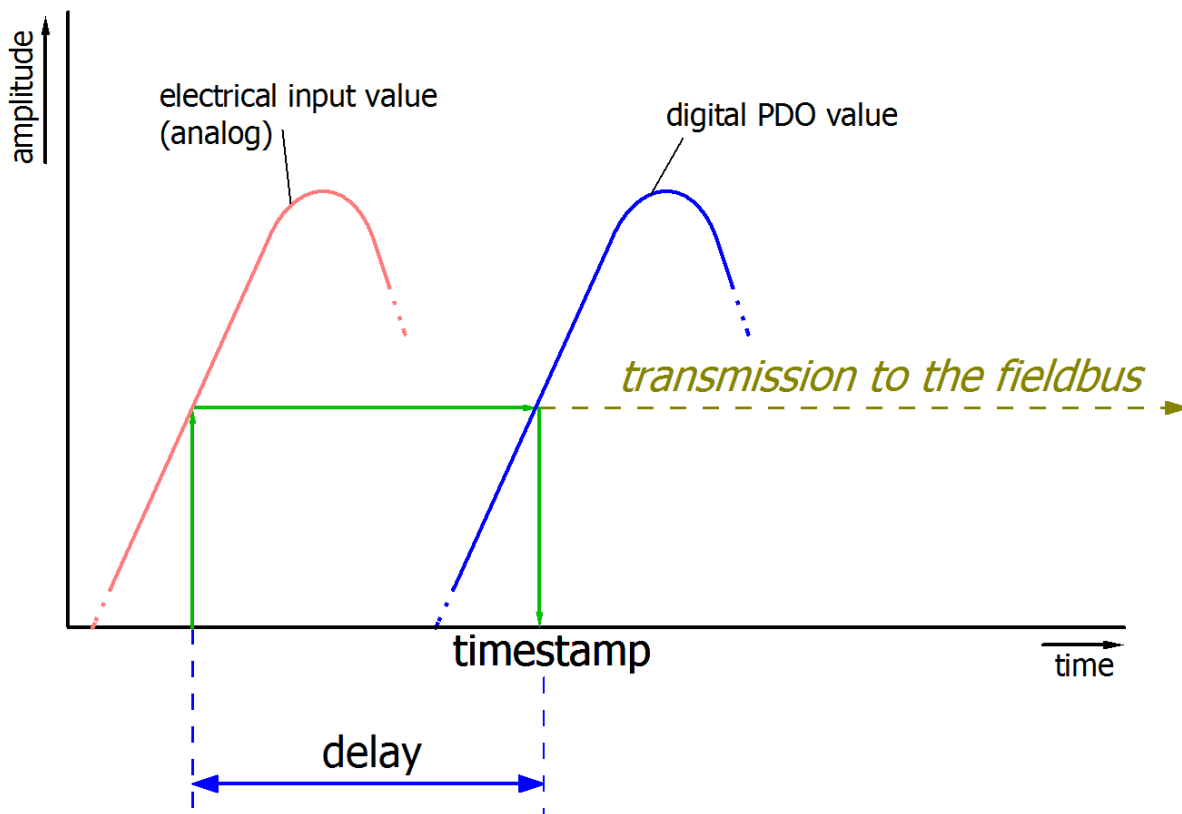

Fig. 152: Diagram signal delay (linear)

3. Additional information:

may be provided in the specification, e.g.

3.1 Actual sampling rate of the ADC (if different from the channel sampling rate)

3.2 Time correction values for run times with different filter settings

...

6.11 Example programs



Note

Using the example programs

This document contains sample applications of our products for certain areas of application. The application notices provided here are based on typical features of our products and only serve as examples. The notices contained in this document explicitly do not refer to specific applications. The customer is therefore responsible for assessing and deciding whether the product is suitable for a particular application.

We accept no responsibility for the completeness and correctness of the source code contained in this document. We reserve the right to modify the content of this document at any time and accept no responsibility for errors and missing information.

The program presented below serves as an initial introduction to the options for evaluating the data from a mains monitoring terminal. The user is free to change the program to suit his ideas or to use only part of the code.

Table of contents

- [Example 1: Diagnosis and evaluation of input data \[▶ 136\]](#)
- [Commissioning of the example program \[▶ 139\]](#)
- [Adaptation of the PLC to the selected oversampling factor \[▶ 139\]](#)
- [Adaptation of the calculation of voltage and current from the raw data \[▶ 140\]](#)
- [Description of the function of the example program](#)
- [Visualization \[▶ 141\]](#)
- [Selection of the size of the FIFO buffer \[▶ 142\]](#)
- [Performance of the calculations \[▶ 143\]](#)
- [Starting the example program \[▶ 144\]](#)
 - [Procedure for starting the program \[▶ 145\]](#)

6.11.1 Example 1: Diagnosis and evaluation of input data

 Download: (<https://infosys.beckhoff.com/content/1033/el3773/Resources/zip/2041395339.zip>)

**Note****Usage of this example program**

This example program was created on a powerful Beckhoff C6920 Industrial PC and requires high computing power.

While testing this program, the following factors should be considered:

- In all tasks, the exceeding counters should not increment and an even utilization should be displayed.

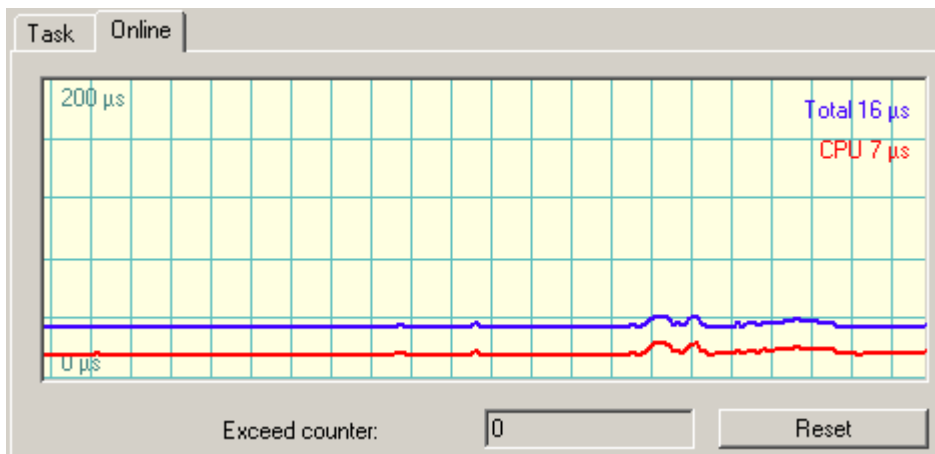

- If an uneven execution of the PLC program is unavoidable, the activation of *IoAtTaskBegin* should be considered

Run-Time No.:	<input type="text" value="1"/>	Port:	<input type="text" value="801"/>
Target System:	<input type="text" value="x86"/>	<input type="checkbox"/> I/O at Task Begin	

- You should decrease the buffer size, if necessary, advice regarding this is given below
- If the EL3773 indicates sync errors in the ADS logger window

(EL3773)' (1016): abnormal state change (from 'OP' to 'SAFEOP') with code 0x2c, 'SYNC0 or SYNC1 failed'. Try to go back to 'OP'...

(EL3773)' (1016): state change to 'OP' finished

or in the DiagMessages,

```

11:20:01 19... (0x1135) Angeforderter Status OP erreicht
11:20:00 88... (0x8140) Synchronisierungsfehler
11:20:00 88... (0x8143) Jitter zu groß ( >> 1830 µs)
11:20:00 16... (0x1135) Angeforderter Status OP erreicht
11:19:59 85... (0x8140) Synchronisierungsfehler
11:19:59 85... (0x8143) Jitter zu groß ( >> 1830 µs)
    
```

the frames are not arriving regularly at the EL3773. In this case the above points should be checked.

- In particular the synchronization can become more difficult if such effects occur during the start-up phase. This may also prevent the EL3773 from entering the OP state.

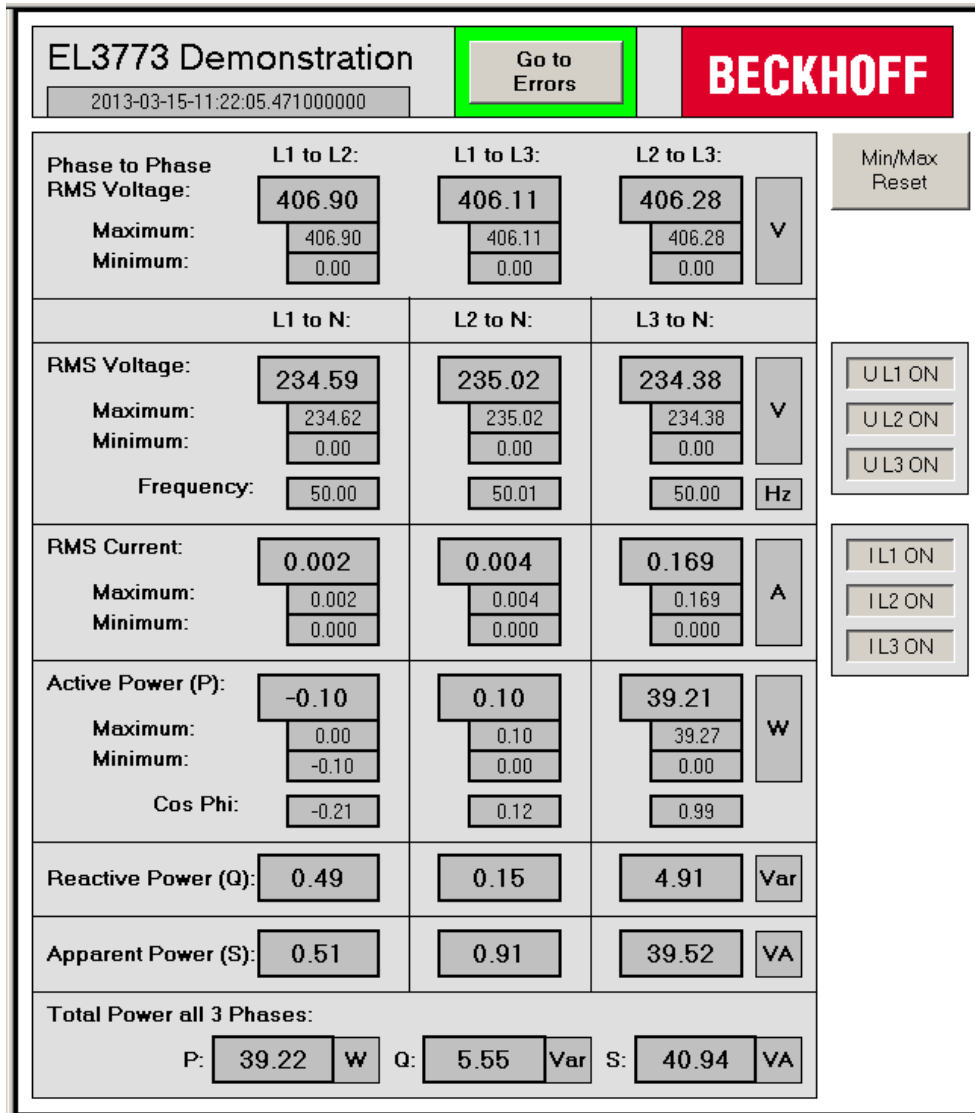

Fig. 153: Visualization of example program for EL3773

In this example the input data of an EL3773 will be checked for validity and processed:

- Cycle time and oversampling freely configurable, presetting: 5 ms cycle time, 20-fold oversampling
- WC, State, EtherCAT Master DevState, WcState, FrmState and status of the channels are cyclically checked
- The data from each cycle are placed in a FIFO buffer so that, for example, the evaluation can take place at a higher level. The size of the FIFO buffer is freely configurable
- If all data are valid, the following calculations take place:
 - RMS voltage for each channel
 - RMS current for each channel

- RMS voltage of the external conductors
- Apparent, active and reactive power for each channel and in total
- Power factor ($\cos \varphi$) for each phase
- Frequency of each voltage channel

The following list shows an overview of the calculation of the values. More details in the item "Performance of the calculations"

	Calculation	Calculation of the value shown in the visu
RMS phase conductors	$u_{pp} = \sqrt{\frac{1}{n} \sum_1^n (u1(t) - u2(t))^2}$	$u_{pp,avg} = \frac{1}{n} \sum_1^n u_{pp}$
RMS phase	$u_{rms} = \sqrt{\frac{1}{n} \sum_1^n u(t)^2}$	$u_{rms,avg} = \frac{1}{n} \sum_1^n u_{rms}$
P	$P = \frac{1}{n} \sum_1^n u(t) * i(t)$	$P_{avg} = \frac{1}{n} \sum_1^n P(t)$
S	$S = u_{rms} * i_{rms}$	$S_{avg} = \frac{1}{n} \sum_1^n S(t)$
Q	$Q = \sqrt{S^2 - P^2}$	$Q_{avg} = \frac{1}{n} \sum_1^n Q(t)$
Cos Phi	$\cos \varphi = \frac{P}{S}$	see left

Fig. 154: Overview of the performance of the calculations

- The calculations can be switched on and off for each individual channel
- On the basis of the supplied time stamp of the next sample, all other samples are provided with 64 bit DC time stamps; these are necessary for determining the frequency
- Default values are passed on in case of invalid input data; the error which occurred is displayed in the visualization

Connection diagram:

- The wiring is done as described in the chapter [Application examples for AC \[► 102\]](#)
- The voltage is measured via connections L1, L2, L3 and N.
- The current is measured via three [current transformers \[► 123\]](#) and the connections I_{L1} , I_{L2} , I_{L3} and I_N (star point of the current transformers).

The program serves as an initial introduction to the options for evaluating the data from a mains monitoring terminal. The user is free to change the program to suit his ideas or to use only part of the code.

**Note****CPU utilization when using the program**

The CPU utilization when using the program strongly depends on the selected cycle time and the selected size of the FIFO data buffer. The results of internal company tests have shown that CPU utilization is approximately anti-proportional to the cycle time (i.e. the faster the cycle time, the greater the CPU utilization) and proportional to the size of the FIFO data buffer. The default settings of a 5 ms cycle time and a FIFO size of 800 places resulted in a CPU utilization of about 35% with the following hardware:

- CPU Intel Celeron 1.90 Ghz, 2 cores
- 1024MB DDR3-RAM
- Windows XP Professional SP3
- TwinCAT Version 2.11 (Build 2230)

⇒ The selected oversampling factor had hardly any effect on the CPU utilization in the tests.

**Note****Use of the program with the oversampling factor 1**

If the operating mode 'DC Oversampling 1' is selected in the System Manager, then the PDO assignment 0x1A60 must be activated in the 'Process Data' tab for the calculation of the 'StartTimeNextLatch'. After that the PDO must be linked with the corresponding variable (default: MAIN.fbEL3773.uliStartTimeNextLatch).

6.11.2 Commissioning of the example program

The program is already pre-configured such that the settings in the PLC described below do not absolutely have to be changed. To start you can jump directly to the item "Procedure for starting the program"

Adaptation of the PLC to the selected oversampling factor

Adaptation of the PLC to the selected oversampling factor

The structure of the program enables the oversampling factor to be freely configured. If the oversampling factor of the terminal is changed, then the PLC must be adapted to it. The settings described below are made in the global variable list (see fig. *Global Variable List*):

- The constant global variable *CnMaxOvs* corresponds to the selected oversampling factor.
- The constant global variable *CnUpperSampleArray* corresponds to $CnMaxOvs - 1$.
- Furthermore, the size of the FIFO buffer must be specified (see description of the function of the example program). The size is specified by the constant global variable *CnSizeOfFIFOBuffer*
- The constant global variable *CnUpperFIFOBufferArray* is $CnSizeOfFIFOBuffer - 1$.
- The variable *CnMaxRecordedValues* specifies the number of values that are used for the floating average calculation of the RMS values. The smallest possible value is 1
- The global variable *bValuesZeroWhenDataInvalid* specifies whether the FIFO buffer is to be filled with zeros in case of invalid data. In case of invalid data no more calculations take place for the channel concerned in any case. Filling the FIFO buffer with zeros may make it easier to find the source of the error.

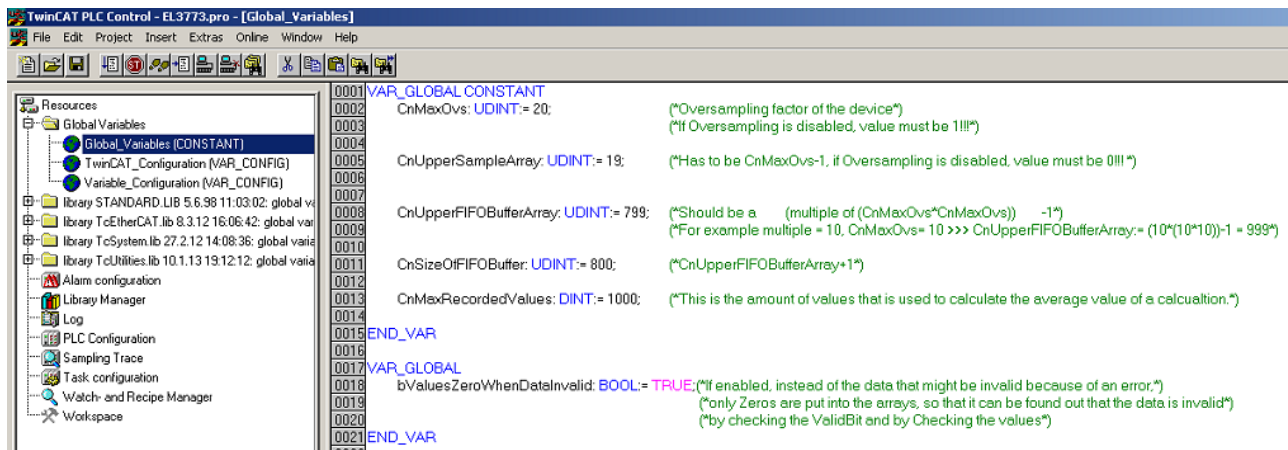

Fig. 155: Global Variable List

Adaptation of the calculation of voltage and current from the raw data

The program allows the adaptation of the conversion of the raw data into the corresponding voltage and current values. The default settings are already adapted to the EL3773 and do not absolutely have to be changed for commissioning.

Only the transformation factor of the current transformer should be checked.

- All necessary settings for the calculation of the respective voltage and current values are made in the MAIN. The presets correspond to the standard settings of the EL 3773
 - rMaxVoltage specifies the maximum measuring voltage
 - rMaxCurrent specifies the maximum measuring current
 - iMaxRawValue specifies the raw value of the terminal at the maximum measuring voltage.
 - The three variables *rTransformerFactor* specify the transformation factors of the current transformers for the respective current channels
 - Furthermore, offsets can be specified per channel. The inclusion of the offsets in the calculation of the measured values takes place directly by means of adaptation of the respective raw value.

6.11.3 Description of the function of the example program

Visualization

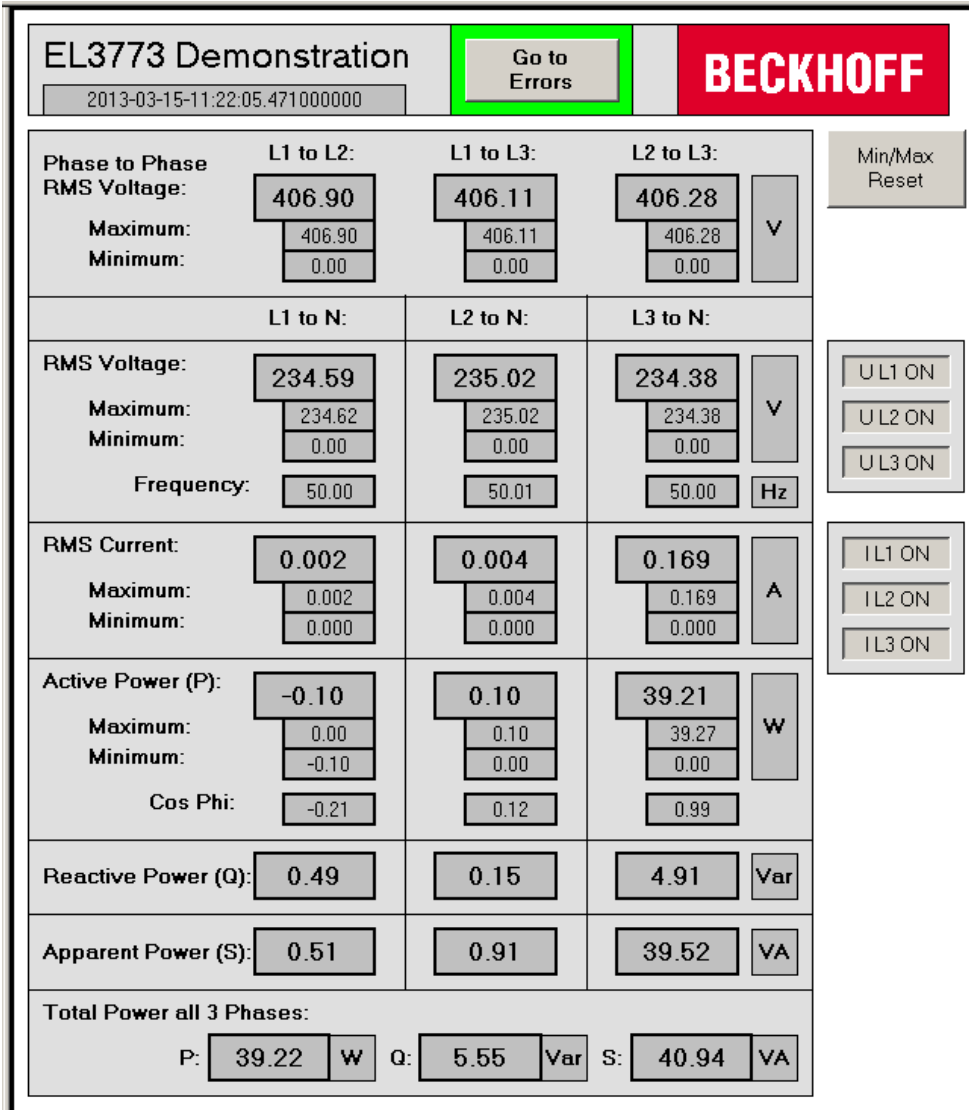

Fig. 156: First page of the visualization of the example program

The visualization consists of two pages. On the main page (see fig. *First page of the visualization of the example program*) all calculated values are displayed and the calculations for the channels can be switched on and off individually. Actuating the button labelled with "Go to Errors" opens the second page of the visualization, on which the errors that have occurred are displayed. Note that you can already see on the first page whether an error has occurred, because in this case there is a border around the aforementioned button (see fig. *Border around the "Go to Errors" button if errors have occurred*).

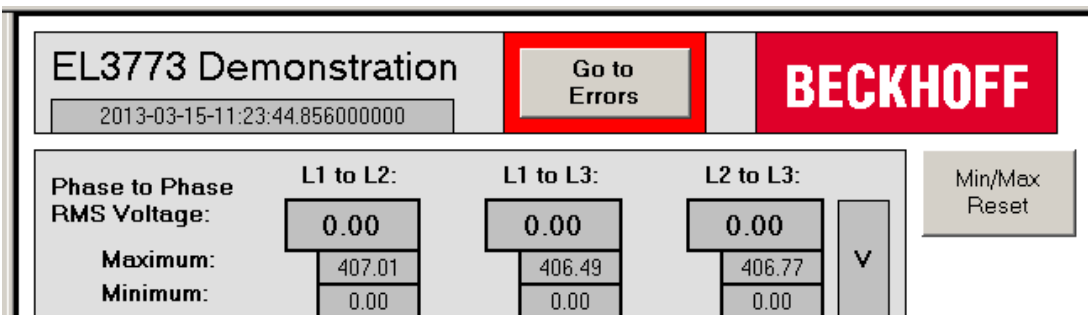

Fig. 157: Border around the "Go to Errors" button if errors have occurred

Errors that have occurred are displayed on the second page of the visualization (see fig. *Second page of the visualization of the EL3773 example program*). In this case, for example, the EtherCAT cable from the controller to the coupler was removed during operation.

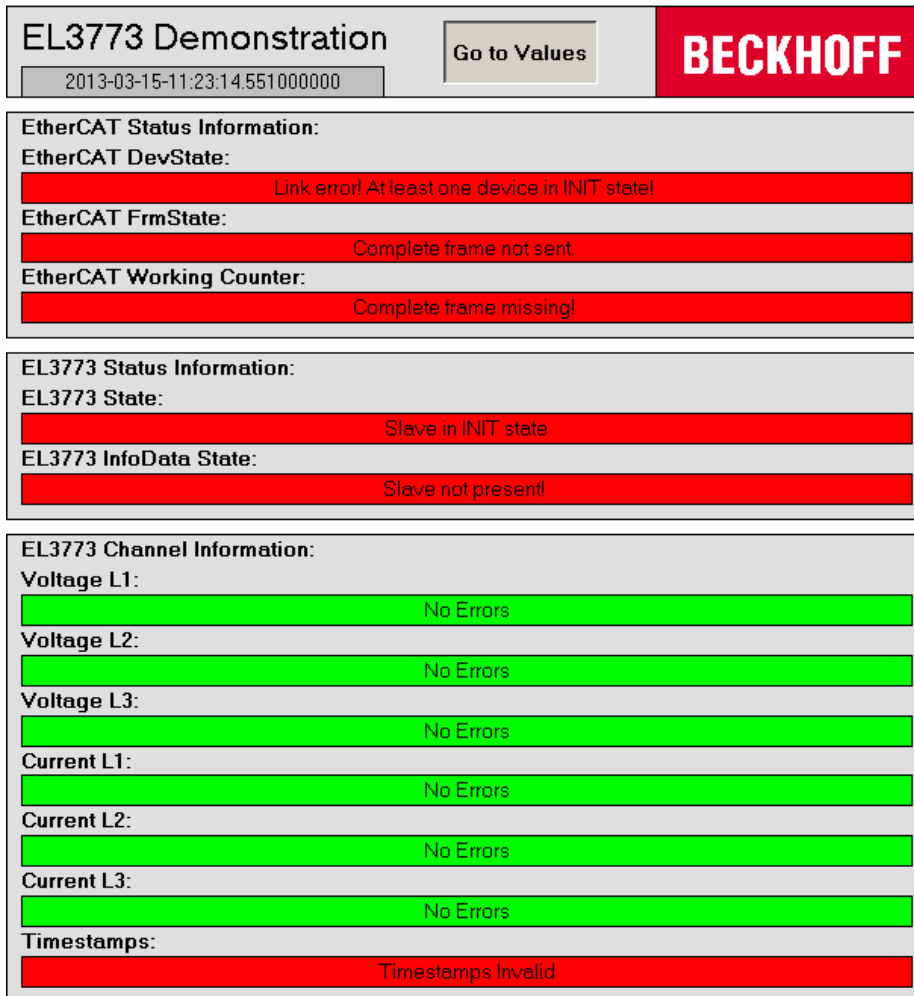

Fig. 158: Second page of the visualization of the EL3773 example program

Selection of the size of the FIFO buffer

The recorded samples are copied per cycle into a FIFO buffer in which the newest values are saved "at the front" and the oldest values are discarded "at the rear". The size of the FIFO buffer can be specified at the beginning and should be selected according to the oversampling factor, the cycle time and the connected frequency. Important for an accurate evaluation of the connected voltages and currents is a sufficiently large memory of recorded values. If the connected frequency is, for example, 50 Hz, then 4 values will be recorded per PLC cycle with an oversampling factor of 20 and a cycle time of 5 ms. The period at a frequency of 50 Hz is 20 ms and with the selected settings an entire period is sampled with 80 values. Hence, the size of the FIFO buffer should be an integral multiple of 80, for example 800.

The following illustration provides an overview of the principle of operation of the data buffer:

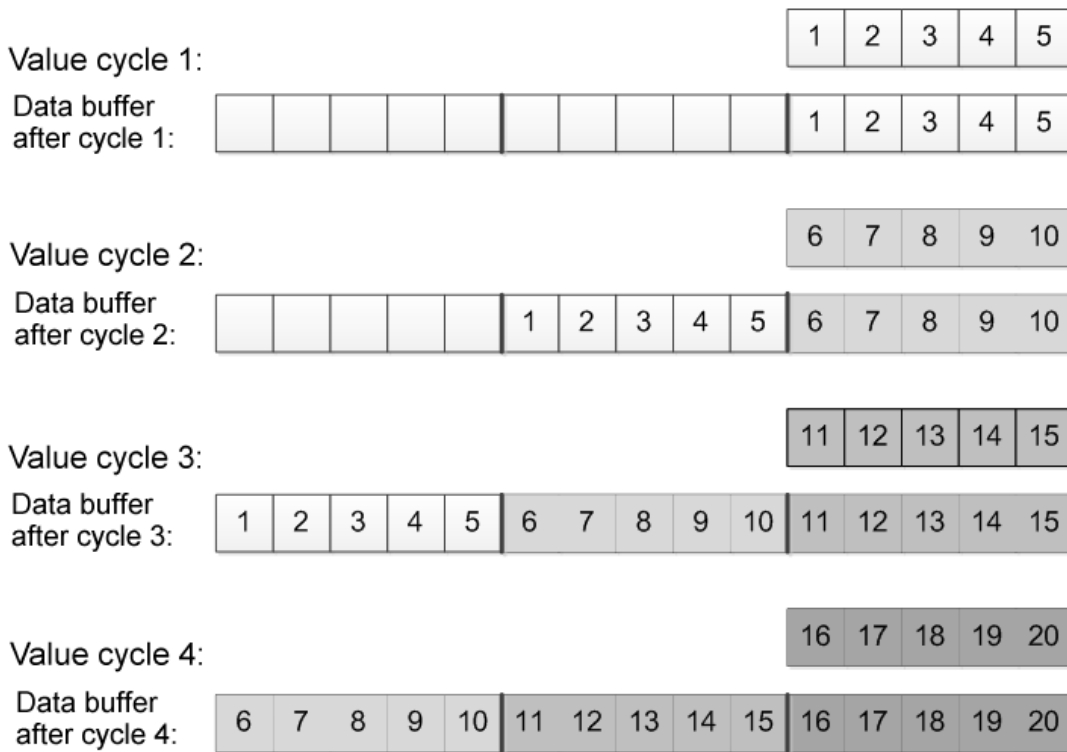

Fig. 159: Principle of operation of the data buffer

Performance of the calculations

Unless stated otherwise, all calculations are performed as sliding calculations with all of the calculated values in the FIFO buffer. Beyond that it has proven better in practice to form an average from the last calculated values. The number of values for this can be specified by the user with the global variable *CnMaxRecordedValues*.

Example: The general equation for the calculation of the RMS value is

$$u_{rms} = \sqrt{\frac{1}{n} \sum_1^n u(t)^2}$$

The respective lower and upper limits for the summation are specified by the size of the FIFO buffer. The RMS values are calculated by means of a sliding calculation of the entire size of the FIFO buffer in each cycle.

The result of the calculation is written in turn to a FIFO buffer, which is used to calculate the value displayed in the visualization by means of a sliding calculation:

$$u_{rms,average} = \frac{1}{n} \sum_1^n u_{rms}$$

The range for the summation is specified by the user via the global variable *CnMaxRecordedValues*.

	Calculation	Calculation of the value shown in the visu
RMS phase conductors	$u_{pp} = \sqrt{\frac{1}{n} \sum_1^n (u1(t) - u2(t))^2}$	$u_{pp,avg} = \frac{1}{n} \sum_1^n u_{pp}$
RMS phase	$u_{rms} = \sqrt{\frac{1}{n} \sum_1^n u(t)^2}$	$u_{rms,avg} = \frac{1}{n} \sum_1^n u_{rms}$
P	$P = \frac{1}{n} \sum_1^n u(t) * i(t)$	$P_{avg} = \frac{1}{n} \sum_1^n P(t)$
S	$S = u_{rms} * i_{rms}$	$S_{avg} = \frac{1}{n} \sum_1^n S(t)$
Q	$Q = \sqrt{S^2 - P^2}$	$Q_{avg} = \frac{1}{n} \sum_1^n Q(t)$
Cos Phi	$\cos \varphi = \frac{P}{S}$	see left

Fig. 160: Overview of the performance of the calculations

 Note	<p>Calculation of the frequency and the sign of the reactive power Q</p> <p>The frequency is calculated by determining the zero point of the zero crossing from positive to negative. This time is constantly determined and compared with the previous zero crossing.</p> <p>The frequency is calculated from the time difference. The method used for frequency calculation serves only as a starting point for the determination of a possible algorithm. It is up to the user to check the practical suitability of the method for a certain application. Practical tests have shown that the frequency calculation of a very noisy signal with the method used will not supply any reliable values. However, the calculation of the frequency of the 50 Hz mains voltage worked reliably in the tests performed.</p> <p>The same applies to the determination of the sign of the reactive power Q, because this is determined by comparing the times of the zero crossings of the voltage and current.</p>
--	--

6.11.4 Starting the example program

The application examples have been tested with a test configuration and are described accordingly. The program serves as an initial introduction to the options for evaluating the data from a mains monitoring terminal. The user is free to change the program to suit his ideas or to use only part of the code.

- The following hardware and software were used for the test configuration:
TwinCAT Master PC with Windows XP Professional SP 3 as operating system, TwinCAT version 2.11 (Build 2230) and Intel PCI Ethernet adapter
- Beckhoff EK1100 EtherCAT coupler, EL3773 and EL9011 terminals

Procedure for starting the program

- After clicking the Download button, save the zip file locally on your hard disk, and unzip the *.TSM (configuration) and the *.PRO (PLC program) files into a temporary working folder
- Run the *.TSM file and the *.PRO file; the TwinCAT System Manager and TwinCAT PLC will open
- Connect the hardware and connect the Ethernet adapter of your PC to the EtherCAT coupler (further information on this can be found in the corresponding coupler manuals)
- Select the local Ethernet adapter (with real-time driver, if applicable) under System configuration, I/O configuration, I/O devices, Device (EtherCAT); then on the “Adapter” tab choose “Search...”, select the appropriate adapter and confirm (see Fig. *Searching the Ethernet adapter + Selection and confirmation of the Ethernet adapter*).

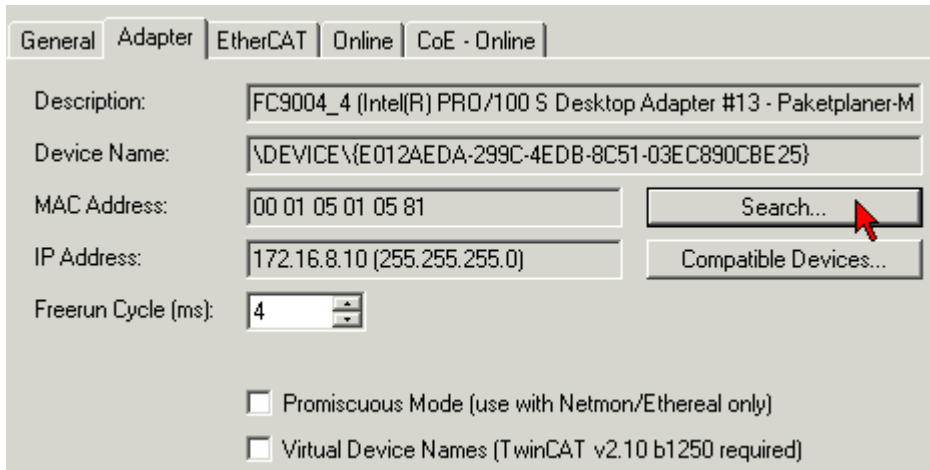

Fig. 161: Searching the Ethernet adapter

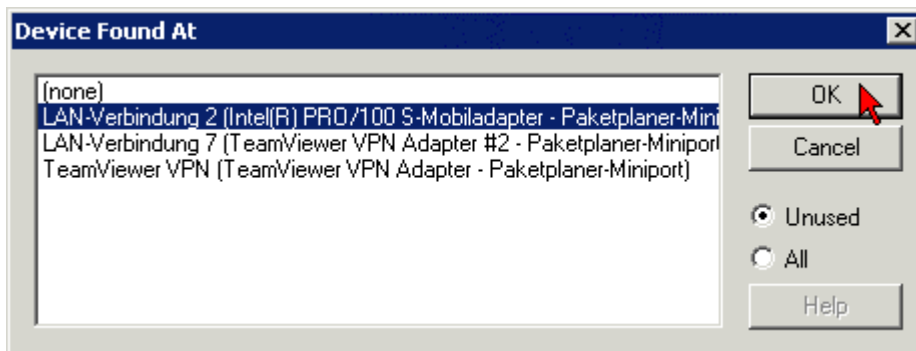

Fig. 162: Selection and confirmation of the Ethernet adapter

- Activate and confirm the configuration (Fig. *Activation of the configuration + Confirming the activation of the configuration*)



Fig. 163: Activation of the configuration

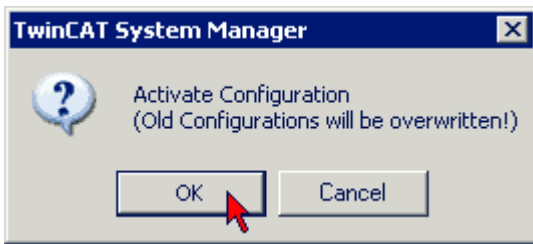

Fig. 164: Confirming the activation of the configuration

- Confirm new variable mapping, restart in RUN mode (Fig. *Generate variable mapping + Restarting TwinCAT in RUN mode*)

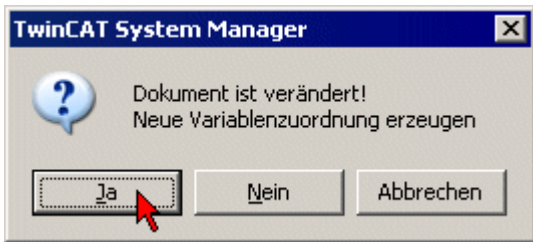

Fig. 165: Generating variable mapping

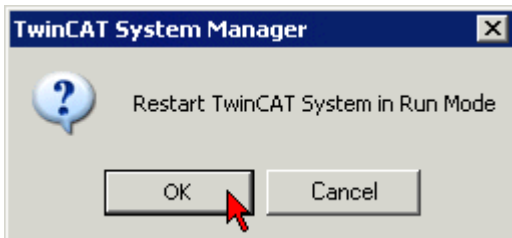

Fig. 166: Restarting TwinCAT in RUN mode

- In TwinCAT PLC, under the “Project” menu, select “Rebuild all” to compile the project (Fig. *Compile project*)

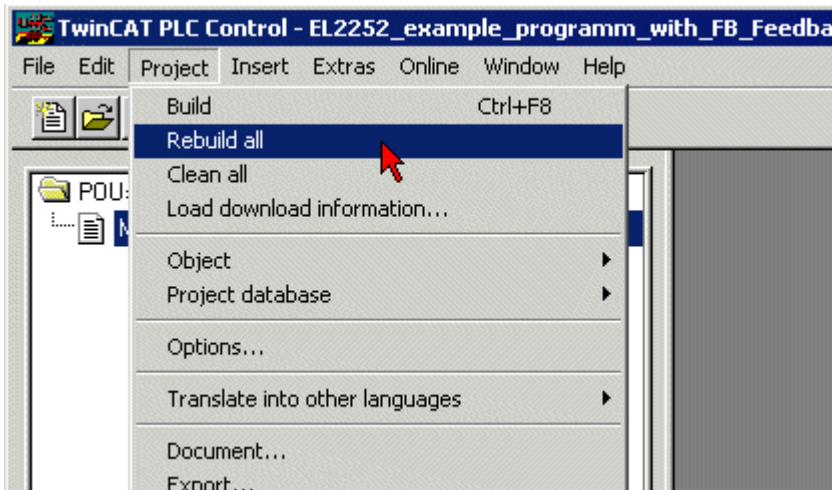

Fig. 167: Compile project

- In TwinCAT PLC: log in with the “F11” button, confirm loading the program (Fig. *Confirming program start*), run the program with the “F5” button

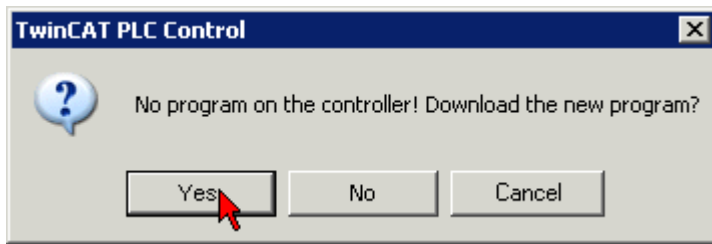

Fig. 168: Confirming program start

7 Diagnosis

7.1 Diagnostic methods

The EL3773 offers two methods of diagnosis:

- **Process data**
Some diagnostic details are given in the status word of the process data, see [Process data \[▶ 86\]](#).
- **Diag Messages**
Diag Messages can be read at any time from the CoE object [0x10F3 \[▶ 97\]](#).

System Manager Logger Output

Explanation of some typical EL3773 logger messages:



Fig. 169: EL3773 logger messages

- Parameter written too high, 0x06090031
CoE parameter is too large; the firmware limits the values to be written
- Parameter written too low, 0x06090032
CoE parameter is too small; the firmware limits the values to be written
- Data can not be transferred or stored to the application because of the present device state, 0x08000022
No supply voltage, terminal partly out of service

Diag Messages

Diag Messages designates a system for the transmission of messages from the EtherCAT Slave to the EtherCAT Master/TwinCAT. The messages are stored by the device in its own CoE under [0x10F3 \[▶ 97\]](#) and can be read by the application or the System Manager. An error message referenced via a code is output for each event stored in the device (warning, error, status change).

See the [Diag Messages notes \[▶ 150\]](#) regarding this.

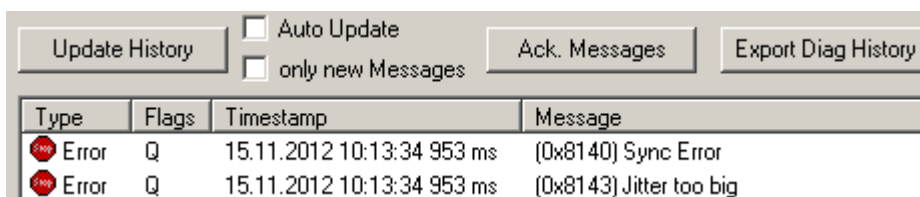

Fig. 170: EL3773 Diag Messages

7.2 Diagnostic LEDs

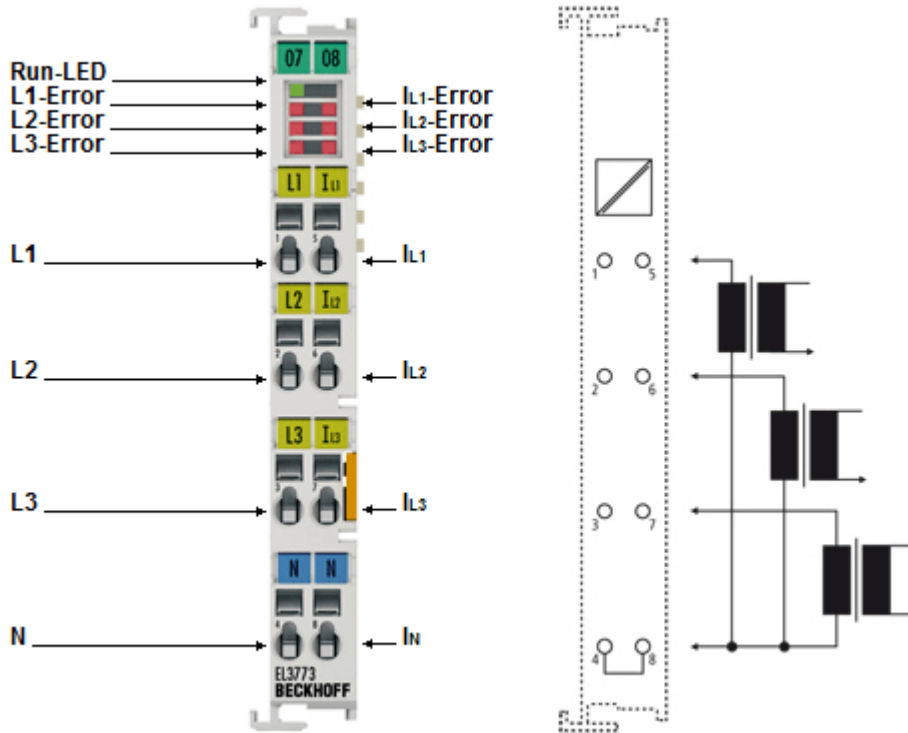

Fig. 171: EL3773

LED	Color	Meaning	
Run	green	This LED indicates the terminal's operating state.	
		off	State of the EtherCAT State Machine: INIT = terminal initialization
		flashing	State of the EtherCAT State Machine: PREOP = function of mailbox communication and variant standard settings
		single flash	State of the EtherCAT State Machine: SAFEOP = verification of the sync manager channels and the distributed clocks. Outputs remain in safe state.
		on	State of the EtherCAT State Machine: OP = normal operating state; mailbox-and process data communication is possible
L1-L3 Error	red	off	No measuring error in the voltage circuit
		on	Measuring range exceeded in the voltage circuit
I _{L1} - I _{L3} Error	red	off	No measuring error in the current circuit
		on	Measuring range exceeded in the current circuit

7.3 Diagnostics – basic principles of diag messages

DiagMessages designates a system for the transmission of messages from the EtherCAT Slave to the EtherCAT Master/TwinCAT. The messages are stored by the device in its own CoE under 0x10F3 and can be read by the application or the System Manager. An error message referenced via a code is output for each event stored in the device (warning, error, status change).

Definition

The *DiagMessages* system is defined in the ETG (EtherCAT Technology Group) in the guideline ETG.1020, chapter 13 “Diagnosis handling”. It is used so that pre-defined or flexible diagnostic messages can be conveyed from the EtherCAT Slave to the Master. In accordance with the ETG, the process can therefore be implemented supplier-independently. Support is optional. The firmware can store up to 250 *DiagMessages* in its own CoE.

Each *DiagMessage* consists of

- Diag Code (4-byte)
- Flags (2-byte; info, warning or error)
- Text ID (2-byte; reference to explanatory text from the ESI/XML)
- Timestamp (8-byte, local slave time or 64-bit Distributed Clock time, if available)
- Dynamic parameters added by the firmware

The *DiagMessages* are explained in text form in the ESI/XML file belonging to the EtherCAT device: on the basis of the Text ID contained in the *DiagMessage*, the corresponding plain text message can be found in the languages contained in the ESI/XML. In the case of Beckhoff products these are usually German and English.

Via the entry *NewMessagesAvailable* the user receives information that new messages are available.

DiagMessages can be confirmed in the device: the last/latest unconfirmed message can be confirmed by the user.

In the CoE both the control entries and the history itself can be found in the CoE object 0x10F3:

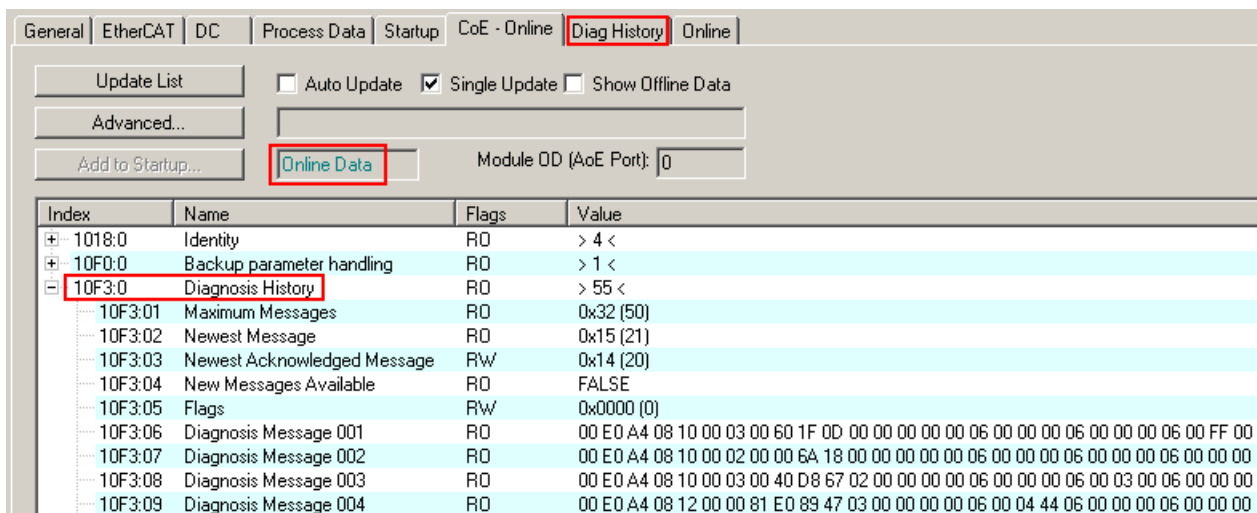



Fig. 172: *DiagMessages* in the CoE

The subindex of the latest *DiagMessage* can be read under x10F3:02.

 Note	<p>Support for commissioning</p> <p>The <i>DiagMessages</i> system is to be used above all during the commissioning of the plant. The diagnostic values e.g. in the StatusWord of the device (if available) are helpful for on-line diagnosis during the subsequent continuous operation.</p>
--	--

TwinCAT System Manager implementation

From TwinCAT 2.11 DiagMessages, if available, are displayed in the device's own interface. Operation (collection, confirmation) also takes place via this interface.

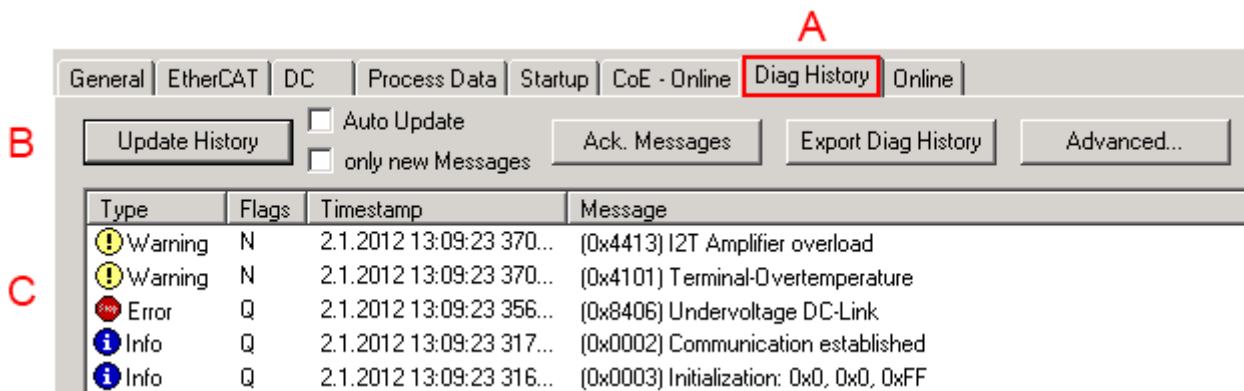

Fig. 173: Implementation of the DiagMessage system in the TwinCAT System Manager

The operating buttons (B) and the history read out (C) can be seen on the Diag History tab (A). The components of the message:

- Info/Warning/Error
- Acknowledge flag (N = unconfirmed, Q = confirmed)
- Time stamp
- Text ID
- Plain text message according to ESI/XML data

The meanings of the buttons are self-explanatory.

DiagMessages within the ADS Logger/Eventlogger

Since TwinCAT 3.1 build 4022 DiagMessages send by the terminal are shown by the TwinCAT ADS Logger. Given that DiagMessages are represented IO- comprehensive at one place, commissioning will be simplified. In addition, the logger output could be stored into a data file – hence DiagMessages are available long-term for analysis.

Reading messages into the PLC

- In preparation -

Interpretation

Time stamp

The time stamp is obtained from the local clock of the terminal at the time of the event. The time is usually the distributed clock time (DC) from register x910.

Please note: When EtherCAT is started, the DC time in the reference clock is set to the same time as the local IPC/TwinCAT time. From this moment the DC time may differ from the IPC time, since the IPC time is not adjusted. Significant time differences may develop after several weeks of operation without a EtherCAT restart. As a remedy, external synchronization of the DC time can be used, or a manual correction calculation can be applied, as required: The current DC time can be determined via the EtherCAT master or from register x901 of the DC slave.

Structure of the Text ID

The structure of the MessageID is not subject to any standardization and can be supplier-specifically defined. In the case of Beckhoff EtherCAT devices (EL, EP) it usually reads according to **xyzz**:

x	y	zz
0: Systeminfo 2: reserved 1: Info 4: Warning 8: Error	0: System 1: General 2: Communication 3: Encoder 4: Drive 5: Inputs 6: I/O general 7: reserved	Error number

Example: Message 0x4413 --> Drive Warning Number 0x13

Overview of text IDs

Specific Text IDs should be specified in the device documentation.

Text ID	Type	Place	Text Message	Additional comment
0x0001	Information	System	No error	No error
0x0002	Information	System	Communication established	Connection established
0x0003	Information	System	Initialization: 0x%X, 0x%X, 0x%X	General information; parameters depend on event. See device documentation for interpretation.
0x1000	Information	System	Information: 0x%X, 0x%X, 0x%X	General information; parameters depend on event. See device documentation for interpretation.
0x1012	Information	System	EtherCAT state change Init - PreOp	
0x1021	Information	System	EtherCAT state change PreOp - Init	
0x1024	Information	System	EtherCAT state change PreOp - Safe-Op	
0x1042	Information	System	EtherCAT state change SafeOp - PreOp	
0x1048	Information	System	EtherCAT state change SafeOp - Op	
0x1084	Information	System	EtherCAT state change Op - SafeOp	
0x1100	Information	General	Detection of operation mode completed: 0x%X, %d	Detection of the mode of operation ended
0x1135	Information	General	Cycle time o.k.: %d	Cycle time OK
0x1157	Information	General	Data manually saved (Idx: 0x%X, SubIdx: 0x%X)	Data saved manually
0x1158	Information	General	Data automatically saved (Idx: 0x%X, SubIdx: 0x%X)	Data saved automatically
0x1159	Information	General	Data deleted (Idx: 0x%X, SubIdx: 0x%X)	Data deleted
0x117F	Information	General	Information: 0x%X, 0x%X, 0x%X	Information
0x1201	Information	Communication	Communication re-established	Communication to the field side restored This message appears, for example, if the voltage was removed from the power contacts and re-applied during operation
0x1300	Information	Encoder	Position set: %d, %d	Position set - StartInputhandler
0x1303	Information	Encoder	Encoder Supply ok	Encoder power supply unit OK
0x1304	Information	Encoder	Encoder initialization successfully, channel: %X	Encoder initialization successfully completed
0x1305	Information	Encoder	Sent command encoder reset, channel: %X	Send encoder reset command
0x1400	Information	Drive	Drive is calibrated: %d, %d	Drive is calibrated
0x1401	Information	Drive	Actual drive state: 0x%X, %d	Current drive status
0x1705	Information		CPU usage returns in normal range (< 85%%)	Processor load is back in the normal range
0x1706	Information		Channel is not in saturation anymore	Channel is no longer in saturation
0x1707	Information		Channel is not in overload anymore	Channel is no longer overloaded
0x170A	Information		No channel range error anymore	A measuring range error is no longer active
0x170C	Information		Calibration data saved	Calibration data were saved
0x170D	Information		Calibration data will be applied and saved after sending the command "0x5AFE"	Calibration data are not applied and saved until the command "0x5AFE" is sent

Text ID	Type	Place	Text Message	Additional comment
0x2000	Information	System	%s: %s	
0x2001	Information	System	%s: Network link lost	Network connection lost
0x2002	Information	System	%s: Network link detected	Network connection found
0x2003	Information	System	%s: no valid IP Configuration - Dhcp client started	Invalid IP configuration
0x2004	Information	System	%s: valid IP Configuration (IP: %d.%d.%d.%d) assigned by Dhcp server %d.%d.%d.%d	Valid IP configuration, assigned by the DHCP server
0x2005	Information	System	%s: Dhcp client timed out	DHCP client timeout
0x2006	Information	System	%s: Duplicate IP Address detected (%d.%d.%d.%d)	Duplicate IP address found
0x2007	Information	System	%s: UDP handler initialized	UDP handler initialized
0x2008	Information	System	%s: TCP handler initialized	TCP handler initialized
0x2009	Information	System	%s: No more free TCP sockets available	No free TCP sockets available.

Text ID	Type	Place	Text Message	Additional comment
0x4000	Warning		Warning: 0x%X, 0x%X, 0x%X	General warning; parameters depend on event. See device documentation for interpretation.
0x4001	Warning	System	Warning: 0x%X, 0x%X, 0x%X	
0x4002	Warning	System	%s: %s Connection Open (IN:%d OUT:%d API:%dms) from %d.%d.%d.%d successful	
0x4003	Warning	System	%s: %s Connection Close (IN:%d OUT:%d) from %d.%d.%d.%d successful	
0x4004	Warning	System	%s: %s Connection (IN: %d OUT:%d) with %d.%d.%d timed out	
0x4005	Warning	System	%s: %s Connection Open (IN:%d OUT:%d) from %d.%d.%d.%d denied (Error: %u)	
0x4006	Warning	System	%s: %s Connection Open (IN:%d OUT:%d) from %d.%d.%d.%d denied (Input Data Size expected: %d Byte(s) received: %d Byte(s))	
0x4007	Warning	System	%s: %s Connection Open (IN:%d OUT:%d) from %d.%d.%d.%d denied (Output Data Size expected: %d Byte(s) received: %d Byte(s))	
0x4008	Warning	System	%s: %s Connection Open (IN:%d OUT:%d) from %d.%d.%d.%d denied (RPI:%dms not supported -> API:%dms)	
0x4101	Warning	General	Terminal-Overtemperature	Overtemperature. The internal temperature of the terminal exceeds the parameterized warning threshold
0x4102	Warning	General	Discrepancy in the PDO-Configuration	The selected PDOs do not match the set operating mode. Sample: Drive operates in velocity mode, but the velocity PDO is but not mapped in the PDOs.
0x417F	Warning	General	Warning: 0x%X, 0x%X, 0x%X	
0x428D	Warning	General	Challenge is not Random	
0x4300	Warning	Encoder	Subincrements deactivated: %d, %d	Sub-increments deactivated (despite activated configuration)
0x4301	Warning	Encoder	Encoder-Warning	General encoder error
0x4400	Warning	Drive	Drive is not calibrated: %d, %d	Drive is not calibrated
0x4401	Warning	Drive	Starttype not supported: 0x%X, %d	Start type is not supported
0x4402	Warning	Drive	Command rejected: %d, %d	Command rejected
0x4405	Warning	Drive	Invalid modulo subtype: %d, %d	Modulo sub-type invalid
0x4410	Warning	Drive	Target overrun: %d, %d	Target position exceeded
0x4411	Warning	Drive	DC-Link undervoltage (Warning)	The DC link voltage of the terminal is lower than the parameterized minimum voltage. Activation of the output stage is prevented
0x4412	Warning	Drive	DC-Link overvoltage (Warning)	The DC link voltage of the terminal is higher than the parameterized maximum voltage. Activation of the output stage is prevented
0x4413	Warning	Drive	I2T-Model Amplifier overload (Warning)	- The amplifier is being operated outside the specification - The I2T-model of the amplifier is incorrectly parameterized

Text ID	Type	Place	Text Message	Additional comment
0x4414	Warning	Drive	I2T-Model Motor over-load (Warning)	- The motor is being operated outside the parameterized rated values - The I2T-model of the motor is incorrectly parameterized
0x4415	Warning	Drive	Speed limitation active	The maximum speed is limited by the parameterized objects (e.g. velocity limitation, motor speed limitation). This warning is output if the set velocity is higher than one of the parameterized limits
0x4416	Warning	Drive	Step lost detected at position: 0x%X%X	Step loss detected
0x4417	Warning	Drive	Motor overtemperature	The internal temperature of the motor exceeds the parameterized warning threshold
0x4418	Warning	Drive	Limit: Current	Limit: current is limited
0x4419	Warning	Drive	Limit: Amplifier I2T-model exceeds 100%%	The threshold values for the maximum current were exceeded.
0x441A	Warning	Drive	Limit: Motor I2T-model exceeds 100%%	Limit: Motor I2T-model exceeds 100%
0x441B	Warning	Drive	Limit: Velocity limitation	The threshold values for the maximum speed were exceeded.
0x441C	Warning	Drive	STO while the axis was enabled	An attempt was made to activate the axis, despite the fact that no voltage is present at the STO input.
0x4600	Warning	General IO	Wrong supply voltage range	Supply voltage not in the correct range
0x4610	Warning	General IO	Wrong output voltage range	Output voltage not in the correct range
0x4705	Warning		Processor usage at %d %%	Processor load at %d %%
0x470A	Warning		EtherCAT Frame missed (change Settings or DC Operation Mode or Sync0 Shift Time)	EtherCAT frame missed (change DC Operation Mode or Sync0 Shift Time under Settings)



Text ID	Type	Place	Text Message	Additional comment
0x8000	Error	System	%s: %s	
0x8001	Error	System	Error: 0x%X, 0x%X, 0x%X	General error; parameters depend on event. See device documentation for interpretation.
0x8002	Error	System	Communication aborted	Communication aborted
0x8003	Error	System	Configuration error: 0x%X, 0x%X, 0x%X	General; parameters depend on event. See device documentation for interpretation.
0x8004	Error	System	%s: Unsuccessful FwdOpen-Response received from %d.%d.%d.%d (%s) (Error: %u)	
0x8005	Error	System	%s: FwdClose-Request sent to %d.%d.%d.%d (%s)	
0x8006	Error	System	%s: Unsuccessful FwdClose-Response received from %d.%d.%d.%d (%s) (Error: %u)	
0x8007	Error	System	%s: Connection with %d.%d.%d.%d (%s) closed	
0x8100	Error	General	Status word set: 0x%X, %d	Error bit set in the status word
0x8101	Error	General	Operation mode incompatible to PDO interface: 0x%X, %d	Mode of operation incompatible with the PDO interface
0x8102	Error	General	Invalid combination of Inputs and Outputs PDOs	Invalid combination of input and output PDOs
0x8103	Error	General	No variable linkage	No variables linked
0x8104	Error	General	Terminal-Overtemperature	The internal temperature of the terminal exceeds the parameterized error threshold. Activation of the terminal is prevented
0x8105	Error	General	PD-Watchdog	Communication between the fieldbus and the output stage is secured by a Watchdog. The axis is stopped automatically if the fieldbus communication is interrupted. - The EtherCAT connection was interrupted during operation - The Master was switched to Config mode during operation
0x8135	Error	General	Cycle time has to be a multiple of 125 µs	The IO or NC cycle time divided by 125 µs does not produce a whole number
0x8136	Error	General	Configuration error: invalid sampling rate	Configuration error: Invalid sampling rate
0x8137	Error	General	Electronic type plate: CRC error	Content of the external name plate memory invalid.
0x8140	Error	General	Sync Error	Real-time violation
0x8141	Error	General	Sync%X Interrupt lost	Sync%X Interrupt lost
0x8142	Error	General	Sync Interrupt asynchronous	Sync Interrupt asynchronous
0x8143	Error	General	Jitter too big	Jitter limit violation
0x817F	Error	General	Error: 0x%X, 0x%X, 0x%X	
0x8200	Error	Communication	Write access error: %d, %d	Error while writing
0x8201	Error	Communication	No communication to field-side (Auxiliary voltage missing)	- There is no voltage applied to the power contacts - A firmware update has failed
0x8281	Error	Communication	Ownership failed: %X	
0x8282	Error	Communication	To many Keys founded	
0x8283	Error	Communication	Key Creation failed: %X	
0x8284	Error	Communication	Key loading failed	
0x8285	Error	Communication	Reading Public Key failed: %X	
0x8286	Error	Communication	Reading Public EK failed: %X	
0x8287	Error	Communication	Reading PCR Value failed: %X	

Text ID	Type	Place	Text Message	Additional comment
0x8288	Error	Communication	Reading Certificate EK failed: %X	
0x8289	Error	Communication	Challenge could not be hashed: %X	
0x828A	Error	Communication	Tickstamp Process failed	
0x828B	Error	Communication	PCR Process failed: %X	
0x828C	Error	Communication	Quote Process failed: %X	
0x82FF	Error	Communication	Bootmode not activated	Boot mode not activated
0x8300	Error	Encoder	Set position error: 0x%X, %d	Error while setting the position
0x8301	Error	Encoder	Encoder increments not configured: 0x%X, %d	Encoder increments not configured
0x8302	Error	Encoder	Encoder error	The amplitude of the resolver is too small
0x8303	Error	Encoder	Encoder supply error	Encoder power supply unit error
0x8304	Error	Encoder	Encoder communication error, channel: %X	Encoder communication error
0x8305	Error	Encoder	EnDat2.2 is not supported, channel: %X	EnDat2.2 is not supported
0x8306	Error	Encoder	Delay time, tolerance limit exceeded, 0x%X, channel: %X	Runtime measurement, tolerance exceeded
0x8307	Error	Encoder	Delay time, maximum value exceeded, 0x%X, channel: %X	Runtime measurement, maximum value exceeded
0x8308	Error	Encoder	Unsupported ordering designation, 0x%X, channel: %X (only 02 and 22 is supported)	Wrong EnDat order ID
0x8309	Error	Encoder	Encoder CRC error, channel: %X	Encoder CRC error
0x830A	Error	Encoder	Temperature %X could not be read, channel: %X	Temperature cannot be read
0x8400	Error	Drive	Incorrect drive configuration: 0x%X, %d	Drive incorrectly configured
0x8401	Error	Drive	Limiting of calibration velocity: %d, %d	Limitation of the calibration velocity
0x8402	Error	Drive	Emergency stop activated: 0x%X, %d	Emergency stop activated
0x8403	Error	Drive	ADC Error	Error during current measurement in the ADC
0x8404	Error	Drive	Overcurrent	Overcurrent in phase U, V or W
0x8405	Error	Drive	Invalid modulo position: %d	Modulo position invalid
0x8406	Error	Drive	DC-Link undervoltage (Error)	The DC link voltage of the terminal is lower than the parameterized minimum voltage. Activation of the output stage is prevented
0x8407	Error	Drive	DC-Link overvoltage (Error)	The DC link voltage of the terminal is higher than the parameterized maximum voltage. Activation of the output stage is prevented
0x8408	Error	Drive	I2T-Model Amplifier overload (Error)	- The amplifier is being operated outside the specification - The I2T-model of the amplifier is incorrectly parameterized
0x8409	Error	Drive	I2T-Model motor overload (Error)	- The motor is being operated outside the parameterized rated values - The I2T-model of the motor is incorrectly parameterized
0x840A	Error	Drive	Overall current threshold exceeded	Total current exceeded
0x8415	Error	Drive	Invalid modulo factor: %d	Modulo factor invalid
0x8416	Error	Drive	Motor overtemperature	The internal temperature of the motor exceeds the parameterized error threshold. The motor stops immediately. Activation of the output stage is prevented.
0x8417	Error	Drive	Maximum rotating field velocity exceeded	Rotary field speed exceeds the value specified for dual use (EU 1382/2014).

Text ID	Type	Place	Text Message	Additional comment
0x841C	Error	Drive	STO while the axis was enabled	An attempt was made to activate the axis, despite the fact that no voltage is present at the STO input.
0x8550	Error	Inputs	Zero crossing phase %X missing	Zero crossing phase %X missing
0x8551	Error	Inputs	Phase sequence Error	Wrong direction of rotation
0x8552	Error	Inputs	Overcurrent phase %X	Overcurrent phase %X
0x8553	Error	Inputs	Overcurrent neutral wire	Overcurrent neutral wire
0x8581	Error	Inputs	Wire broken Ch %D	Wire broken Ch %d
0x8600	Error	General IO	Wrong supply voltage range	Supply voltage not in the correct range
0x8601	Error	General IO	Supply voltage to low	Supply voltage too low
0x8602	Error	General IO	Supply voltage to high	Supply voltage too high
0x8603	Error	General IO	Over current of supply voltage	Overcurrent of supply voltage
0x8610	Error	General IO	Wrong output voltage range	Output voltage not in the correct range
0x8611	Error	General IO	Output voltage to low	Output voltage too low
0x8612	Error	General IO	Output voltage to high	Output voltage too high
0x8613	Error	General IO	Over current of output voltage	Overcurrent of output voltage
0x8700	Error		Channel/Interface not calibrated	Channel/interface not synchronized
0x8701	Error		Operating time was manipulated	Operating time was manipulated
0x8702	Error		Oversampling setting is not possible	Oversampling setting not possible
0x8703	Error		No slave controller found	No slave controller found
0x8704	Error		Slave controller is not in Bootstrap	Slave controller is not in bootstrap
0x8705	Error		Processor usage to high (>= 100%%)	Processor load too high (>= 100%%)
0x8706	Error		Channel in saturation	Channel in saturation
0x8707	Error		Channel overload	Channel overload
0x8708	Error		Overloadtime was manipulated	Overload time was manipulated
0x8709	Error		Saturationtime was manipulated	Saturation time was manipulated
0x870A	Error		Channel range error	Measuring range error for the channel
0x870B	Error		no ADC clock	No ADC clock available
0xFFFF	Information		Debug: 0x%X, 0x%X, 0x%X	Debug: 0x%X, 0x%X, 0x%X

8 Appendix

8.1 UL notice

	<p>Application Beckhoff EtherCAT modules are intended for use with Beckhoff's UL Listed EtherCAT System only.</p>
	<p>Examination For cULus examination, the Beckhoff I/O System has only been investigated for risk of fire and electrical shock (in accordance with UL508 and CSA C22.2 No. 142).</p>
	<p>For devices with Ethernet connectors Not for connection to telecommunication circuits.</p>

Basic principles

Two UL certificates are met in the Beckhoff EtherCAT product range, depending upon the components:

- UL certification according to UL508
Devices with this kind of certification are marked by this sign:



Almost all current EtherCAT products (as at 2010/05) are UL certified without restrictions.

- UL certification according to UL508 with limited power consumption
The current consumed by the device is limited to a max. possible current consumption of 4 A. Devices with this kind of certification are marked by this sign:

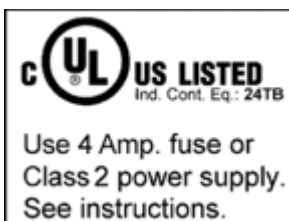

Almost all current EtherCAT products (as at 2010/05) are UL certified without restrictions.

Application

If terminals certified *with restrictions* are used, then the current consumption at 24 V_{DC} must be limited accordingly by means of supply

- from an isolated source protected by a fuse of max. 4A (according to UL248) or
- from a voltage supply complying with *NEC class 2*.
A voltage source complying with *NEC class 2* may not be connected in series or parallel with another *NEC class 2* compliant voltage supply!

These requirements apply to the supply of all EtherCAT bus couplers, power adaptor terminals, Bus Terminals and their power contacts.

8.2 Firmware Update EL/ES/EM/EPxxxx

This section describes the device update for Beckhoff EtherCAT slaves from the EL/ES, EM, EK and EP series. A firmware update should only be carried out after consultation with Beckhoff support.

Storage locations

An EtherCAT slave stores operating data in up to 3 locations:

- Depending on functionality and performance EtherCAT slaves have one or several local controllers for processing I/O data. The corresponding program is the so-called **firmware** in *.efw format.
- In some EtherCAT slaves the EtherCAT communication may also be integrated in these controllers. In this case the controller is usually a so-called **FPGA** chip with *.rbf firmware.
- In addition, each EtherCAT slave has a memory chip, a so-called **ESI-EEPROM**, for storing its own device description (ESI: EtherCAT Slave Information). On power-up this description is loaded and the EtherCAT communication is set up accordingly. The device description is available from the download area of the Beckhoff website at (<http://www.beckhoff.de>). All ESI files are accessible there as zip files.

Customers can access the data via the EtherCAT fieldbus and its communication mechanisms. Acyclic mailbox communication or register access to the ESC is used for updating or reading of these data.

The TwinCAT System Manager offers mechanisms for programming all 3 parts with new data, if the slave is set up for this purpose. Generally the slave does not check whether the new data are suitable, i.e. it may no longer be able to operate if the data are unsuitable.

Simplified update by bundle firmware

The update using so-called **bundle firmware** is more convenient: in this case the controller firmware and the ESI description are combined in a *.efw file; during the update both the firmware and the ESI are changed in the terminal. For this to happen it is necessary

- for the firmware to be in a packed format: recognizable by the file name, which also contains the revision number, e.g. ELxxx-xxx_REV0016_SW01.efw
- for password=1 to be entered in the download dialog. If password=0 (default setting) only the firmware update is carried out, without an ESI update.
- for the device to support this function. The function usually cannot be retrofitted; it is a component of many new developments from year of manufacture 2016.

Following the update, its success should be verified

- ESI/Revision: e.g. by means of an online scan in TwinCAT ConfigMode/FreeRun – this is a convenient way to determine the revision
- Firmware: e.g. by looking in the online CoE of the device

 Attention	<p>Risk of damage to the device!</p> <p>Note the following when downloading new device files</p> <ul style="list-style-type: none"> • Firmware downloads to an EtherCAT device must not be interrupted • Flawless EtherCAT communication must be ensured. CRC errors or LostFrames must be avoided. • The power supply must adequately dimensioned. The signal level must meet the specification. <p>In the event of malfunctions during the update process the EtherCAT device may become unusable and require re-commissioning by the manufacturer.</p>
---	---

8.2.1 Device description ESI file/XML



Attention

Attention regarding update of the ESI description/EEPROM

Some slaves have stored calibration and configuration data from the production in the EEPROM. These are irretrievably overwritten during an update.

The ESI device description is stored locally on the slave and loaded on start-up. Each device description has a unique identifier consisting of slave name (9 characters/digits) and a revision number (4 digits). Each slave configured in the System Manager shows its identifier in the EtherCAT tab:

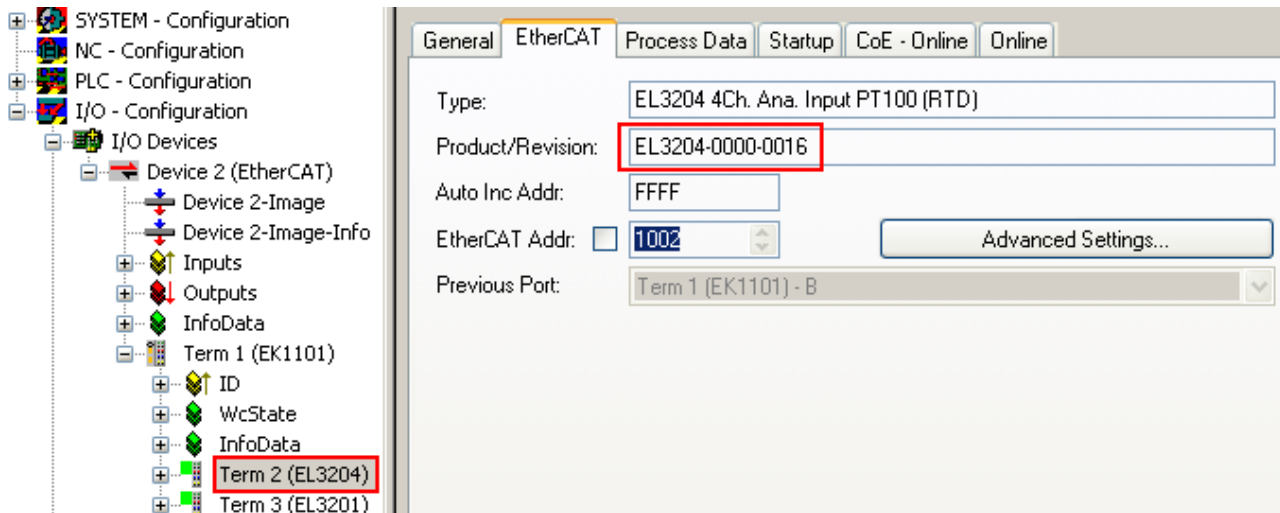

Fig. 174: Device identifier consisting of name EL3204-0000 and revision -0016

The configured identifier must be compatible with the actual device description used as hardware, i.e. the description which the slave has loaded on start-up (in this case EL3204). Normally the configured revision must be the same or lower than that actually present in the terminal network.

For further information on this, please refer to the [EtherCAT system documentation](#).



Note

Update of XML/ESI description

The device revision is closely linked to the firmware and hardware used. Incompatible combinations lead to malfunctions or even final shutdown of the device. Corresponding updates should only be carried out in consultation with Beckhoff support.

Display of ESI slave identifier

The simplest way to ascertain compliance of configured and actual device description is to scan the EtherCAT boxes in TwinCAT mode Config/FreeRun:

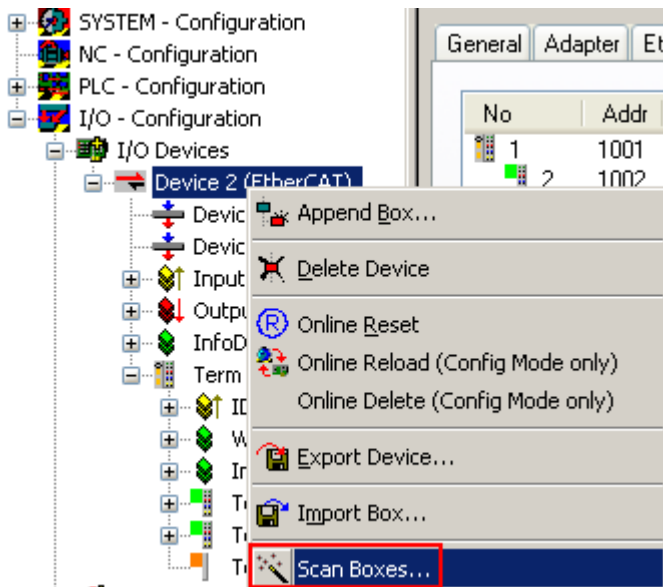

Fig. 175: Scan the subordinate field by right-clicking on the EtherCAT device

If the found field matches the configured field, the display shows



Fig. 176: Configuration is identical

otherwise a change dialog appears for entering the actual data in the configuration.

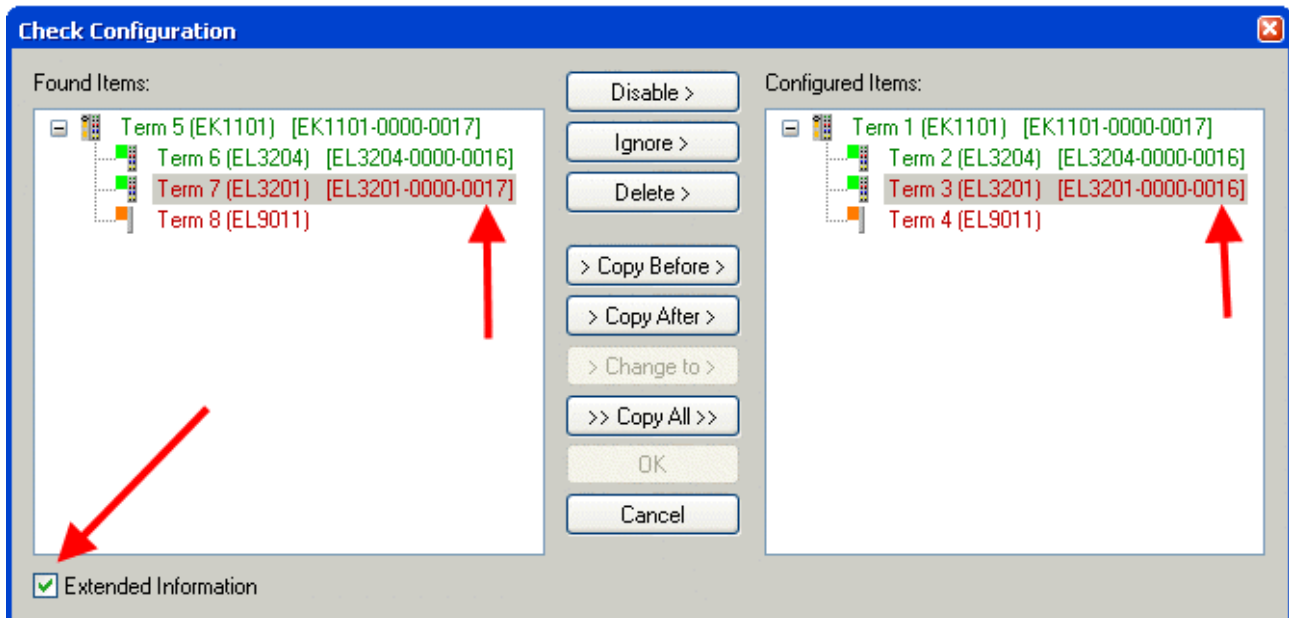

Fig. 177: Change dialog

In this example in Fig. *Change dialog*, an EL3201-0000-0017 was found, while an EL3201-0000-0016 was configured. In this case the configuration can be adapted with the *Copy Before* button. The *Extended Information* checkbox must be set in order to display the revision.

Changing the ESI slave identifier

The ESI/EEPROM identifier can be updated as follows under TwinCAT:

- Trouble-free EtherCAT communication must be established with the slave.
- The state of the slave is irrelevant.
- Right-clicking on the slave in the online display opens the *EEPROM Update* dialog, Fig. *EEPROM Update*

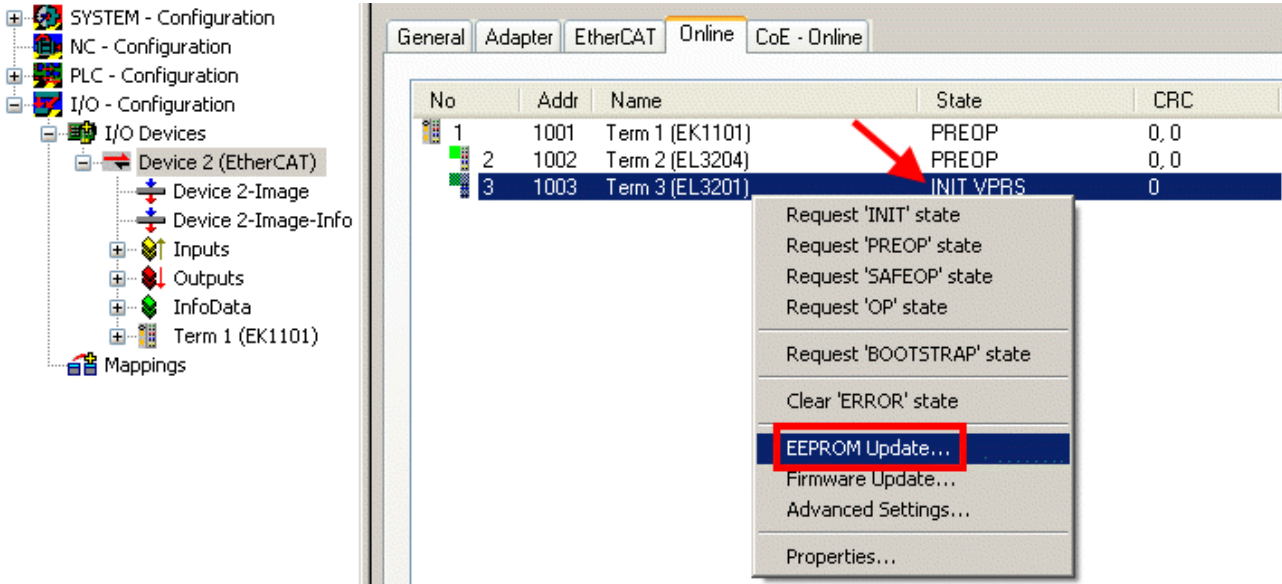

Fig. 178: EEPROM Update

The new ESI description is selected in the following dialog, see Fig. *Selecting the new ESI*. The checkbox *Show Hidden Devices* also displays older, normally hidden versions of a slave.

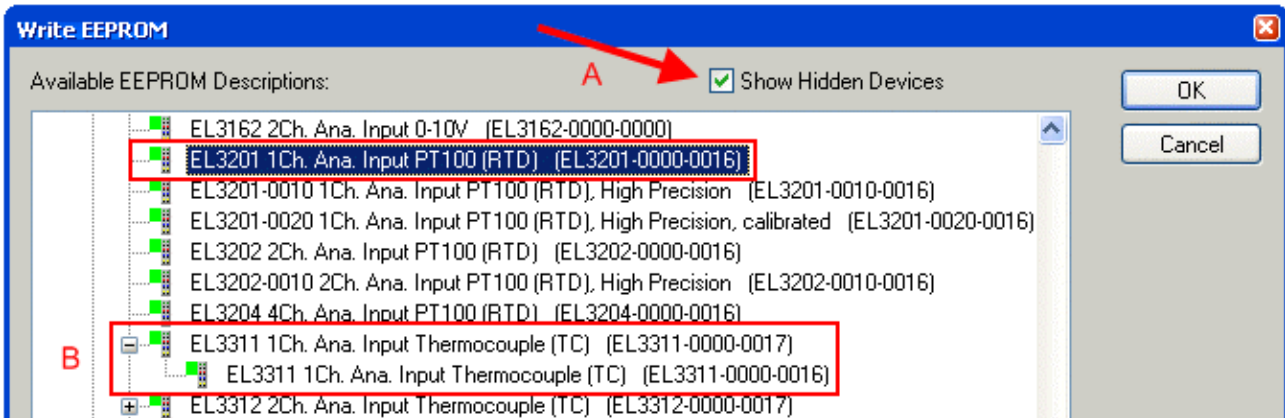



Fig. 179: Selecting the new ESI

A progress bar in the System Manager shows the progress. Data are first written, then verified.

 Note	<p>The change only takes effect after a restart.</p> <p>Most EtherCAT devices read a modified ESI description immediately or after startup from the INIT. Some communication settings such as distributed clocks are only read during power-on. The EtherCAT slave therefore has to be switched off briefly in order for the change to take effect.</p>
--	--

8.2.2 Firmware explanation

Determining the firmware version

Determining the version on laser inscription

Beckhoff EtherCAT slaves feature serial numbers applied by laser. The serial number has the following structure: **KK YY FF HH**

- KK - week of production (CW, calendar week)
- YY - year of production
- FF - firmware version
- HH - hardware version

Example with ser. no.: 12 10 03 02:

- 12 - week of production 12
- 10 - year of production 2010
- 03 - firmware version 03
- 02 - hardware version 02

Determining the version via the System Manager

The TwinCAT System Manager shows the version of the controller firmware if the master can access the slave online. Click on the E-Bus Terminal whose controller firmware you want to check (in the example terminal 2 (EL3204)) and select the tab *CoE Online* (CAN over EtherCAT).

i
Note

CoE Online and Offline CoE

Two CoE directories are available:

- **online**: This is offered in the EtherCAT slave by the controller, if the EtherCAT slave supports this. This CoE directory can only be displayed if a slave is connected and operational.
- **offline**: The EtherCAT Slave Information ESI/XML may contain the default content of the CoE. This CoE directory can only be displayed if it is included in the ESI (e.g. "Beckhoff EL5xxx.xml").

The Advanced button must be used for switching between the two views.

In Fig. *Display of EL3204 firmware version* the firmware version of the selected EL3204 is shown as 03 in CoE entry 0x100A.

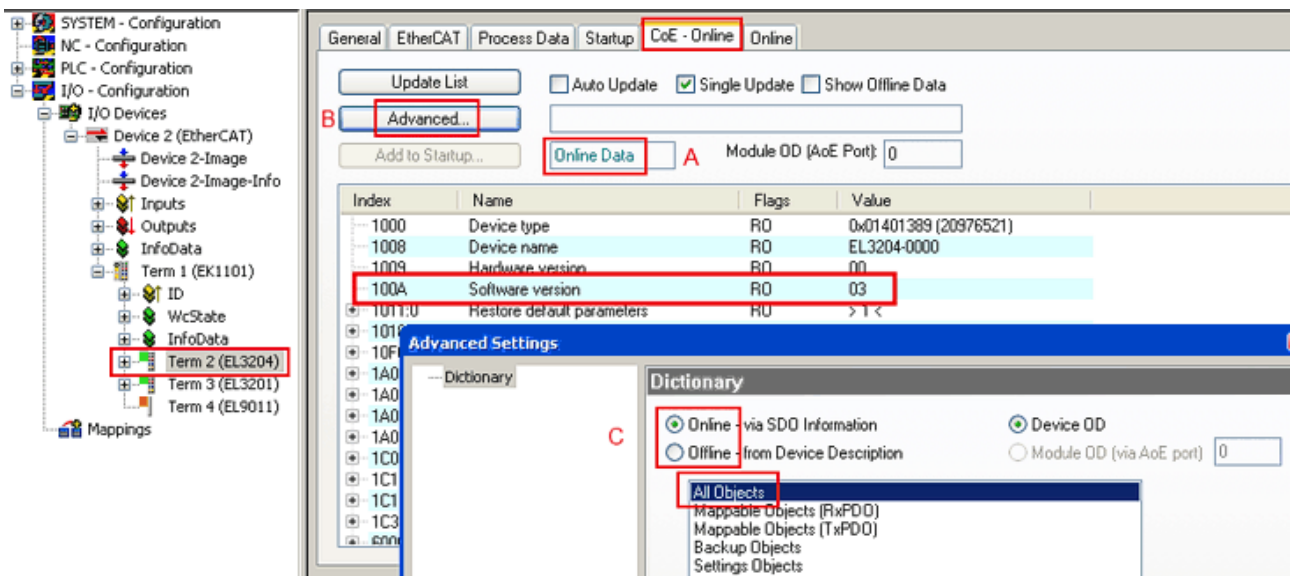



Fig. 180: Display of EL3204 firmware version

In (A) TwinCAT 2.11 shows that the Online CoE directory is currently displayed. If this is not the case, the Online directory can be loaded via the *Online* option in Advanced Settings (B) and double-clicking on *AllObjects*.

8.2.3 Updating controller firmware *.efw

 Note	<p>CoE directory</p> <p>The Online CoE directory is managed by the controller and stored in a dedicated EEPROM, which is generally not changed during a firmware update.</p>
--	---

Switch to the *Online* tab to update the controller firmware of a slave, see Fig. *Firmware Update*.

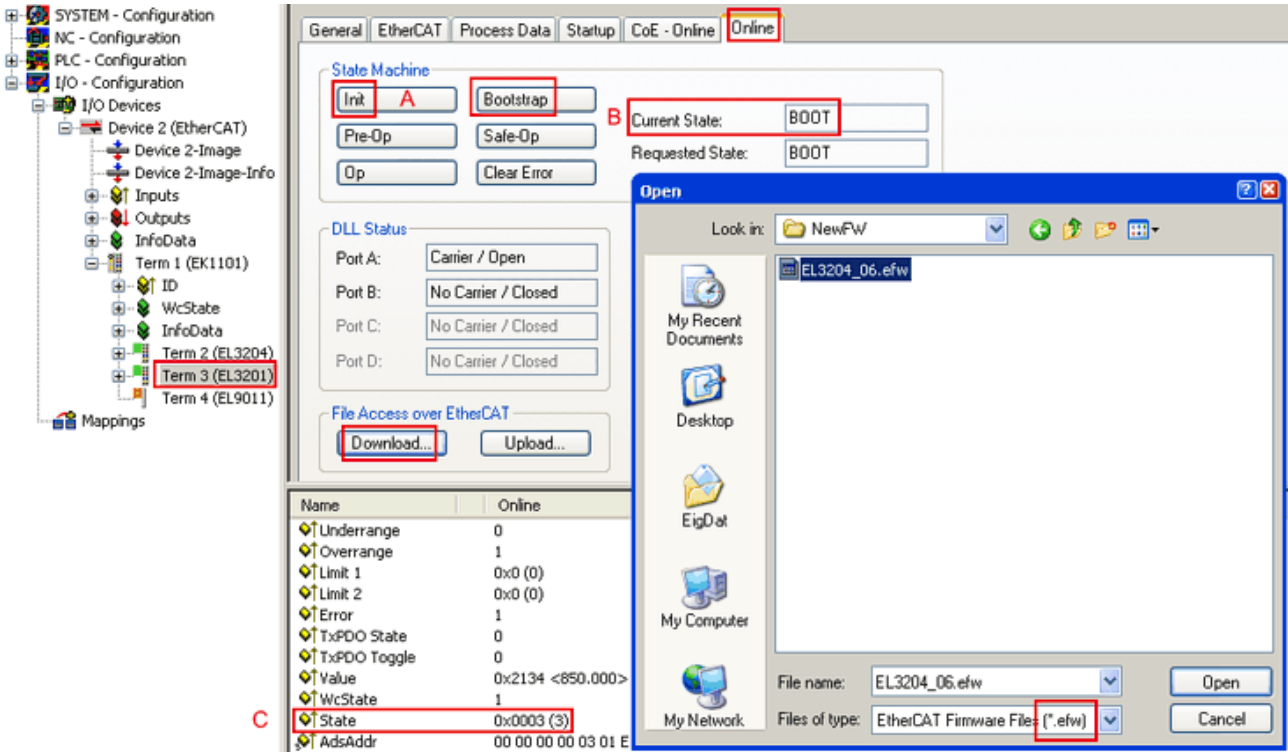
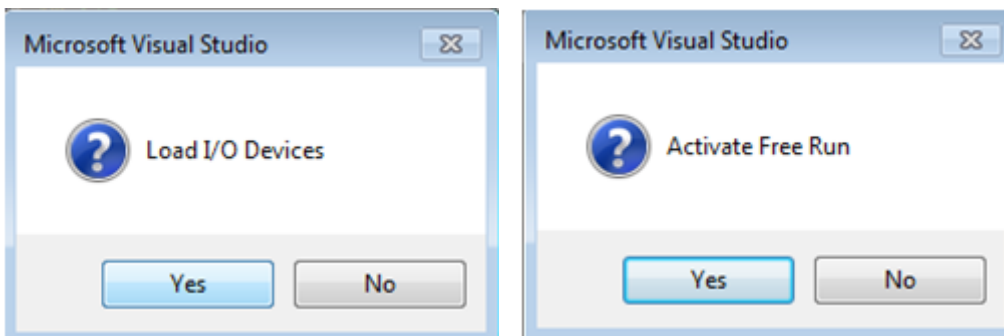

Fig. 181: Firmware Update

Proceed as follows, unless instructed otherwise by Beckhoff support. Valid for TwinCAT 2 and 3 as EtherCAT master.

- Switch TwinCAT system to ConfigMode/FreeRun with cycle time ≥ 1 ms (default in ConfigMode is 4 ms). A FW-Update during real time operation is not recommended.



- Switch EtherCAT Master to PreOP

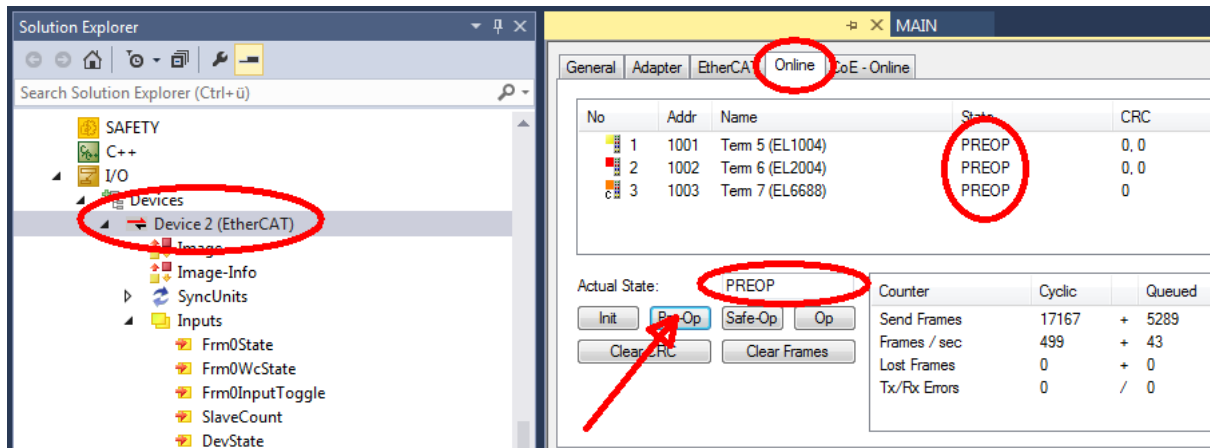

- Switch slave to INIT (A)
- Switch slave to BOOTSTRAP
- Check the current status (B, C)
- Download the new *efw file (wait until it ends). A pass word will not be necessary usually.

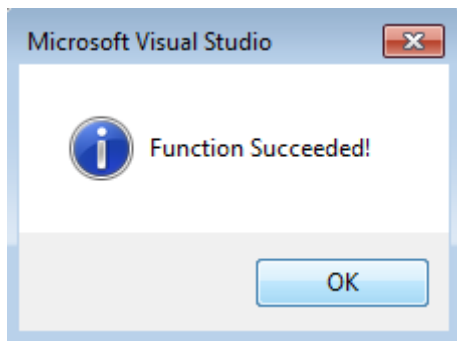

- After the download switch to INIT, then PreOP
- Switch off the slave briefly (don't pull under voltage!)
- Check within CoE 0x100A, if the FW status was correctly overtaken.

8.2.4 FPGA firmware *.rbf

If an FPGA chip deals with the EtherCAT communication an update may be accomplished via an *.rbf file.

- Controller firmware for processing I/O signals
- FPGA firmware for EtherCAT communication (only for terminals with FPGA)

The firmware version number included in the terminal serial number contains both firmware components. If one of these firmware components is modified this version number is updated.

Determining the version via the System Manager

The TwinCAT System Manager indicates the FPGA firmware version. Click on the Ethernet card of your EtherCAT strand (Device 2 in the example) and select the *Online* tab.

The *Reg:0002* column indicates the firmware version of the individual EtherCAT devices in hexadecimal and decimal representation.

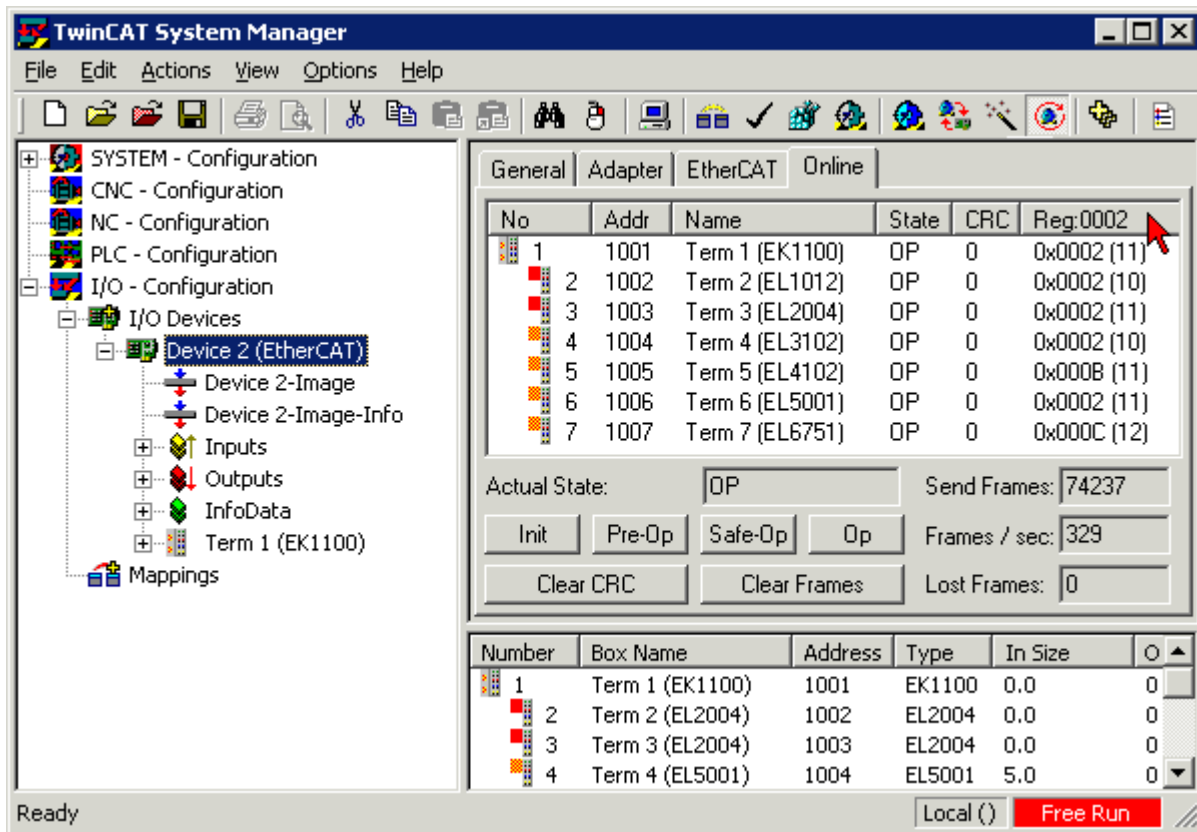

Fig. 182: FPGA firmware version definition

If the column *Reg:0002* is not displayed, right-click the table header and select *Properties* in the context menu.

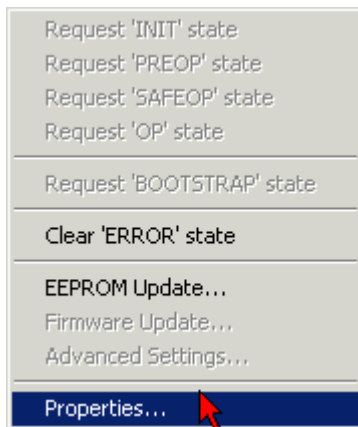

Fig. 183: Context menu *Properties*

The *Advanced Settings* dialog appears where the columns to be displayed can be selected. Under *Diagnosis/Online View* select the *'0002 ETxxxx Build'* check box in order to activate the FPGA firmware version display.

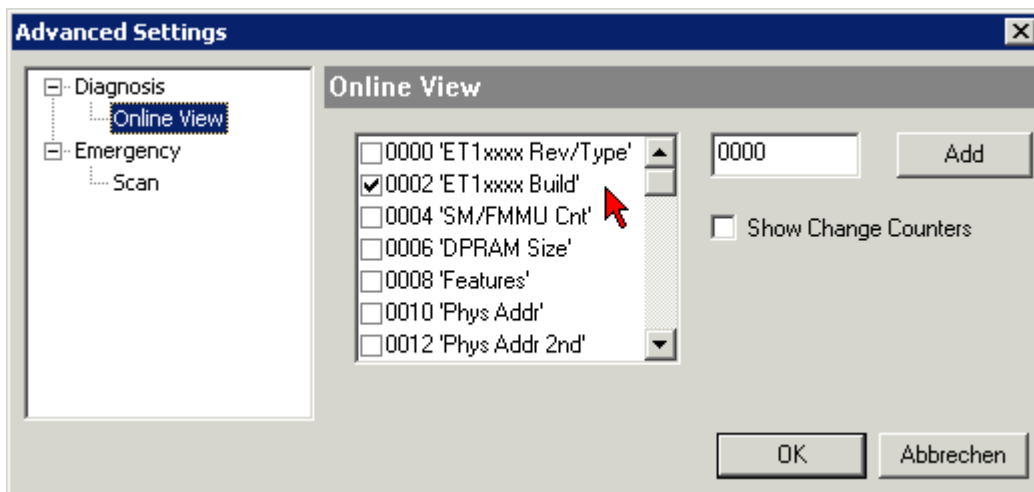

Fig. 184: Dialog *Advanced Settings*

Update

For updating the FPGA firmware

- of an EtherCAT coupler the coupler must have FPGA firmware version 11 or higher;
- of an E-Bus Terminal the terminal must have FPGA firmware version 10 or higher.

Older firmware versions can only be updated by the manufacturer!

Updating an EtherCAT device

The following sequence order have to be met if no other specifications are given (e.g. by the Beckhoff support):

- Switch TwinCAT system to ConfigMode/FreeRun with cycle time ≥ 1 ms (default in ConfigMode is 4 ms). A FW-Update during real time operation is not recommended.

- In the TwinCAT System Manager select the terminal for which the FPGA firmware is to be updated (in the example: Terminal 5: EL5001) and click the *Advanced Settings* button in the *EtherCAT* tab:

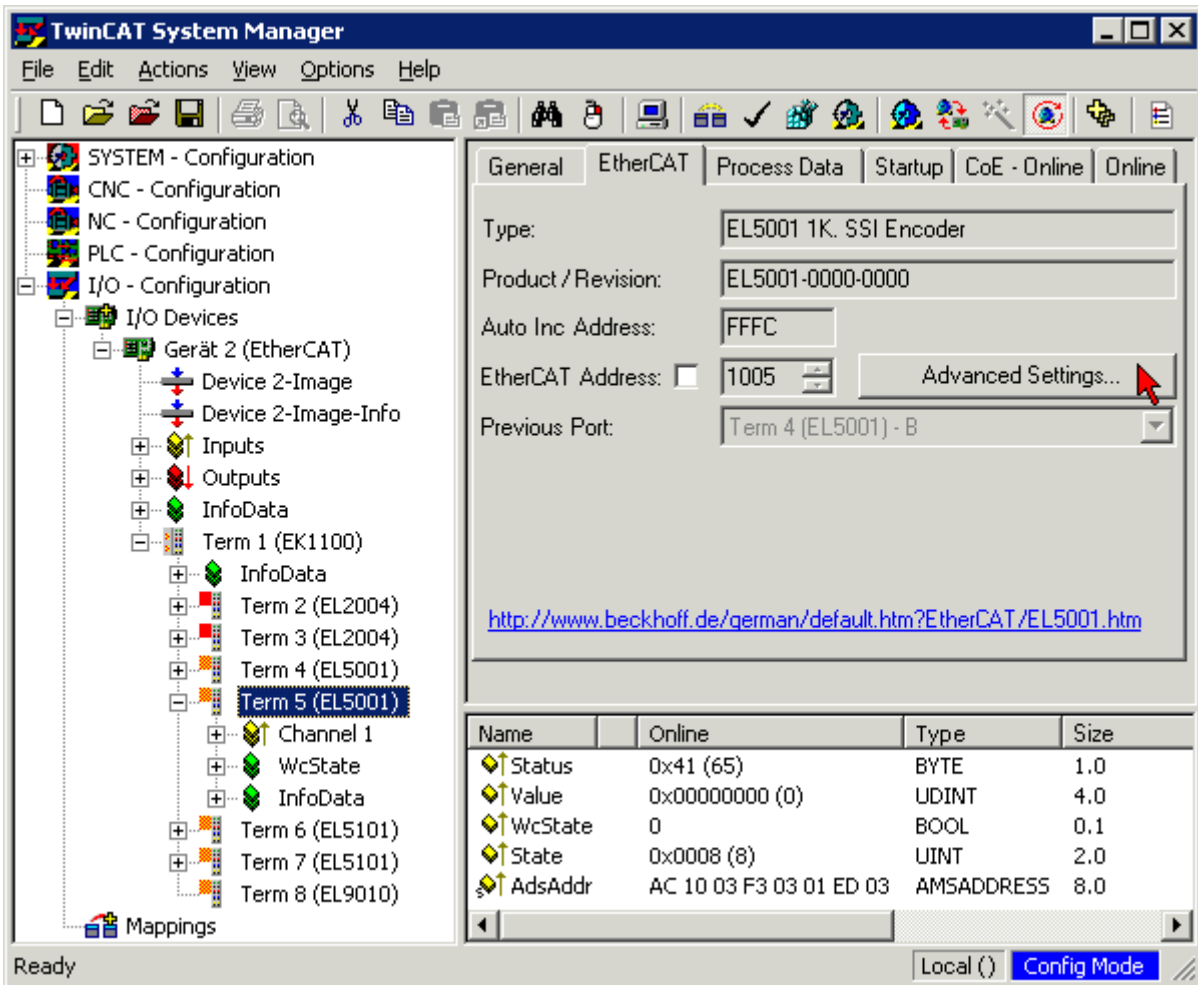

- The *Advanced Settings* dialog appears. Under *ESC Access/E²PROM/FPGA* click on *Write FPGA* button:

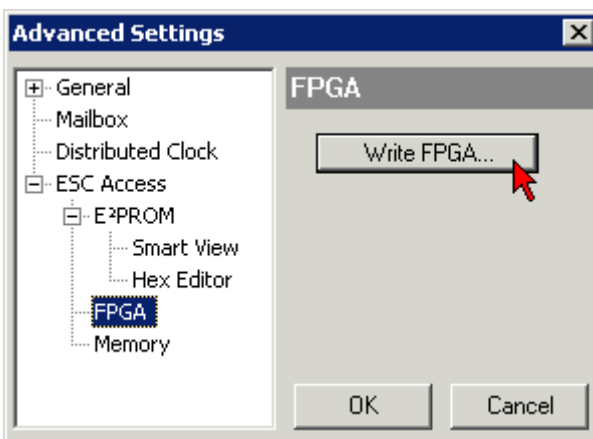

- Select the file (*.rbf) with the new FPGA firmware, and transfer it to the EtherCAT device:

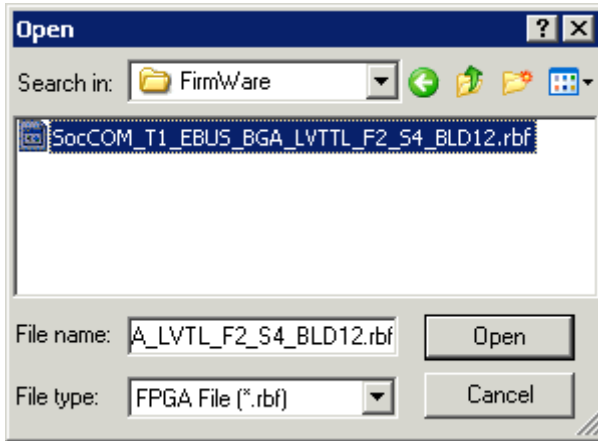

- Wait until download ends
- Switch slave current less for a short time (don't pull under voltage!). In order to activate the new FPGA firmware a restart (switching the power supply off and on again) of the EtherCAT device is required.
- Check the new FPGA status

 Attention	<p>Risk of damage to the device!</p> <p>A download of firmware to an EtherCAT device must not be interrupted in any case! If you interrupt this process by switching off power supply or disconnecting the Ethernet link, the EtherCAT device can only be recommissioned by the manufacturer!</p>
---	--

8.2.5 Simultaneous updating of several EtherCAT devices

The firmware and ESI descriptions of several devices can be updated simultaneously, provided the devices have the same firmware file/ESI.

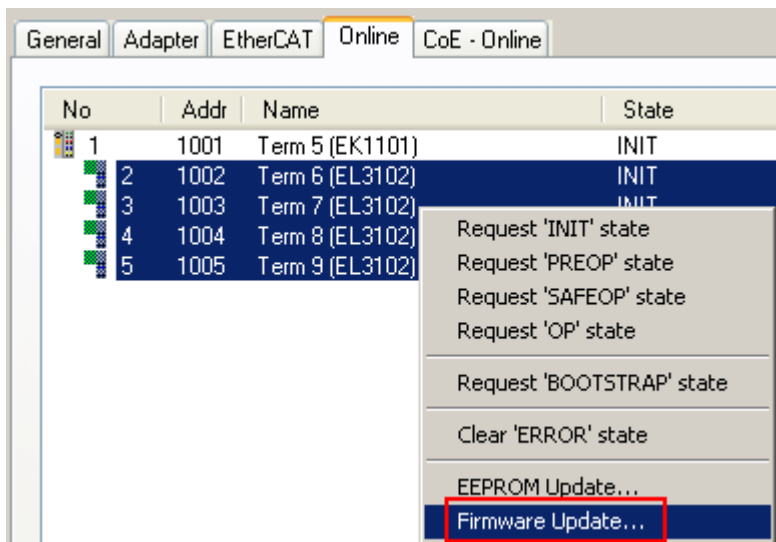

Fig. 185: Multiple selection and firmware update

Select the required slaves and carry out the firmware update in BOOTSTRAP mode as described above.

8.3 Firmware compatibility

Beckhoff EtherCAT devices are delivered with the latest available firmware version. Compatibility of firmware and hardware is mandatory; not every combination ensures compatibility. The overview below shows the hardware versions on which a firmware can be operated.

Note

- It is recommended to use the newest possible firmware for the respective hardware.
- Beckhoff is not under any obligation to provide customers with free firmware updates for delivered products.

 Attention	<p>Risk of damage to the device!</p> <p>Pay attention to the instructions for firmware updates on the separate page ▶ 161. If a device is placed in BOOTSTRAP mode for a firmware update, it does not check when downloading whether the new firmware is suitable. This can result in damage to the device! Therefore, always make sure that the firmware is suitable for the hardware version!</p>
---	--

EL3773			
Hardware (HW)	Firmware (FW)	Revision no.	Release date
00	01	EL3773-0000-0002	2011/08
01 - 05*	02	EL3773-0000-0017	2012/09
	03	EL3773-0000-0018	2012/10
	04		2013/08
	05		2013/08
	06	EL3773-0000-0019	2013/09
	07		2014/12
	08		2015/09
	09	EL3773-0000-0020	2016/05
		EL3773-0000-0021	2016/10
	10*		2017/07

*) This is the current compatible firmware/hardware version at the time of the preparing this documentation. Check on the Beckhoff web page whether more up-to-date [documentation](#) is available.

Note on EL3773 firmware update

 Note	<p>Secondary voltage necessary for firmware updates</p> <p>In order to change the firmware of the EL3773, the permissible operating voltages must be applied both to the fieldbus side (E-Bus) and to the load side (power contacts), otherwise the terminal remains in INIT_ERROR or cannot be switched to BOOTSTRAP mode.</p>
--	--

8.4 Restoring the delivery state

To restore the delivery state for backup objects in ELxxx terminals, the CoE object Restore default parameters, *SubIndex 001* can be selected in the TwinCAT System Manager (Config mode) (see Fig. *Selecting the Restore default parameters PDO*)

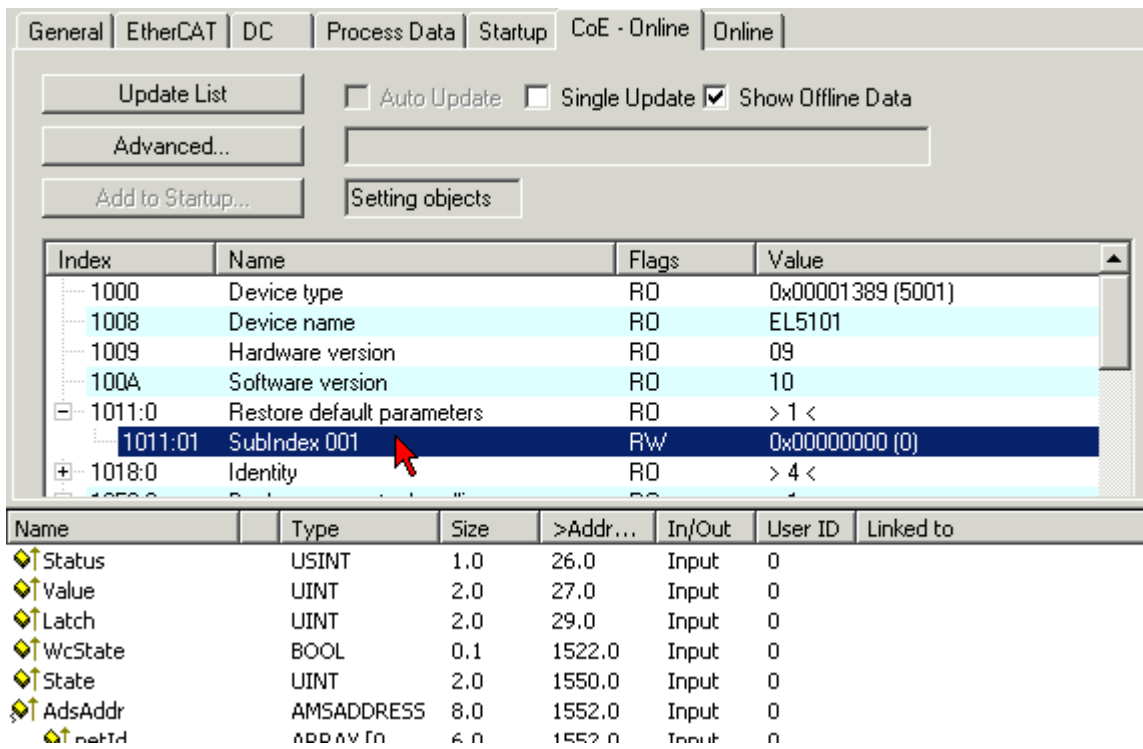

Fig. 186: Selecting the *Restore default parameters* PDO

Double-click on SubIndex 001 to enter the Set Value dialog. Enter the value **1684107116** in field *Dec* or the value **0x64616F6C** in field *Hex* and confirm with *OK* (Fig. *Entering a restore value in the Set Value dialog*). All backup objects are reset to the delivery state.

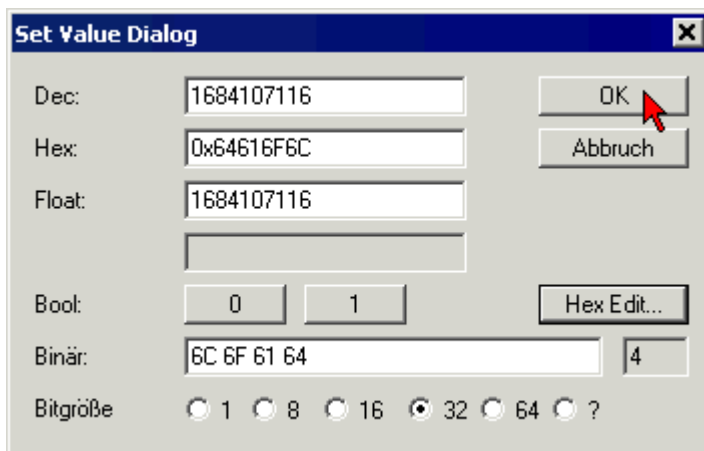

Fig. 187: Entering a restore value in the Set Value dialog



Alternative restore value

In some older terminals the backup objects can be switched with an alternative restore value: Decimal value: 1819238756, Hexadecimal value: 0x6C6F6164An incorrect entry for the restore value has no effect.

Note

8.5 Support and Service

Beckhoff and their partners around the world offer comprehensive support and service, making available fast and competent assistance with all questions related to Beckhoff products and system solutions.

Beckhoff's branch offices and representatives

Please contact your Beckhoff branch office or representative for local support and service on Beckhoff products!

The addresses of Beckhoff's branch offices and representatives round the world can be found on her internet pages:

<http://www.beckhoff.com>

You will also find further documentation for Beckhoff components there.

Beckhoff Headquarters

Beckhoff Automation GmbH & Co. KG

Huelshorstweg 20
33415 Verl
Germany

Phone:	+49(0)5246/963-0
Fax:	+49(0)5246/963-198
e-mail:	info@beckhoff.com

Beckhoff Support

Support offers you comprehensive technical assistance, helping you not only with the application of individual Beckhoff products, but also with other, wide-ranging services:

- support
- design, programming and commissioning of complex automation systems
- and extensive training program for Beckhoff system components

Hotline:	+49(0)5246/963-157
Fax:	+49(0)5246/963-9157
e-mail:	support@beckhoff.com

Beckhoff Service

The Beckhoff Service Center supports you in all matters of after-sales service:

- on-site service
- repair service
- spare parts service
- hotline service

Hotline:	+49(0)5246/963-460
Fax:	+49(0)5246/963-479
e-mail:	service@beckhoff.com

List of illustrations

Fig. 1	EL5021 EL terminal, standard IP20 IO device with serial/ batch number and revision ID (since 2014/01).....	11
Fig. 2	EK1100 EtherCAT coupler, standard IP20 IO device with serial/ batch number.....	11
Fig. 3	CU2016 switch with serial/ batch number.....	12
Fig. 4	EL3202-0020 with serial/ batch number 26131006 and unique ID-number 204418	12
Fig. 5	EP1258-00001 IP67 EtherCAT Box with batch number/ date code 22090101 and unique serial number 158102.....	12
Fig. 6	EP1908-0002 IP67 EtherCAT Safety Box with batch number/ date code 071201FF and unique serial number 00346070	12
Fig. 7	EL2904 IP20 safety terminal with batch number/ date code 50110302 and unique serial number 00331701.....	13
Fig. 8	ELM3604-0002 terminal with unique ID number (QR code) 100001051 and serial/ batch number 44160201.....	13
Fig. 9	EL3773	14
Fig. 10	Voltages in three-phase mains supply of Central Europe.....	16
Fig. 11	System manager current calculation	19
Fig. 12	EtherCAT tab -> Advanced Settings -> Behavior -> Watchdog	20
Fig. 13	States of the EtherCAT State Machine.....	22
Fig. 14	"CoE Online " tab	24
Fig. 15	Startup list in the TwinCAT System Manager	25
Fig. 16	Offline list.....	26
Fig. 17	Online list	27
Fig. 18	Spring contacts of the Beckhoff I/O components.....	29
Fig. 19	Attaching on mounting rail	30
Fig. 20	Disassembling of terminal.....	31
Fig. 21	Power contact on left side.....	32
Fig. 22	Standard wiring.....	33
Fig. 23	Pluggable wiring	34
Fig. 24	High Density Terminals.....	34
Fig. 25	Connecting a cable on a terminal point	35
Fig. 26	Correct positioning	36
Fig. 27	Incorrect positioning.....	37
Fig. 28	Recommended distances for standard installation position	38
Fig. 29	Other installation positions	39
Fig. 30	EL3773	40
Fig. 31	Block diagram	41
Fig. 32	System Manager "Options" (TwinCAT 2).....	44
Fig. 33	Call up under VS Shell (TwinCAT 3)	44
Fig. 34	Overview of network interfaces	44
Fig. 35	EtherCAT device properties(TwinCAT 2): click on „Compatible Devices...“ of tab “Adapter”	45
Fig. 36	Windows properties of the network interface.....	46
Fig. 37	Exemplary correct driver setting for the Ethernet port.....	46
Fig. 38	Incorrect driver settings for the Ethernet port	47
Fig. 39	TCP/IP setting for the Ethernet port	48
Fig. 40	Identifier structure	49
Fig. 41	OnlineDescription information window (TwinCAT 2)	50

Fig. 42	Information window OnlineDescription (TwinCAT 3)	50
Fig. 43	File OnlineDescription.xml created by the System Manager	51
Fig. 44	Indication of an online recorded ESI of EL2521 as an example	51
Fig. 45	Information window for faulty ESI file (left: TwinCAT 2; right: TwinCAT 3).....	51
Fig. 46	Using the ESI Updater (>= TwinCAT 2.11).....	53
Fig. 47	Using the ESI Updater (TwinCAT 3).....	53
Fig. 48	Append EtherCAT device (left: TwinCAT 2; right: TwinCAT 3)	54
Fig. 49	Selecting the EtherCAT connection (TwinCAT 2.11, TwinCAT 3).....	54
Fig. 50	Selecting the Ethernet port	54
Fig. 51	EtherCAT device properties (TwinCAT 2)	55
Fig. 52	Appending EtherCAT devices (left: TwinCAT 2; right: TwinCAT 3).....	55
Fig. 53	Selection dialog for new EtherCAT device	56
Fig. 54	Display of device revision	56
Fig. 55	Display of previous revisions	57
Fig. 56	Name/revision of the terminal	57
Fig. 57	EtherCAT terminal in the TwinCAT tree (left: TwinCAT 2; right: TwinCAT 3).....	58
Fig. 58	Differentiation local/target system (left: TwinCAT 2; right: TwinCAT 3).....	59
Fig. 59	Scan Devices (left: TwinCAT 2; right: TwinCAT 3).....	59
Fig. 60	Note for automatic device scan (left: TwinCAT 2; right: TwinCAT 3).....	60
Fig. 61	Detected Ethernet devices	60
Fig. 62	Example default state	60
Fig. 63	Installing EtherCAT terminal with revision -1018	61
Fig. 64	Detection of EtherCAT terminal with revision -1019	61
Fig. 65	Scan query after automatic creation of an EtherCAT device (left: TwinCAT 2; right: TwinCAT 3)	62
Fig. 66	Manual triggering of a device scan on a specified EtherCAT device (left: TwinCAT 2; right: TwinCAT 3).....	62
Fig. 67	Scan progress exemplary by TwinCAT 2	62
Fig. 68	Config/FreeRun query (left: TwinCAT 2; right: TwinCAT 3).....	62
Fig. 69	Displaying of "Free Run" and "Config Mode" toggling right below in the status bar	62
Fig. 70	TwinCAT can also be switched to this state by using a button (left: TwinCAT 2; right: TwinCAT 3)	62
Fig. 71	Online display example	63
Fig. 72	Faulty identification	63
Fig. 73	Identical configuration (left: TwinCAT 2; right: TwinCAT 3).....	64
Fig. 74	Correction dialog	64
Fig. 75	Name/revision of the terminal	65
Fig. 76	Correction dialog with modifications	66
Fig. 77	Dialog "Change to Compatible Type..." (left: TwinCAT 2; right: TwinCAT 3).....	66
Fig. 78	TwinCAT 2 Dialog Change to Alternative Type	66
Fig. 79	Branch element as terminal EL3751	67
Fig. 80	"General" tab.....	67
Fig. 81	„EtherCAT“ tab.....	68
Fig. 82	"Process Data" tab.....	69
Fig. 83	Configuring the process data.....	70
Fig. 84	„Startup“ tab.....	71
Fig. 85	"CoE – Online" tab	72

Fig. 86	Dialog "Advanced settings"	73
Fig. 87	„Online“ tab	73
Fig. 88	"DC" tab (Distributed Clocks).....	75
Fig. 89	Selection of the diagnostic information of an EtherCAT Slave	77
Fig. 90	Basic EtherCAT Slave Diagnosis in the PLC.....	78
Fig. 91	EL3102, CoE directory	80
Fig. 92	Example of commissioning aid for a EL3204	81
Fig. 93	Default behaviour of the System Manager	82
Fig. 94	Default target state in the Slave	82
Fig. 95	PLC function blocks	83
Fig. 96	Illegally exceeding the E-Bus current	84
Fig. 97	Warning message for exceeding E-Bus current	84
Fig. 98	Data flow diagram input filter	85
Fig. 99	Filter setting via the CoE object "Filter settings" (Index 0x8000:15).....	85
Fig. 100	Amplitude curve	86
Fig. 101	Process data flow EL3773	86
Fig. 102	Linking of 2-bit variable to additional task.....	88
Fig. 103	User settings and vendor calibration in the CoE online directory	88
Fig. 104	EL3773 Selection dialog "Predefined PDO Assignment"	89
Fig. 105	Process image of the EL3773 in the TwinCAT System Manager.....	90
Fig. 106	Samplingtime	92
Fig. 107	EL3773 Selection dialog "Predefined PDO Assignment"	93
Fig. 108	Setting of the oversampling rates via System Manager, "DC" tab.....	93
Fig. 109	Deactivation of the Distributed Clock in the "DC" tab	93
Fig. 110	EL3773 Selection dialog "Predefined PDO Assignment"	94
Fig. 111	Power measurement at a machine	103
Fig. 112	Power measurement with 2 current transformers on a motor.....	104
Fig. 113	Power measurement at ohmic consumers	105
Fig. 114	Oversampling PDO of the EL37xx series and in the comparison with EL31xx	106
Fig. 115	Adding a Scope project into an already existing project.....	107
Fig. 116	Representation of a created PLC array variable („aUI_Samples“) to link with oversampling PDOs of EL3773.....	108
Fig. 117	Insertion of a free task	108
Fig. 118	Task property "Create symbols" must be activated	109
Fig. 119	Insertion of variable "Var 1" fitting to the oversampling (-factor).....	109
Fig. 120	Set up the link of the PLC array variable (left: for the last preceding paragraph Step 2a, right: for the last preceding paragraph Step 2b)	110
Fig. 121	Select the EL3773 PDO "L1 Voltage Samples" to create a link to the PLC array variable „aUI_Samples“	110
Fig. 122	Selection of the oversampling variable with the target browser.....	111
Fig. 123	Appending the variable "aUI_Samples“ below “axis” within the scope project of the solution explorer.....	111
Fig. 124	Example of recording a sine signal with 10 x oversampling at 1 ms measurement cycle time ...	112
Fig. 125	Activation of the ADS server of the EtherCAT device (TwinCAT 3)	113
Fig. 126	Direct access to PDOs of the terminal by ScopeView	113
Fig. 127	PLC declaration	115
Fig. 128	PLC in the System Manager.....	115

Fig. 129 Add Variable Type	115
Fig. 130 Definition of the variable type	116
Fig. 131 Overview of declared types	116
Fig. 132 Linking	117
Fig. 133 Array variables of an oversampling terminal.....	117
Fig. 134 Settings in the additional task.....	117
Fig. 135 Variable browser up to the array VAR152	118
Fig. 136 AddSymbol on the array	118
Fig. 137 Channel settings	118
Fig. 138 Activation of the marks	119
Fig. 139 Illustration of a 10 x oversampling variable of the EL3751 by the Scope2	120
Fig. 140 Activation of the ADS server of the EtherCAT Device (TwinCAT 2).....	121
Fig. 141 Direct access of the Scope2 to the terminal's PDOs	121
Fig. 142 Automatically calculated array variable (red) in the Scope2.....	122
Fig. 143 Full scale value, measuring span	124
Fig. 144 SE and DIFF module as 2-channel version	126
Fig. 145 2-wire connection.....	128
Fig. 146 Connection of externally supplied sensors	129
Fig. 147 2-, 3- and 4-wire connection at single-ended and differential inputs	130
Fig. 148 Common-mode voltage (Vcm).....	131
Fig. 149 recommended operating voltage range	132
Fig. 150 Signal processing analog input.....	132
Fig. 151 Diagram signal delay (step response)	134
Fig. 152 Diagram signal delay (linear)	135
Fig. 153 Visualization of example program for EL3773	137
Fig. 154 Overview of the performance of the calculations.....	138
Fig. 155 Global Variable List.....	140
Fig. 156 First page of the visualization of the example program	141
Fig. 157 Border around the "Go to Errors" button if errors have occurred.....	141
Fig. 158 Second page of the visualization of the EL3773 example program.....	142
Fig. 159 Principle of operation of the data buffer.....	143
Fig. 160 Overview of the performance of the calculations.....	144
Fig. 161 Searching the Ethernet adapter.....	145
Fig. 162 Selection and confirmation of the Ethernet adapter.....	145
Fig. 163 Activation of the configuration.....	145
Fig. 164 Confirming the activation of the configuration.....	146
Fig. 165 Generating variable mapping.....	146
Fig. 166 Restarting TwinCAT in RUN mode	146
Fig. 167 Compile project.....	146
Fig. 168 Confirming program start	147
Fig. 169 EL3773 logger messages	148
Fig. 170 EL3773 Diag Messages.....	148
Fig. 171 EL3773	149
Fig. 172 DiagMessages in the CoE	150
Fig. 173 Implementation of the DiagMessage system in the TwinCAT System Manager	151
Fig. 174 Device identifier consisting of name EL3204-0000 and revision -0016	162

Fig. 175 Scan the subordinate field by right-clicking on the EtherCAT device	163
Fig. 176 Configuration is identical	163
Fig. 177 Change dialog	163
Fig. 178 EEPROM Update	164
Fig. 179 Selecting the new ESI.....	164
Fig. 180 Display of EL3204 firmware version	165
Fig. 181 Firmware Update	166
Fig. 182 FPGA firmware version definition	168
Fig. 183 Context menu Properties	168
Fig. 184 Dialog Advanced Settings	169
Fig. 185 Multiple selection and firmware update	171
Fig. 186 Selecting the Restore default parameters PDO.....	173
Fig. 187 Entering a restore value in the Set Value dialog.....	173