



Operating instructions for

## KL1904

TwinSAFE input terminal with 4 fail-safe inputs

Version: 2.3.1  
Date: 2017-02-08

**BECKHOFF**



# Table of contents

<b>1</b>	<b>Foreword</b>	<b>3</b>
1.1	Notes on the manual	3
1.1.1	Intendent audience	3
1.1.2	Origin of the document	3
1.1.3	Actuality	3
1.1.4	Product properties	3
1.1.5	Disclaimer	3
1.1.6	Trademarks	3
1.1.7	Patent Pending	4
1.1.8	Copyright	4
1.1.9	Delivery conditions	4
1.2	Safety instructions	4
1.2.1	Delivery state	4
1.2.2	Operator's obligation to exercise diligence	4
1.2.3	Description of safety symbols	5
1.2.4	Documentation issue status	6
<b>2</b>	<b>System description</b>	<b>7</b>
2.1	The Beckhoff Bus Terminal system	7
2.1.1	Bus Coupler	8
2.1.2	Bus Terminals	9
2.1.3	K-bus	9
2.1.4	Power contacts	9
2.2	TwinSAFE	10
2.2.1	The I/O construction kit is extended safely	10
2.2.2	Safety concept	10
2.2.3	KL1904, KL2904 – Bus Terminals with 4 fail-safe inputs or outputs	11
2.2.4	KL6904 TwinSAFE logic terminal with 4 fail-safe outputs	11
2.2.5	The fail-safe principle (Fail Stop)	11
<b>3</b>	<b>Product description</b>	<b>12</b>
3.1	General description	12
3.2	Intended use	13
3.3	Technical data	14
3.4	Safety parameters	15
3.5	Dimensions	16

---

<b>4</b>	<b>Operation</b>	<b>17</b>
4.1	Installation	17
4.1.1	Safety instructions	17
4.1.2	Transport / storage	17
4.1.3	Mechanical installation	18
4.1.4	Electrical installation	19
4.1.5	Tested devices	23
4.2	Configuration of the KL1904 in the TwinCAT System Manager	24
4.2.1	Inserting a Beckhoff Bus Coupler	24
4.2.2	Inserting a Beckhoff Bus Terminal	24
4.2.3	Inserting a KL1904	24
4.2.4	Address settings on the TwinSAFE terminals	25
4.2.5	Entering a TwinSAFE address and parameters in the System Manager	26
4.3	Diagnostics	29
4.3.1	Diagnostic LEDs	29
4.4	Maintenance	31
4.4.1	Cleaning	31
4.4.2	Service life	31
4.5	Decommissioning	32
4.5.1	Disposal	32
<b>5</b>	<b>Appendix</b>	<b>33</b>
5.1	Beckhoff Support and Service	33
5.1.1	Beckhoff branches and partner companies Beckhoff Support	33
5.1.2	Beckhoff company headquarters	33
5.2	Certificates	34

# 1 Foreword

## 1.1 Notes on the manual

### 1.1.1 Intendent audience

It is essential that the following notes and explanations are followed when installing and commissioning these components.

This description is only intended for the use of trained specialists in control and automation engineering who are familiar with the applicable national standards. The responsible staff must ensure that the application or use of the products described satisfy all the requirements for safety, including all the relevant laws, regulations, guidelines and standards.

### 1.1.2 Origin of the document

These operating instructions were originally written in German. All other languages are derived from the German original.

### 1.1.3 Actuality

Please check whether you have the latest and valid version of this document. On the Beckhoff homepage under the link <http://www.beckhoff.de/english/download/twinsafe.htm> you may find the latest version for download. If in doubt, please contact the technical support (see chapter 5.1 Beckhoff Support and Service).

### 1.1.4 Product properties

Valid are only the product properties that are specified in the respectively current user documentation. Other information, which is given on the product pages of the Beckhoff homepage, in emails or other publications is not relevant.

### 1.1.5 Disclaimer

The documentation has been prepared with care. The products described are, however, constantly under development. For that reason the documentation is not in every case checked for consistency with performance data, standards or other characteristics.

If it should contain technical or editorial errors, we reserve the right to make changes at any time and without notice.

No claims for the modification of products that have already been supplied may be made on the basis of the data, diagrams and descriptions in this documentation.

### 1.1.6 Trademarks

Beckhoff®, TwinCAT®, EtherCAT®, Safety over EtherCAT®, TwinSAFE® and XFC® are registered trademarks of and licensed by Beckhoff Automation GmbH.

Other designations used in this publication may be trademarks whose use by third parties for their own purposes could violate the rights of the owners.

### 1.1.7 Patent Pending

The EtherCAT technology is patent protected, in particular by the following applications and patents: EP1590927, EP1789857, DE102004044764, DE102007017835 with the corresponding applications and registrations in various other countries.

The TwinCAT technology is patent protected, in particular by the following applications and patents: EP0851348, US6167425 with corresponding applications or registrations in various other countries.

### 1.1.8 Copyright

© Beckhoff Automation GmbH & Co. KG.

The reproduction, distribution and utilization of this document as well as the communication of its contents to others without express authorization are prohibited. Offenders will be held liable for the payment of damages. All rights reserved in the event of the grant of a patent, utility model or design.

### 1.1.9 Delivery conditions

In addition, the general delivery conditions of the company Beckhoff Automation GmbH & Co. KG apply.

## 1.2 Safety instructions

### 1.2.1 Delivery state

All the components are supplied in particular hardware and software configurations appropriate for the application. Modifications to hardware or software configurations other than those described in the documentation are not permitted, and nullify the liability of Beckhoff Automation GmbH & Co. KG.





### 1.2.2 Operator's obligation to exercise diligence

The operator must ensure that

- the TwinSAFE products are only used as intended (see chapter Product description);
- the TwinSAFE products are only operated in sound condition and in working order (see chapter *Cleaning*).
- the TwinSAFE products are operated only by suitably qualified and authorized personnel.
- the personnel is instructed regularly about relevant occupational safety and environmental protection aspects, and is familiar with the operating instructions and in particular the safety instructions contained herein.
- the operating instructions are in good condition and complete, and always available for reference at the location where the TwinSAFE products are used.
- none of the safety and warning notes attached to the TwinSAFE products are removed, and all notes remain legible.

### 1.2.3 Description of safety symbols

The following safety symbols are used in these operating instructions. They are intended to alert the reader to the associated safety instructions.

 <b>DANGER</b>	<b>Serious risk of injury!</b> <b>Failure</b> to follow the safety instructions associated with this symbol directly endangers the life and health of persons.
 <b>WARNING</b>	<b>Caution - Risk of injury!</b> <b>Failure</b> to follow the safety instructions associated with this symbol endangers the life and health of persons.
 <b>CAUTION</b>	<b>Personal injuries!</b> <b>Failure</b> to follow the safety instructions associated with this symbol can lead to injuries to persons.
 <b>Attention</b>	<b>Damage to the environment or devices</b> <b>Failure</b> to follow the instructions associated with this symbol can lead to damage to the environment or equipment.
 <b>Note</b>	<b>Tip or pointer</b> This symbol indicates information that contributes to better understanding.

## 1.2.4 Documentation issue status

Version	Comment
2.3.1	<ul style="list-style-type: none"> <li>• Technical data <i>permissible air pressure</i> expanded</li> </ul>
2.3.0	<ul style="list-style-type: none"> <li>• Reliability document updated</li> <li>• Safety parameters updated</li> <li>• Foreword overworked</li> </ul>
2.2.2	<ul style="list-style-type: none"> <li>• Reliability document updated</li> </ul>
2.2.1	<ul style="list-style-type: none"> <li>• Certificate updated</li> </ul>
2.2.0	<ul style="list-style-type: none"> <li>• Company address amended</li> <li>• Document origin added</li> <li>• Version history added</li> <li>• EN954 example removed</li> <li>• Safety parameters extended</li> </ul>
2.1.1	<ul style="list-style-type: none"> <li>• Reference to EN 60068-2-29 removed</li> </ul>
2.1.0	<ul style="list-style-type: none"> <li>• Version and date updated</li> </ul>
2.0.0	<ul style="list-style-type: none"> <li>• Description of the configuration in the TwinCAT System Manager added</li> <li>• Certificates added</li> </ul>
1.2.3	<ul style="list-style-type: none"> <li>• Diagrams updated</li> </ul>
1.2.2	<ul style="list-style-type: none"> <li>• LED and pin assignment corrected</li> </ul>
1.2.1	<ul style="list-style-type: none"> <li>• LED descriptions added</li> </ul>
1.2.0	<ul style="list-style-type: none"> <li>• Technical data amended</li> <li>• Precise specification of permitted operating environment</li> </ul>
1.1.0	<ul style="list-style-type: none"> <li>• Operation of the KL1904 under TwinCAT added</li> </ul>
1.0.1	<ul style="list-style-type: none"> <li>• Pin assignment added</li> </ul>
1.0.0	<ul style="list-style-type: none"> <li>• First released version</li> </ul>

## 2 System description

### 2.1 The Beckhoff Bus Terminal system

The Beckhoff Bus Terminal system is used for decentralized connection of sensors and actuators to a control system. The Beckhoff Bus Terminal system components are mainly used in industrial automation and building management applications. In its minimum configuration, a bus station consists of a Bus Coupler or a Bus Terminal Controller and Bus Terminals connected to it. The Bus Coupler forms the communication interface to the higher-level controller, and the terminals are the interface to sensors and actuators. The whole bus station is clipped onto a 35 mm DIN mounting rail (EN 60715). The mechanical cross connection of the bus station is established via a slot and key system at the Bus Coupler and the Bus Terminals.

The sensors and actuators are connected with terminals via the screwless Cage Clamp® connection system.

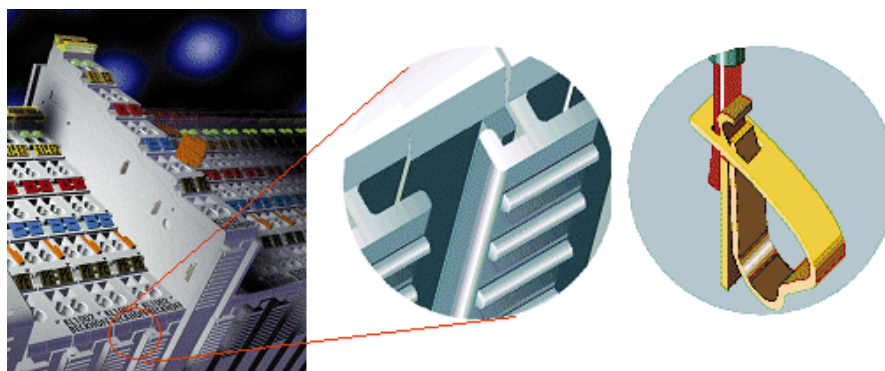

Since a wide range of different communication standards are established in industrial automation, Beckhoff offers Bus Couplers for all common bus systems (e.g. BK3120 for PROFIBUS, BK9000 for Ethernet etc.).

## 2.1.1 Bus Coupler

### Mechanical data

Mechanical data	Bus Coupler
Material	polycarbonate, polyamide (PA6.6).
Dimensions (W x H x D)	47 mm x 100 mm x 68 mm
Mounting	on 35 mm mounting rail (EN 60715) with locking
Attachable by	double slot and key connection

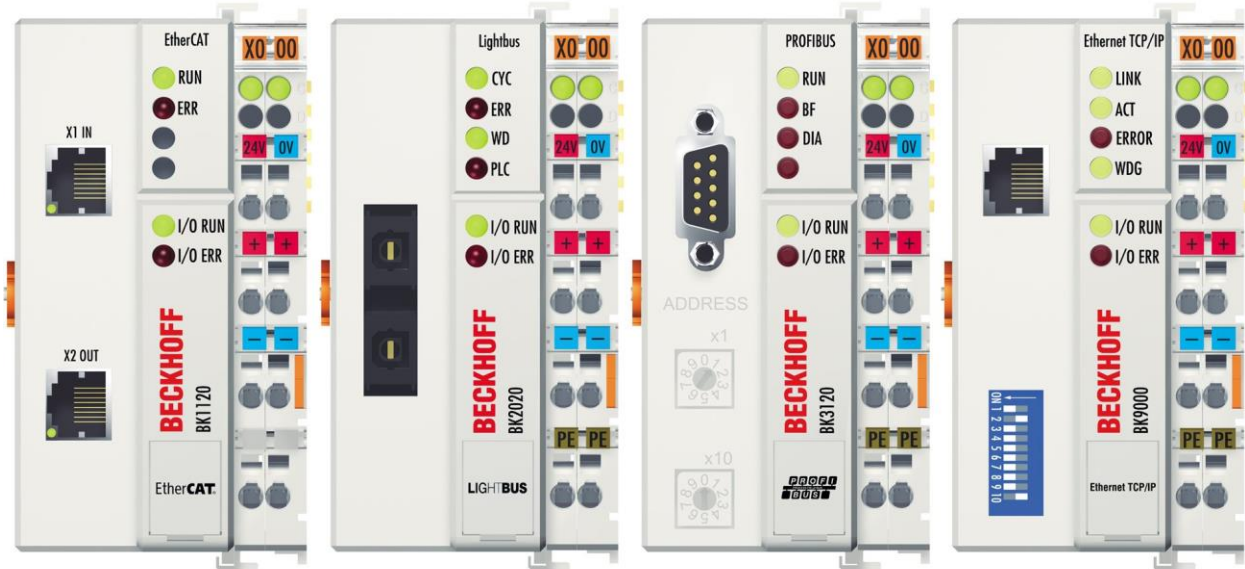

### Connection technology

Connection technology	Bus Coupler
Wiring	cage Clamp® spring-loaded system
Connection cross-section	0.08 mm <sup>2</sup> ... 2.5 mm <sup>2</sup> , stranded wire, solid wire
Fieldbus connection	depending on fieldbus
Power contacts	3 spring contacts
Current load	10 A
Rated voltage	24 V <sub>DC</sub>

### 2.1.2 Bus Terminals

#### Mechanical data

Mechanical data	Bus Terminal
Material	polycarbonate, polyamide (PA6.6).
Dimensions (W x H x D)	(12 mm x 100 mm x 68 mm)
Mounting	on 35 mm mounting rail (EN 60715) with locking
Attachable by	double slot and key connection

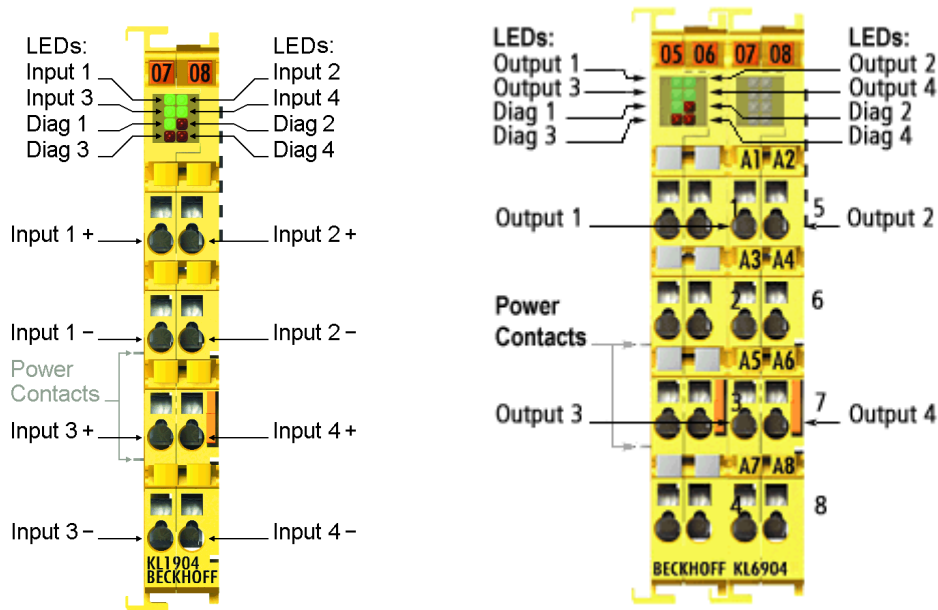

#### Connection technology

Connection technology	Bus Terminal
Wiring	cage Clamp® spring-loaded system
Connection cross-section	0.08 mm² ... 2.5 mm², stranded wire, solid wire
Fieldbus connection	depending on fieldbus
Power contacts	up to 3 blade/spring contacts
Current load	10 A
Rated voltage	depends on Bus Terminal type

### 2.1.3 K-bus

The K-Bus is the data path within a terminal strip. The K-Bus is led through from the Bus Coupler through all the terminals via six contacts on the terminals' side walls. The end terminal terminates the K-Bus.

### 2.1.4 Power contacts

The operating voltage is passed on to following terminals via two power contacts. Terminal strip can be split into galvanically isolated groups by means of potential feed terminals as required. The power feed terminals play no part in the control of the terminals, and can be inserted at any locations within the terminal strip.

## 2.2 TwinSAFE

### 2.2.1 The I/O construction kit is extended safely

With the TwinSAFE Terminals, Beckhoff offers the option of simply expanding the proven Bus Terminal system, and to transfer the complete cabling for safety circuits into the already existing fieldbus cable. Safe signals can be mixed with standard signals without restriction. This saves design effort, installation and material. Maintenance is simplified significantly through faster diagnosis and simple replacement of only a few components.

The new KLx9xx series Bus Terminals only include three basic functionalities: digital KL19xx inputs, digital KL29xx outputs and a KL6904 link unit. For a large number of applications, all sensors and actuators can be wired on these Bus Terminals. The required logical link of the inputs and the outputs is handled by the KL6904. For small to medium-sized configurations, the tasks of a fail-safe PLC can thus be handled within the Bus Terminal system.

### 2.2.2 Safety concept

#### **TwinSAFE: Safety and I/O technology in one system**

- Extension of the familiar Beckhoff I/O system with TwinSAFE terminals
- Freely selectable mix of safe and standard signals
- Logic link of the I/Os in the KL6904 TwinSAFE logic terminal
- Safety-relevant networking of machines via bus systems

#### **TwinSAFE protocol (FSoE)**

- Transfer of safety-relevant data via any media ("genuine black channel")
- TwinSAFE communication via fieldbus systems such as EtherCAT, Lightbus, PROFIBUS or Ethernet
- IEC 61508:2010 SIL 3 compliant

#### **Configuring instead of wiring: the TwinSAFE configurator**

- Configuration of the TwinSAFE system via the TwinCAT System Manager
- System Manager for editing and displaying all bus parameters
- Certified function blocks such as emergency stop, operation mode, etc.
- Simple handling
- Typical function blocks for machine safety
- Freely selectable fieldbus connection with the KL6904 TwinSAFE logic terminal

#### **KL6904 TwinSAFE logic terminal**

- Link unit between TwinSAFE input and output terminals
- Configuration of a simple, flexible, cost-effective, decentralized safety controller
- No safety requirements for higher-level control system
- TwinSAFE enables networks with up to 1023 TwinSAFE devices
- TwinSAFE logic terminal can establish up to 15 connections (TwinSAFE connections).
- Several TwinSAFE logic terminals are cascadable in a network
- Safety functions such as emergency stop, protective door, etc. are already included
- Safe outputs integrated
- Suitable for applications up to SIL 3 according to IEC 61508:2010

**TwinSAFE digital input (KL1904) and output terminal (KL2904)**

- All current safety sensors can be connected
- Operation with a TwinSAFE logic terminal
- KL1904 with 4 fail-safe inputs for sensors (24 V<sub>DC</sub>) with floating contacts
- KL2904 with four safe channels for actuators (24 V<sub>DC</sub>, 0.5 A per channel)
- conforming to IEC 61508:2010 SIL 3

**2.2.3 KL1904, KL2904 – Bus Terminals with 4 fail-safe inputs or outputs**

The KL1904 and KL2904 Bus Terminals enable connection of common safety sensors and actuators. They are operated with the KL6904 TwinSAFE logic terminal. The TwinSAFE logic terminal is the link unit between the TwinSAFE input and output terminals. It enables the configuration of a simple, flexible and cost-effective decentralized safety control system.

Therefore, there are no safety requirements for the higher-level controller! The typical safety functions required for the automation of machines, such as emergency stop, protective door, two-hand etc., are already permanently programmed in the KL6904. The user configures the KL6904 terminal according to the safety requirements of his application.

**2.2.4 KL6904 TwinSAFE logic terminal with 4 fail-safe outputs**

The KL6904 TwinSAFE logic terminal is a digital output terminal with four fail-safe outputs with 0.5 A, 24 V<sub>DC</sub>. The KL6904 meets the requirements of IEC 61508:2010 SIL 3 and DIN EN ISO 13849-1:2006 (Cat 4, PL e).

**2.2.5 The fail-safe principle (Fail Stop)**

The basic rule for a safety system such as TwinSAFE is that failure of a part, a system component or the overall system must never lead to a dangerous condition. The safe state is always the switched off and wattless state.

## 3 Product description

### 3.1 General description

#### KL1904 - TwinSAFE digital four channel input terminal

The KL1904 is a digital input terminal for transducers with floating contacts for 24 V<sub>DC</sub>. The Bus Terminal has 4 fail-safe inputs.

With two-channel connection, the KL1904 meets the requirements of IEC 61508:2010 SIL 3, DIN EN ISO 13849-1:2006 (Cat 4, PL e), NRTL, UL508, UL1998 and UL991.

The Bus Terminal has the standard design of a Beckhoff Bus Terminal.

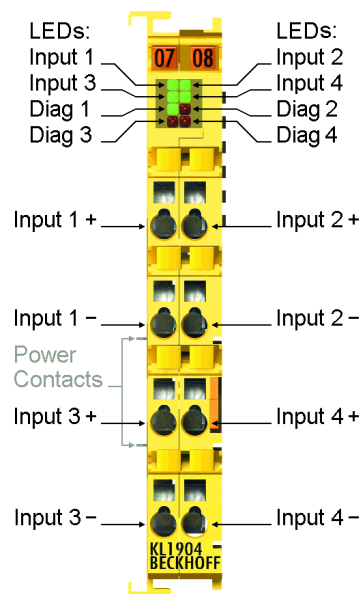

## 3.2 Intended use

 <b>WARNING</b>	<p><b>Caution - Risk of injury!</b></p> <p>TwinSAFE terminals may only be used for the purposes described below!</p>
---	--

The TwinSAFE terminals expand the application range of Beckhoff Bus Terminal system with functions that enable them to be used for machine safety applications. The TwinSAFE terminals are designed for machine safety functions and directly associated industrial automation tasks. They are therefore only approved for applications with a defined fail-safe state. This safe state is the wattless state. Fail-safety according to the relevant standards is required.

The TwinSAFE terminals enable connection of:

- 24 V<sub>DC</sub> sensors (KL1904) such as emergency off pushbutton switches, pull cord switches, position switches, two-hand switches, safety mats, light curtains, light barriers, laser scanner, etc.
- 24 V<sub>DC</sub> actuators (KL2904, KL6904) such as contactors, protection door switches with tumbler, signal lamps, servo drives, etc.

The following modules were developed for these tasks:

- The KL1904 terminal is an input module with digital inputs.
- The KL2904 terminal is an output module with digital outputs.
- The KL6904 terminal is a logic module with digital outputs.

These modules are suitable for operation with

- Beckhoff BKxxxx series Bus Couplers
- Beckhoff BXxxxx series Bus Terminal Controllers (with firmware version  $\geq 1.20$ ) (Beckhoff BCxxxx series Bus Terminal Controllers are not supported!)
- Beckhoff CXxxxx series Embedded PCs with K-Bus connection

 <b>CAUTION</b>	<p><b>Follow the machinery directive</b></p> <p>The TwinSAFE terminals may only be used in machines according to the machinery directive.</p>
---	---

 <b>CAUTION</b>	<p><b>Ensure traceability</b></p> <p>The buyer has to ensure the traceability of the device via the serial number.</p>
---	--

### 3.3 Technical data

Product designation		KL1904
Number of inputs		4
Number of outputs		0
Status display		4 (one green LED per input)
Reaction time (read input/write to K-Bus)		typically: 4 ms, maximally: see error reaction time
Error reaction time		≤ watchdog time
Cable length between sensor and terminal	(unshielded)	100 m max.(at 0.75 or 1 mm <sup>2</sup> )
	(shielded)	100 m max.(at 0.75 or 1 mm <sup>2</sup> )
Input process image		6 bytes
Output process image		6 bytes
KL1904 supply voltage		24 V <sub>DC</sub> (-15% / +20%)
Current consumption of the modular electronics at 24 V (without current consumption of sensors)		4 channels occupied: typically 12 mA 0 channels occupied: typically 1 mA
Current consumption from K-bus		4 channels occupied: typically 47 mA 0 channels occupied: typically 33 mA
Power dissipation of the terminal		typically 540 mW
Electrical isolation (between the channels)		no
Electrical isolation (between the channels and the K-Bus)		yes
Insulation voltage (between the channels and the K-Bus, under common operating conditions)		insulation tested with 500 V <sub>DC</sub>
Dimensions (W x H x D)		12mm x 100mm x 68mm
Weight		approx. 50 g
Permissible ambient temperature (operation)		-0°C to +55°C
Permissible ambient temperature (transport/storage)		-25°C to +70°C
Permissible air humidity		5% to 95%, non-condensing
Permissible air pressure (operation/storage/transport)		750 hPa to 1100 hPa (this corresponds to a height of approx. -690 m to 2450 m over sea level assuming an international standard atmosphere)
Climate category according to EN 60721-3-3		3K3
Permissible level of contamination		level of contamination 2 (comply with the chapter Cleaning)
Impermissible operating conditions		TwinSAFE terminals must not be used under the following operating conditions: <ul style="list-style-type: none"> <li>• under the influence of ionizing radiation</li> <li>• in corrosive environments</li> <li>• in an environment that leads to unacceptable soiling of the Bus Terminal</li> </ul>
EMC immunity/emission		conforms to EN 61000-6-2 / EN 61000-6-4
Vibration/shock resistance		conforms to EN 60068-2-6 / EN 60068-2-27
Shocks		15 g with pulse duration 11 ms in all three axes
Protection class		IP20
Permitted operating environment		control cabinet or terminal box with minimum protection class IP54 according to IEC 60529
Permissible installation position		variable
Approvals		CE

### 3.4 Safety parameters

Key figures	KL1904
Lifetime [a]	20
Proof test Interval [a]	not required <sup>1)</sup>
PFH <sub>D</sub>	2.30E-09
%SIL3	2,3%
PFD	1.81E-04
%SIL3	18,1%
MTTF <sub>d</sub>	High
DC	High
Performance level	PL e
Category	4
HFT	1
Element classification <sup>2)</sup>	Type B

<sup>1)</sup> Special proof tests are not required during the entire service life of the KL1904 Bus Terminal.

<sup>2)</sup> Classification according to IEC 61508-2:2010 (see chapters 7.4.4.1.2 and 7.4.4.1.3)

The KL1904 Bus Terminal can be used for safety-related applications within the meaning of IEC 61508:2010 up to SIL3 and EN ISO 13849-1 up to PL e (Cat4).

To calculate or estimate the MTTF<sub>d</sub> value out of the PFH<sub>D</sub> value please refer to the Application Guide TwinSAFE or to the ISO 13849-1:2015 table K.1.

### 3.5 Dimensions

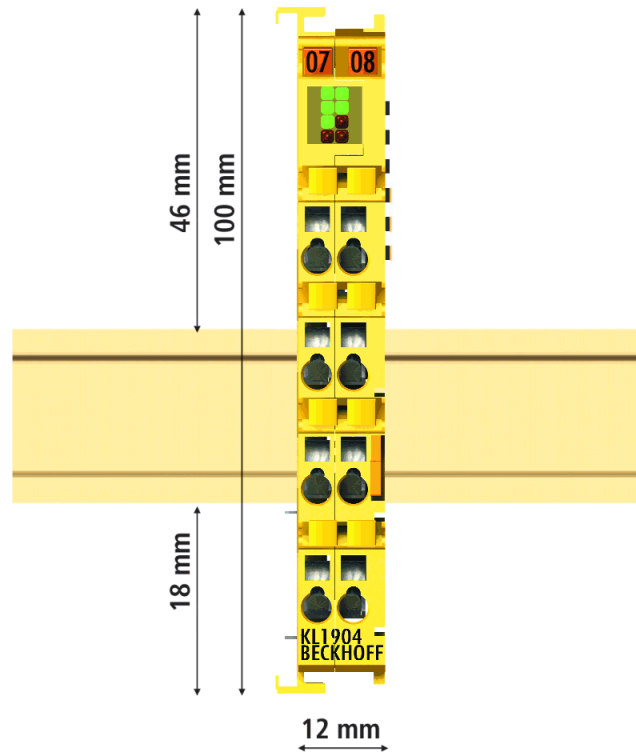

Width: 12 mm (side-by-side installation)

Height: 100 mm

Depth: 68 mm

## 4 Operation

Please ensure that the TwinSAFE terminals are only transported, stored and operated under the specified conditions (see technical data)!

 <b>WARNING</b>	<b>Caution - Risk of injury!</b> The TwinSAFE terminals must not be used under the following operating conditions: <ul style="list-style-type: none"><li>• under the influence of ionizing radiation</li><li>• in corrosive environments</li><li>• in an environment that leads to unacceptable soiling of the Bus Terminal</li></ul>
---	--

### 4.1 Installation

#### 4.1.1 Safety instructions

Before installing and commissioning the TwinSAFE terminals please read the safety notes in the foreword of this documentation.

#### 4.1.2 Transport / storage

Use the original packaging for transporting or storing the digital TwinSAFE terminals.

 <b>CAUTION</b>	<b>Note the specified environmental conditions</b> Please ensure that the digital TwinSAFE terminals are only transported and stored under the specified environmental conditions (see technical data).
---	--

### 4.1.3 Mechanical installation

 <b>DANGER</b>	<p><b>Serious risk of injury!</b></p> <p>Bring the bus system into a safe, de-energized state before starting installation, disassembly or wiring of the Bus Terminals!</p>
--	---

#### 4.1.3.1 Control cabinet

The TwinSAFE terminals must be installed in a control cabinet or terminal box with IP54 protection class according to IEC 60529 as a minimum.

#### 4.1.3.2 Mounting rail installation

##### Mounting

The Bus Couplers and Bus Terminals are attached to commercially available 35 mm mounting rails (according to EN 60715) by applying slight pressure:

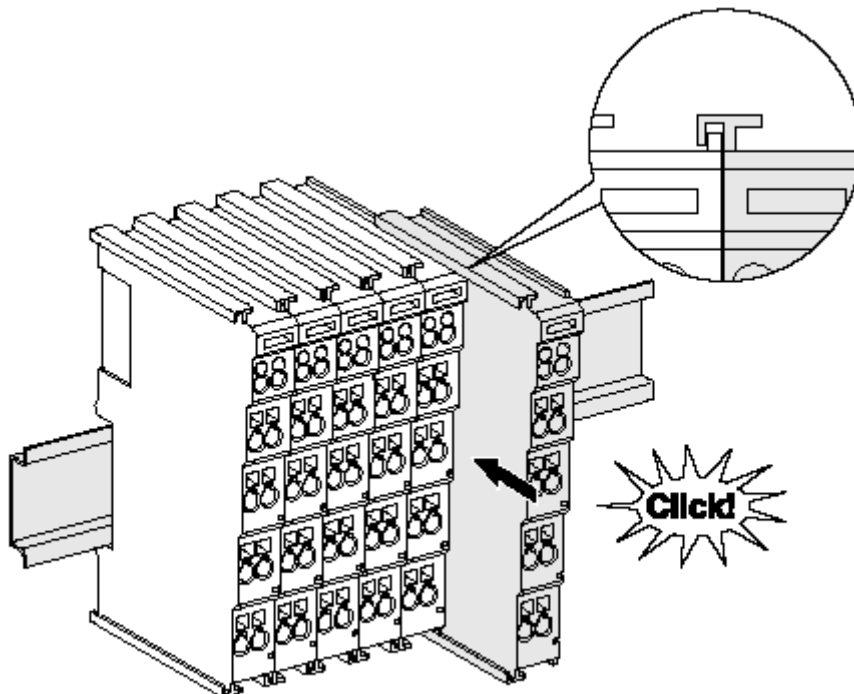

1. First attach the Fieldbus Coupler to the mounting rail.
2. The Bus Terminals are now attached on the right-hand side of the fieldbus Coupler. Join the components with slot and key and push the terminals against the mounting rail, until the lock clicks onto the mounting rail.

If the terminals are clipped onto the mounting rail first and then pushed together without slot and key, the connection will not be operational! When correctly assembled, no significant gap should be visible between the housings.

During the installation of the Bus Terminals, the locking mechanism of the terminals must not come into conflict with the fixing bolts of the mounting rail.

## Removal

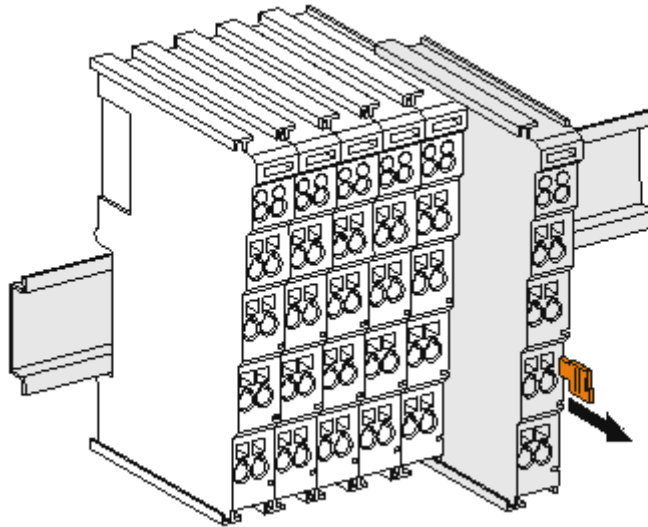

1. Carefully pull the orange-colored lug approximately 1 cm out of the terminal to be disassembled, until it protrudes loosely. The lock with the mounting rail is now released for this terminal, and the terminal can be pulled from the mounting rail without excessive force.
2. Grasp the released terminal with thumb and index finger simultaneous at the upper and lower grooved housing surfaces and pull the terminal away from the mounting rail.

## 4.1.4 Electrical installation

### 4.1.4.1 Connections within a Bus Terminal block

The electric connections between the Bus Coupler and the Bus Terminals are automatically realized by joining the components:

- The six spring contacts of the K-Bus deal with the transfer of the data and the supply of the Bus Terminal electronics.



**Note**

#### **Note the maximum K-Bus current!**

Observe the maximum current that your Bus Coupler can supply to the K-Bus! Use the KL9400 Power Supply Terminal if the current consumption of your terminals exceeds the maximum current that your Bus Coupler can feed to the K-Bus supply.

- The power contacts deal with the supply for the field electronics and thus represent a supply rail within the Bus Terminal block. The power contacts are supplied via terminals on the Bus Coupler.



**Note**

#### **Note the pin assignment of the power contacts!**

During the design of a Bus Terminal block, the pin assignment of the individual Bus Terminals must be taken account of, since some types (e.g. analog Bus Terminals or digital 4-channel Bus Terminals) do not or not fully loop through the power contacts. Power Feed Terminals (KL91xx, KL92xx) interrupt the power contacts and thus represent the start of a new supply rail.

**PE power contact**

The power contact labelled PE can be used as a protective earth. For safety reasons this contact mates first when plugging together, and can ground short-circuit currents of up to 125 A.

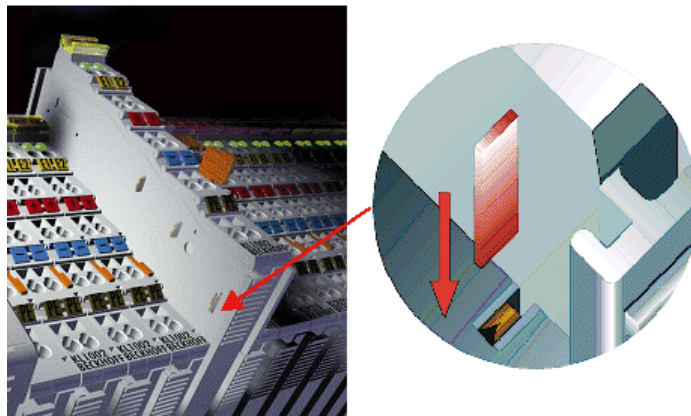

 <b>CAUTION</b>	<p><b>Insulation tests</b></p> <p>Note that, for reasons of electromagnetic compatibility, the PE contacts are capacitatively coupled to the mounting rail. This may lead to incorrect results during insulation testing or to damage on the terminal (e.g. disruptive discharge to the PE line during insulation testing of a consumer with a rated voltage of 230 V). For insulation testing, disconnect the PE supply line at the Bus Coupler or the Power Feed Terminal! In order to decouple further feed points for testing, these Power Feed Terminals can be released and pulled at least 10 mm from the group of terminals.</p>
---	--

 <b>DANGER</b>	<p><b>Serious risk of injury!</b></p> <p>The PE power contact must not be used for other potentials!</p>
--	--

## 4.1.4.2 Wiring

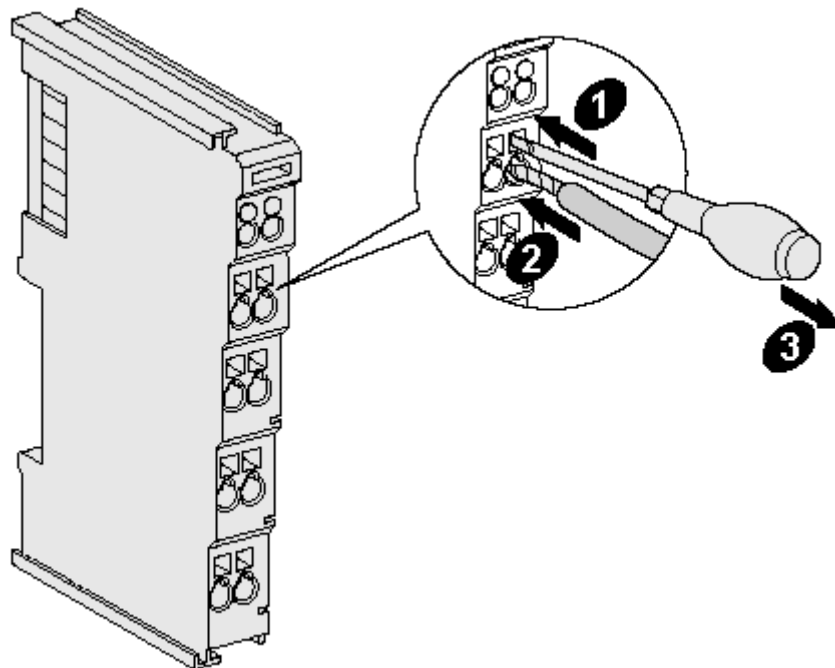

Up to eight connections enable the connection of solid or finely stranded cables to the Bus Terminals. The terminals are implemented in spring force technology. Connect the cables as follows:

1. Open a spring-loaded terminal by slightly pushing with a screwdriver or a rod into the square opening above the terminal.
2. The wire can now be inserted into the round terminal opening without any force.
3. The terminal closes automatically when the pressure is released, holding the wire safely and permanently.

<b>Wire cross section</b>	0.08 ... 2.5 mm <sup>2</sup>
<b>Strip length</b>	8 mm

**KL1904 pin assignment**

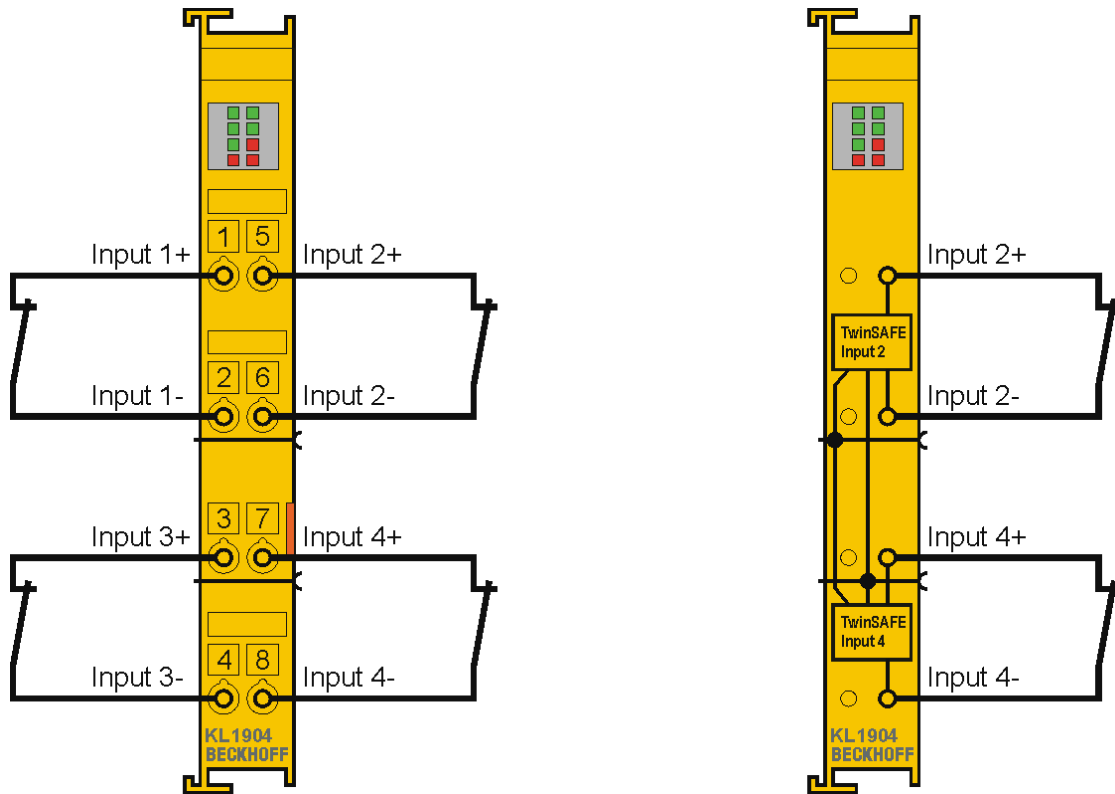

Terminal point	Input	Signal
1	1	Input 1+
2		Input 1-
3	3	Input 3+
4		Input 3-
5	2	Input 2+
6		Input 2-
7	4	Input 4+
8		Input 4-



**Note**

**Configurable inputs**

The inputs 1 to 4 can be occupied as you want with normally closed contacts or normally open contacts. The corresponding analysis is carried out in the safety PLC.

### 4.1.5 Tested devices

The following list contains devices that were tested together with the KL1904 TwinSAFE terminal. The results only apply for the current device hardware version at the time of testing. The tests were carried out in a laboratory environment. Modifications of these products cannot be considered here. If you are unsure please test the hardware together with the TwinSAFE terminal.

Manufacturer	Type	Comment
SICK	C4000	Safety light curtain
Wenglor	SG2-14ISO45C1	Safety light grids
Leuze	lumiflex ROBUST 42/43/44	Safety light barriers
Schmersal	BNS250-11ZG	Safety switch
ifm	GM701S	Inductive safety sensor

The tests were carried out as function tests only. The information provided in the respective manufacturer documentation remains valid.

## 4.2 Configuration of the KL1904 in the TwinCAT System Manager



### Do not change the register values!

Do not change the register values for the TwinSAFE terminals. Changes to the register values (e.g. with the KS2000 configuration software or via register communication) sets the terminal permanently in the Fail-Stop state!

### 4.2.1 Inserting a Beckhoff Bus Coupler

See TwinCAT automation software documentation.

### 4.2.2 Inserting a Beckhoff Bus Terminal

See TwinCAT automation software documentation.

### 4.2.3 Inserting a KL1904

A KL1904 is inserted in the same way as any other Beckhoff Bus Terminal. In the list open *Safety Terminals (KLx9xx)* and select the KL1904.

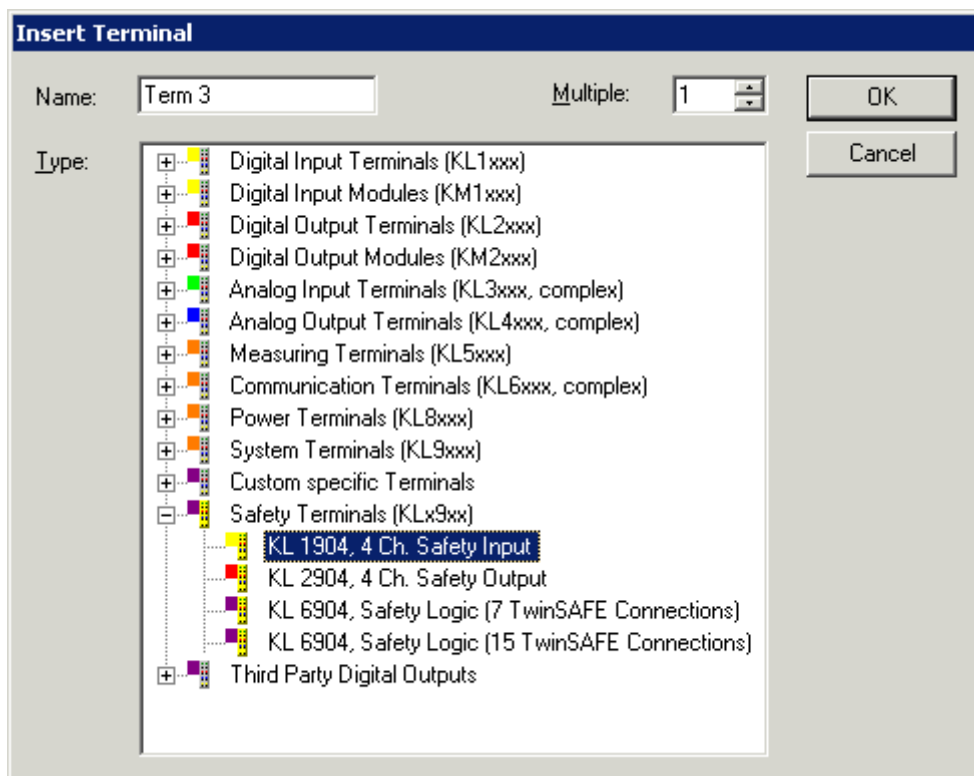

### 4.2.4 Address settings on the TwinSAFE terminals

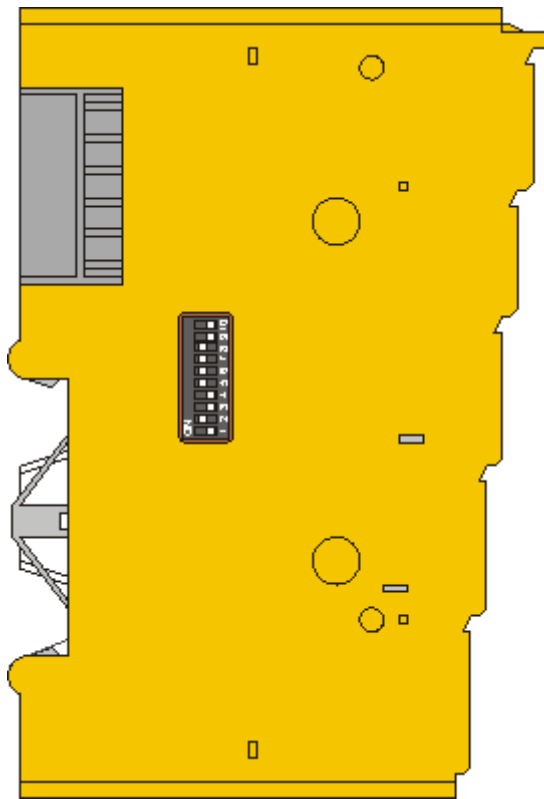

The TwinSAFE address of the terminal is set via the 10-way DIP switch on the left-hand side of the TwinSAFE terminal. TwinSAFE addresses between 1 and 1023 are available.

DIP switch										Address
1	2	3	4	5	6	7	8	9	10	
OFF	OFF	OFF	OFF	OFF	OFF	OFF	OFF	OFF	OFF	0
ON	OFF	OFF	OFF	OFF	OFF	OFF	OFF	OFF	OFF	1
OFF	ON	OFF	OFF	OFF	OFF	OFF	OFF	OFF	OFF	2
ON	ON	OFF	OFF	OFF	OFF	OFF	OFF	OFF	OFF	3
OFF	OFF	ON	OFF	OFF	OFF	OFF	OFF	OFF	OFF	4
ON	OFF	ON	OFF	OFF	OFF	OFF	OFF	OFF	OFF	5
OFF	ON	ON	OFF	OFF	OFF	OFF	OFF	OFF	OFF	6
ON	ON	ON	OFF	OFF	OFF	OFF	OFF	OFF	OFF	7
...	...	...	...	...	...	...	...	...	...	...
ON	ON	ON	ON	ON	ON	ON	ON	ON	ON	1023

 <b>WARNING</b>	<p><b>Unique TwinSAFE address</b></p> <p>Each TwinSAFE address may only be used once within a network!                      The address 0 is not a valid TwinSAFE address.</p>
---	--

### 4.2.5 Entering a TwinSAFE address and parameters in the System Manager

The TwinSAFE address set at the DIP switch must also be entered under the *Parameters* tab (*S\_Address* entry).

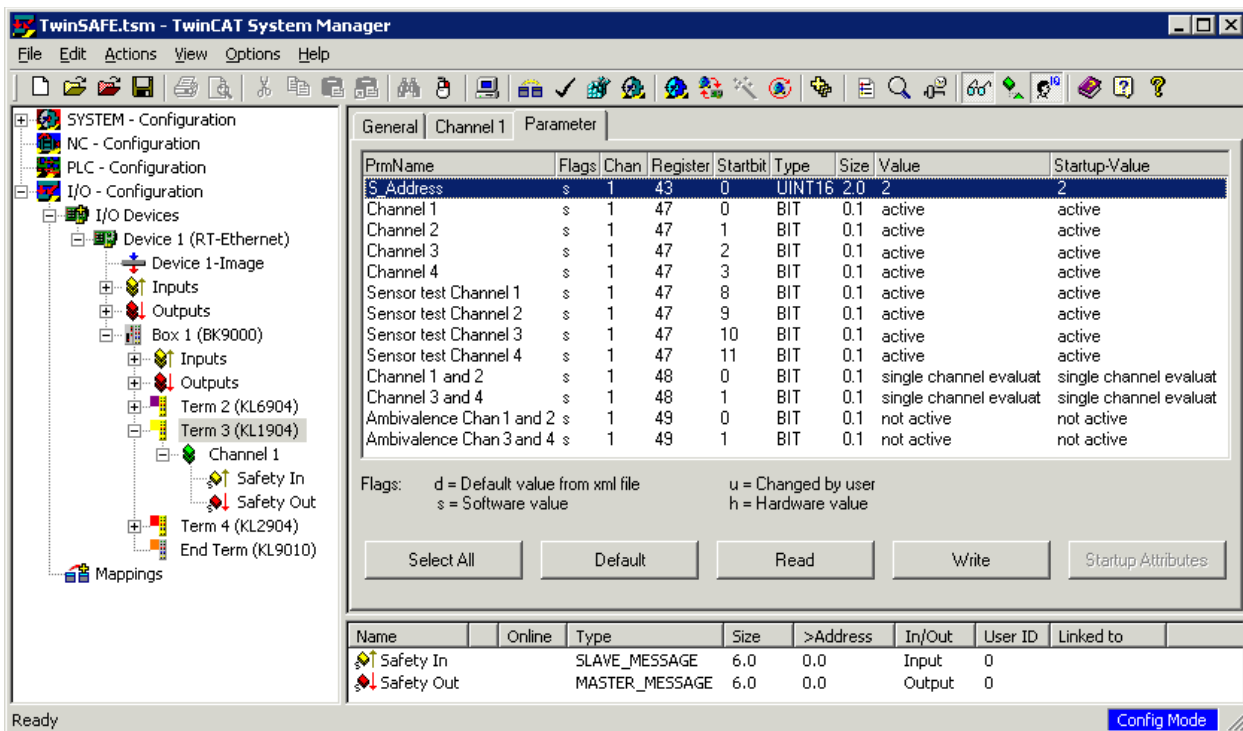

#### Parameter overview

PrmName	Meaning	Values
S_Address	DIP switch address	1 to 1023
Channel 1	Activation of channel 1	active/not active
Channel 2	Activation of channel 2	active/not active
Channel 3	Activation of channel 3	active/not active
Channel 4	Activation of channel 4	active/not active
Sensor test channel 1	The clock signal for connection Input1+ is checked at connection Input1-.	active/not active
Sensor test channel 2	The clock signal for connection Input2+ is checked at connection Input2-.	active/not active
Sensor test channel 3	The clock signal for connection Input3+ is checked at connection Input3-.	active/not active
Sensor test channel 4	The clock signal for connection Input4+ is checked at connection Input4-.	active/not active
Channel 1 and 2	For two-channel evaluation, inputs 1 and 2 must have the same signal states.	single-channel evaluation/two-channel evaluation
Channel 3 and 4	For two-channel evaluation, inputs 3 and 4 must have the same signal states.	single-channel evaluation/two-channel evaluation
Ambivalence Channel 1 and 2	If active, inputs 1 and 2 must have different signal states.	not active/active
Ambivalence Channel 3 and 4	If active, inputs 3 and 4 must have different signal states.	not active/active

4.2.5.1 KL1904 configuration for light barriers, light grids, light curtains etc.

From firmware version 17 the KL1904 also supports direct connection of contact-free protective equipment with two self-testing outputs such as light barriers, light grids, light curtains, laser scanners etc.

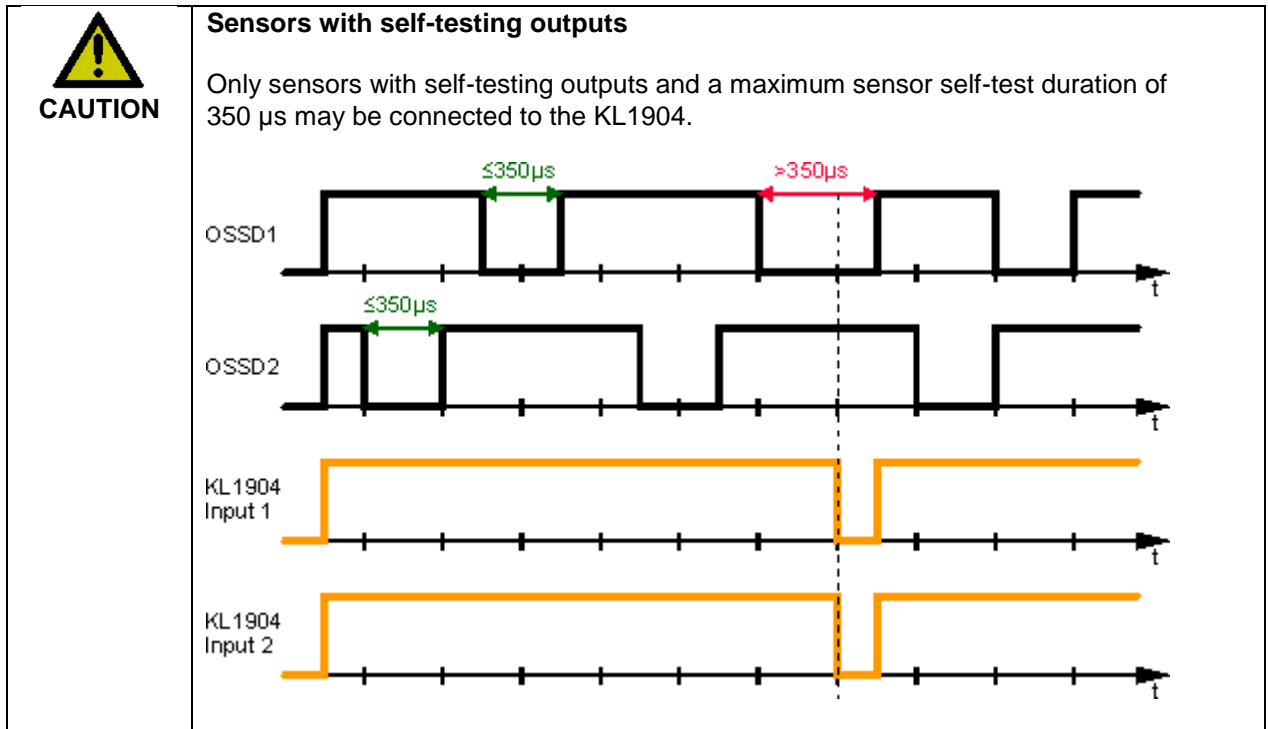

**Parameter**

To connect these sensors please set the following parameters for the KL1904 in the TwinCAT System Manager:

- Connect the two sensor signals either to channels 1 and 2 or channels 3 and 4 and activate the two-channel evaluation for the two inputs used.
- Set the KL1904 sensor test for the two inputs used to *not active*.

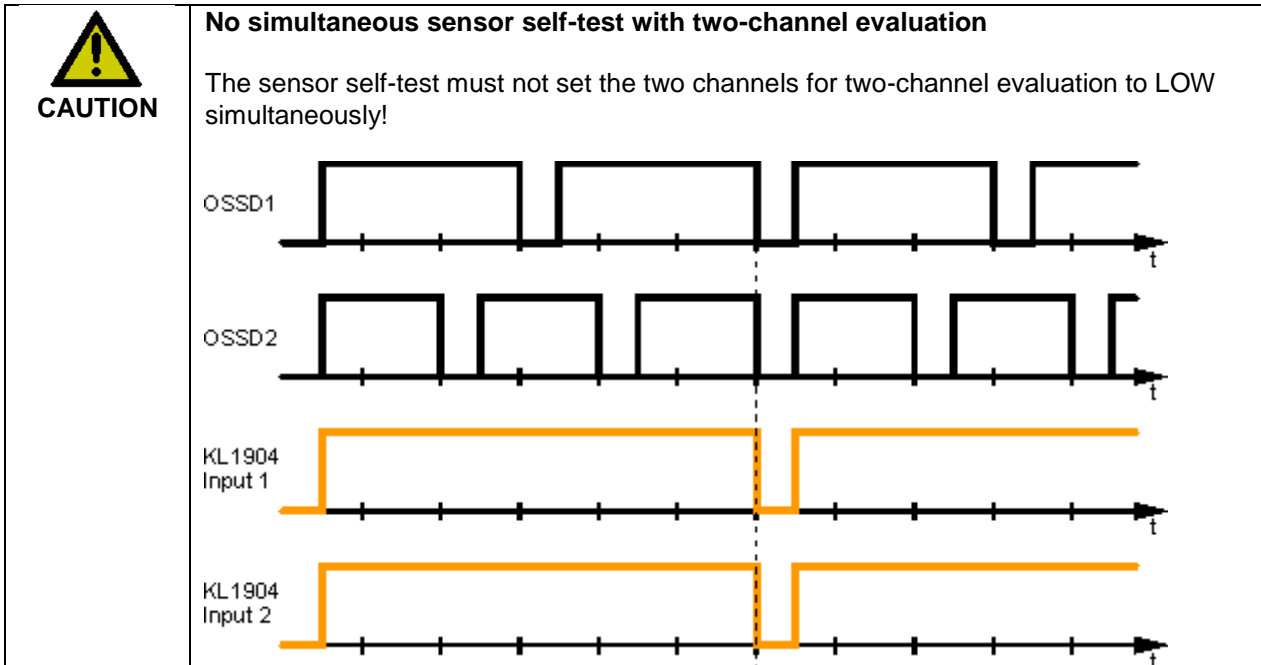

## 4.3 Diagnostics

### 4.3.1 Diagnostic LEDs

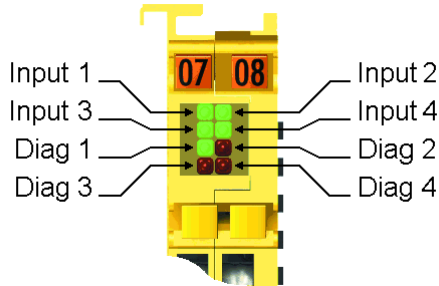

#### 4.3.1.1 Diag 1 (green)

The *Diag 1* LED indicates the state of the TwinSAFE interface.

Flashing Code	Meaning
LED illuminated continuously (from firmware version 17) or cyclic flashing at 1 Hz (up to firmware version 16)	normal operation: TwinSAFE communication OK
rapid flickering, alternating with 1 flash pulse	Error in S parameter (TwinSAFE parameter)
rapid flickering, alternating with 2 flash pulses	Error in I parameter (Individual parameter)
rapid flickering, alternating with 3 flash pulses	Waiting for S and I parameter
rapid flickering, alternating with 4 flash pulses	S- and I-parameter correct: waiting for first host message
rapid flickering, alternating with 5 flash pulses	Watchdog error
rapid flickering, alternating with 6 flash pulses	CRC error
rapid flickering, alternating with 7 flash pulses	Sequence number error
rapid flickering, alternating with 8 flash pulses	Intermediate state in a sensor

#### 4.3.1.2 Diag 2 (red)

The *Diag 2* LED illuminates red if the terminal detects an external supply or cross-circuit. The LED extinguishes once the error is rectified.

### 4.3.1.3 Diag 3 (red) and Diag 4 (red)

The *Diag 3* and *Diag 4* LEDs indicate internal terminal errors.

 <b>Note</b>	<b>Returning the terminal</b>  These errors lead to shutdown of the terminal. The terminal must be checked by Beckhoff Automation GmbH & Co. KG.
--	--

Diag 3 LED (red)	Diag 4 LED (red)	Source of error
lit	flashes (see below for flashing codes)	μC1
lit	off	μC2

In the event of a fault the *Diag 4* LED indicates the type of error through flashing codes. The flashing codes are structured as follows:

Flashing sequence	Meaning
Rapid flickering	Start of flashing code
First slow sequence	Error code
Second slow sequence	Error code argument

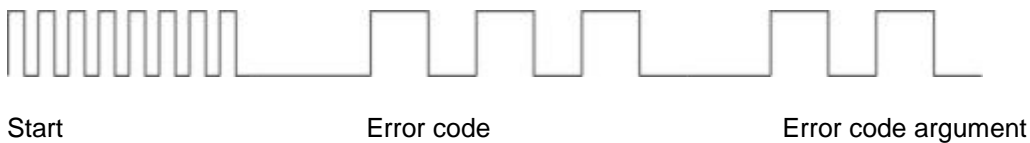

Count the number of flash pulses after the rapid flickering sequence

- during the first slow sequence in order to ascertain the error code
- during the second slow sequence in order to ascertain the error argument

The flashing code is repeated after the second slow sequence, followed by rapid flickering.

## 4.4 Maintenance

The TwinSAFE terminals are maintenance-free!

 <b>WARNING</b>	<p><b>Observe the specified environmental conditions!</b></p> <p>Please ensure that the TwinSAFE terminals are only stored and operated under the specified conditions (see technical data).</p>
---	--

If the terminal is operated outside the permitted temperature range it will switch to *Global Fault* state.

### 4.4.1 Cleaning

Protect the TwinSAFE terminal from unacceptable soiling during operation and storage!

If the TwinSAFE terminals were subjected to unacceptable soiling they may no longer be operated!

 <b>WARNING</b>	<p><b>Have soiled terminals checked!</b></p> <p>Cleaning of the TwinSAFE terminal by the user is not permitted! Please send soiled terminals to the manufacturer for inspection and cleaning!</p>
---	---

### 4.4.2 Service life

The TwinSAFE terminals are designed for a service life of 20 years.

Due to the high diagnostic coverage within the lifecycle no special proof tests are required.

The TwinSAFE terminals bear a date code, which is composed as follows:

Date Code: CW YY SW HW

Legend:

CW: Calendar week of manufacture  
 YY: Year of manufacture  
 SW: Software version  
 HW: Hardware version

Example: Date Code 17 11 05 00  
 Calendar week: 17  
 Year: 2011  
 Software version: 05  
 Hardware version: 00

In addition the TwinSAFE terminals bear a unique serial number.

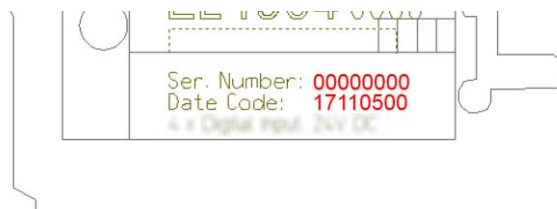

## 4.5 Decommissioning

 <b>DANGER</b>	<b>Serious risk of injury!</b> Bring the bus system into a safe, de-energized state before starting disassembly of the Bus Terminals!
--	--

### 4.5.1 Disposal

In order to dispose of the device, it must be removed and fully dismantled.

- Housing components (polycarbonate, polyamide (PA6.6)) are suitable for plastic recycling.
- Metal parts can be sent for metal recycling.
- Electronic parts such as disk drives and circuit boards must be disposed of in accordance with national electronics scrap regulations.

## 5 Appendix

### 5.1 Beckhoff Support and Service

Beckhoff and their partners around the world offer comprehensive support and service, making available fast and competent assistance with all questions related to Beckhoff products and system solutions.

#### 5.1.1 Beckhoff branches and partner companies Beckhoff Support

Please contact your Beckhoff branch office or partner company for [local support and service](#) on Beckhoff products!

The contact addresses for your country can be found in the list of Beckhoff branches and partner companies: [www.beckhoff.com](http://www.beckhoff.com). You will also find further [documentation](#) for Beckhoff components there.

#### 5.1.2 Beckhoff company headquarters

Beckhoff Automation GmbH & Co.KG  
Huelshorstweg 20  
33415 Verl  
Germany

Phone: + 49 (0) 5246/963-0  
Fax: + 49 (0) 5246/963-198  
E-mail: [info@beckhoff.com](mailto:info@beckhoff.com)  
Web: [www.beckhoff.com](http://www.beckhoff.com)

##### Beckhoff Support

Support offers you comprehensive technical assistance, helping you not only with the application of individual Beckhoff products, but also with other, wide-ranging services:

- world-wide support
- design, programming and commissioning of complex automation systems
- and extensive training program for Beckhoff system components

Hotline: + 49 (0) 5246/963-157  
Fax: + 49 (0) 5246/963-9157  
E-mail: [support@beckhoff.com](mailto:support@beckhoff.com)

##### Beckhoff Service

The Beckhoff Service Center supports you in all matters of after-sales service:

- on-site service
- repair service
- spare parts service
- hotline service

Hotline: + 49 (0) 5246/963-460  
Fax: + 49 (0) 5246/963-479  
E-mail: [service@beckhoff.com](mailto:service@beckhoff.com)

## 5.2 Certificates

BECKHOFF New Automation Technology

Reliability of KL 1904

### Reliability of KL1904

#### Test and Certification body

TÜV SÜD Rail GmbH  
 Rail Automation - IQSE  
 Barthstraße 16  
 D-80339 Munich



#### Manufacturer

Beckhoff Automation GmbH & Co. KG  
 Huelshorstweg 20  
 D-33415 Verl

#### Safety parameters KL1904

Key figures	KL1904
Lifetime [a]	20
Prooftest Intervall [a]	not required <sup>1)</sup>
PFH <sub>D</sub>	2.30E-09
%SIL3	2.30%
PFD	1.81E-04
%SIL3	18.1%
MTTF <sub>d</sub>	High
B10d (cycles)	-
DC	High
Performance level	PL e
Category	4
HFT	1
Element classification*	Type B

\*) Classification according to IEC 61508-2:2010 (see chapters 7.4.4.1.2 and 7.4.4.1.3)

The KL1904 Bus Terminal can be used for safety-related applications within the meaning of IEC 61508:2010 up to SIL3 and EN ISO 13849-1 up to PL e (Cat4).

<sup>1)</sup> Special proof tests for the product are not required during the lifetime of the KL1904 Bus terminal as a result of the high diagnostic coverage of the system.

Munich, 2016-03-07

Günter Greil

Digital unterschrieben von  
 Günter Greil  
 DN: c=DE, o=TÜV SÜD Rail  
 GmbH, ou=Rail & Automation,  
 cn=Günter Greil,  
 email=günter.greil@tuv-  
 sud.de  
 Datum: 2016.03.07 17:51:39  
 +01'00'

TwinSAFE Reliability

9

ZERTIFIKAT ◆ CERTIFICATE ◆ 認証証書 ◆ CERTIFICADO ◆ CERTIFICAT

AT / 04-11



Product Service

# CERTIFICATE

No. Z10 14 12 62386 023

**Holder of Certificate:** Beckhoff Automation GmbH & Co. KG  
 Hülshorstweg 20  
 33415 Verl  
 GERMANY

**Factory(ies):** 62386

**Certification Mark:**



**Product:** Safety components

**Model(s):** KL 1904, EL 1904

**Parameters:**  
 Supply voltage: 24VDC (-15%/+20%)  
 Power dissipation: 540mW  
 Protection class: IP 20

**Tested according to:**  
 2006/42/EC  
 EN 61508-1:2010 (SIL 1-3)  
 EN 61508-2:2010 (SIL 1-3)  
 EN 61508-3:2010 (SIL 1-3)  
 DIN EN ISO 13849-1:2008 (Cat 4, PL e)  
 DIN EN 81-1:2000  
 EN 13243:2004  
 DIN EN 61000-6-2:2006  
 DIN EN 61000-6-4:2007

The product was tested on a voluntary basis and complies with the essential requirements. The certification mark shown above can be affixed on the product. It is not permitted to alter the certification mark in any way. In addition the certification holder must not transfer the certificate to third parties. See also notes overleaf.

**Test report no.:** BV82168T

**Valid until:** 2019-12-17

**Date,** 2014-12-18

( Günter Greil )

Page 1 of 1



TÜV SÜD Product Service GmbH · Zertifizierstelle · Ridlerstraße 65 · 80339 München · Germany

TÜV®