

Documentation

KL2502, KL2512

Dual Channel Pulse Width Output Terminals, 24 V DC

Version: 4.1
Date: 2019-02-05

BECKHOFF

Table of contents

| | |
|--|-----------|
| 1 Foreword | 5 |
| 1.1 Notes on the documentation..... | 5 |
| 1.2 Safety instructions | 6 |
| 1.3 Documentation issue status | 7 |
| 2 Product overview | 8 |
| 2.1 KL2502 - Introduction | 8 |
| 2.2 KL2512 - Introduction | 9 |
| 2.3 KL2502, KL2512 - Technical data | 10 |
| 2.4 Basic Function Principles | 10 |
| 2.5 Operation modes | 11 |
| 3 Mounting and wiring | 13 |
| 3.1 Instructions for ESD protection | 13 |
| 3.2 Installation on mounting rails | 13 |
| 3.3 Connection | 17 |
| 3.3.1 Connection system | 17 |
| 3.3.2 Wiring..... | 18 |
| 3.3.3 Shielding | 20 |
| 3.4 KL2502, KL2512 - Connection and LED description | 21 |
| 3.5 ATEX - Special conditions (standard temperature range)..... | 22 |
| 3.6 ATEX Documentation | 23 |
| 4 Configuration Software KS2000 | 24 |
| 4.1 KS2000 - Introduction..... | 24 |
| 5 Access from the user program | 26 |
| 5.1 Terminal configuration | 26 |
| 5.2 Mapping in the Bus Coupler | 27 |
| 5.2.1 KL2502 | 27 |
| 5.3 Register overview | 29 |
| 5.4 Register description | 30 |
| 5.5 Control and status byte..... | 33 |
| 5.5.1 Register communication | 33 |
| 5.6 Examples of Register Communication | 34 |
| 5.6.1 Example 1: reading the firmware version from Register 9..... | 34 |
| 5.6.2 Example 2: Writing to an user register..... | 35 |
| 6 Appendix | 38 |
| 6.1 Support and Service | 38 |

1 Foreword

1.1 Notes on the documentation

Intended audience

This description is only intended for the use of trained specialists in control and automation engineering who are familiar with the applicable national standards.

It is essential that the documentation and the following notes and explanations are followed when installing and commissioning these components.

It is the duty of the technical personnel to use the documentation published at the respective time of each installation and commissioning.

The responsible staff must ensure that the application or use of the products described satisfy all the requirements for safety, including all the relevant laws, regulations, guidelines and standards.

Disclaimer

The documentation has been prepared with care. The products described are, however, constantly under development.

We reserve the right to revise and change the documentation at any time and without prior announcement.

No claims for the modification of products that have already been supplied may be made on the basis of the data, diagrams and descriptions in this documentation.

Trademarks

Beckhoff®, TwinCAT®, EtherCAT®, EtherCAT P®, Safety over EtherCAT®, TwinSAFE®, XFC® and XTS® are registered trademarks of and licensed by Beckhoff Automation GmbH.

Other designations used in this publication may be trademarks whose use by third parties for their own purposes could violate the rights of the owners.

Patent Pending

The EtherCAT Technology is covered, including but not limited to the following patent applications and patents: EP1590927, EP1789857, DE102004044764, DE102007017835 with corresponding applications or registrations in various other countries.

The TwinCAT Technology is covered, including but not limited to the following patent applications and patents: EP0851348, US6167425 with corresponding applications or registrations in various other countries.

The logo for EtherCAT, featuring the word "EtherCAT" in a bold, black, sans-serif font. A red arrow points from the top of the "A" towards the right, ending above the "T". A registered trademark symbol (®) is located to the right of the "T".

EtherCAT® is registered trademark and patented technology, licensed by Beckhoff Automation GmbH, Germany.

Copyright

© Beckhoff Automation GmbH & Co. KG, Germany.

The reproduction, distribution and utilization of this document as well as the communication of its contents to others without express authorization are prohibited.

Offenders will be held liable for the payment of damages. All rights reserved in the event of the grant of a patent, utility model or design.

1.2 Safety instructions

Safety regulations

Please note the following safety instructions and explanations!
Product-specific safety instructions can be found on following pages or in the areas mounting, wiring, commissioning etc.

Exclusion of liability

All the components are supplied in particular hardware and software configurations appropriate for the application. Modifications to hardware or software configurations other than those described in the documentation are not permitted, and nullify the liability of Beckhoff Automation GmbH & Co. KG.

Personnel qualification

This description is only intended for trained specialists in control, automation and drive engineering who are familiar with the applicable national standards.

Description of instructions

In this documentation the following instructions are used.
These instructions must be read carefully and followed without fail!

DANGER

Serious risk of injury!

Failure to follow this safety instruction directly endangers the life and health of persons.

WARNING

Risk of injury!

Failure to follow this safety instruction endangers the life and health of persons.

CAUTION

Personal injuries!

Failure to follow this safety instruction can lead to injuries to persons.

NOTE

Damage to environment/equipment or data loss

Failure to follow this instruction can lead to environmental damage, equipment damage or data loss.



Tip or pointer

This symbol indicates information that contributes to better understanding.

1.3 Documentation issue status

| Version | Comment |
|---------|--|
| 4.1 | <ul style="list-style-type: none"> • Structure update • Technical data updated • Revision status updated |
| 4.0 | <ul style="list-style-type: none"> • Migration • Structure update • Technical data updated • Revision status updated |

Firmware and hardware versions

| Documentation Version | KL2502 | | KL2512 | |
|-----------------------|----------|----------|----------|----------|
| | Firmware | Firmware | Firmware | Hardware |
| 4.1 | 3F | 08 | 3F | 02 |
| 4.0 | 3F | 08 | 3F | 02 |

The firmware and hardware versions (delivery state) of the terminal can be found in the serial number printed on the side.

Syntax of the serial number

Structure of the serial number: WW YY FF HH

- WW - week of production (calendar week)
- YY – year of production
- FF - firmware version
- HH - hardware version

Example with ser. No.: 12 06 3A 02:

- 12 - week of production 12
- 06 - year of production 2006
- 3A - firmware version 3A
- 02 - hardware version 02

2 Product overview

2.1 KL2502 - Introduction

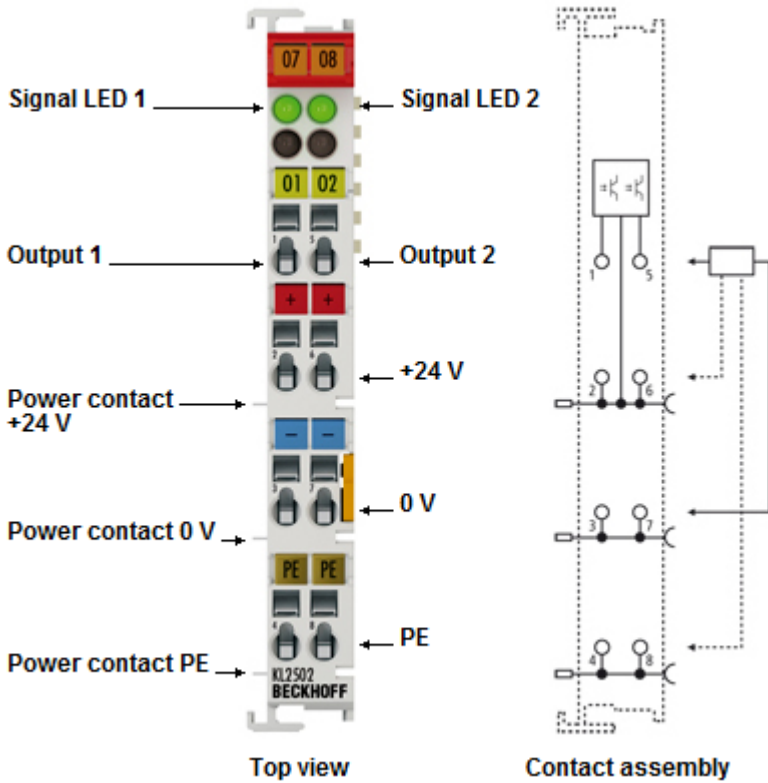

Fig. 1: KL2502

Two-channel pulse width output terminal 24 V DC, positive switching

The KL2502 output terminal modulates the pulse width of a binary signal, and outputs it electrically isolated from the K-bus. The mark/space ratio is prescribed by a 16 bit value from the automation device. The output stage is protected against overload and short-circuit. The Bus Terminal contains two channels that indicate its signal state by means of light emitting diodes. The LEDs are driven in time with the outputs, and show the duty factor by their brightness.

2.2 KL2512 - Introduction

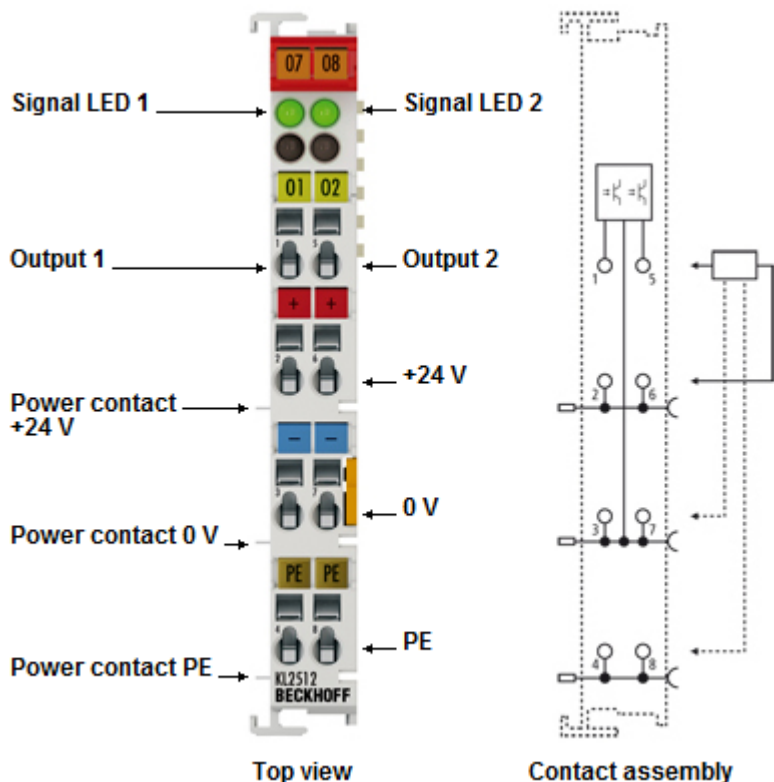

Fig. 2: KL2512

Two-channel pulse width output terminal 24 V DC, negative switching

The KL2512 Bus Terminal enables direct connection of different ohmic loads. The output signal is a pulse-width modulated voltage. The typical load of an LED group or an incandescent lamp is connected between the positive side of the supply voltage and the output of the KL2512. Via the fieldbus the output can be set independently for two channels with a resolution of more than 30,000 steps. The PWM frequency can be changed. The power transistors switch the ground connection and are electrically isolated from the internal K-bus.

2.3 KL2502, KL2512 - Technical data

| Technical data | KL2502 | KL2512 |
|--|---|---------------------------------|
| Number of outputs | 2 | |
| Rated load voltage | 24 V _{DC} (20 V...29 V) | |
| Connected potential | 24 V | 0 V |
| Load type | Resistive, inductive | resistive |
| Max. output current (per channel) | 0.1 A (short-circuit proof, 1 A driver component) | 1.5 A |
| Base frequency | 1 ... 20 kHz, default: 250 Hz | |
| Duty factor | 0...100 % (T _{ON} > 750 ns, T _{OFF} > 500 ns) | 0...100 % |
| Resolution | max. 10 bit | |
| Electrical isolation | 500 V (K-bus/field voltage) | |
| Current consumption from the K-bus | typ. 18 mA | |
| Load voltage current consumption | typ. 10 mA | |
| Bit width in process image | 48 I/O: 2 x 16 bit data (2 x 8 bit control/status) | |
| Configuration | No address setting, configuration via the Bus Coupler or the controller | |
| Weight | approx. 50 g | |
| Permissible ambient temperature range during operation | 0 °C ... + 55°C | |
| Permissible ambient temperature range during storage | -25 °C ... + 85°C | |
| Permissible relative air humidity | 95 %, no condensation | |
| Dimensions (H x W x D) | approx. 15 mm x 100 mm x 70 mm (width aligned: 12 mm) | |
| Mounting ▶ 13 | on 35 mm mounting rail according to EN 60715 | |
| Vibration / shock resistance | conforms to EN 60068-2-6 / EN 60068-2-27 | |
| EMC immunity / emission | conforms to EN 61000-6-2 / EN 61000-6-4 | |
| Protection class | IP20 | |
| Installation position | variable | |
| Approval | CE ATEX ▶ 22 IECEX cULus | CE ATEX ▶ 22 |

2.4 Basic Function Principles

The KL2502 output terminal modulates the pulse width of a binary signal. The peripheral side of the electronics is electrically isolated from the internal K-bus, and therefore also from the fieldbus. The cycle (base frequency) and the pulse/pause ratio are configurable. 16-bit values can be specified for setting purposes via the process image of the controller.

In the delivery state the KL2502 terminal occupies 6 bytes in the process image. The mapping of the KL2502 can be set by means of the controller or by the Bus Coupler's configuration interface using the Beckhoff KS2000 configuration software.

In addition to PWM mode, the KL2502 can also be operated in FM mode (frequency modulation), or with pulse direction setting for stepper motor control (Frq-Cnt pulse mode).

The default setting of the terminal in delivery state is PWM mode with a base frequency of 250 Hz and a resolution of 10 bit.

The LEDs indicate the operating state of the associated terminal channels.

- green Run LED:
 - On: normal operation
 - Off: Watchdog timer overflow has occurred. If no process data are transmitted by the Bus Coupler for 100 ms, the green LEDs go out. The output assumes a user-specified voltage (see Feature register).

Process data

Input format:

KL2502: Two's complement representation (integer -1 corresponds to 0xFFFF)
 The ratio of duty cycle/period is specified with a maximum resolution of 10 bit.

KL2512: 16 bit unsigned integer

| Output value | Process data | | |
|------------------|--------------------------------|--------------------------------|--------------------------------|
| | KL2502 | KL2512* | |
| 0 % Duty Cycle | 0x0000 (0 _{dec}) | 0x7FFF (32767 _{dec}) | 0xFFFF (65535 _{dec}) |
| 50 % Duty Cycle | 0x3FFF (16383 _{dec}) | 0x3FFF (16383 _{dec}) | 0xBFFF (49151 _{dec}) |
| 100 % Duty Cycle | 0x7FFF (32767 _{dec}) | 0x0000 (0 _{dec}) | 0x8000 (32768 _{dec}) |

*) The KL2512 passes through the output values (0...100 % duty cycle) twice.

2.5 Operation modes

The operating mode of the terminal is set via feature register [R32 \[► 32\]](#).

PWM mode

2 channels can be operated in the PWMx modes. Note that the operating mode and the cycle duration for both channels are identical.

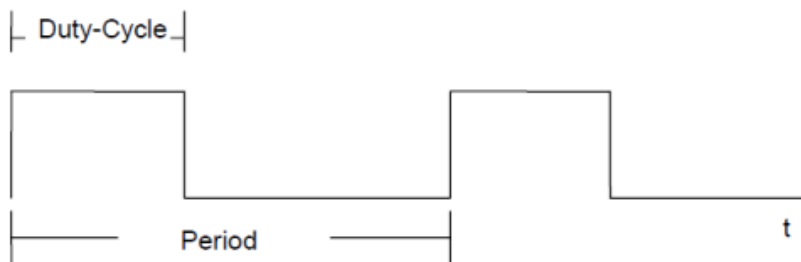

PWMH

In PWM mode, the ratio of duty cycle to cycle duration is determined by the process data.

100 % duty cycle corresponds to process record 0x7FFF. The cycle duration can be specified during operation via register [R2 \[► 30\]](#). It is loaded after a system start-up from register [R35 \[► 32\]](#) (SEEROM) and entered into R2.

The frequency range covers 245 Hz to 20 kHz (0xFA0 in R2 corresponds to 250 Hz) with a resolution of 10 bit at 245 Hz, 976 Hz and 3.9 kHz.

PWML

In PWM mode, the ratio of duty cycle to cycle duration is determined by the process data. 100 % duty cycle corresponds to process record 0x7FFF (32767). The cycle duration can be specified during operation via register [R2 \[► 30\]](#). It is loaded after a system start-up from register [R35 \[► 32\]](#) (SEEROM) and entered into R2.

The frequency range is from 2 Hz to 250 Hz (250 Hz corresponds to 0x01F4 in R2).

Frq-Cnt PWM mode

The frequency is specified in 2 Hz per digit via the process output data of the control. The controller receives the number of periods that are output by the terminal as process input data. In this operating mode, the count direction is determined via the sign of the output data. 2 Hz corresponds to the value 0x0001, -2 Hz

corresponds to the value 0xFFFF (signed integer). The frequency range is 2 Hz to 2 kHz. The pulses are issued at output A1, the count direction at output A2. *Down* corresponds to signal level GND, *up* corresponds to signal level Vcc (24 V).

With rising edge of control bit 0 the counter is set to the value of the output data (control byte in process data mode, i.e. bit 7=0).

The pulse width ratio is specified via [R36](#) [[▶ 32](#)].

Frq-Cnt pulse mode

The frequency is specified in 2 Hz per digit via the process output data of the control. The controller receives the number of pulses that are output by the terminal as process input data. In this operating mode, the count direction is determined via the sign of the output data. 2 Hz corresponds to the value 0x0001, -2 Hz corresponds to the value 0xFFFF (signed integer). The pulses are issued at output A1, the count direction at output A2. *Down* corresponds to signal level GND, *up* corresponds to signal level Vcc. The frequency range is 2 Hz to 2 kHz.

With rising edge of control bit 0 the counter is set to the value of the output data. (Control byte in process data mode, i.e. bit7=0).

The pulse width is fixed for all frequencies and is specified via [R37](#) [[▶ 32](#)].

Cnt-Cnt PWM mode

The number of pulses is specified via the process output data. The controller receives the number of output periods as process input data. The pulse width ratio is specified via [R36](#) [[▶ 32](#)], the cycle duration via [R35](#) [[▶ 32](#)]. The output is started with a positive edge of control bit 0. It can be triggered with each additional edge. The pulses are issued at output A1, output A2 can be set via control bit 2. In status bit 0 the controller receives the transfer and the simultaneous start of the pulse output as status information. Status bit 1 remains set as long as the output is active and status bit 2 returns the status of channel 1.

3 Mounting and wiring

3.1 Instructions for ESD protection

NOTE

Destruction of the devices by electrostatic discharge possible!

The devices contain components at risk from electrostatic discharge caused by improper handling.

- Please ensure you are electrostatically discharged and avoid touching the contacts of the device directly.
- Avoid contact with highly insulating materials (synthetic fibers, plastic film etc.).
- Surroundings (working place, packaging and personnel) should be grounded probably, when handling with the devices.
- Each assembly must be terminated at the right hand end with an [EL9011](#) or [EL9012](#) bus end cap, to ensure the protection class and ESD protection.

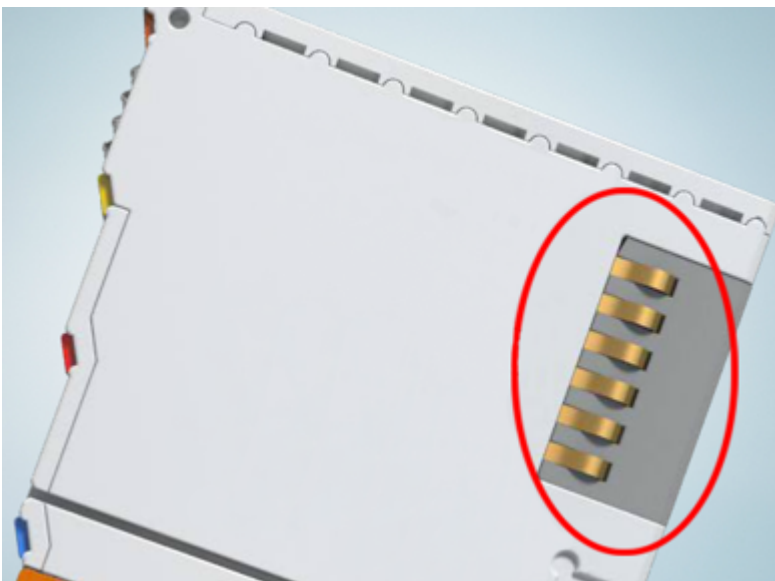

Fig. 3: Spring contacts of the Beckhoff I/O components

3.2 Installation on mounting rails

⚠ WARNING

Risk of electric shock and damage of device!

Bring the bus terminal system into a safe, powered down state before starting installation, disassembly or wiring of the bus terminals!

Assembly

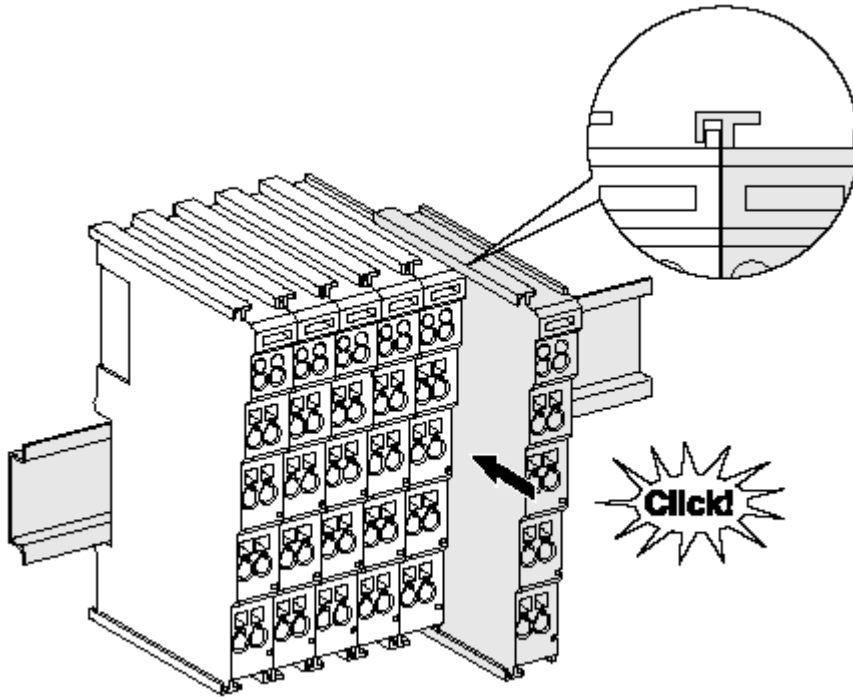

Fig. 4: Attaching on mounting rail

The bus coupler and bus terminals are attached to commercially available 35 mm mounting rails (DIN rails according to EN 60715) by applying slight pressure:

1. First attach the fieldbus coupler to the mounting rail.
2. The bus terminals are now attached on the right-hand side of the fieldbus coupler. Join the components with tongue and groove and push the terminals against the mounting rail, until the lock clicks onto the mounting rail.

If the terminals are clipped onto the mounting rail first and then pushed together without tongue and groove, the connection will not be operational! When correctly assembled, no significant gap should be visible between the housings.

i Fixing of mounting rails

The locking mechanism of the terminals and couplers extends to the profile of the mounting rail. At the installation, the locking mechanism of the components must not come into conflict with the fixing bolts of the mounting rail. To mount the mounting rails with a height of 7.5 mm under the terminals and couplers, you should use flat mounting connections (e.g. countersunk screws or blind rivets).

Disassembly

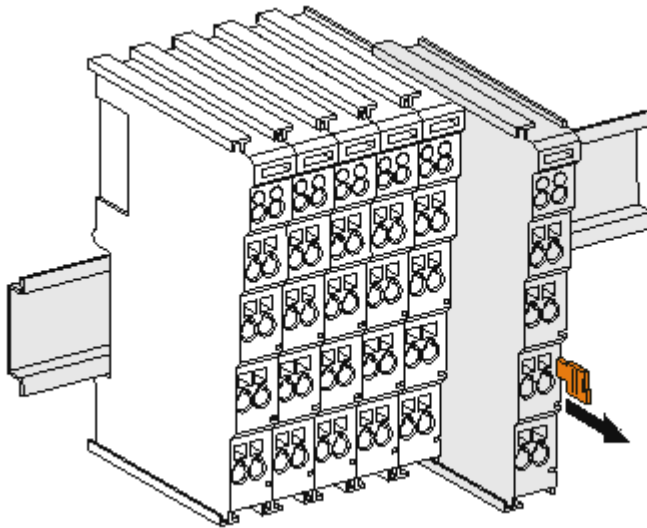

Fig. 5: Disassembling of terminal

Each terminal is secured by a lock on the mounting rail, which must be released for disassembly:

1. Pull the terminal by its orange-colored lugs approximately 1 cm away from the mounting rail. In doing so for this terminal the mounting rail lock is released automatically and you can pull the terminal out of the bus terminal block easily without excessive force.
2. Grasp the released terminal with thumb and index finger simultaneous at the upper and lower grooved housing surfaces and pull the terminal out of the bus terminal block.

Connections within a bus terminal block

The electric connections between the Bus Coupler and the Bus Terminals are automatically realized by joining the components:

- The six spring contacts of the K-Bus/E-Bus deal with the transfer of the data and the supply of the Bus Terminal electronics.
- The power contacts deal with the supply for the field electronics and thus represent a supply rail within the bus terminal block. The power contacts are supplied via terminals on the Bus Coupler (up to 24 V) or for higher voltages via power feed terminals.

● Power Contacts

i During the design of a bus terminal block, the pin assignment of the individual Bus Terminals must be taken account of, since some types (e.g. analog Bus Terminals or digital 4-channel Bus Terminals) do not or not fully loop through the power contacts. Power Feed Terminals (KL91xx, KL92xx or EL91xx, EL92xx) interrupt the power contacts and thus represent the start of a new supply rail.

PE power contact

The power contact labeled PE can be used as a protective earth. For safety reasons this contact mates first when plugging together, and can ground short-circuit currents of up to 125 A.

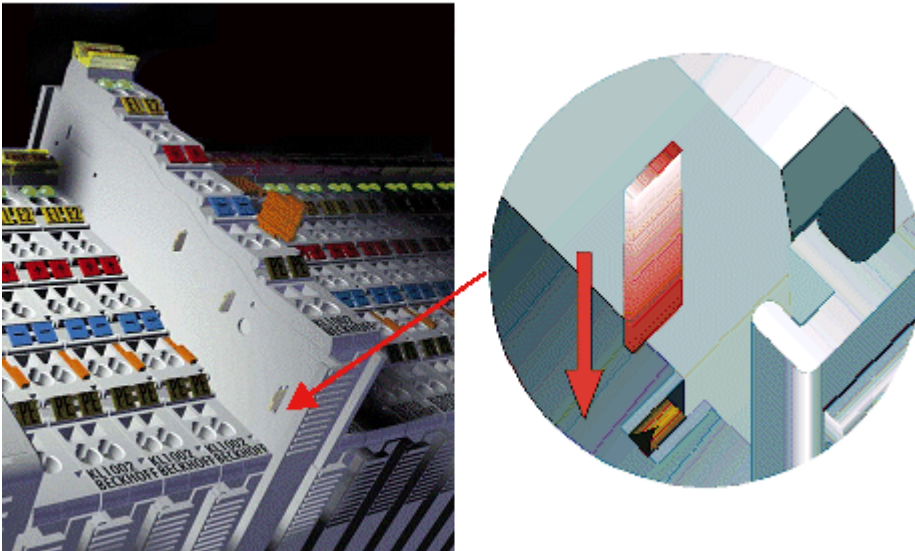

Fig. 6: Power contact on left side

NOTE

Possible damage of the device

Note that, for reasons of electromagnetic compatibility, the PE contacts are capacitatively coupled to the mounting rail. This may lead to incorrect results during insulation testing or to damage on the terminal (e.g. disruptive discharge to the PE line during insulation testing of a consumer with a nominal voltage of 230 V). For insulation testing, disconnect the PE supply line at the Bus Coupler or the Power Feed Terminal! In order to decouple further feed points for testing, these Power Feed Terminals can be released and pulled at least 10 mm from the group of terminals.

⚠ WARNING

Risk of electric shock!

The PE power contact must not be used for other potentials!

3.3 Connection

3.3.1 Connection system

⚠ WARNING

Risk of electric shock and damage of device!

Bring the bus terminal system into a safe, powered down state before starting installation, disassembly or wiring of the bus terminals!

Overview

The Bus Terminal system offers different connection options for optimum adaptation to the respective application:

- The terminals of ELxxxx and KLxxxx series with standard wiring include electronics and connection level in a single enclosure.
- The terminals of ESxxxx and KSxxxx series feature a pluggable connection level and enable steady wiring while replacing.
- The High Density Terminals (HD Terminals) include electronics and connection level in a single enclosure and have advanced packaging density.

Standard wiring (ELxxxx / KLxxxx)



Fig. 7: Standard wiring

The terminals of ELxxxx and KLxxxx series have been tried and tested for years. They feature integrated screwless spring force technology for fast and simple assembly.

Pluggable wiring (ESxxxx / KSxxxx)



Fig. 8: Pluggable wiring

The terminals of ESxxxx and KSxxxx series feature a pluggable connection level. The assembly and wiring procedure is the same as for the ELxxxx and KLxxxx series. The pluggable connection level enables the complete wiring to be removed as a plug connector from the top of the housing for servicing. The lower section can be removed from the terminal block by pulling the unlocking tab. Insert the new component and plug in the connector with the wiring. This reduces the installation time and eliminates the risk of wires being mixed up.

The familiar dimensions of the terminal only had to be changed slightly. The new connector adds about 3 mm. The maximum height of the terminal remains unchanged.

A tab for strain relief of the cable simplifies assembly in many applications and prevents tangling of individual connection wires when the connector is removed.

Conductor cross sections between 0.08 mm² and 2.5 mm² can continue to be used with the proven spring force technology.

The overview and nomenclature of the product names for ESxxxx and KSxxxx series has been retained as known from ELxxxx and KLxxxx series.

High Density Terminals (HD Terminals)



Fig. 9: High Density Terminals

The Bus Terminals from these series with 16 terminal points are distinguished by a particularly compact design, as the packaging density is twice as large as that of the standard 12 mm Bus Terminals. Massive conductors and conductors with a wire end sleeve can be inserted directly into the spring loaded terminal point without tools.

● Wiring HD Terminals

i The High Density (HD) Terminals of the ELx8xx and KLx8xx series doesn't support pluggable wiring.

Ultrasonically "bonded" (ultrasonically welded) conductors

● Ultrasonically "bonded" conductors

i It is also possible to connect the Standard and High Density Terminals with ultrasonically "bonded" (ultrasonically welded) conductors. In this case, please note the tables concerning the wire-size width below!

3.3.2 Wiring

⚠ WARNING

Risk of electric shock and damage of device!

Bring the bus terminal system into a safe, powered down state before starting installation, disassembly or wiring of the Bus Terminals!

Terminals for standard wiring ELxxxx/KLxxxx and for pluggable wiring ESxxxx/KSxxxx

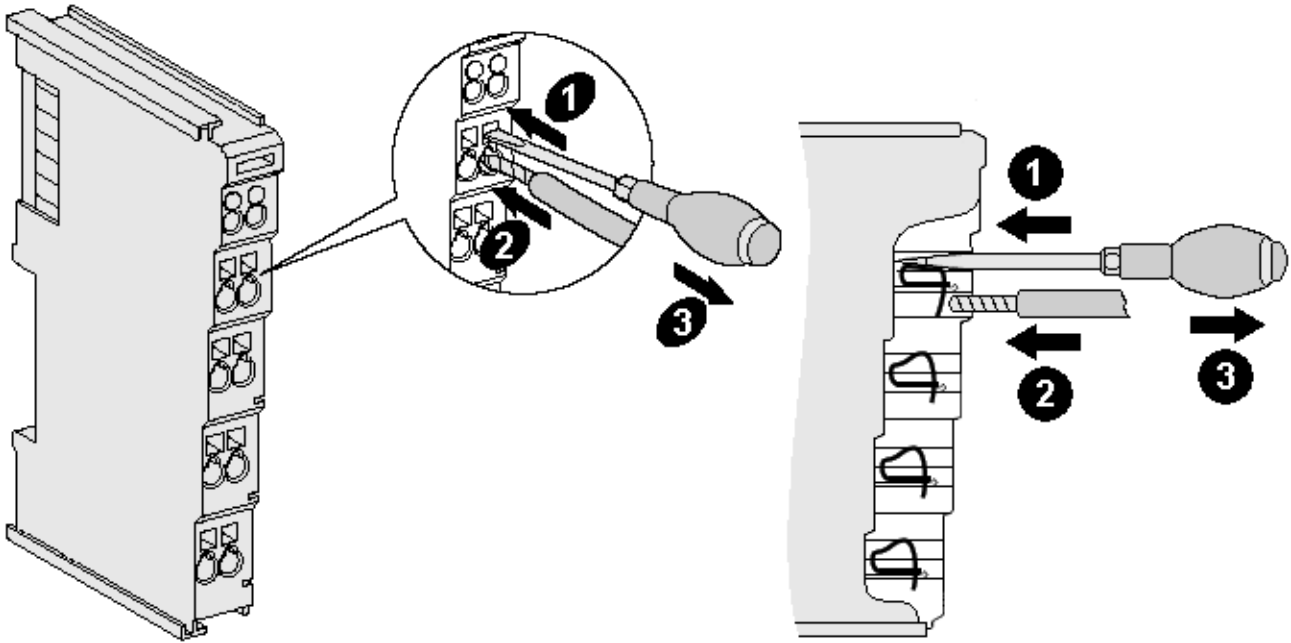

Fig. 10: Connecting a cable on a terminal point

Up to eight terminal points enable the connection of solid or finely stranded cables to the Bus Terminal. The terminal points are implemented in spring force technology. Connect the cables as follows:

1. Open a terminal point by pushing a screwdriver straight against the stop into the square opening above the terminal point. Do not turn the screwdriver or move it alternately (don't toggle).
2. The wire can now be inserted into the round terminal opening without any force.
3. The terminal point closes automatically when the pressure is released, holding the wire securely and permanently.

See the following table for the suitable wire size width.

| Terminal housing | ELxxxx, KLxxxx | ESxxxx, KSxxxx |
|---|------------------------------|------------------------------|
| Wire size width (single core wires) | 0.08 ... 2.5 mm ² | 0.08 ... 2.5 mm ² |
| Wire size width (fine-wire conductors) | 0.08 ... 2.5 mm ² | 0,08 ... 2.5 mm ² |
| Wire size width (conductors with a wire end sleeve) | 0.14 ... 1.5 mm ² | 0.14 ... 1.5 mm ² |
| Wire stripping length | 8 ... 9 mm | 9 ... 10 mm |

High Density Terminals ([HD Terminals](#) [▶ 18]) with 16 terminal points

The conductors of the HD Terminals are connected without tools for single-wire conductors using the direct plug-in technique, i.e. after stripping the wire is simply plugged into the terminal point. The cables are released, as usual, using the contact release with the aid of a screwdriver. See the following table for the suitable wire size width.

| Terminal housing | High Density Housing |
|--|-------------------------------|
| Wire size width (single core wires) | 0.08 ... 1.5 mm ² |
| Wire size width (fine-wire conductors) | 0.25 ... 1.5 mm ² |
| Wire size width (conductors with a wire end sleeve) | 0.14 ... 0.75 mm ² |
| Wire size width (ultrasonically "bonded" conductors) | only 1.5 mm ² |
| Wire stripping length | 8 ... 9 mm |

3.3.3 Shielding



Shielding

Encoder, analog sensors and actors should always be connected with shielded, twisted paired wires.

3.4 KL2502, KL2512 - Connection and LED description

⚠ WARNING

Risk of injury through electric shock and damage to the device!

Bring the Bus Terminal system into a safe, voltage-free state before starting mounting, disassembly or wiring of the Bus Terminals!

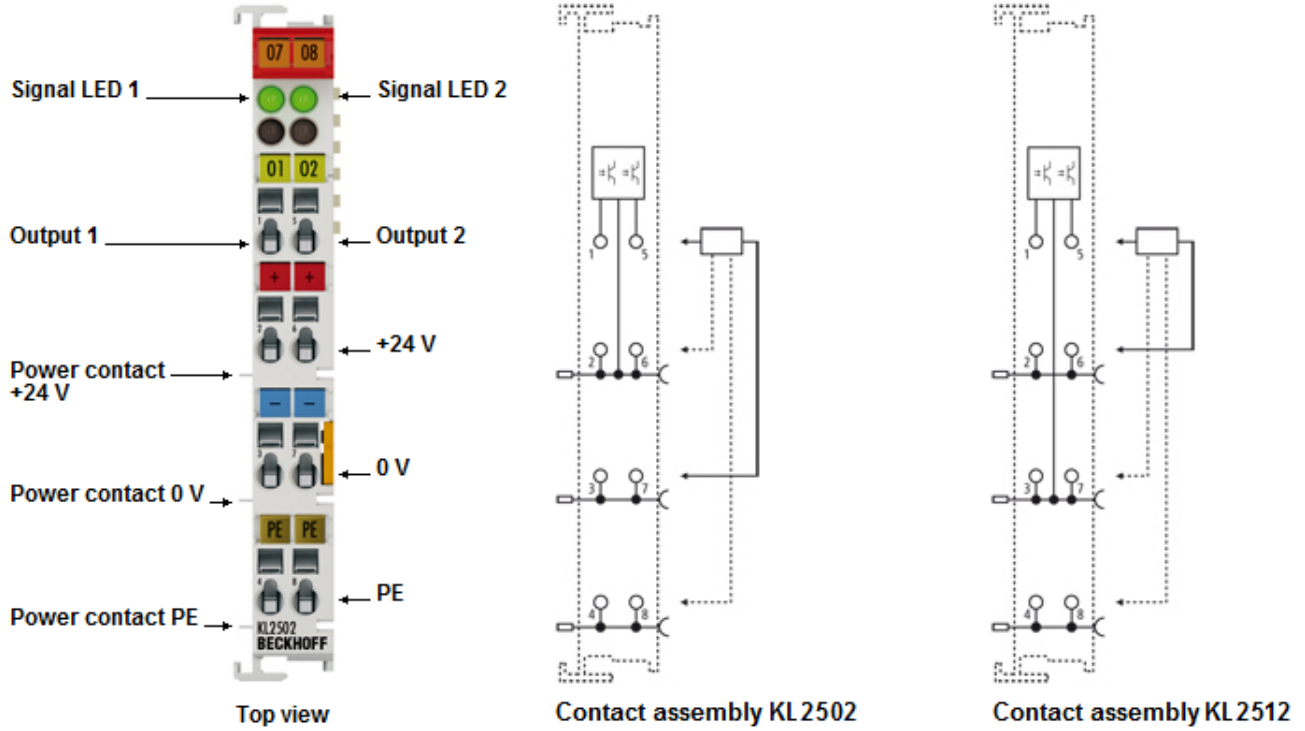

Fig. 11: KL2502, KL2512 - Connection and LEDs

| KL2502, KL2512 connection | | |
|---------------------------|-----|---|
| Terminal point | No. | Comment |
| Output 1 | 1 | Output 1 |
| +24V | 2 | +24 V (internally connected to terminal point 6 and positive power contact) |
| 0V | 3 | 0 V (internally connected to terminal point 7 and negative power contact) |
| PE | 4 | PE connection |
| Output 2 | 5 | Output 2 |
| +24V | 6 | +24 V (internally connected to terminal point 2 and positive power contact) |
| 0V | 7 | 0 V (internally connected to terminal point 3 and negative power contact) |
| PE | 8 | PE connection |

| KL2502, KL2512 LED description | | |
|--------------------------------|-------|--|
| LED | Color | Description |
| Signal LED 1.2 | green | On: normal operation Off: Watchdog timer overflow has occurred. If no process data is transferred from the Bus Coupler for 100 ms, the green LED goes out and the outputs are set to 0% duty cycle. |

3.5 ATEX - Special conditions (standard temperature range)

⚠ WARNING

Observe the special conditions for the intended use of Beckhoff fieldbus components with standard temperature range in potentially explosive areas (directive 94/9/EU)!

- The certified components are to be installed in a suitable housing that guarantees a protection class of at least IP54 in accordance with EN 60529! The environmental conditions during use are thereby to be taken into account!
- If the temperatures during rated operation are higher than 70°C at the feed-in points of cables, lines or pipes, or higher than 80°C at the wire branching points, then cables must be selected whose temperature data correspond to the actual measured temperature values!
- Observe the permissible ambient temperature range of 0 to 55°C for the use of Beckhoff fieldbus components standard temperature range in potentially explosive areas!
- Measures must be taken to protect against the rated operating voltage being exceeded by more than 40% due to short-term interference voltages!
- The individual terminals may only be unplugged or removed from the Bus Terminal system if the supply voltage has been switched off or if a non-explosive atmosphere is ensured!
- The connections of the certified components may only be connected or disconnected if the supply voltage has been switched off or if a non-explosive atmosphere is ensured!
- The fuses of the KL92xx/EL92xx power feed terminals may only be exchanged if the supply voltage has been switched off or if a non-explosive atmosphere is ensured!
- Address selectors and ID switches may only be adjusted if the supply voltage has been switched off or if a non-explosive atmosphere is ensured!

Standards

The fundamental health and safety requirements are fulfilled by compliance with the following standards:

- EN 60079-0:2012+A11:2013
- EN 60079-15:2010

Marking

The Beckhoff fieldbus components with standard temperature range certified for potentially explosive areas bear one of the following markings:



II 3G KEMA 10ATEX0075 X Ex nA IIC T4 Gc Ta: 0 ... 55°C

or



II 3G KEMA 10ATEX0075 X Ex nC IIC T4 Gc Ta: 0 ... 55°C

3.6 ATEX Documentation



Notes about operation of the Beckhoff terminal systems in potentially explosive areas (ATEX)

Pay also attention to the continuative documentation

Notes about operation of the Beckhoff terminal systems in potentially explosive areas (ATEX)

that is available in the download area of the Beckhoff homepage <http://www.beckhoff.com!>

4 Configuration Software KS2000

4.1 KS2000 - Introduction

The KS2000 configuration software permits configuration, commissioning and parameterization of bus couplers, of the affiliated bus terminals and of Fieldbus Box Modules. The connection between bus coupler / Fieldbus Box Module and the PC is established by means of the serial configuration cable or the fieldbus.



Fig. 12: KS2000 configuration software

Configuration

You can configure the Fieldbus stations with the Configuration Software KS2000 offline. That means, setting up a terminal station with all settings on the couplers and terminals resp. the Fieldbus Box Modules can be prepared before the commissioning phase. Later on, this configuration can be transferred to the terminal station in the commissioning phase by means of a download. For documentation purposes, you are provided with the breakdown of the terminal station, a parts list of modules used and a list of the parameters you have modified. After an upload, existing fieldbus stations are at your disposal for further editing.

Parameterization

KS2000 offers simple access to the parameters of a fieldbus station: specific high-level dialogs are available for all bus couplers, all intelligent bus terminals and Fieldbus Box modules with the aid of which settings can be modified easily. Alternatively, you have full access to all internal registers of the bus couplers and intelligent terminals. Refer to the register description for the meanings of the registers.

Commissioning

The KS2000 software facilitates commissioning of machine components or their fieldbus stations: Configured settings can be transferred to the fieldbus modules by means of a download. After a *login* to the terminal station, it is possible to define settings in couplers, terminals and Fieldbus Box modules directly *online*. The same high-level dialogs and register access are available for this purpose as in the configuration phase.

The KS2000 offers access to the process images of the bus couplers and Fieldbus Box modules.

- Thus, the coupler's input and output images can be observed by monitoring.
- Process values can be specified in the output image for commissioning of the output modules.

All possibilities in the *online mode* can be used in parallel with the actual fieldbus mode of the terminal station. The fieldbus protocol always has the higher priority in this case.

5 Access from the user program

5.1 Terminal configuration

The terminal can be configured and parameterized via the internal register structure. Each terminal channel is mapped in the Bus Coupler. Mapping of the terminal data in the Bus Coupler memory may differ, depending on the Bus Coupler type and the set mapping configuration (e.g. Motorola/Intel format, word alignment etc.). In contrast to the analog input and output terminals, in the KL2502 the control byte and the status byte are **always** mapped, irrespective of the fieldbus system used.

BK2000 Lightbus coupler

With the BK2000 Lightbus coupler, the control/status byte is always mapped in addition to the data bytes (i.e. for all analog terminals). This is always located in the low byte at the offset address of the terminal channel.

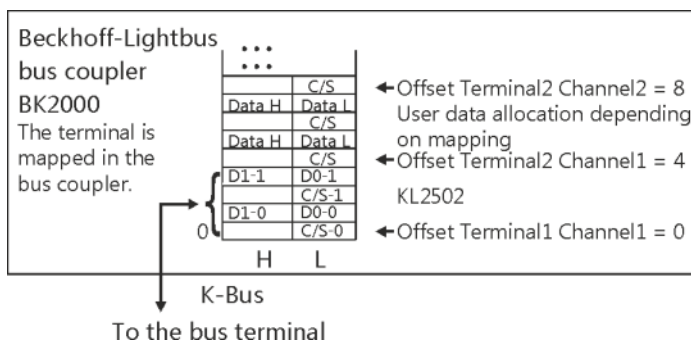

Fig. 13: Mapping in the Lightbus coupler – example for KL2502

Profibus coupler BK3000

With the BK3000 Profibus coupler, the KL2502 is represented by 6 bytes of input data and 6 bytes of output data (3 bytes per channel) as standard. Thus, 2 bytes of user data and 1 byte control/status data are mapped per channel.

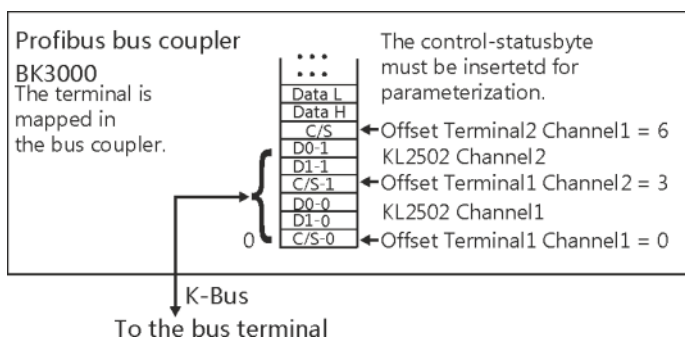

Fig. 14: Mapping in the Profibus coupler – example for KL2502

BK4000 Interbus Coupler

In delivery state, the BK4000 Interbus Coupler maps the terminals with 6 bytes of input data and 6 bytes of output data. Parameterization via the fieldbus is not possible. If the control and status byte is to be used, the KS2000 configuration software is required.

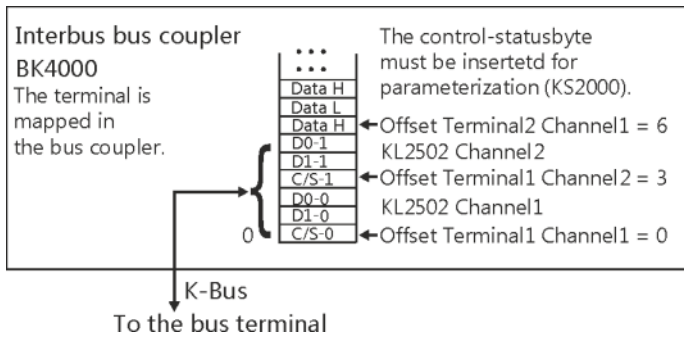

Fig. 15: Mapping in the Interbus coupler – example for KL2502

Other Bus Couplers and further information

Further information about the mapping configuration of Bus Couplers can be found in the Appendix of the respective Bus Coupler manual under *Master configuration*.

The chapter on Mapping in the Bus Coupler contains an overview of possible mapping configurations, depending on the configurable parameters.

Parameterization with KS2000

The KS2000 configuration software can be used for parameterizations via the serial interface of the Bus Coupler, independent of the fieldbus system.

5.2 Mapping in the Bus Coupler

As already described in the Terminal Configuration chapter, each Bus Terminal is mapped in the Bus Coupler. This mapping is usually done with the default setting in the Bus Coupler / Bus Terminal. The KS2000 configuration software or a master configuration software (e.g. ComProfibus or TwinCAT System Manager) can be used to change this default setting.

If the terminals are fully evaluated, they occupy memory space in the input and output process image.

The following tables provide information about how the terminals map themselves in the Bus Coupler, depending on the parameters set.

The KL2502 is mapped with 6 bytes of input and output data.

5.2.1 KL2502

Default mapping for: CANopen, CANCEL, DeviceNet, ControlNet, Modbus, RS232 and RS485 coupler

| Conditions | Word offset | High byte | Low byte |
|---|-------------|-----------|-----------|
| Complete evaluation: any Motorola format: no Word alignment: no | 0 | Ch1 D0 | Ch1 CB/SB |
| | 1 | Ch2 CB/SB | Ch1 D1 |
| | 2 | Ch2 D1 | Ch2 D0 |
| | 3 | - | - |

Default mapping for: Profibus and Interbus Coupler

| Conditions | Word offset | High byte | Low byte |
|--|-------------|-----------|-----------|
| Complete evaluation: any Motorola format: yes Word alignment: no | 0 | Ch1 D1 | Ch1 CB/SB |
| | 1 | Ch2 CB/SB | Ch1 D0 |
| | 2 | Ch2 D0 | Ch2 D1 |
| | 3 | - | - |

Default mapping for: Lightbus, EtherCAT & Ethernet coupler and Bus Terminal Controller (BCxxxx, BXxxxx)

| Conditions | Word offset | High byte | Low byte |
|--|-------------|-----------|-----------|
| Complete evaluation: any Motorola format: no Word alignment: yes | 0 | Res. | Ch1 CB/SB |
| | 1 | Ch1 D1 | Ch1 D0 |
| | 2 | Res. | Ch2 CB/SB |
| | 3 | Ch2 D1 | Ch2 D0 |

| Conditions | Word offset | High byte | Low byte |
|---|-------------|-----------|-----------|
| Complete evaluation: any Motorola format: yes Word alignment: yes | 0 | Res. | Ch1 CB/SB |
| | 1 | Ch1 D0 | Ch1 D1 |
| | 2 | Res. | Ch2 CB/SB |
| | 3 | Ch2 D0 | Ch2 D1 |

Key

| | |
|---------------------|--|
| Complete evaluation | The terminal is mapped with control and status byte. |
| Motorola format | Motorola or Intel format can be set. |
| Word alignment | The terminal is positioned on a word boundary in the Bus Coupler. |
| Ch n CB | Control byte for channel n (appears in the process image of the outputs). |
| Ch n SB | Status byte for channel n (appears in the process image of the inputs). |
| Ch n D0 | Channel n, data byte 0 (byte with the lowest value) |
| Ch n D1 | Channel n, data byte 1 (byte with the highest value) |
| "." | This byte is not used or occupied by the terminal. |
| Res. | Reserved: this byte is assigned to the process data memory, although it has no function. |

5.3 Register overview

These registers exist once for each channel

| Address | Designation | Default value | R/W | Storage medium |
|------------|------------------------------|---|-----|----------------|
| R0 | reserved | 0x0000 (0 _{dec}) | R | |
| R1 | reserved | 0x0000 (0 _{dec}) | R | |
| R2 [▶ 30] | Cycle duration | variable | R/W | RAM |
| R3 [▶ 30] | Base frequency | variable | R/W | RAM |
| R4 | reserved | 0x0000 (0 _{dec}) | R | |
| R5 [▶ 30] | PWM raw value | variable | R | RAM |
| R6 | Diagnostic register not used | 0x0000 (0 _{dec}) | R | |
| R7 | Command register - reserved | 0x0000 (0 _{dec}) | R/W | |
| R8 [▶ 30] | Terminal type | 0x09C6 (2502 _{dec}), 0x09D0 (2512 _{dec}) | R | ROM |
| R9 [▶ 30] | Software version number | 0x???? | R | ROM |
| R10 [▶ 30] | Multiplex shift register | 0x0218 (536 _{dec}), 0x0130 (304 _{dec}) | R | ROM |
| R11 [▶ 30] | Signal channels | 0x0218 (536 _{dec}) | R | ROM |
| R12 [▶ 30] | Minimum data length | 0x1818 (6468 _{dec}) | R | ROM |
| R13 [▶ 31] | Data structure | 0x0000 (0 _{dec}) | R | ROM |
| R14 | reserved | 0x0000 (0 _{dec}) | R | |
| R15 [▶ 31] | Alignment register | variable | R/W | RAM |
| R16 [▶ 31] | Hardware version number | 0x???? | R/W | SEEPROM |
| R17, R18 | reserved | 0x0000 (0 _{dec}) | R/W | SEEPROM |
| R19 [▶ 31] | Manufacturer scaling: Offset | 0x0000 (0 _{dec}) | R/W | SEEPROM |
| R20 [▶ 31] | Manufacturer scaling: Gain | 0x0100 (256 _{dec}) | R/W | SEEPROM |
| R21...R30 | reserved | 0x0000 (0 _{dec}) | R | SEEPROM |
| R31 [▶ 31] | Code word register | variable | R/W | RAM |
| R32 [▶ 32] | Feature register | 0x0004 (4 _{dec}) | R/W | SEEPROM |
| R33 [▶ 32] | User offset | 0x0000 (0 _{dec}) | R/W | SEEPROM |
| R34 [▶ 32] | User gain | 0x0100 (256 _{dec}) | R/W | SEEPROM |
| R35 [▶ 32] | Cycle duration PWM | 0x0FA0 (4000 _{dec}) | R/W | SEEPROM |
| R36 [▶ 32] | Duty cycle | 0x4000 (16384 _{dec}) | R/W | SEEPROM |
| R37 [▶ 32] | Pulse duration | 0x0005 (5 _{dec}) | R/W | SEEPROM |
| R38...R63 | Base frequency 2 (low word) | 0x86A0 (34464 _{dec}) | R/W | SEEPROM |

5.4 Register description

The registers can be read or written via the register communication. They are used for the parameterization of the terminal.

R0 to R7: Registers in the internal RAM of the terminal

The process variables can be used in addition to the actual process image. Their function is specific to the terminal.

- **R0, R1: no function**
- **R2 cycle duration**
In PWM mode, you can specify the cycle duration for ongoing operation. Following a power-on reset, the cycle duration is taken from [R35](#) [[▶](#) [32](#)] (cycle duration for PWM mode).
 - PWMH mode, Cnt-Cnt PWM mode:
 - 1 digit corresponds to 1 μ s
 - Example: 250 Hz => 4000 μ s = 0xFA0
 - 4 KHz => 250 μ s = 0xFA
 - PWML mode, Frq-Cnt PWM mode, Frq-Cnt pulse mode:
 - 1 digit corresponds to 8 μ s
 - Example: 2 Hz => 500 ms = 0xF424
 - 200 Hz => 5 ms = 0x271
- **R3 base frequency**
In PWM mode the base frequency can be specified here. [R/W]
1 digit corresponds to 1 Hz
- **R4: Reserved**
- **R5: PWM raw value**
The raw value of the processor PWM unit is stored in this register. This value can be used to calculate the maximum resolution at a specified frequency.
- **R6: Diagnostic register**
not used
- **R7: Command register**
High-Byte_Write = function parameter
Low-Byte_Write = function number
High-Byte_Read = function result
Low-Byte_Read = function number

R8 to R15: Registers in the internal ROM of the terminal

The type and system parameters are hard programmed by the manufacturer, and the user can read them but cannot change them.

- **R8: Terminal type**
The terminal type in register R8 is needed to identify the terminal.
- **R9: Software version (X.y)**
The software version can be read as a string of ASCII characters.
- **R10: Data length**
R10 contains the number of multiplexed shift registers and their length in bits.
The Bus Coupler sees this structure.
- **R11: Signal channels**
Related to R10, this contains the number of channels that are logically present. Thus for example a shift register that is physically present can perfectly well consist of several signal channels.
- **R12: Minimum data length**
The particular byte contains the minimum data length for a channel that is to be transferred. If the MSB is set, the control and status byte is not necessarily required for the terminal function and is not transferred to the control, if the Bus Coupler is configured accordingly.

- **R13: Data type register**

| Data type register | Meaning |
|--------------------|---|
| 0x00 | Terminal with no valid data type |
| 0x01 | Byte array |
| 0x02 | Structure 1 byte n bytes |
| 0x03 | Word array |
| 0x04 | Structure 1 byte n words |
| 0x05 | Double word array |
| 0x06 | Structure 1 byte n double words |
| 0x07 | Structure 1 byte 1 double word |
| 0x08 | Structure 1 byte 1 double word |
| 0x11 | Byte array with variable logical channel length |
| 0x12 | Structure 1 byte n bytes with variable logical channel length (e.g. 60xx) |
| 0x13 | Word array with variable logical channel length |
| 0x14 | Structure 1 byte n words with variable logical channel length |
| 0x15 | Double word array with variable logical channel length |
| 0x16 | Structure 1 byte n double words with variable logical channel length |

- **R14: reserved**
- **R15: Alignment bits (RAM)**
The alignment bits are used to place the analog terminal in the Bus Coupler on a byte boundary.

R16 to R30: Manufacturer parameter area (SEEROM)

The manufacturer parameters are specific for each type of terminal. They are programmed by the manufacturer, but can also be modified by the controller. The manufacturer parameters are stored in a serial EEPROM in the terminal, and are retained in the event of voltage drop-out.

These registers can only be altered after a code word has been set in R31 [▶ 31].

- **R16: Hardware version number**
Register R16 contains the hardware version of the terminal.
- **R19: Manufacturer scaling - offset (B_h)**
16 bit signed integer
Line equation: $Y = A_hX + B_h$
This register contains the offset of the manufacturer's linearization equation. The line equation is enabled via feature register R32 [▶ 32].
- **R20: Manufacturer scaling - gain (A_h)**
16 bit signed integer*2⁸
This register contains the scale factor of the manufacturer's linearization equation. The line equation is enabled via feature register R32 [▶ 32].
1 corresponds to register value 0x0100.

R31 to R47: User parameter area (SEEROM)

The user parameters are specific for each type of terminal. They can be modified by the programmer. The user parameters are stored in a serial EEPROM in the terminal, and are retained in the event of voltage drop-out. The user area is write-protected by a code word.



- **R31: Code word register in RAM**

The code word **0x1235** must be entered here so that parameters in the user area can be modified. If any other value is entered into this register, the write-protection is active. When write protection is not active, the code word is returned when the register is read. If the write protection is active, the register contains a zero value.

- **R32: Feature register**

[0x0004]

This register specifies the operation mode of the terminal. Thus, for instance, a user-specific scaling can be enabled for the analog I/Os.

| Feature bit no. | | Description of the operation mode | |
|-----------------|-----|--|------------------------|
| Bit 0 | 1 | User scaling active [0] | |
| Bit1 | 1 | Manufacturer scaling active [0] | |
| Bit 2 | 0 | [0] watchdog timer active; the PWM signal is set to 0 % duty cycle if the terminal does not receive any data for 100 ms. | |
| Bits 3-12 | 0 | Reserved, do not modify! | |
| Bit 13...15 | | [000] Operation mode | Range of values |
| | 000 | PWMH mode [000] | 250 Hz - 20 kHz |
| | 001 | PWML mode | 2 Hz - 250 Hz |
| | 011 | Frq-Cnt PWM mode | 2 Hz - 2 kHz |
| | 101 | Frq-Cnt pulse mode | 2 Hz - 2 kHz |
| | 111 | Cnt-Cnt PWM mode | 250 Hz - 8 kHz |

- **R33: User scaling - offset (B_w)**

16 bit signed integer

Line equation: $Y = A_w X + B_w$

This register contains the offset of the user linearization equation. The line equation is enabled via feature register [R32](#) [[▶ 32](#)].

- **R34: User scaling - gain (A_w)**

16 bit signed integer*2⁻⁸

This register contains the scale factor of the user linearization equation. The line equation is enabled via feature register [R32](#) [[▶ 32](#)].

- **R35: Cycle duration for PWM mode**

[0x0FA0]

After a processor restart, the cycle duration of [R35](#) [[▶ 32](#)] is entered in R2.

During operation it can be modified via [R2](#) [[▶ 30](#)] (cycle duration) or [R3](#) [[▶ 30](#)] (base frequency).

The input takes place as described under R2.

- **R36: Duty cycle**

[0x4000]

The ratio of duty cycle to cycle duration in Frq-Cnt PWM mode and Cnt-Cnt PWM mode is determined by this register.

0x2000 corresponds to 25 % duty cycle

0x4000 corresponds to 50 % duty cycle.

- **R37: Pulse duration for Frq-Cnt pulse mode**

[0x0005]

This register is used to enter the pulse duration in Frq-Cnt pulse mode.

1 digit corresponds to 8 μs.

5.5 Control and status byte

The control and status byte is transmitted from the controller to the terminal. It can be used

- in register mode [▶ 33] ($REG = 1_{bin}$) or
- in process data exchange ($REG = 0_{bin}$).

5.5.1 Register communication

Register access via process data exchange

- **Bit 7=1: Register mode**
If bit 7 of the control byte is set, the first two bytes of the user data are not used for process data exchange but written into the register set of the terminal or read from it.
- **Bit 6=0: read, bit 6=1: write**
Bit 6 of the control bytes is used to specify whether a register should be read or written.
 - **Bit 6=0:** a register is read without changing it. The value can be found in the input process image.
 - **Bit 6=1:** the user data are written to a register. The process is complete once the status byte in the input process image has returned an acknowledgment (see example).
- **Bit 0 to 5: Address**
The address of the register to be addressed is entered in bits 0 to 5 of the control byte.

Control byte in register mode (REG=1)

MSB

| | | | | | | | |
|-------|-----|----|----|----|----|----|----|
| REG=1 | W/R | A5 | A4 | A3 | A2 | A1 | A0 |
|-------|-----|----|----|----|----|----|----|

$REG = 0_{bin}$: Process data exchange
 $REG = 1_{bin}$: Access to register structure

$W/R = 0_{bin}$: Read register
 $W/R = 1_{bin}$: Write register

A5..A0 = register address
 Addresses A5...A0 can be used to address a total of 64 registers.

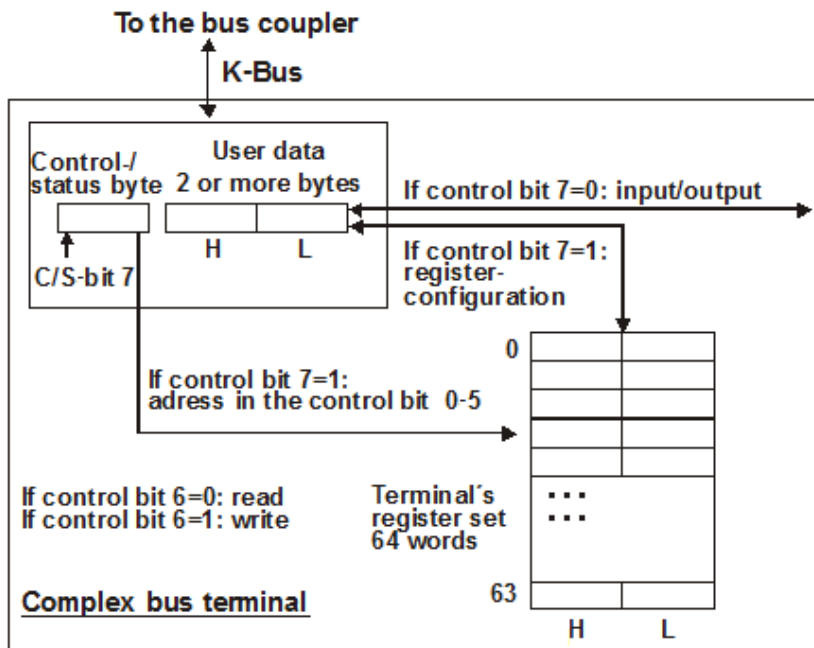

Fig. 16: Register mode control byte

The control or status byte occupies the lowest address of a logical channel. The corresponding register values are located in the following 2 data bytes. (The BK2000 is an exception: here, an unused data byte is inserted after the control or status byte, and the register value is therefore placed on a word boundary).

Example 1:**Reading of register 8 in the BK2000 with a KL3022 and the end terminal:**

If the following bytes are transferred from the controller to the terminal,

| Byte | Byte 3 | Byte 2 | Byte 1 | Byte 0 |
|--------------|--------------------|---------------------|----------|--------------|
| Name | Data out, low byte | Data out, high byte | Not used | Control byte |
| Value | 0xXX | 0xXX | 0xXX | 0x88 |

the terminal returns the following type identifier (0x0BBA corresponds to unsigned integer 3022).

| Byte | Byte 3 | Byte 2 | Byte 1 | Byte 0 |
|--------------|-------------------|--------------------|----------|-------------|
| Name | Data in, low byte | Data in, high byte | Not used | Status byte |
| Value | 0xCE | 0x0B | 0x00 | 0x88 |

Example 2:**Write register 31 in the BK2000 with an intelligent and the end terminal:**

If the following bytes (code word [▶ 31]) are transferred from the controller to the terminal,

| Byte | Byte 3 | Byte 2 | Byte 1 | Byte 0 |
|--------------|--------------------|---------------------|----------|--------------|
| Name | Data out, low byte | Data out, high byte | Not used | Control byte |
| Value | 0x35 | 0x12 | 0xXX | 0xDF |

The code word [▶ 31] is set, and the terminal returns the register address with bit 7 for register access as acknowledgment.

| Byte | Byte 3 | Byte 2 | Byte 1 | Byte 0 |
|--------------|-------------------|--------------------|----------|-------------|
| Name | Data in, low byte | Data in, high byte | Not used | Status byte |
| Value | 0x00 | 0x00 | 0x00 | 0x9F |

5.6 Examples of Register Communication

The numbering of the bytes in the examples corresponds to the display without word alignment.

5.6.1 Example 1: reading the firmware version from Register 9

Output Data

| Byte 0: Control byte | Byte 1: DataOUT1, high byte | Byte 2: DataOUT1, low byte |
|----------------------------------|-----------------------------|----------------------------|
| 0x89 (1000 1001 _{bin}) | 0xXX | 0xXX |

Explanation:

- Bit 0.7 set means: Register communication switched on.
- Bit 0.6 not set means: reading the register.
- Bits 0.5 to 0.0 specify the register number 9 with 00 1001_{bin}.
- The output data word (byte 1 and byte 2) has no meaning during read access. To change a register, write the required value into the output word.

Input Data (answer of the bus terminal)

| Byte 0: Status byte | Byte 1: DataIN1, high byte | Byte 2: DataIN1, low byte |
|---------------------|----------------------------|---------------------------|
| 0x89 | 0x33 | 0x41 |

Explanation:

- The terminal returns the value of the control byte as a receipt in the status byte.
- The terminal returns the firmware version 0x3341 in the input data word (byte 1 and byte 2). This is to be interpreted as an ASCII code:
 - ASCII code 0x33 represents the digit 3
 - ASCII code 0x41 represents the letter A
 The firmware version is thus 3A.

5.6.2 Example 2: Writing to a user register

Code word

In normal mode all user registers are read-only with the exception of Register 31. In order to deactivate this write protection you must write the code word (0x1235) into Register 31. If a value other than 0x1235 is written into Register 31, write protection is reactivated. Please note that changes to a register only become effective after restarting the terminal (power-off/power-on).

I. Write the code word (0x1235) into Register 31.

Output Data

| Byte 0: Control byte | Byte 1: DataOUT1, high byte | Byte 2: DataOUT1, low byte |
|----------------------------------|-----------------------------|----------------------------|
| 0xDF (1101 1111 _{bin}) | 0x12 | 0x35 |

Explanation:

- Bit 0.7 set means: Register communication switched on.
- Bit 0.6 set means: writing to the register.
- Bits 0.5 to 0.0 specify the register number 31 with 01 1111_{bin}.
- The output data word (byte 1 and byte 2) contains the code word (0x1235) for deactivating write protection.

Input Data (answer of the bus terminal)

| Byte 0: Status byte | Byte 1: DataIN1, high byte | Byte 2: DataIN1, low byte |
|----------------------------------|----------------------------|---------------------------|
| 0x9F (1001 1111 _{bin}) | 0xFF | 0xFF |

Explanation:

- The terminal returns a value as a receipt in the status byte that differs only in bit 0.6 from the value of the control byte.
- The input data word (byte 1 and byte 2) is of no importance after the write access. Any values still displayed are invalid!

II. Read Register 31 (check the set code word)

Output Data

| Byte 0: Control byte | Byte 1: DataOUT1, high byte | Byte 2: DataOUT1, low byte |
|----------------------------------|-----------------------------|----------------------------|
| 0x9F (1001 1111 _{bin}) | 0xFF | 0xFF |

Explanation:

- Bit 0.7 set means: Register communication switched on.

- Bit 0.6 not set means: reading the register.
- Bits 0.5 to 0.0 specify the register number 31 with $01\ 1111_{\text{bin}}$.
- The output data word (byte 1 and byte 2) has no meaning during read access.

Input Data (answer of the bus terminal)

| Byte 0: Status byte | Byte 1: DataIN1, high byte | Byte 2: DataIN1, low byte |
|------------------------------------|----------------------------|---------------------------|
| 0x9F ($1001\ 1111_{\text{bin}}$) | 0x12 | 0x35 |

Explanation:

- The terminal returns the value of the control byte as a receipt in the status byte.
- The terminal returns the current value of the code word register in the input data word (byte 1 and byte 2).

III. Write to Register 32 (change contents of the feature register)

Output data

| Byte 0: Control byte | Byte 1: DataIN1, high byte | Byte 2: DataIN1, low byte |
|------------------------------------|----------------------------|---------------------------|
| 0xE0 ($1110\ 0000_{\text{bin}}$) | 0x00 | 0x02 |

Explanation:

- Bit 0.7 set means: Register communication switched on.
- Bit 0.6 set means: writing to the register.
- Bits 0.5 to 0.0 indicate register number 32 with $10\ 0000_{\text{bin}}$.
- The output data word (byte 1 and byte 2) contains the new value for the feature register.

⚠ CAUTION

Observe the register description!

The value of 0x0002 given here is just an example!

The bits of the feature register change the properties of the terminal and have a different meaning, depending on the type of terminal. Refer to the description of the feature register of your terminal (chapter *Register description*) regarding the meaning of the individual bits before changing the values.

Input data (response from the Bus Terminal)

| Byte 0: Status byte | Byte 1: DataIN1, high byte | Byte 2: DataIN1, low byte |
|------------------------------------|----------------------------|---------------------------|
| 0xA0 ($1010\ 0000_{\text{bin}}$) | 0xFF | 0xFF |

Explanation:

- The terminal returns a value as a receipt in the status byte that differs only in bit 0.6 from the value of the control byte.
- The input data word (byte 1 and byte 2) is of no importance after the write access. Any values still displayed are invalid!

IV. Read Register 32 (check changed feature register)

Output Data

| Byte 0: Control byte | Byte 1: DataOUT1, high byte | Byte 2: DataOUT1, low byte |
|------------------------------------|-----------------------------|----------------------------|
| 0xA0 ($1010\ 0000_{\text{bin}}$) | 0xFF | 0xFF |

Explanation:

- Bit 0.7 set means: Register communication switched on.
- Bit 0.6 not set means: reading the register.

- Bits 0.5 to 0.0 indicate register number 32 with 10 0000_{bin}.
- The output data word (byte 1 and byte 2) has no meaning during read access.

Input Data (answer of the bus terminal)

| Byte 0: Status byte | Byte 1: DataIN1, high byte | Byte 2: DataIN1, low byte |
|----------------------------------|----------------------------|---------------------------|
| 0xA0 (1010 0000 _{bin}) | 0x00 | 0x02 |

Explanation:

- The terminal returns the value of the control byte as a receipt in the status byte.
- The terminal returns the current value of the feature register in the input data word (byte 1 and byte 2).

V. Write Register 31 (reset code word)

Output Data

| Byte 0: Control byte | Byte 1: DataOUT1, high byte | Byte 2: DataOUT1, low byte |
|----------------------------------|-----------------------------|----------------------------|
| 0xDF (1101 1111 _{bin}) | 0x00 | 0x00 |

Explanation:

- Bit 0.7 set means: Register communication switched on.
- Bit 0.6 set means: writing to the register.
- Bits 0.5 to 0.0 specify the register number 31 with 01 1111_{bin}.
- The output data word (byte 1 and byte 2) contains 0x0000 for reactivating write protection.

Input Data (answer of the bus terminal)

| Byte 0: Status byte | Byte 1: DataIN1, high byte | Byte 2: DataIN1, low byte |
|----------------------------------|----------------------------|---------------------------|
| 0x9F (1001 1111 _{bin}) | 0xFF | 0xFF |

Explanation:

- The terminal returns a value as a receipt in the status byte that differs only in bit 0.6 from the value of the control byte.
- The input data word (byte 1 and byte 2) is of no importance after the write access. Any values still displayed are invalid!

6 Appendix

6.1 Support and Service

Beckhoff and their partners around the world offer comprehensive support and service, making available fast and competent assistance with all questions related to Beckhoff products and system solutions.

Beckhoff's branch offices and representatives

Please contact your Beckhoff branch office or representative for [local support and service](#) on Beckhoff products!

The addresses of Beckhoff's branch offices and representatives round the world can be found on her internet pages:

<http://www.beckhoff.com>

You will also find further [documentation](#) for Beckhoff components there.

Beckhoff Headquarters

Beckhoff Automation GmbH & Co. KG

Huelshorstweg 20
33415 Verl
Germany

Phone: +49(0)5246/963-0
Fax: +49(0)5246/963-198
e-mail: info@beckhoff.com

Beckhoff Support

Support offers you comprehensive technical assistance, helping you not only with the application of individual Beckhoff products, but also with other, wide-ranging services:

- support
- design, programming and commissioning of complex automation systems
- and extensive training program for Beckhoff system components

Hotline: +49(0)5246/963-157
Fax: +49(0)5246/963-9157
e-mail: support@beckhoff.com

Beckhoff Service

The Beckhoff Service Center supports you in all matters of after-sales service:

- on-site service
- repair service
- spare parts service
- hotline service

Hotline: +49(0)5246/963-460
Fax: +49(0)5246/963-479
e-mail: service@beckhoff.com

List of illustrations

| | | |
|---------|--|----|
| Fig. 1 | KL2502 | 8 |
| Fig. 2 | KL2512 | 9 |
| Fig. 3 | Spring contacts of the Beckhoff I/O components..... | 13 |
| Fig. 4 | Attaching on mounting rail | 14 |
| Fig. 5 | Disassembling of terminal..... | 15 |
| Fig. 6 | Power contact on left side..... | 16 |
| Fig. 7 | Standard wiring..... | 17 |
| Fig. 8 | Pluggable wiring | 17 |
| Fig. 9 | High Density Terminals..... | 18 |
| Fig. 10 | Connecting a cable on a terminal point | 19 |
| Fig. 11 | KL2502, KL2512 - Connection and LEDs..... | 21 |
| Fig. 12 | KS2000 configuration software..... | 24 |
| Fig. 13 | Mapping in the Lightbus coupler – example for KL2502..... | 26 |
| Fig. 14 | Mapping in the Profibus coupler – example for KL2502 | 26 |
| Fig. 15 | Mapping in the Interbus coupler – example for KL2502 | 27 |
| Fig. 16 | Register mode control byte | 33 |