

Documentation

KL2535, KL2545

Pulse width current terminals

Version: 2.0.0
Date: 2016-02-29

BECKHOFF

Table of contents

1 Foreword	4
1.1 Notes on the documentation	4
1.2 Safety instructions	5
1.3 Documentation issue status	6
2 Product overview	7
2.1 KL2535 - Introduction	7
2.2 KL2535 - Technical Data	8
2.3 KL2535 - LED displays	9
2.4 KL2545 - Introduction	10
2.5 KL2545 - Technical Data	11
2.6 KL2545 - LED displays	12
2.7 Pulse width modulation	13
2.8 Functions	14
3 Mounting and wiring	18
3.1 Installation on mounting rails	18
3.2 Prescribed installation position	20
3.3 Connection system	21
3.4 KL2535 - Connection	25
3.5 KL2545 - Connection	26
4 Configuration software KS2000	28
4.1 KS2000 - Introduction	28
4.2 Parameterization with KS2000	29
4.3 Settings	31
4.4 Register	34
4.5 Process data	35
5 Access from the user program	37
5.1 Process image	37
5.2 Control and status bytes	38
5.3 Register overview	40
5.4 Register description	41
5.5 Examples of Register Communication	45
5.5.1 Example 1: reading the firmware version from Register 9 of a terminal	45
5.5.2 Example 2: Writing to a user register	45
6 Appendix	48
6.1 Support and Service	48

1 Foreword

1.1 Notes on the documentation

This description is only intended for the use of trained specialists in control and automation engineering who are familiar with the applicable national standards.

It is essential that the following notes and explanations are followed when installing and commissioning these components.

The responsible staff must ensure that the application or use of the products described satisfy all the requirements for safety, including all the relevant laws, regulations, guidelines and standards.

Disclaimer

The documentation has been prepared with care. The products described are, however, constantly under development. For that reason the documentation is not in every case checked for consistency with performance data, standards or other characteristics. In the event that it contains technical or editorial errors, we retain the right to make alterations at any time and without warning. No claims for the modification of products that have already been supplied may be made on the basis of the data, diagrams and descriptions in this documentation.

Trademarks

Beckhoff®, TwinCAT®, EtherCAT®, Safety over EtherCAT®, TwinSAFE®, XFC® and XTS® are registered trademarks of and licensed by Beckhoff Automation GmbH & Co. KG.

Other designations used in this publication may be trademarks whose use by third parties for their own purposes could violate the rights of the owners.

Patent Pending

The EtherCAT Technology is covered, including but not limited to the following patent applications and patents: EP1590927, EP1789857, DE102004044764, DE102007017835 with corresponding applications or registrations in various other countries.

The TwinCAT Technology is covered, including but not limited to the following patent applications and patents: EP0851348, US6167425 with corresponding applications or registrations in various other countries.

EtherCAT®

EtherCAT® is registered trademark and patented technology, licensed by Beckhoff Automation GmbH, Germany

Copyright

© Beckhoff Automation GmbH & Co. KG, Germany.

The reproduction, distribution and utilization of this document as well as the communication of its contents to others without express authorization are prohibited.

Offenders will be held liable for the payment of damages. All rights reserved in the event of the grant of a patent, utility model or design.

1.2 Safety instructions

Safety regulations

Please note the following safety instructions and explanations!
 Product-specific safety instructions can be found on following pages or in the areas mounting, wiring, commissioning etc.

Exclusion of liability





All the components are supplied in particular hardware and software configurations appropriate for the application. Modifications to hardware or software configurations other than those described in the documentation are not permitted, and nullify the liability of Beckhoff Automation GmbH & Co. KG.

Personnel qualification

This description is only intended for trained specialists in control, automation and drive engineering who are familiar with the applicable national standards.

Description of symbols

In this documentation the following symbols are used with an accompanying safety instruction or note. The safety instructions must be read carefully and followed without fail!

 DANGER	<p>Serious risk of injury! Failure to follow the safety instructions associated with this symbol directly endangers the life and health of persons.</p>
 WARNING	<p>Risk of injury! Failure to follow the safety instructions associated with this symbol endangers the life and health of persons.</p>
 CAUTION	<p>Personal injuries! Failure to follow the safety instructions associated with this symbol can lead to injuries to persons.</p>
 Attention	<p>Damage to the environment or devices Failure to follow the instructions associated with this symbol can lead to damage to the environment or equipment.</p>
 Note	<p>Tip or pointer This symbol indicates information that contributes to better understanding.</p>

1.3 Documentation issue status

Version	Comment
2.0.0	<ul style="list-style-type: none"> • Migration
1.5.0	<ul style="list-style-type: none"> • Technical data updated
1.4.0	<ul style="list-style-type: none"> • Product overview extended
1.3.0	<ul style="list-style-type: none"> • Mounting instructions updated
1.2.0	<ul style="list-style-type: none"> • Mounting instructions extended • Technical data updated • Register overview updated
1.1.0	<ul style="list-style-type: none"> • Connection description for the KL2535 corrected • Basic function principles corrected • Hardware version of the KL2535 corrected
1.0	First publication
0.1	Internal proof copy

Firmware and hardware versions

Documentation version	KL2535		KL2545	
	Firmware	Hardware	Firmware	Hardware
1.5.0	1B	04	2B	08
1.4.0	1B	01	1B	05
1.3.0	1B	01	1B	05
1.2.0	1B	01	1B	05
1.1.0	1B	00	1A	02
1.0	1B	00	1A	02
0.1	1B	00	1A	02

The firmware and hardware versions (delivery state) can be taken from the serial number printed on the side of the terminal.

Syntax of the serial number

Structure of the serial number: WW YY FF HH

WW - week of production (calendar week)

YY - year of production

FF - firmware version

HH - hardware version

Example with ser. no.: 12 06 1A 02:

12 - week of production 12

06 - year of production 2006

1A - firmware version 1A

02 - hardware version 02

2 Product overview

2.1 KL2535 - Introduction

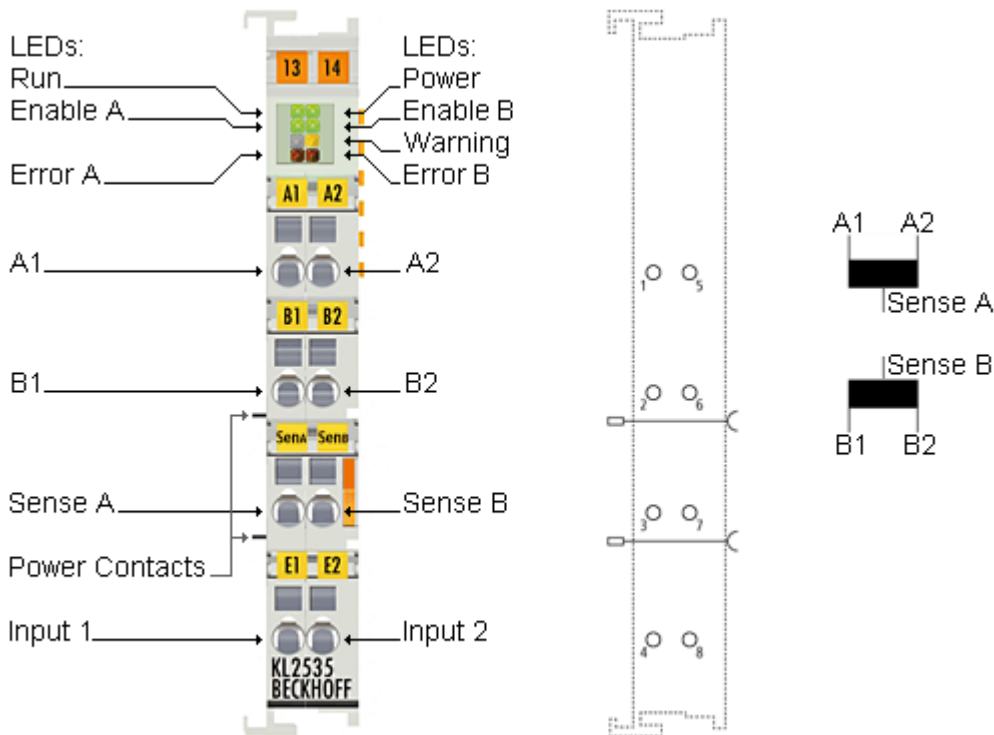

Fig. 1: KL2535

The KL2535 two-channel pulse width current terminal regulates an output current by means of pulse width control of the supply voltage. The current value (0 A to 1 A) is specified with 16-bit resolution by the automation device.

The output stage is protected against overload and short-circuit and is electrically isolated from the K-bus. Both channels indicate their state by LEDs, enabling fast on-the-spot diagnosis.

The Bus Terminal is available in the KL2535 version for [standard wiring \[► 22\]](#) and the KS2535 for [permanent wiring \[► 21\]](#).

2.2 KL2535 - Technical Data

Technical data	KL2535/KS2535
Number of output stages	2
Load type	ohmic/inductive > 1 mH
Supply for the output stage	24 V _{DC} via power contacts
Output current per channel	1 A (short-circuit-proof, common thermal overload warning for both output stages)
PWM clock frequency	36 kHz
Resolution	max. 12 bit
Number of digital inputs	2 digital inputs (24 V)
Nominal voltage of the inputs	24 V _{DC} (-15%/+20%)
Signal voltage "0"	-3 V... 2 V
Signal voltage "1"	15 V... 30 V
Input filter	0.2 ms
Input current	typically 5 mA
Electrical isolation	500 V (K-bus/mains voltage)
Supply voltage for internal E-bus circuit	via the K-bus
Current consumption from K-bus	typically: 60 mA
Current consumption from the power contacts	typically: 10 mA
Bit width in the input process image	2 x 16 bit data, 2 x 8 bit status
Bit width in the output process image	2 x 16 bit data, 2 x 8 bit control
Configuration	via the Bus Coupler or the controller
Weight	approx. 55 g
Permissible ambient temperature range during operation	0°C ... + 55°C
Permissible ambient temperature range during storage	-25°C ... + 85°C
Permissible relative humidity	95%, no condensation
Dimensions (W x H x D)	approx. 15 mm x 100 mm x 70 mm (width aligned: 12 mm)
Mounting ▶ 18	on 35 mm mounting rail conforms to EN 60715
Vibration/shock resistance	conforms to EN 60068-2-6 / EN 60068-2-27
EMC immunity/emission	conforms to EN 61000-6-2 / EN 61000-6-4
Protection class	IP20
Correct installation position	see section Installation position ▶ 20
Approval	CE

2.3 KL2535 - LED displays

LED indicators

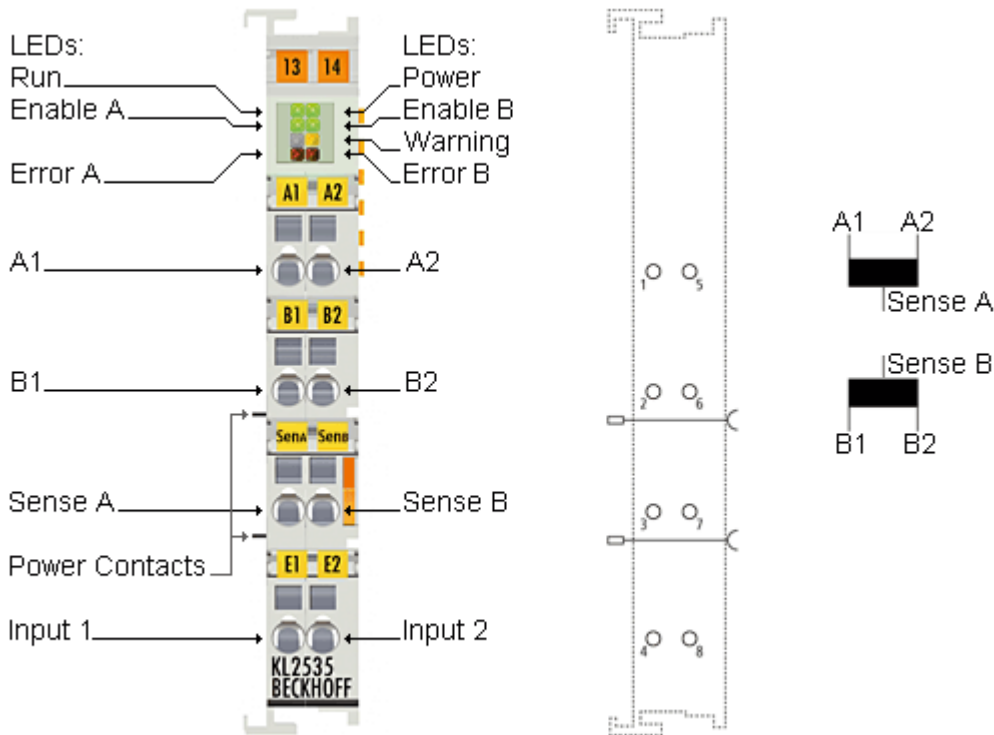

Fig. 2: KL2535 - LEDs

LED	Display	
Run (green)	reserved	Data transmission on the K-bus is active
Enable A (green)	off	Channel 1 is either not enabled or not ready to operate.
	on	Channel 1 is enabled and is ready to operate.
-	reserved	
Error A (red)	on	There is an error at channel 1
Power (green)	off	The power supply voltage is absent (less than 7 V).
	on	The power supply voltage is present (more than 8 V).
Enable B (green)	off	Channel 2 is either not enabled or not ready to operate.
	on	Channel 2 is enabled and is ready to operate.
Warning (yellow)	on	The internal temperature has risen to more than 80°C, or the power supply voltage has dropped.
Error B (red)	on	There is an error at channel 2

2.4 KL2545 - Introduction

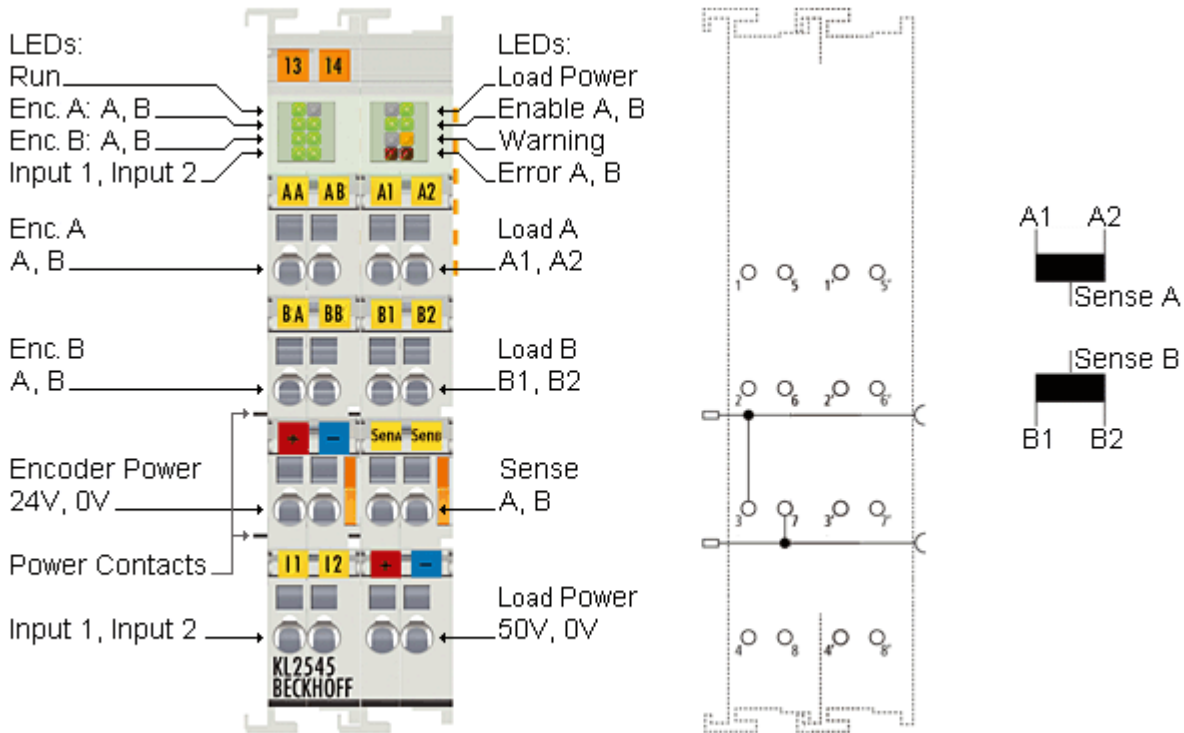

Fig. 3: KL2545

The KL2545 two-channel pulse width current terminal regulates an output current by means of pulse width control of the supply voltage. The current value (0 A to 3.5 A) is specified with 16-bit resolution by the automation device.

The output stage is protected against overload and short-circuit and is electrically isolated from the K-bus. Both channels indicate their state by LEDs, enabling fast on-the-spot diagnosis. An incremental encoder can be connected to each channel for the implementation of the position feedback directly in the terminal.

The Bus Terminal is available in the KL2545 version for [standard wiring \[► 22\]](#) and the KS2545 for [permanent wiring \[► 21\]](#).

2.5 KL2545 - Technical Data

Technical data	KL2545/KS2545
Number of output stages	2
Load type	ohmic/inductive > 1 mH
Supply for the output stage	8 V _{DC} to 50 V _{DC} , via terminal locations
Output current per channel	3.5 A (short-circuit-proof, common thermal overload warning for both output stages)
PWM clock frequency	36 kHz
Resolution	max. 12 bit
Number of digital inputs	2 (for end positions)
Rated voltage of the digital inputs	24 V _{DC} (-15%/+20%)
Signal voltage "0" at digital inputs	-3 V ... 2 V
Signal voltage "1" at digital inputs	15 V ... 30 V
Input filter	0.2 ms
Input current	typically 5 mA
Number of encoder inputs	4 (for an encoder system)
Encoder voltage "0"	-3 V ... 1.5 V
Encoder voltage "1"	2.5 V ... 24 V
Electrical isolation	500 V (K-bus/mains voltage)
Supply voltage for internal E-bus circuit	via the K-bus
Current consumption from K-bus	typically: 100 mA
Current consumption from the power contacts	typically: 20 mA
Power loss	typically: 4 W
Bit width in the input process image	2 x 16 bit data, 2 x 8 bit status
Bit width in the output process image	2 x 16 bit data, 2 x 8 bit control
Configuration	via the Bus Coupler or the controller
Weight	approx. 100 g
Permissible ambient temperature range during operation	0°C ... + 55°C
Permissible ambient temperature range during storage	-25°C ... + 85°C
Permissible relative humidity	95%, no condensation
Dimensions (W x H x D)	approx. 27 mm x 100 mm x 70 mm (width aligned: 24 mm)
Mounting ▶ 18	on 35 mm mounting rail conforms to EN 60715
Vibration/shock resistance	conforms to EN 60068-2-6 / EN 60068-2-27
EMC immunity/emission	conforms to EN 61000-6-2 / EN 61000-6-4
Protection class	IP20
Correct installation position	see section Installation position ▶ 20
Approval	CE

2.6 KL2545 - LED displays

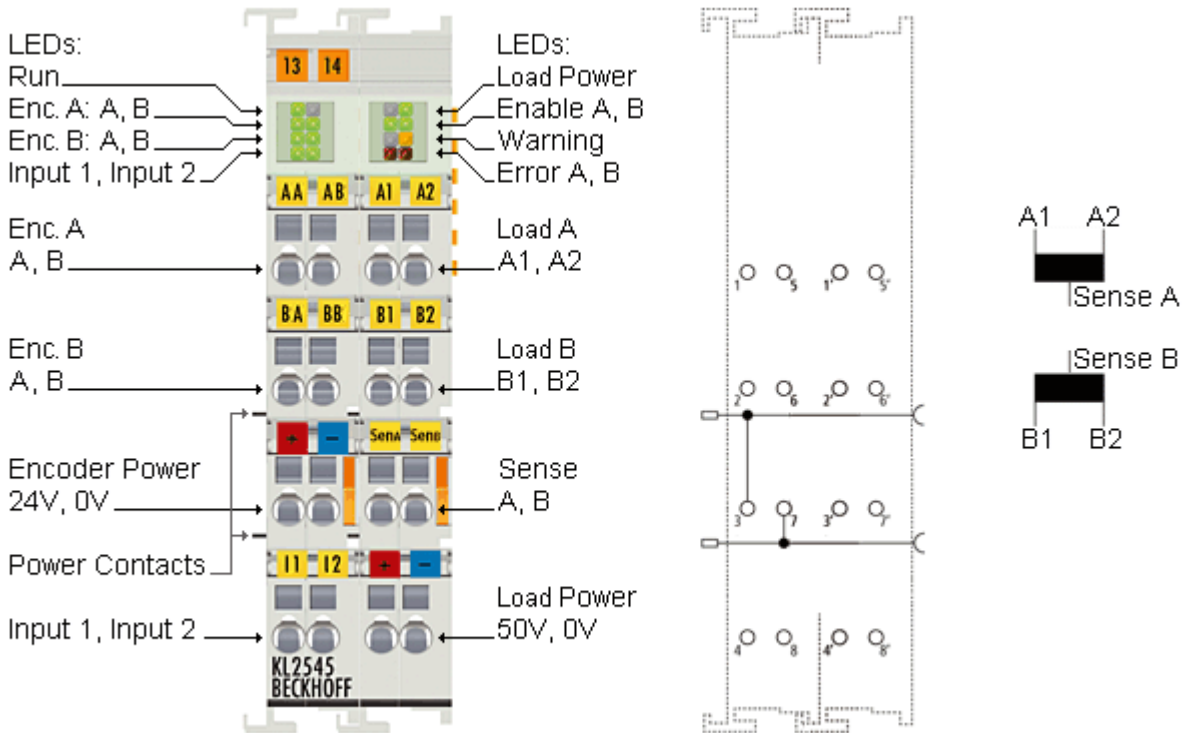

Fig. 4: KL2545 - LEDs

Left LED prism

LED	Display	
Run (green)	on	Data transmission on the K-bus is active
Enc. A: A (green)	on	There is a signal at input A for encoder A.
Enc. B: A (green)	on	There is a signal at input A for encoder B.
Input 1 (green)	on	There is a signal at input 1.
-	reserved	
Enc. A: B (green)	on	There is a signal at input B for encoder A.
Enc. B: B (green)	on	There is a signal at input B for encoder B.
Input 2 (green)	on	There is a signal at input 2.

Right LED prism

LED	Display	
-	reserved	
Enable A (green)	off	Channel 1 is either not enabled or not ready to operate.
	on	Channel 1 is enabled and is ready to operate.
-	reserved	
Error A (red)	on	There is an error at channel 1
Load Power (green)	off	The power supply voltage for the load is absent (less than 7 V).
	on	The power supply voltage for the load is present (more than 8 V).
Enable B (green)	off	Channel 2 is either not enabled or not ready to operate.
	on	Channel 2 is enabled and is ready to operate.
Warning (yellow)	on	The internal temperature has risen to more than 80°C, or the power supply voltage has dropped.
Error B (red)	on	There is an error at channel 2

2.7 Pulse width modulation

The KL2535 and KL2545 pulse-width current terminals include an integrated PWM output stage (up to 175 W) in a very compact design.

By means of the PWM output stage the pulse width modulation (PWM) of the supply voltage is used to regulate the output current of a connected ohmic/inductive load. The full supply voltage, pulsating with a certain frequency, is thereby fed to the output. A load current only develops at the inductance at the high level. The load current is not changed by changing the voltage level, but by the duration of the switch-off (pulse width) in relation to the period duration. This results in a duty factor corresponding to the pulse width divided by the period duration of between 0 and 100% and is proportional to the load current.

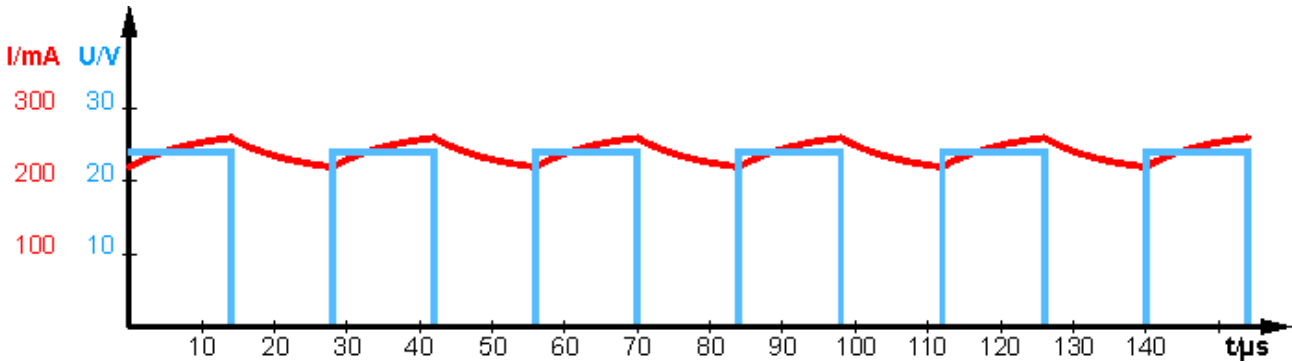

Fig. 5: Operation at load with adequate inductance

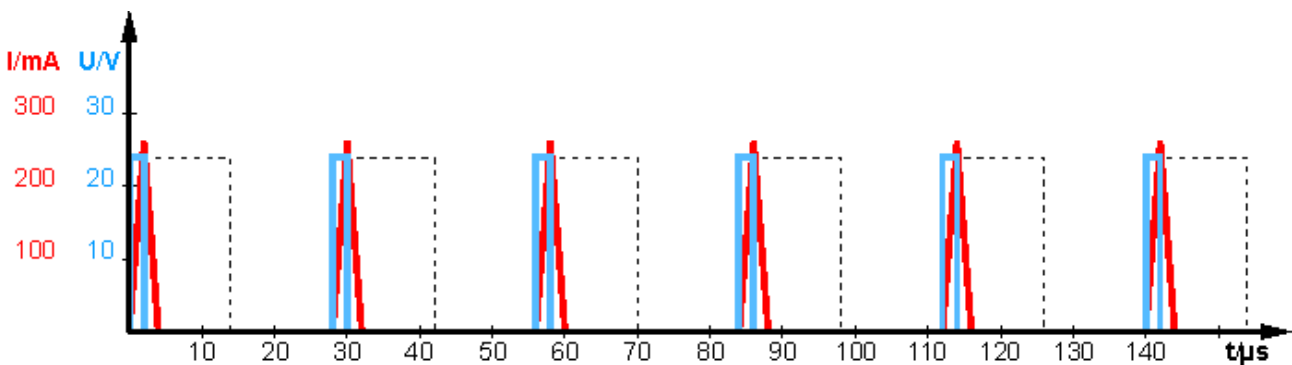

Fig. 6: Operation at load inadequate inductance (near ohmic)

The figure "Operation at load with inadequate inductance" illustrates operation with an inadequate inductance. Continuous current flow is not reached. The current has "gaps". This mode of operation is not permitted.



Note

Pulse width current terminals require inductive loads

The load inductance should have a minimum inductance of 1 mH. Operation of the pulse width current terminals at loads with an inductance of less than 1 mH is not recommended, since the intermittent current flow prevents reference between the set value and the arithmetic mean of the current.

2.8 Functions

The KL2535 and KL2545 pulse-width current terminals include an integrated PWM output stage (up to 175 W) in a very compact design.

General functions

Enable/Readiness for operation

The enable bit [CB1.5 \[▶ 38\]](#) in the control byte must be set in order to activate the output stage. If the terminal is not subject to an error at this time, it acknowledges the command by setting the ready bit, [SB1.4 \[▶ 38\]](#), in the status byte

Setting/deleting the position (KL2545 only)

The current position value of the encoder can be set or deleted by the user. Register [R1 \[▶ 41\]](#) is the reference for this. A rising edge at bit [CB1.1 \[▶ 38\]](#) sets the current position, and the acknowledgement is provided through status bit [SB1.1 \[▶ 38\]](#).

Latch functions

The internal encoder offers the option of registering a latch event. A latch event can be generated via the digital input signals.

The terminal response to the latch events is activated as follows:

- Setting the control bit [CB1.2 \[▶ 38\]](#) activates the rising edge at the digital input (highest priority)
- Setting the control bit [CB1.3 \[▶ 38\]](#) activates the falling edge at the digital input (second-highest priority)

Once the user has enabled the function, during the next latch event, the terminal saves the current position value and indicates this by setting status bit [SB1.2 \[▶ 38\]](#). Reading out the latch value must be started by setting [CB1.4 \[▶ 38\]](#); this will map the latch value into the DataIN process data (the terminal indicates this through status bit [SB1.3 \[▶ 38\]](#)).



Note

Enable for latch values

The enable that was set previously must be retained while reading out the latch value. The latch values are lost if the enable is removed!

Digital inputs

The digital inputs are mapped into the status byte in bit [SB1.0 \[▶ 38\]](#).

Error indication

The terminal offers the user a variety of diagnostic options. These messages are divided into hardware warnings and hardware errors.

Hardware warnings

When one of the following warning occurs, bit [SB1.5 \[▶ 38\]](#) (Warning) is set in the status byte.

- OverTemperature [R0.8 \[▶ 41\]](#)
(If the temperature inside the terminal reaches 80°C, bit [SB1.5 \[▶ 38\]](#) (Warning) is set. The bit is automatically reset if the temperature falls below 60°C.)
- LowVoltage [R0.9 \[▶ 41\]](#)

Hardware error

If one of the following errors occurs, the load is de-energized and bit [SB1.6 \[▶ 38\]](#) (Error) is set in the Status byte.

- UnderVoltage [R0.11 \[▶ 41\]](#)
- OverCurrent, [R0.12 \[▶ 41\]](#)
- Open load / broken wire (OpenLoad, [R0.13 \[▶ 41\]](#))
- Failure of the 24 V control supply (NoControlPower, [R0.14 \[▶ 41\]](#))
(The terminal is automatically reinitialized when the control voltage returns)

If an error occurs, it first has to be rectified and subsequently acknowledged and thus cancelled by setting bit [CB1.6 \[▶ 38\]](#) in the control byte.

Dithering

Feature bit [R32.5 \[▶ 43\]](#) and control bit [CB1.0 \[▶ 38\]](#) must be set to activate the dither.

The purpose of this function is to eliminate magnetization effects. Dithering involves modulating a rectangular signal on top of the actual output value. The configuration required for this depends a lot on the particular application. It must be determined with the aid of the characteristic data of whatever actuator is connected.

The following parameters can be set:

Name	Register	Value range	Description
Frequency - f	R37 [▶ 44]	10 Hz to 500 Hz	The frequency of the rectangular signal; the resolution of the setting is 1 Hz.
Amplitude - i	R38 [▶ 44]	0% to 100%	The amplitude of the rectangular signal; the resolution is 1% (with reference to the output current that has been set in register R36 [▶ 43])
Switch-off ramp - t	R39 [▶ 44]	0 ms to 32767 ms	When switched on, the dither signal jumps immediately to the amplitude set in R38. When switched off, the signal is attenuated linearly over the time configured here; the resolution is 1 ms.

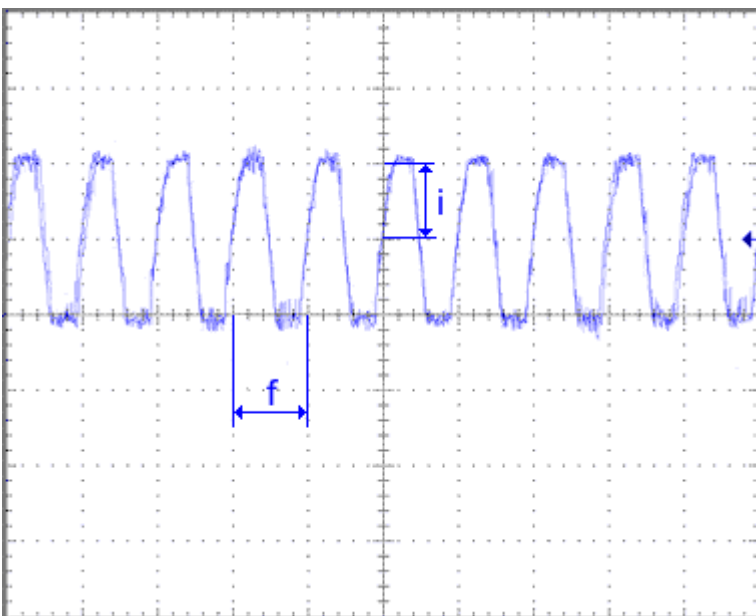

Fig. 7: Frequency - f / Amplitude - i

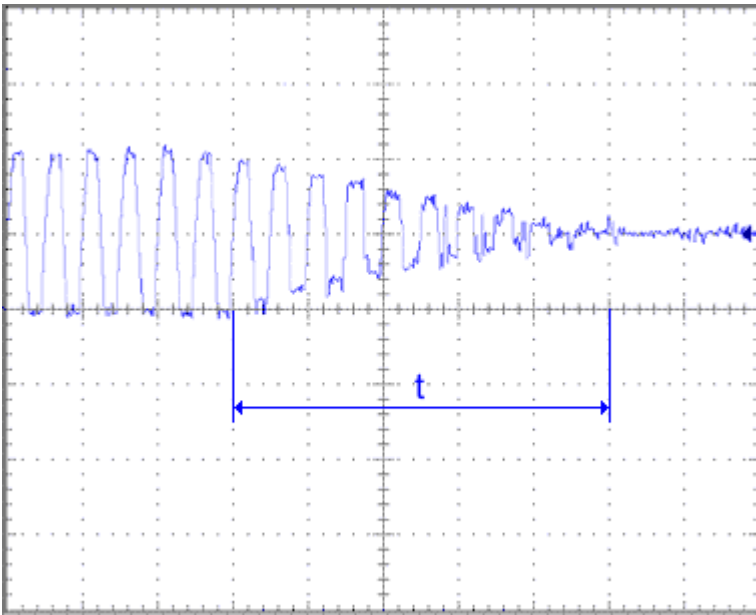

Fig. 8: Switch-off ramp - t

Valve curve

Feature bit [R32.4](#) [[▶ 43](#)] must be set in order to activate the valve curve.

The following parameters can be set:

Name	Register	Value range	Description
Overlap threshold value - x_1	R40 [▶ 44]	0 to 1000	The overlap range ends at this process data value; the resolution is 0.1% (as a fraction of 32767)
Overlap output value - y_1	R41 [▶ 44]	0 to 1000	The maximum output current in the overlap region; the resolution is 0.1% (with reference to the output current that has been set in register R36 [▶ 43])
Bend compensation -threshold value- x_2	R42 [▶ 44]	0 to 1000	The bend compensation range ends at this process data value; the resolution is 0.1% (as a fraction of 32767)
Bend compensation - output value - y_2	R43 [▶ 44]	0 to 1000	The maximum output current in the bend compensation region; the resolution is 0.1% (with reference to the output current that has been set in register R36 [▶ 43])
Area compensation - threshold value - x_3	R44 [▶ 44]	0 to 1000	The area compensation region ends at this process data value; the resolution is 0.1% (as a fraction of 32767)

The characteristic curve is divided into four regions:

- I Overlapping
- II Bend compensation
- III, III' Area compensation
- IV End region

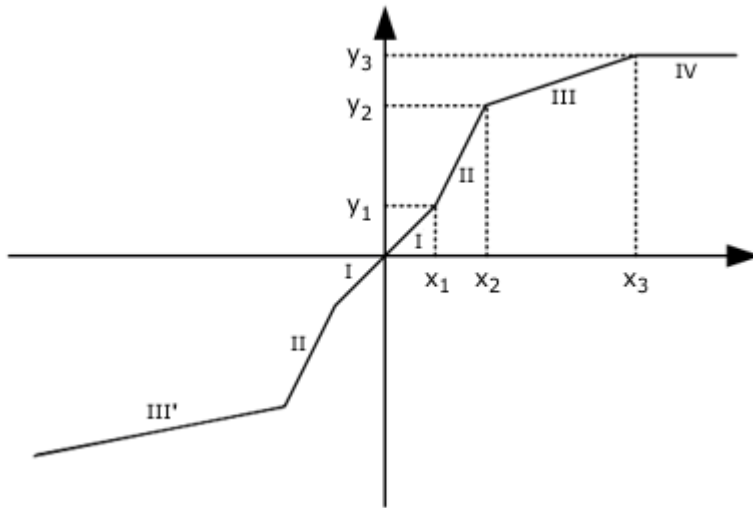

Fig. 9: Valve curve

Process data ramps

Feature bit R32.6 [▶ 43] must be set in order to activate the process data ramps.

This function offers the facility for automatically changing the output current from the current process data value to the new one up or down along a linear ramp. The values of registers R45 and R46 here are related to the entire process data range, i.e. from 0 to 32767.

The following parameters can be set:

Name	Register	Value range	Description
Rising ramp - t_1	R45 [▶ 44]	0 to 32767 ms	The time, t_1 , required for the process data value to rise from 0 to 32767 (resolution: 1 ms).
Falling ramp - t_2	R46 [▶ 45]	0 to 32767 ms	The time, t_2 , required for the process data value to fall from 32767 to 0 (resolution: 1 ms).

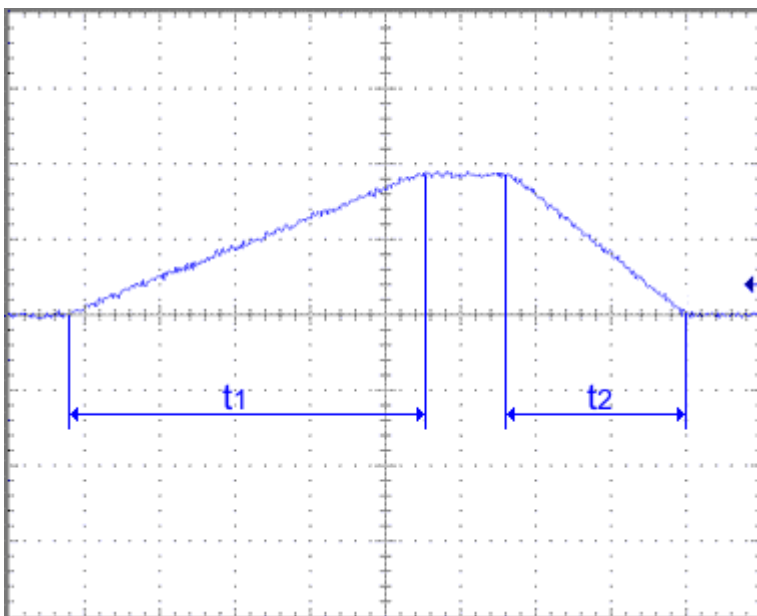

Fig. 10: Process data ramps

3 Mounting and wiring

3.1 Installation on mounting rails



WARNING

Risk of electric shock and damage of device!

Bring the bus terminal system into a safe, powered down state before starting installation, disassembly or wiring of the Bus Terminals!

Assembly

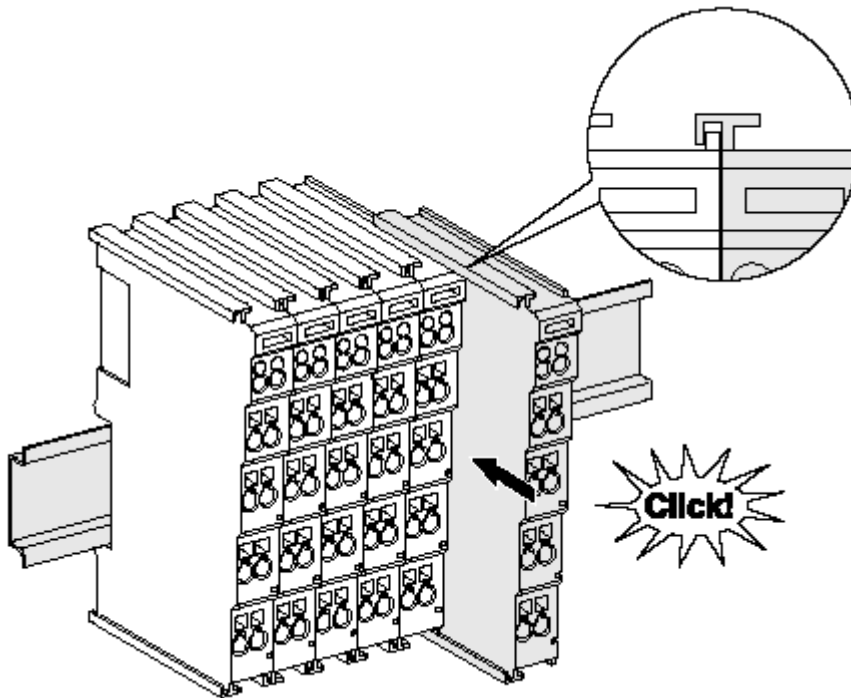

Fig. 11: Attaching on mounting rail

The Bus Coupler and Bus Terminals are attached to commercially available 35 mm mounting rails (DIN rails according to EN 60715) by applying slight pressure:

1. First attach the Fieldbus Coupler to the mounting rail.
2. The Bus Terminals are now attached on the right-hand side of the Fieldbus Coupler. Join the components with tongue and groove and push the terminals against the mounting rail, until the lock clicks onto the mounting rail.

If the Terminals are clipped onto the mounting rail first and then pushed together without tongue and groove, the connection will not be operational! When correctly assembled, no significant gap should be visible between the housings.



Note

Fixing of mounting rails

The locking mechanism of the terminals and couplers extends to the profile of the mounting rail. At the installation, the locking mechanism of the components must not come into conflict with the fixing bolts of the mounting rail. To mount the mounting rails with a height of 7.5 mm under the terminals and couplers, you should use flat mounting connections (e.g. countersunk screws or blind rivets).

Disassembly

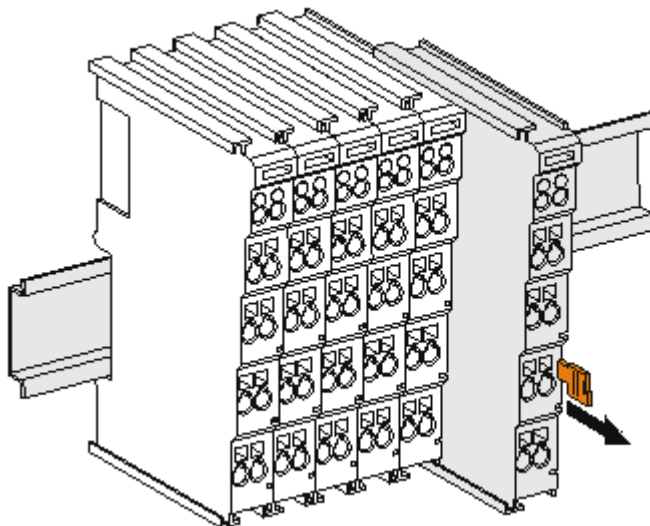

Fig. 12: Disassembling of terminal

Each terminal is secured by a lock on the mounting rail, which must be released for disassembly:

1. Pull the terminal by its orange-colored lugs approximately 1 cm away from the mounting rail. In doing so for this terminal the mounting rail lock is released automatically and you can pull the terminal out of the bus terminal block easily without excessive force.
2. Grasp the released terminal with thumb and index finger simultaneous at the upper and lower grooved housing surfaces and pull the terminal out of the bus terminal block.

Connections within a bus terminal block

The electric connections between the Bus Coupler and the Bus Terminals are automatically realized by joining the components:

- The six spring contacts of the K-Bus/E-Bus deal with the transfer of the data and the supply of the Bus Terminal electronics.
- The power contacts deal with the supply for the field electronics and thus represent a supply rail within the bus terminal block. The power contacts are supplied via terminals on the Bus Coupler (up to 24 V) or for higher voltages via power feed terminals.



Note

Power Contacts

During the design of a bus terminal block, the pin assignment of the individual Bus Terminals must be taken account of, since some types (e.g. analog Bus Terminals or digital 4-channel Bus Terminals) do not or not fully loop through the power contacts. Power Feed Terminals (KL91xx, KL92xx or EL91xx, EL92xx) interrupt the power contacts and thus represent the start of a new supply rail.

PE power contact

The power contact labeled PE can be used as a protective earth. For safety reasons this contact mates first when plugging together, and can ground short-circuit currents of up to 125 A.

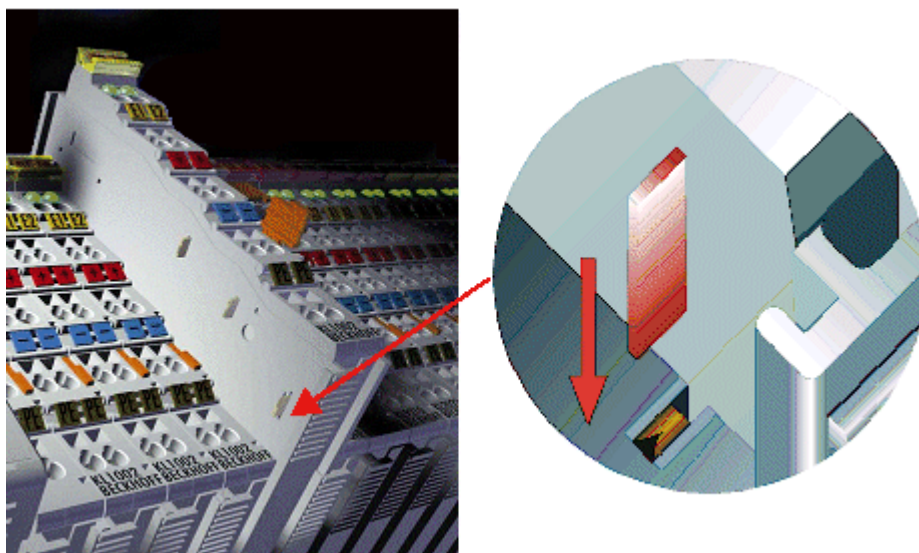

Fig. 13: Power contact on left side

	<p>Possible damage of the device</p>
<p>Attention</p>	<p>Note that, for reasons of electromagnetic compatibility, the PE contacts are capacitatively coupled to the mounting rail. This may lead to incorrect results during insulation testing or to damage on the terminal (e.g. disruptive discharge to the PE line during insulation testing of a consumer with a nominal voltage of 230 V). For insulation testing, disconnect the PE supply line at the Bus Coupler or the Power Feed Terminal! In order to decouple further feed points for testing, these Power Feed Terminals can be released and pulled at least 10 mm from the group of terminals.</p>

	<p>Risk of electric shock!</p>
<p>WARNING</p>	<p>The PE power contact must not be used for other potentials!</p>

3.2 Prescribed installation position

	<p>Constraints regarding installation position and operating temperature range</p>
<p>Attention</p>	<p>When installing the terminals ensure that an adequate spacing is maintained between other components above and below the terminal in order to guarantee adequate ventilation!</p>

Prescribed installation position

The prescribed installation position requires the mounting rail to be installed horizontally and the connection surfaces of the EL/KL terminals to face forward (see Fig. *Recommended distances for standard installation position*).

The terminals are ventilated from below, which enables optimum cooling of the electronics through convection. "From below" is relative to the acceleration of gravity.

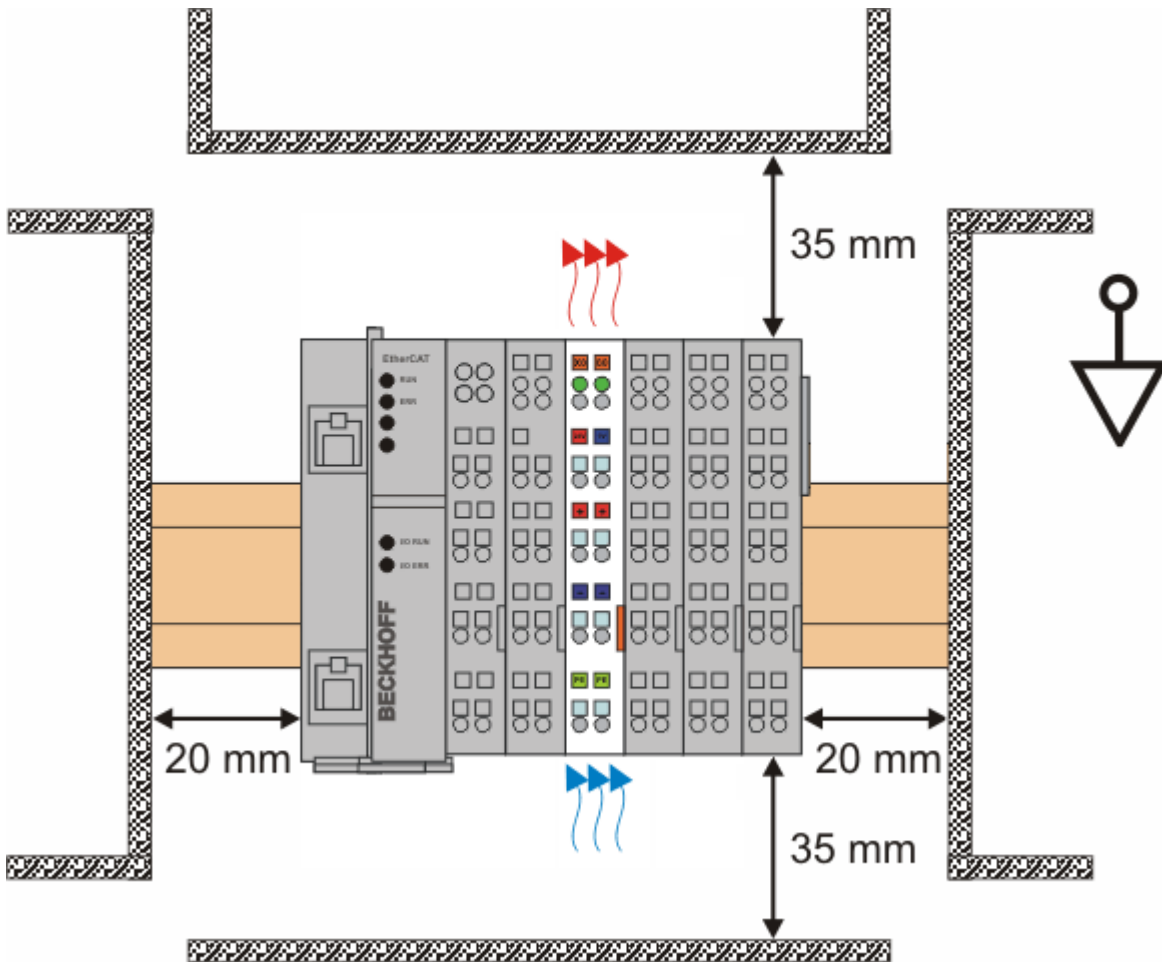



Fig. 14: Recommended distances for standard installation position

Compliance with the distances shown in Fig. Recommended distances for standard installation position is strongly recommended.

3.3 Connection system

 WARNING	<p>Risk of electric shock and damage of device!</p> <p>Bring the bus terminal system into a safe, powered down state before starting installation, disassembly or wiring of the Bus Terminals!</p>
---	---

Overview

The Bus Terminal system offers different connection options for optimum adaptation to the respective application:

- The terminals of KLxxxx and ELxxxx series with standard wiring include electronics and connection level in a single enclosure.
- The terminals of KSxxxx and ESxxxx series feature a pluggable connection level and enable steady wiring while replacing.
- The High Density Terminals (HD Terminals) include electronics and connection level in a single enclosure and have advanced packaging density.

Standard wiring



Fig. 15: Standard wiring

The terminals of KLxxxx and ELxxxx series have been tried and tested for years. They feature integrated screwless spring force technology for fast and simple assembly.

Pluggable wiring

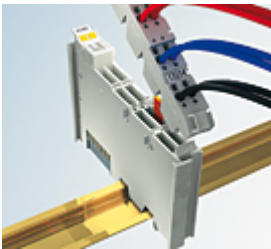

Fig. 16: Pluggable wiring

The terminals of KSxxxx and ESxxxx series feature a pluggable connection level. The assembly and wiring procedure for the KS series is the same as for the KLxxxx and ELxxxx series. The KS/ES series terminals enable the complete wiring to be removed as a plug connector from the top of the housing for servicing. The lower section can be removed from the terminal block by pulling the unlocking tab. Insert the new component and plug in the connector with the wiring. This reduces the installation time and eliminates the risk of wires being mixed up.

The familiar dimensions of the terminal only had to be changed slightly. The new connector adds about 3 mm. The maximum height of the terminal remains unchanged.

A tab for strain relief of the cable simplifies assembly in many applications and prevents tangling of individual connection wires when the connector is removed.

Conductor cross sections between 0.08 mm² and 2.5 mm² can continue to be used with the proven spring force technology.

The overview and nomenclature of the product names for KSxxxx and ESxxxx series has been retained as known from KLxxxx and ELxxxx series.

High Density Terminals (HD Terminals)



Fig. 17: High Density Terminals

The Bus Terminals from these series with 16 connection points are distinguished by a particularly compact design, as the packaging density is twice as large as that of the standard 12 mm Bus Terminals. Massive conductors and conductors with a wire end sleeve can be inserted directly into the spring loaded terminal point without tools.

 Note	<p>Wiring HD Terminals</p> <p>The High Density (HD) Terminals of the KLx8xx and ELx8xx series doesn't support steady wiring.</p>
--	---

Ultrasonically "bonded" (ultrasonically welded) conductors

 Note	<p>Ultrasonically "bonded" conductors</p> <p>It is also possible to connect the Standard and High Density Terminals with ultrasonically "bonded" (ultrasonically welded) conductors. In this case, please note the tables concerning the <u>wire-size width</u> [▶ 23] below!</p>
--	--

Wiring

Terminals for standard wiring ELxxxx / KLxxxx and terminals for steady wiring ESxxxx / KSxxxx

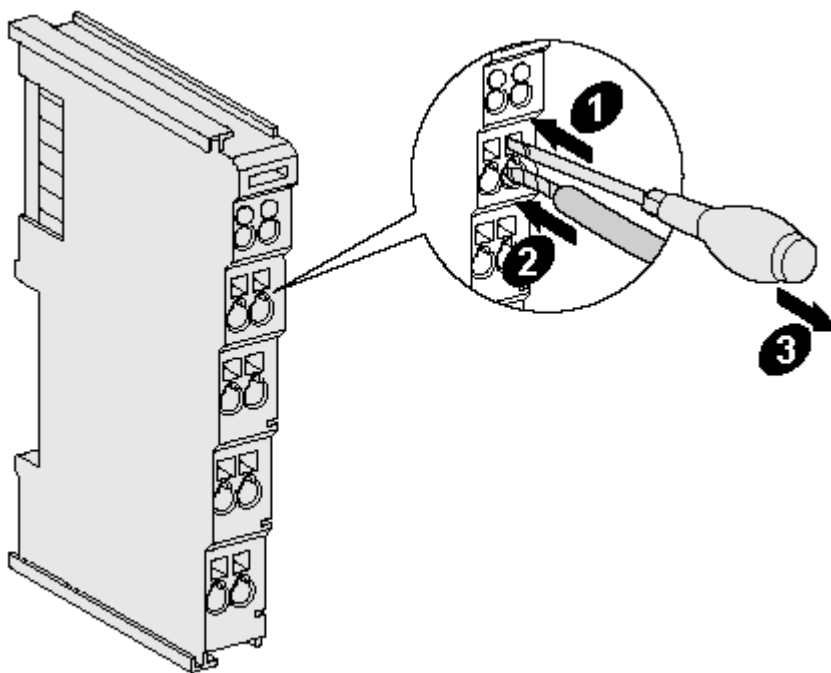

Fig. 18: Mounting a cable on a terminal connection

Up to eight connections enable the connection of solid or finely stranded cables to the Bus Terminals. The terminals are implemented in spring force technology. Connect the cables as follows:

1. Open a spring-loaded terminal by slightly pushing with a screwdriver or a rod into the square opening above the terminal.
2. The wire can now be inserted into the round terminal opening without any force.
3. The terminal closes automatically when the pressure is released, holding the wire securely and permanently.

Terminal housing	ELxxxx, KLxxxx	ESxxxx, KSxxxx
Wire size width	0.08 ... 2,5 mm ²	0.08 ... 2.5 mm ²
Wire stripping length	8 ... 9 mm	9 ... 10 mm

High Density Terminals ELx8xx, KLx8xx (HD)

The conductors of the HD Terminals are connected without tools for single-wire conductors using the direct plug-in technique, i.e. after stripping the wire is simply plugged into the contact point. The cables are released, as usual, using the contact release with the aid of a screwdriver. See the following table for the suitable wire size width.

Terminal housing	High Density Housing
Wire size width (conductors with a wire end sleeve)	0.14... 0.75 mm ²
Wire size width (single core wires)	0.08 ... 1.5 mm ²
Wire size width (fine-wire conductors)	0.25 ... 1.5 mm ²
Wire size width (ultrasonically "bonded" conductors)	only 1.5 mm ² (see notice [► 23]!)
Wire stripping length	8 ... 9 mm

Shielding



Note

Shielding

Analog sensors and actors should always be connected with shielded, twisted paired wires.

3.4 KL2535 - Connection



WARNING

Risk of injury through electric shock and damage to the device!

Bring the Bus Terminals system into a safe, de-energized state before starting mounting, disassembly or wiring of the Bus Terminals.

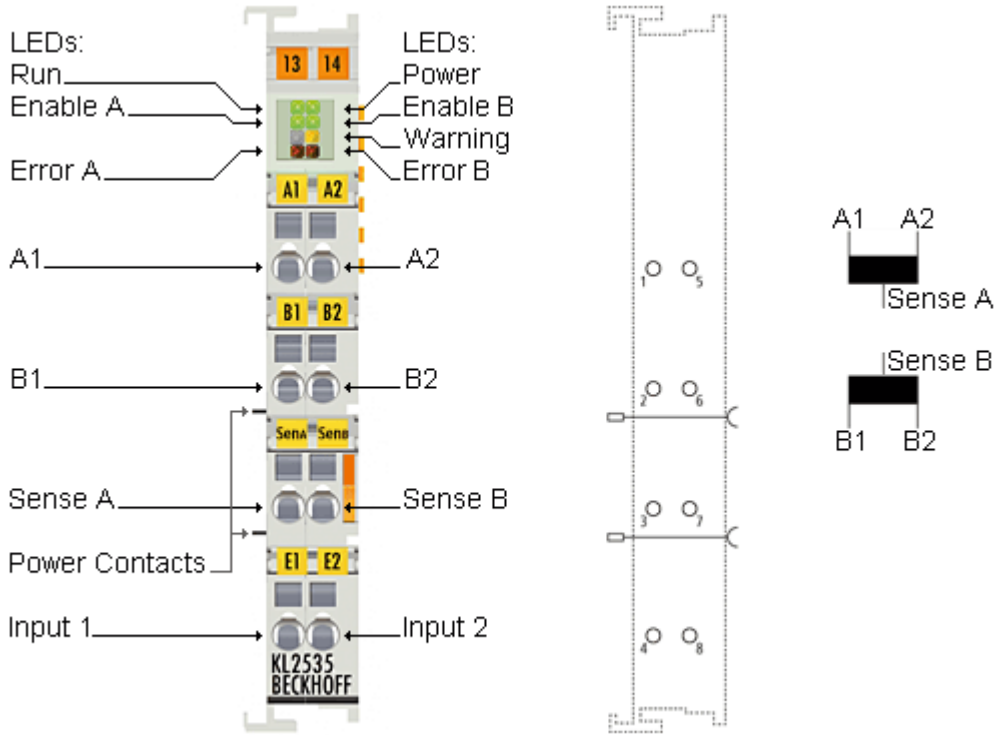



Fig. 19: KL2535 Connection

Terminal point	No.	Connection
A1	1	Load A, connection A1
B1	2	Load B, connection B1
Sense A	3	Load A, sense
Input 1	4	Digital input 1 (24 V _{DC}).
A2	5	Load A, connection A2
B2	6	Load B, connection B2
Sense B	7	Load B, sense
Input 2	8	Digital input 2 (24 V _{DC}).

3.5 KL2545 - Connection



WARNING

Risk of injury through electric shock and damage to the device!

Bring the Bus Terminals system into a safe, de-energized state before starting mounting, disassembly or wiring of the Bus Terminals.

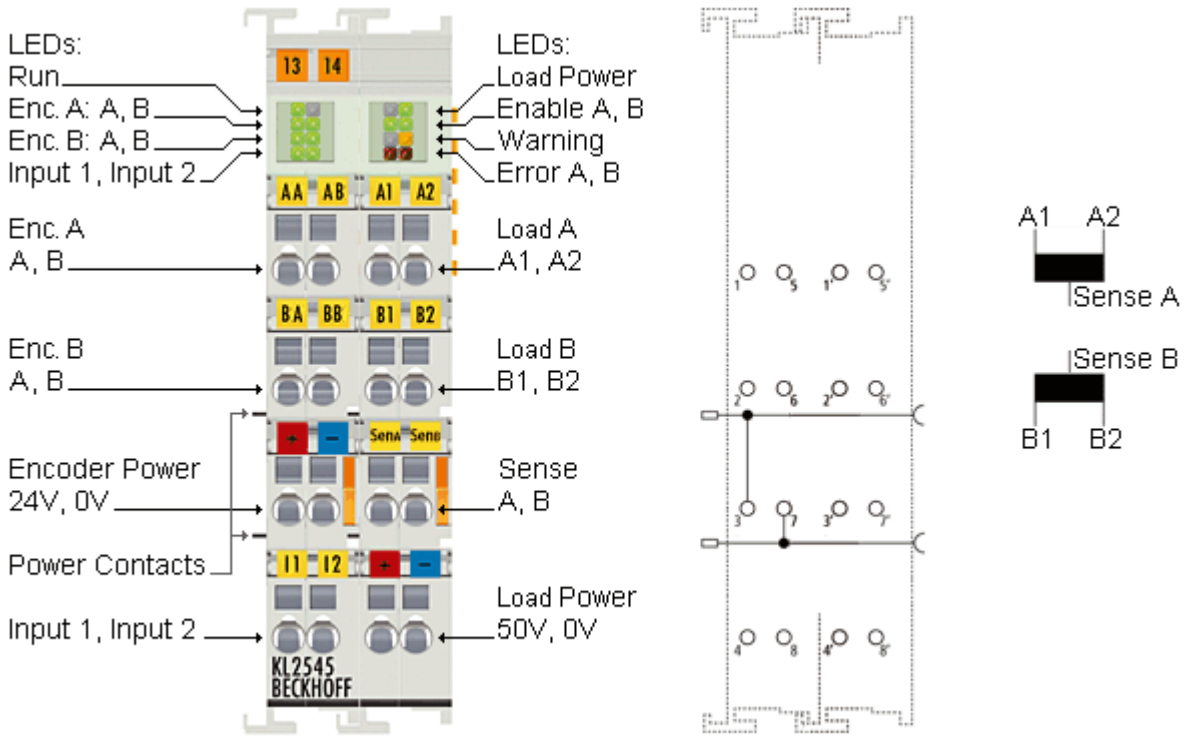

Fig. 20: KL2545 Connection

Left-hand section of the housing

Terminal point	No.	Connection for
Encoder A, A	1	Encoder A, connection A
Encoder B, A	2	Encoder B, connection A
Encoder Power +24 V	3	Encoder supply (from positive power contact)
Input 1	4	Digital input 1 (24 V _{DC}). The current counter value is saved as a reference mark in the latch register if bit CW.1 is set in the control word and a rising edge occurs at digital input 1.
Encoder A, B	5	Encoder A, connection B
Encoder B, B	6	Encoder B, connection B
Encoder Power 0 V	7	Encoder supply (from negative power contact)
Input 2	8	Digital input 2 (24 V _{DC}). The current counter value is saved as a reference mark in the latch register if bit CW.2 is set in the control word and a rising edge occurs at digital input 2.

Right-hand section of the housing

Terminal point (right)	No.	Connection for
Load A, A1	1'	Load A, connection A1
Load B, B1	2'	Load B, connection B1
Sense A	3'	Load A, sense
Load Power 50 V	4'	Power supply for supplying the load (maximum +50 V _{DC})
Load A, A2	5'	Load A, connection A2
Load B, B2	6'	Load B, connection B2
Sense B	7'	Load B, sense
Load Power 0 V	8'	Power supply for supplying the load (0 V _{DC})

Power contacts

The voltage Up of the power contacts (+24 V_{DC}) supplies the following consumers:

- Incremental encoder (terminal points 3 and 7)
- Digital inputs (terminal points 4 and 8)
- Output stage driver of the pulse width current terminal

 Note	<p>Order of switch-on of the supply voltages</p> <p>The voltage Up must already be present at the power contacts when the K-bus voltage is switched on so that the internal circuits (output stage drivers) can be initialized. If this is not possible due to the application (supply is switched, for example, via emergency stop circuit), the terminal performs a software reset after the system starts up. If the voltage Up at the power contacts fails, this is indicated by bit SW.14. The return of the voltage is automatically detected and an initialization is performed.</p>
--	--

 WARNING	<p>Valves are not reset if the K-bus voltage fails!</p> <p>If the K-bus voltage fails (5 V, supplied from the supply voltage Us of the Bus Coupler), the output drivers are not reset! This means that the valves are then not driven back to the initial position!</p>
---	--

4 Configuration software KS2000

4.1 KS2000 - Introduction

The KS2000 configuration software permits configuration, commissioning and parameterization of bus couplers, of the affiliated bus terminals and of Fieldbus Box Modules. The connection between bus coupler / Fieldbus Box Module and the PC is established by means of the serial configuration cable or the fieldbus.



Fig. 21: KS2000 configuration software

Configuration

You can configure the Fieldbus stations with the Configuration Software KS2000 offline. That means, setting up a terminal station with all settings on the couplers and terminals resp. the Fieldbus Box Modules can be prepared before the commissioning phase. Later on, this configuration can be transferred to the terminal station in the commissioning phase by means of a download. For documentation purposes, you are provided with the breakdown of the terminal station, a parts list of modules used and a list of the parameters you have modified. After an upload, existing fieldbus stations are at your disposal for further editing.

Parameterization

KS2000 offers simple access to the parameters of a fieldbus station: specific high-level dialogs are available for all bus couplers, all intelligent bus terminals and Fieldbus Box modules with the aid of which settings can be modified easily. Alternatively, you have full access to all internal registers of the bus couplers and intelligent terminals. Refer to the register description for the meanings of the registers.

Commissioning

The KS2000 software facilitates commissioning of machine components or their fieldbus stations: Configured settings can be transferred to the fieldbus modules by means of a download. After a *login* to the terminal station, it is possible to define settings in couplers, terminals and Fieldbus Box modules directly *online*. The same high-level dialogs and register access are available for this purpose as in the configuration phase.

The KS2000 offers access to the process images of the bus couplers and Fieldbus Box modules.

- Thus, the coupler's input and output images can be observed by monitoring.
- Process values can be specified in the output image for commissioning of the output modules.

All possibilities in the *online mode* can be used in parallel with the actual fieldbus mode of the terminal station. The fieldbus protocol always has the higher priority in this case.

4.2 Parameterization with KS2000

Connect the configuration interface of your fieldbus coupler with the serial interface of your PC via the configuration cable and start the *KS2000* configuration software.



Click on the *Login* button. The configuration software will now load the information for the connected fieldbus station.

In the example shown, this is

- Bus Coupler for Ethernet BK9000.
- a KL1xx2 digital input terminal.
- a KL2535 or KL2545 two-channel pulse width current terminal.
- a KL9010 bus end terminal.

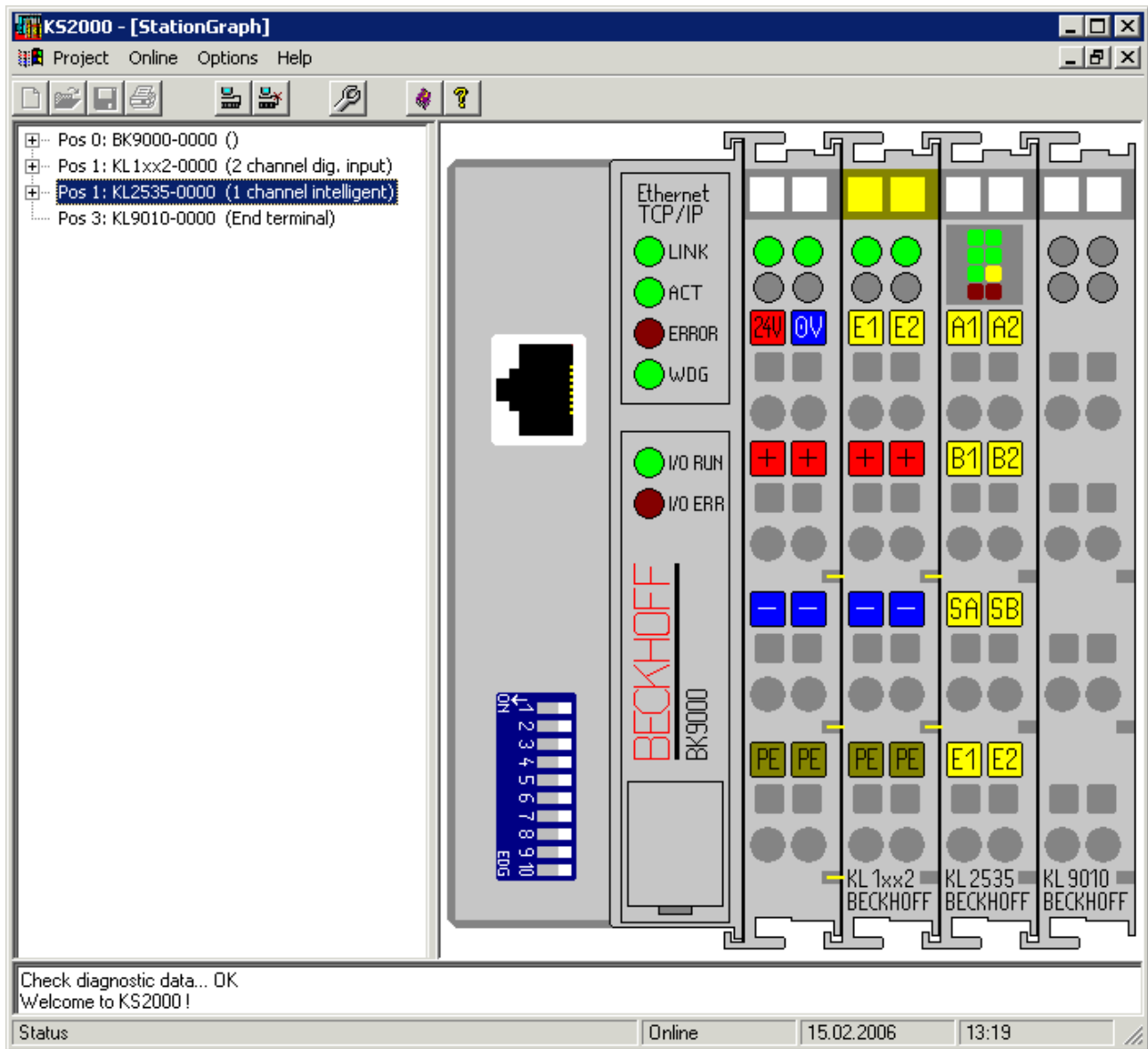

Fig. 22: Display of the fieldbus station in KS2000

The left-hand KS2000 window displays the terminals of the fieldbus station in a tree structure. The right-hand KS2000 window contains a graphic display of the fieldbus station terminals.

In the tree structure of the left-hand window, click on the plus-sign next to the terminal whose parameters you wish to change (item 2 in the example).

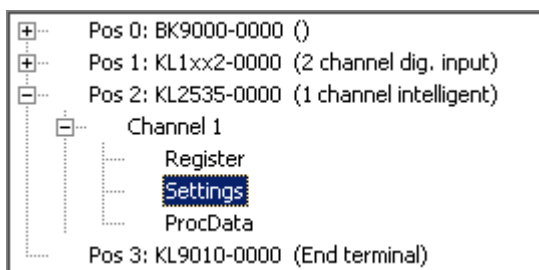

Fig. 23: KS2000 tree branches for channel 1 of the KL2535

For the KL2535, the branches *Register*, *Settings* and *ProcData* are displayed:

- Register [▶ 34] permits direct access to the registers of the KL2535.
- Under Settings [▶ 31] you find dialog boxes for parameterizing the KL2535.

- ProcData [▶ 35] displays the KL2535 process data.

4.3 Settings

Settings for parameterization of the KL2535 and KL2545.

Fig. 24: Settings via KS2000

Operation mode

Watchdog timer active (R32.2 [▶ 43])

Here you can deactivate the watchdog (default: active). If the pulse-width current terminal fails to receive any process data from the controller for 100 ms while the watchdog is active, the watchdog triggers and the valve is switched off.

User scaling (R32.0 [▶ 43])

You can activate user scaling here (the default is deactivated).

User switch-on value active (R32.8 [▶ 43])

You can activate the user switch-on value [▶ 32] here (the default is inactive).

Sign / amount representation (R32.3 [▶ 43])

You can activate the sign / amount representation here (the default is inactive).

Dithering active (R32.5 [▶ 43])

You can activate the [dithering \[▶ 15\]](#) here (the default is inactive).

Valve curve (R32.4 [▶ 43])

You can activate the [valve curve \[▶ 16\]](#) here (the default is inactive).

Process data ramps active (R32.6 [▶ 43])

You can activate the [process data ramps \[▶ 17\]](#) here (the default is inactive).

Register values**User offset (R33 [▶ 43])**

You can specify the offset for the user-scaling here (the default is 0).

User gain (R34 [▶ 43])

The gain for the user scaling can be set here (default: 4096_{dec}).

User switch-on value (R35 [▶ 43])

You can specify the offset for the user switch-on value for the speed here (the default is 0).

Max. output current (R36 [▶ 43])

You can specify the maximum output current here.

KL2535: The default is 1000 mA

KL2545: The default is 3,500 mA

Dithering frequency (R37 [▶ 44])

You can specify the frequency of the [dither \[▶ 15\]](#) here (the default is 0).

Dithering amplitude (R38 [▶ 44])

You can specify the amplitude of the [dither \[▶ 15\]](#) here (the default is 0).

Dithering switch-off ramp (R39 [▶ 44])

You can specify the switch-off ramp of the [dither \[▶ 15\]](#) here (the default is 0).

Overlap threshold value (R40 [▶ 44])

You can specify the threshold value of the [overlap region \[▶ 16\]](#) here (the default is 0).

Overlap output value (R41 [▶ 43])

You can specify the output value of the [overlap region \[▶ 16\]](#) here (the default is 0).

Bend threshold value (R42 [▶ 44])

You can specify the threshold value of the [bend compensation region \[▶ 16\]](#) here (the default is 0).

Bend region output value (R43 [▶ 44])

You can specify the output value of the [bend compensation region \[▶ 16\]](#) here (the default is 0). The I-component of the velocity control is attenuated towards the zero point. This register specifies the value from which the attenuation is activated.

Area compensation - threshold value (R44 [▶ 44])

You can specify the threshold value of the [area compensation region \[▶ 16\]](#) here (the default is 1000_{dec}).

Process data ramp (rising) (R45 [▶ 44])

You can specify the rising [process data ramp \[▶ 17\]](#) here (the default is 0_{dec}).

Process data ramp (falling) (R38 [▶ 43])

You can specify the falling [process data ramp \[▶ 17\]](#) here (the default is 0_{dec}).

4.4 Register

Under *Register* you can directly access the registers of the KL2535/KL2545. The meaning of the register is explained in the [register overview](#) [▶ 40].

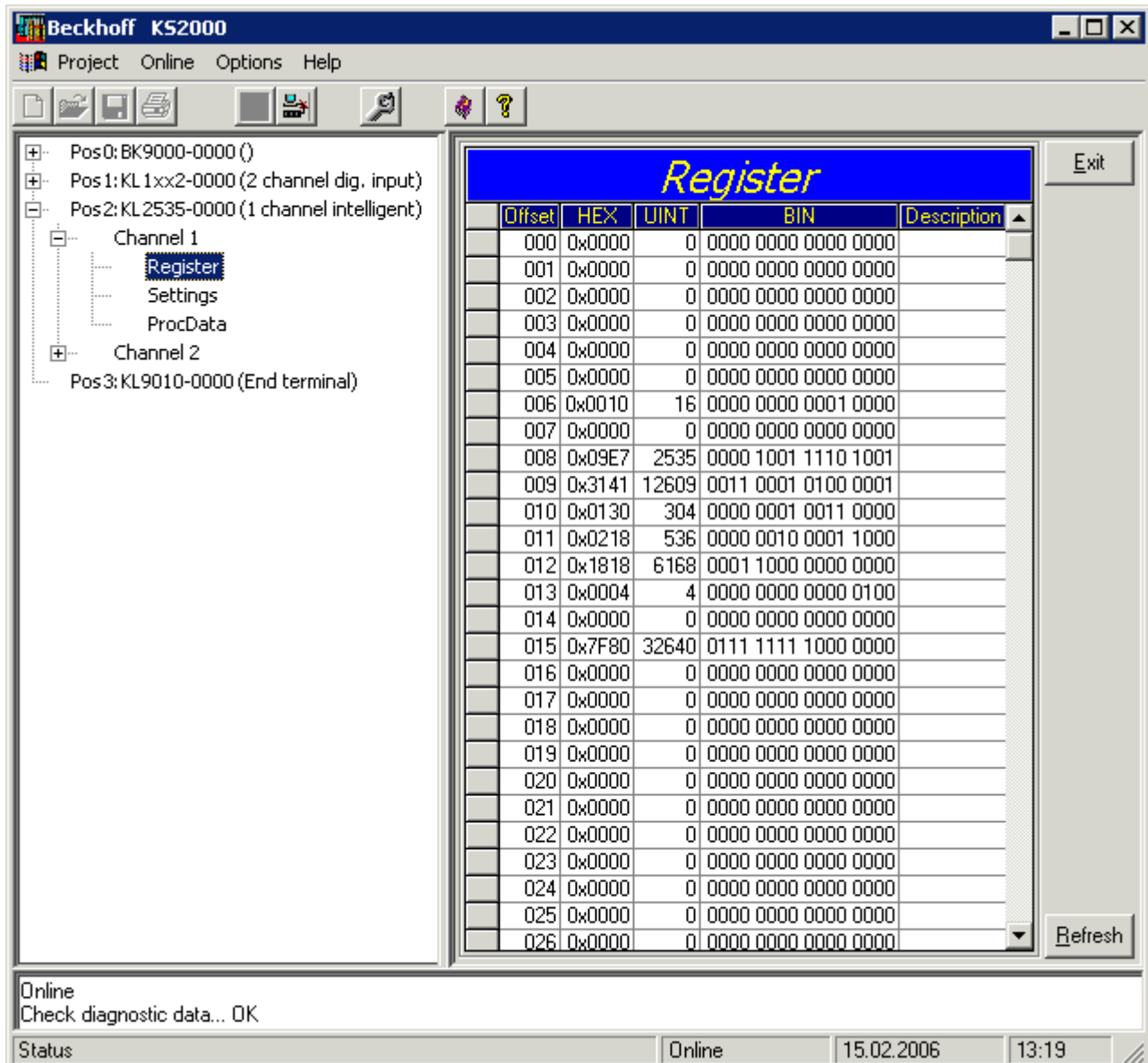

Fig. 25: Register view in KS2000

4.5 Process data

The Status byte (Status), the Control byte (Ctrl) and the process data (Data) are displayed in a tree structure under *ProcData*.

Pos	Type	I-Address	Value	Bitsize	O-Address	Value	Bitsize
2	KL2535-0000						
	Channel 1						
	Status	0.0	0x00	8			
	Data In	2.0	0x0000	16			
	Ctrl				0.0	0x00	8
	Data Out				2.0	0x0000	16
	Channel 2						
	Status	4.0	0x00	8			
	Data In	6.0	0x0000	16			
	Ctrl				4.0	0x00	8
	Data Out				6.0	0x0000	16

Fig. 26: ProcData

The reading glasses mark the data that are currently graphically displayed in the *History* field.

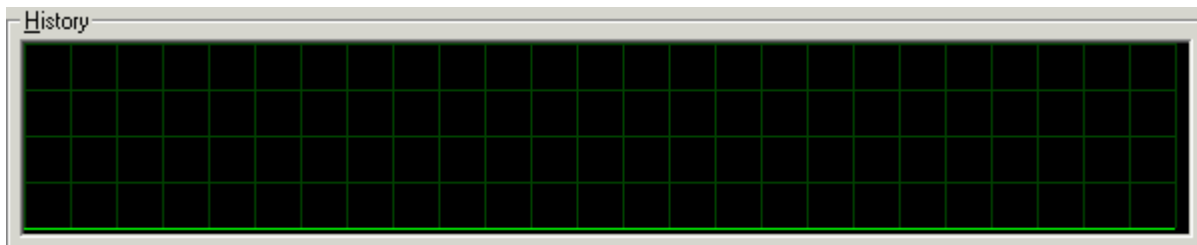

Fig. 27: History field

The current input values are displayed numerically in the *Value* field.

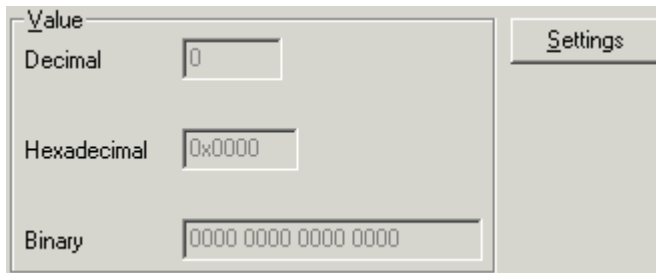

Fig. 28: Value field

Initial values can be modified through direct input or by means of the fader.

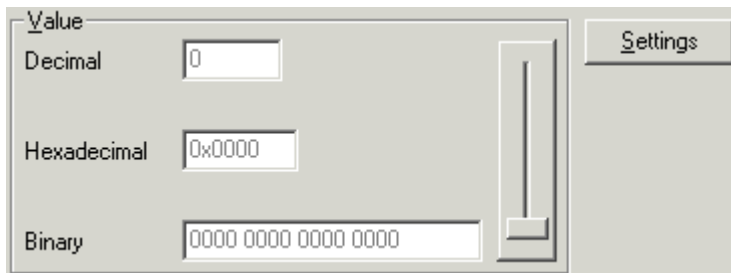



Fig. 29: Value field

 CAUTION	<p>Danger for persons, the environment or equipment!</p> <p>Note that changing initial values (forcing them) can have a direct effect on your automation application.</p> <p>Only modify these initial values if you are certain that the state of your equipment permits it, and that there will be no risk to people or to the machine!</p>
---	--

After pressing the *Settings* button you can set the format of the numerical display to hexadecimal, decimal or binary.

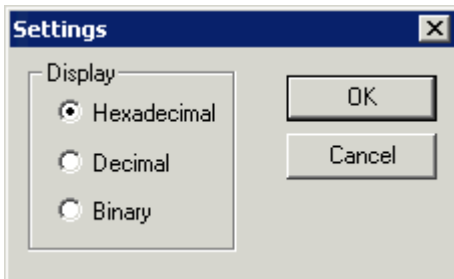

Fig. 30: Settings

5 Access from the user program

5.1 Process image

The KL2535 and KL2545 appear in the complex process image with at least 6 bytes of input and 6 bytes of output data. These are organized as follows:

Byte offset (without word alignment)	Byte offset (with word alignment*)	Format	Input data	Output data
0	0	Byte	SB1 [▶ 38]	CB1 [▶ 38]
1	2	Word	DataIN1	DataOUT1
3	4	Byte	SB2 [▶ 39]	CB2 [▶ 39]
4	6	Word	DataIN2	DataOUT2

The KL2535 and KL2545 appear in the complex process image with at least 6 bytes of output data. These are organized as follows:

Byte offset (without word alignment)	Byte offset (with word alignment*)	Format	Input data	Output data
0	0	Byte	-	CB1 [▶ 38]
1	2	Word	-	DataOUT1
3	4	Byte	-	CB2 [▶ 39]
4	6	Word	-	DataOUT2

*) Word alignment: The Bus Coupler places values on even byte addresses

Legend

SB n: status byte channel n

CB n: Control byte of channel n

DataIN n: Input word of channel n

DataOUT n: Output word of channel n



Note

Process image

It is not possible for the KL2535 or KL2545 to operate without control bytes, since the control bytes are required to enable the channels. Even if you adjust your bus coupler to the compact process image, the KL2535 and KL2545 will still be represented with their control bytes!

Process data

Output value	Output current
-32767 _{dec}	-100% of the maximum output current (see Register R36 [▶ 43])
0 _{dec}	0
+32767 _{dec}	+100% of the maximum output current (see Register R36 [▶ 43])

5.2 Control and status bytes

Channel 1

Process data mode

Control byte 1 (for process data mode)

Control byte 1 (CB1) is located in the [output image \[► 37\]](#), and is transmitted from the controller to the terminal.

Bit	CB1.7	CB1.6	CB1.5	CB1.4	CB1.3	CB1.2	CB1.1	CB1.0
Name	RegAccess	Reset	Enable	GetLatchData	enLatch FallEdge	enLatch RiseEdge	SetPos	enDithering

Legend

Bit	Name	Description
CB1.7	RegAccess	0 _{bin} Register communication off (process data mode)
CB1.6	Reset	1 _{bin} all errors that may have occurred are reset by setting this bit (rising edge)
CB1.5	Enable	1 _{bin} Enables channel 1
CB1.4	GetLatchData	0 _{bin} Show the current position in the input process data
		1 _{bin} Show the current latch value in the input process data
CB1.3	enLatch FallEdge	1 _{bin} External latch event is enabled (for latch inputs with falling edge, the terminal saves the current position)
CB1.2	enLatch RiseEdge	1 _{bin} External latch event is enabled (for latch inputs with rising edge, the terminal saves the current position) ATTENTION: Higher priority than CB1.3 !
CB1.1	SetPos	1 _{bin} Position value is set with register R1 [► 41] (rising edge)
CB1.0	enDithering	1 _{bin} Dithering is active (when R32.5 [► 43] =1)

Status byte 1 (for process data mode)

The status byte 1 (SB1) is located in the [input image \[► 37\]](#), and is transmitted from terminal to the controller.

Bit	SB1.7	SB1.6	SB1.5	SB1.4	SB1.3	SB1.2	SB1.1	SB1.0
Name	RegAccess	Error	Warning	Ready	LatchData	LatchValid	SetPos Ready	Input E1

Legend

Bit	Name	Description
SB1.7	RegAccess	0 _{bin} Acknowledgement for process data mode
SB1.6	Error	1 _{bin} An error has occurred (is displayed in the status word in register R0)
SB1.5	Warning	1 _{bin} The internal temperature has risen to more than 80 °C, or the power supply voltage has dropped.
SB1.4	Ready	0 _{bin} Motor control is disabled or an error has occurred (SB.6=1)
		1 _{bin} Motor control is enabled and no error has occurred (acknowledgement for enable, SB.6=0)
SB1.3	LatchData	0 _{bin} The current position is mapped into the input process data
		1 _{bin} The most recent latch value is mapped into the process data, provided a valid latch value exists (acknowledgement for GetLatchData)
SB1.2	LatchValid	1 _{bin} A latch event has occurred (when CB1.2=1 or CB1.3=1)
SB1.1	SetPos Ready	1 _{bin} The current position has been set (acknowledgement for SetPos)
SB1.0	Input E1	Status of input E1

Register communication

Control byte 1 (in register communication)

Control byte 1 (CB1) is located in the [output image \[▶ 37\]](#), and is transmitted from the controller to the terminal.

Bit	CB1.7	CB1.6	CB1.5	CB1.4	CB1.3	CB1.2	CB1.1	CB1.0
Name	RegAccess	R/W	Reg. no.					

Legend

Bit	Name	Description
CB1.7	RegAccess	1 _{bin} Register communication switched on
CB1.6	R/W	0 _{bin} Read access
		1 _{bin} Write access
CB1.5 to CB1.0	Reg. no.	Register number: Enter here the number of the register [▶ 40] that you wish - to read with input data word DataIn [▶ 37] , or - to write with output data word DataOut [▶ 37] .

Status byte 1 (in register communication)

The status byte 1 (SB1) is located in the [input image \[▶ 37\]](#), and is transmitted from terminal to the controller.

Bit	SB1.7	SB1.6	SB1.5	SB1.4	SB1.3	SB1.2	SB1.1	SB1.0
Name	RegAccess	R/W	Reg. no.					

Legend

Bit	Name	Description
SB1.7	RegAccess	1 _{bin} Acknowledgement for register access
SB1.6	R	0 _{bin} Read access
SB1.5 to SB1.0	Reg. no.	Number of the register that was read or written.

Channel 2

The control and status bytes of channel 2 (CB2 and SB2) have the same structure as the control and status bytes of channel 1.

5.3 Register overview

The registers serve the parameterization of the pulse width current terminal. They can be read or written by means of register communication.

Register no.	Comment	Default value	R/W	Memory		
R0 [▶ 41]	Status word	0x0000	0 _{dec}	R	RAM	
R1 [▶ 41]	Set position (only on the KL2545)	0x0000	0 _{dec}	R/W	RAM	
R2 [▶ 41]	Coil voltage (only on the KL2545)	0x0000	0 _{dec}	R	RAM	
R3 [▶ 41]	Power supply voltage (only on the KL2545)	e.g. 0x0030	e.g. 48 _{dec}	R	RAM	
R4	reserved	-	-	-	-	
R5 [▶ 41]	Temperature (only on the KL2545)	e.g. 0x0023	e.g. 35 _{dec}	R	RAM	
R6 [▶ 41]	Status byte	e.g. 0x0010	e.g. 16 _{dec}	R	RAM	
R7 [▶ 42]	Command register	0x0000	0 _{dec}	R/W	RAM	
R8 [▶ 42]	Terminal type	KL2535:	0x09E7	2535 _{dec}	R	ROM
		KL2545:	0x09F1	2545 _{dec}		
R9 [▶ 42]	Firmware version	e.g. 0x3141	e.g. 1A _{ASCII}	R	ROM	
R10	Multiplex shift register	0x0130	304 _{dec}	R	ROM	
R11	Signal channels	0x0218	536 _{dec}	R	ROM	
R12	Minimum data length	0x1818	6168 _{dec}	R	ROM	
R13	Data structure	0x0004	4 _{dec}	R	ROM	
R14	reserved	-	-	-	-	
R15	Alignment register	0x7F80	32640 _{dec}	R/W	RAM	
R16 [▶ 42]	Hardware version number	e.g. 0x0000	e.g. 0 _{dec}	R/W	EEPROM	
R17	reserved	-	-	-	-	
...	
R30	reserved	-	-	-	-	
R31 [▶ 43]	Code word register	0x0000	0 _{dec}	R/W	RAM	
R32 [▶ 43]	Feature register	0x0000	0 _{dec}	R/W	EEPROM	
R33 [▶ 43]	User scaling - offset	0x1000	4096 _{dec}	R/W	EEPROM	
R34 [▶ 43]	User scaling - gain	0x0000	0 _{dec}	R/W	EEPROM	
R35 [▶ 43]	User's switch-on value	0x0000	0 _{dec}	R/W	EEPROM	
R36 [▶ 43]	Maximum output current	KL2535:	0x03E8	1000 _{dec}	R/W	EEPROM
		KL2545:	0x0DAC	3500 _{dec}		
R37 [▶ 44]	Dithering - Frequency	0x0000	0 _{dec}	R/W	EEPROM	
R38 [▶ 44]	Dithering amplitude	0x0000	0 _{dec}	R/W	EEPROM	
R39 [▶ 44]	Dithering - Switch-off ramp	0x0000	0 _{dec}	R/W	EEPROM	
R40 [▶ 44]	Overlap threshold value	0x0000	0 _{dec}	R/W	EEPROM	
R41 [▶ 44]	Overlap output value	0x0000	0 _{dec}	R/W	EEPROM	
R42 [▶ 44]	Bend compensation - threshold value	0x0000	0 _{dec}	R/W	EEPROM	
R43 [▶ 44]	Bend compensation - output value	0x0000	0 _{dec}	R/W	EEPROM	
R44 [▶ 44]	Area compensation - threshold value	0x03E8	1000 _{dec}	R/W	EEPROM	
R45 [▶ 44]	Process data ramp (rising)	0x0000	0 _{dec}	R/W	EEPROM	
R46 [▶ 45]	Process data ramp (falling)	0x0000	0 _{dec}	R/W	EEPROM	
R47	reserved					
R63	reserved					

5.4 Register description

All registers can be read or written via register communication. They are used for parameterizing the terminal.

R0: Status word

The status word contains information about internal states, and provides an indication of errors that have occurred.

Bit	R0.15	R0.14	R0.13	R0.12	R0.11	R0.10	R0.9	R0.8
Name	-	NoControlPower	OpenLoad	OverCurrent	UnderVoltage	-	LowVoltage	OverTemperature

Bit	R0.7	R0.6	R0.5	R0.4	R0.3	R0.2	R0.1	R0.0
Name	-	-	-	-	-	-	-	-

Legend

Bit	Name	Description
R0.15	-	reserved
R0.14	NoControlPower	1 _{bin} The 24 V control voltage is not present at the power contacts
R0.13	OpenLoad	1 _{bin} Open load / broken wire
R0.12	OverCurrent	1 _{bin} Overcurrent in the driver stage
R0.11	UnderVoltage	1 _{bin} Supply voltage less than 7 V (only on the KL2545)
R0.10	-	reserved
R0.9	LowVoltage	1 _{bin} The supply voltage is 10 V less than the switch-on voltage (only on the KL2545)
R0.8	OverTemperature	1 _{bin} The internal temperature of the terminal is greater than 80°C (see R5 [▶ 41]) (only on the KL2545)
R0.0-R0.7	-	reserved

R1: Set position

You can specify the desired position, with which the terminal is to be loaded, here.

R2: Coil voltage

You can read the coil voltage here. The unit is 1 mV (for example: 4800 = 48 V).

R3: Supply voltage

You can read the power supply voltage here. The unit is 1 mV (for example: 4800 = 48 V).

R5: Temperature register

The internal temperature of the terminal can be read, in °C, through register R5. The terminal will set bit SB.5 [▶ 38] in the status byte as a warning if the temperature exceeds the threshold of 80°C. When the temperature falls back below 60°C, bit SB.5 [▶ 38] will automatically be reset.

R6: Status byte

The status byte of the relevant channel is mapped here in addition.

R7: Command register**Note****User code word**

For the following commands to be executed, it is first necessary for the user code word, 0x1235, to be entered into register R31 [► 43].

Command 0x7000: Restore Factory Settings

Entering 0x7000 in register R7 restores the factory settings for the following registers of both channels:

R32: 0_{dec}R33: 0_{dec}R34: 4096_{dec}R35: 0_{dec}R36: KL2535: 1000_{dec}, KL2545: 3500_{dec}R37: 0_{dec}R38: 0_{dec}R39: 0_{dec}R40: 0_{dec}R41: 0_{dec}R42: 0_{dec}R43: 0_{dec}R44: 1000_{dec}R45: 0_{dec}R46: 0_{dec}**Note****Complete restore**

The Restore Factory Settings command resets **both** channels in the pulse-width current terminal to the factory settings simultaneously, regardless of which register set it is called from!

Command 0x8000: Software Reset

Entering 0x8000 in register R7 initiates a full software reset for the terminal. All internal variables (positions, latched values, errors etc.) are cleared or are set to defined values that are read from the EEPROM. The internal circuits (D/A converter, output driver) are reinitialized during a software reset.

**CAUTION****Software reset!**

Power is removed from the output stage during a software reset. Ensure that your system state permits this and that hazards for persons or machinery have been ruled out!

R8: Terminal type

The terminal identifier is contained in register R8:

KL2535: 0x09E7 (2535_{dec})KL2545: 0x09F1 (2545_{dec})**R9: Firmware version**

Register R9 contains the ASCII coding of the terminal's firmware version, e.g. **0x3141** = '1A'. The '0x31' corresponds here to the ASCII character '1', while the '0x41' represents the ASCII character 'A'.

This value cannot be changed.

R16: Hardware version number

Register R16 contains the hardware version of the terminal.

R31: Code word register

If you write values into the user registers without first entering the user code word (0x1235) into the code word register, the terminal will not accept the supplied data. The code word is reset if the terminal is restarted.

R32: Feature register

The feature register specifies the terminal's configuration.

Bit	R32.15	R32.14	R32.13	R32.12	R32.11	R32.10	R32.9	R32.8
Name	disMixedDecay	-	-	-	-	-	-	enUserStartValue

Bit	R32.7	R32.6	R32.5	R32.4	R32.3	R32.2	R32.1	R32.0
Name	-	enRamps	enDithering	enValveCurve	enAverageNotation	disWatchdog	enManuScale	enUserScale

Legend

Bit	Name	Description	default
R32.15	disMixedDecay	1 _{bin} Mixed Decay is deactivated	0 _{bin}
R32.14-R32.9	-	reserved	
R32.8	enUserStartValue	1 _{bin} User switch-on value active (see R35 [▶ 43])	0 _{bin}
R32.7	-	reserved	
R32.6	enRamps	1 _{bin} Process data ramps [▶ 17] are active (see R45 [▶ 44] + R46 [▶ 45])	0 _{bin}
R32.5	enDithering	1 _{bin} Dithering [▶ 15] is active (see R37 [▶ 44], R38 [▶ 44] + R39 [▶ 44]); bit CB1.0 [▶ 38] = 1 must be set in addition	0 _{bin}
R32.4	enValveCurve	1 _{bin} Valve curve [▶ 16] is active (see R40 [▶ 44], R41 [▶ 44], R42 [▶ 44], R43 [▶ 44] + R44 [▶ 44])	0 _{bin}
R32.3	enAverageNotation	0 _{bin} Two's complement representation is active	0 _{bin}
		1 _{bin} Signed amount representation active	
R32.2	disWatchdog	1 _{bin} Internal 100 ms watchdog deactivated	0 _{bin}
R32.1	enManuScale	1 _{bin} Manufacturer scaling is active	0 _{bin}
R32.0	enUserScale	1 _{bin} User scaling active (see R33 [▶ 43]+ R34 [▶ 43])	0 _{bin}

R33: User scaling - offset

If user-scaling is active (R32.0 [▶ 43]=1) this register specifies the offset for the user-scaling.

R34: User scaling - gain

If user-scaling is active (R32.0 [▶ 43]=1) this register specifies the gain for the user-scaling.

R35: User's switch-on value

If the user switch-on value is active (R32.8 [▶ 43]=1) and if the activated watchdog (R32.2 [▶ 43]=0_{bin}) triggers following a fieldbus or terminal bus error continuing for 100 ms, the output will be set to this value.

R36: Maximum output current

This register specifies the maximum output current. The unit is 1 mA (for example: 1000_{dec} = 1 A).

KL2535: maximum 1000 mA (default: 1000_{dec})

KL2545: maximum 3500 mA (default: 3500_{dec})

R37: Dithering - Frequency

When Dithering [▶ 15] is active (R32.5 [▶ 43]=1) this register specifies the frequency of the dither. Values from 10 to 500 Hz are permitted. The unit is 1 Hz. (Example: $100_{\text{dec}} = 100$ Hz).

R38: Dithering amplitude

When Dithering [▶ 15] is active (R32.5 [▶ 43]=1) this register specifies the amplitude of the dither. The configured value refers to the set output current in register R36 [▶ 43]. The unit is 1% (for example: $10_{\text{dec}} = 10\%$).

R39: Dithering - Switch-off ramp

When Dithering [▶ 15] is active (R32.5 [▶ 43]=1) this register specifies the switch-off ramp of the dither. The unit is 1 ms (for example: $100_{\text{dec}} = 100$ ms).

R40: Overlap - Threshold value (valve curve)

When the valve curve [▶ 16] is active (R32.4 [▶ 43]=1) this register specifies the threshold value for the overlap region. The unit is 0.1%, and is expressed with reference to the final process data value (for example: $100_{\text{dec}} = 10\%$).

R41: Overlap - Output value (valve curve)

When the valve curve [▶ 16] is active (R32.4 [▶ 43]=1) this register specifies the output value for the overlap region. The configured value refers to the set output current in register R36 [▶ 43]. The unit is 0.1% (for example: $100_{\text{dec}} = 10\%$).

R42: Bend compensation - Threshold value (valve curve)

When the valve curve [▶ 16] is active (R32.4 [▶ 43]=1) this register specifies the threshold value for the bend compensation region. The unit is 0.1%, and is expressed with reference to the final process data value (for example: $100_{\text{dec}} = 10\%$).

R43: Bend compensation - Output value (valve curve)

When the valve curve [▶ 16] is active (R32.4 [▶ 43]=1) this register specifies the output value for the bend compensation region. The configured value refers to the set output current in register R36 [▶ 43]. The unit is 0.1% (for example: $100_{\text{dec}} = 10\%$).

R44: Area compensation - Threshold value (valve curve)

When the valve curve [▶ 16] is active (R32.4 [▶ 43]=1) this register specifies the threshold value for the area compensation region. The unit is 0.1%, and is expressed with reference to the final process data value (for example: $100_{\text{dec}} = 10\%$).

R45: Process data ramp (rising)

When the process data ramps are active (R32.6 [▶ 43]=1), this register specifies the rising process data ramp [▶ 17]. The unit is 1 ms, and is expressed with reference to the final process data value (for example: $100_{\text{dec}} = 100$ ms).

R46: Process data ramp (falling)

When the process data ramps are active (R32.6 [▶ 43]=1), this register specifies the falling process data ramp [▶ 17].

The unit is 1 ms, and is expressed with reference to the final process data value (for example: 100_{dec} = 100 ms).

5.5 Examples of Register Communication

The numbering of the bytes in the examples corresponds to the display without word alignment.

5.5.1 Example 1: reading the firmware version from Register 9 of a terminal

Byte 0: Control byte	Byte 1: DataOUT1, high byte	Byte 2: DataOUT1, low byte
0x89 (1000 1001 _{bin})	0xXX	0xXX

Explanation:

- Bit 0.7 set means: Register communication switched on.
- Bit 0.6 not set means: reading the register.
- Bits 0.5 to 0.0 specify the register number 9 with 00 1001_{bin}.
- The output data word (byte 1 and byte 2) has no meaning during read access. To change a register, write the required value into the output word.

Byte 0: Status byte	Byte 1: DataIN1, high byte	Byte 2: DataIN1, low byte
0x89	0x33	0x41

Explanation:

- The terminal returns the value of the control byte as a receipt in the status byte.
- The terminal returns the firmware version 0x3341 in the input data word (byte 1 and byte 2). This is to be interpreted as an ASCII code:
 - ASCII code 0x33 represents the digit 3
 - ASCII code 0x41 represents the letter A
 The firmware version is thus 3A.

5.5.2 Example 2: Writing to a user register

 Note	<p>Code word</p> <p>In normal mode all user registers are read-only with the exception of Register 31. In order to deactivate this write protection you must write the code word (0x1235) into Register 31. If a value other than 0x1235 is written into Register 31, write protection is reactivated. Please note that changes to a register only become effective after restarting the terminal (power-off/power-on).</p>
--	--

I. Write the code word (0x1235) into Register 31.

Byte 0: Control byte	Byte 1: DataOUT1, high byte	Byte 2: DataOUT1, low byte
0xDF (1101 1111 _{bin})	0x12	0x35

Explanation:

- Bit 0.7 set means: Register communication switched on.

- Bit 0.6 set means: writing to the register.
- Bits 0.5 to 0.0 specify the register number 31 with 01 1111_{bin}.
- The output data word (byte 1 and byte 2) contains the code word (0x1235) for deactivating write protection.

Byte 0: Status byte	Byte 1: DataIN1, high byte	Byte 2: DataIN1, low byte
0x9F (1001 1111 _{bin})	0xXX	0xXX

Explanation:

- The terminal returns a value as a receipt in the status byte that differs only in bit 0.6 from the value of the control byte.
- The input data word (byte 1 and byte 2) is of no importance after the write access. Any values still displayed are invalid!

II. Read Register 31 (check the set code word)

Byte 0: Control byte	Byte 1: DataOUT1, high byte	Byte 2: DataOUT1, low byte
0x9F (1001 1111 _{bin})	0xXX	0xXX

Explanation:

- Bit 0.7 set means: Register communication switched on.
- Bit 0.6 not set means: reading the register.
- Bits 0.5 to 0.0 specify the register number 31 with 01 1111_{bin}.
- The output data word (byte 1 and byte 2) has no meaning during read access.

Byte 0: Status byte	Byte 1: DataIN1, high byte	Byte 2: DataIN1, low byte
0x9F (1001 1111 _{bin})	0x12	0x35

Explanation:

- The terminal returns the value of the control byte as a receipt in the status byte.
- The terminal returns the current value of the code word register in the input data word (byte 1 and byte 2).

III. Write to Register 32 (change contents of the feature register)

Byte 0: Control byte	Byte 1: DataIN1, high byte	Byte 2: DataIN1, low byte
0xE0 (1110 0000 _{bin})	0x00	0x02

Explanation:

- Bit 0.7 set means: Register communication switched on.
- Bit 0.6 set means: writing to the register.
- Bits 0.5 to 0.0 indicate register number 32 with 10 0000_{bin}.
- The output data word (byte 1 and byte 2) contains the new value for the feature register.



CAUTION

Observe the register description!

The value of 0x0002 given here is just an example! The bits of the feature register change the properties of the terminal and have a different meaning, depending on the type of terminal. Refer to the description of the feature register of your terminal (chapter "Register description") regarding the meaning of the individual bits before changing the values.

Byte 0: Status byte	Byte 1: DataIN1, high byte	Byte 2: DataIN1, low byte
0xA0 (1010 0000 _{bin})	0xXX	0xXX

Explanation:

- The terminal returns a value as a receipt in the status byte that differs only in bit 0.6 from the value of the control byte.
- The input data word (byte 1 and byte 2) is of no importance after the write access. Any values still displayed are invalid!

IV. Read Register 32 (check changed feature register)

Byte 0: Control byte	Byte 1: DataOUT1, high byte	Byte 2: DataOUT1, low byte
0xA0 (1010 0000 _{bin})	0xXX	0xXX

Explanation:

- Bit 0.7 set means: Register communication switched on.
- Bit 0.6 not set means: reading the register.
- Bits 0.5 to 0.0 indicate register number 32 with 10 0000_{bin}.
- The output data word (byte 1 and byte 2) has no meaning during read access.

Byte 0: Status byte	Byte 1: DataIN1, high byte	Byte 2: DataIN1, low byte
0xA0 (1010 0000 _{bin})	0x00	0x02

Explanation:

- The terminal returns the value of the control byte as a receipt in the status byte.
- The terminal returns the current value of the feature register in the input data word (byte 1 and byte 2).

V. Write Register 31 (reset code word)

Byte 0: Control byte	Byte 1: DataOUT1, high byte	Byte 2: DataOUT1, low byte
0xDF (1101 1111 _{bin})	0x00	0x00

Explanation:

- Bit 0.7 set means: Register communication switched on.
- Bit 0.6 set means: writing to the register.
- Bits 0.5 to 0.0 specify the register number 31 with 01 1111_{bin}.
- The output data word (byte 1 and byte 2) contains 0x0000 for reactivating write protection.

Byte 0: Status byte	Byte 1: DataIN1, high byte	Byte 2: DataIN1, low byte
0x9F (1001 1111 _{bin})	0xXX	0xXX

Explanation:

- The terminal returns a value as a receipt in the status byte that differs only in bit 0.6 from the value of the control byte.
- The input data word (byte 1 and byte 2) is of no importance after the write access. Any values still displayed are invalid!

6 Appendix

6.1 Support and Service

Beckhoff and their partners around the world offer comprehensive support and service, making available fast and competent assistance with all questions related to Beckhoff products and system solutions.

Beckhoff's branch offices and representatives

Please contact your Beckhoff branch office or representative for local support and service on Beckhoff products!

The addresses of Beckhoff's branch offices and representatives round the world can be found on her internet pages:

<http://www.beckhoff.com>

You will also find further documentation for Beckhoff components there.

Beckhoff Headquarters

Beckhoff Automation GmbH & Co. KG

Huelshorstweg 20
33415 Verl
Germany

Phone:	+49(0)5246/963-0
Fax:	+49(0)5246/963-198
e-mail:	info@beckhoff.com

Beckhoff Support

Support offers you comprehensive technical assistance, helping you not only with the application of individual Beckhoff products, but also with other, wide-ranging services:

- support
- design, programming and commissioning of complex automation systems
- and extensive training program for Beckhoff system components

Hotline:	+49(0)5246/963-157
Fax:	+49(0)5246/963-9157
e-mail:	support@beckhoff.com

Beckhoff Service

The Beckhoff Service Center supports you in all matters of after-sales service:

- on-site service
- repair service
- spare parts service
- hotline service

Hotline:	+49(0)5246/963-460
Fax:	+49(0)5246/963-479
e-mail:	service@beckhoff.com

List of illustrations

Fig. 1	KL2535	7
Fig. 2	KL2535 - LEDs	9
Fig. 3	KL2545	10
Fig. 4	KL2545 - LEDs	12
Fig. 5	Operation at load with adequate inductance	13
Fig. 6	Operation at load inadequate inductance (near ohmic).....	13
Fig. 7	Frequency - f / Amplitude - i.....	15
Fig. 8	Switch-off ramp - t.....	16
Fig. 9	Valve curve	17
Fig. 10	Process data ramps.....	17
Fig. 11	Attaching on mounting rail	18
Fig. 12	Disassembling of terminal.....	19
Fig. 13	Power contact on left side.....	20
Fig. 14	Recommended distances for standard installation position	21
Fig. 15	Standard wiring.....	22
Fig. 16	Pluggable wiring	22
Fig. 17	High Density Terminals.....	22
Fig. 18	Mounting a cable on a terminal connection	23
Fig. 19	KL2535 Connection	25
Fig. 20	KL2545 Connection	26
Fig. 21	KS2000 configuration software.....	28
Fig. 22	Display of the fieldbus station in KS2000	30
Fig. 23	KS2000 tree branches for channel 1 of the KL2535.....	30
Fig. 24	Settings via KS2000	31
Fig. 25	Register view in KS2000.....	34
Fig. 26	ProcData.....	35
Fig. 27	History field	35
Fig. 28	Value field	35
Fig. 29	Value field	35
Fig. 30	Settings.....	36