

Documentation

KL3311, KL3312, KL3314 and KL3302

Single, Dual- and Four-Channel Analog Input Terminals for Thermocouples

Version: 4.1
Date: 2019-06-05

BECKHOFF

Table of contents

1 Foreword	5
1.1 Notes on the documentation.....	5
1.2 Safety instructions	6
1.3 Documentation issue status	7
2 Product overview	8
2.1 Introduction.....	8
2.2 Technical Data.....	9
2.3 Basic function principles	9
3 Mounting and wiring	13
3.1 Instructions for ESD protection.....	13
3.2 Installation on mounting rails	13
3.3 Installation instructions for enhanced mechanical load capacity	17
3.4 Connection	17
3.4.1 Connection system	17
3.4.2 Wiring.....	20
3.4.3 Shielding	21
3.5 KL3311 - Connection and LED description	22
3.6 KL3312, KL3302 - Connection and LED Description	23
3.7 KL3314 - Connection and LED description	24
3.8 Connection of ground, shield und earthing.....	25
3.9 ATEX - Special conditions (standard temperature range).....	26
3.10 ATEX Documentation	27
4 KS2000 Configuration Software	28
4.1 KS2000 - Introduction.....	28
4.2 Sample program for KL register communication via EtherCAT on KL3314 exemplary.....	29
5 Access from the user program	32
5.1 KL331x, KL3302 - Terminal Configuration	32
5.2 Mapping in the Bus Coupler	33
5.2.1 KL3311 - Default Mapping.....	34
5.2.2 KL3312 (KL3302) - Default Mapping	35
5.2.3 KL3314 - Default Mapping	36
5.3 Register overview	37
5.4 Register description.....	37
5.5 Control and status byte.....	41
5.5.1 Register communication	43
5.6 Examples of Register Communication	44
5.6.1 Example 1: reading the firmware version from Register 9.....	44
5.6.2 Example 2: Writing to an user register.....	45
6 Appendix	48
6.1 Support and Service	48

1 Foreword

1.1 Notes on the documentation

Intended audience

This description is only intended for the use of trained specialists in control and automation engineering who are familiar with the applicable national standards.

It is essential that the documentation and the following notes and explanations are followed when installing and commissioning these components.

It is the duty of the technical personnel to use the documentation published at the respective time of each installation and commissioning.

The responsible staff must ensure that the application or use of the products described satisfy all the requirements for safety, including all the relevant laws, regulations, guidelines and standards.

Disclaimer

The documentation has been prepared with care. The products described are, however, constantly under development.

We reserve the right to revise and change the documentation at any time and without prior announcement.

No claims for the modification of products that have already been supplied may be made on the basis of the data, diagrams and descriptions in this documentation.

Trademarks

Beckhoff®, TwinCAT®, EtherCAT®, EtherCAT P®, Safety over EtherCAT®, TwinSAFE®, XFC® and XTS® are registered trademarks of and licensed by Beckhoff Automation GmbH.

Other designations used in this publication may be trademarks whose use by third parties for their own purposes could violate the rights of the owners.

Patent Pending

The EtherCAT Technology is covered, including but not limited to the following patent applications and patents: EP1590927, EP1789857, DE102004044764, DE102007017835 with corresponding applications or registrations in various other countries.

The TwinCAT Technology is covered, including but not limited to the following patent applications and patents: EP0851348, US6167425 with corresponding applications or registrations in various other countries.



EtherCAT® is registered trademark and patented technology, licensed by Beckhoff Automation GmbH, Germany.

Copyright

© Beckhoff Automation GmbH & Co. KG, Germany.

The reproduction, distribution and utilization of this document as well as the communication of its contents to others without express authorization are prohibited.

Offenders will be held liable for the payment of damages. All rights reserved in the event of the grant of a patent, utility model or design.

1.2 Safety instructions

Safety regulations

Please note the following safety instructions and explanations!
Product-specific safety instructions can be found on following pages or in the areas mounting, wiring, commissioning etc.

Exclusion of liability

All the components are supplied in particular hardware and software configurations appropriate for the application. Modifications to hardware or software configurations other than those described in the documentation are not permitted, and nullify the liability of Beckhoff Automation GmbH & Co. KG.

Personnel qualification

This description is only intended for trained specialists in control, automation and drive engineering who are familiar with the applicable national standards.

Description of instructions

In this documentation the following instructions are used.
These instructions must be read carefully and followed without fail!

DANGER

Serious risk of injury!

Failure to follow this safety instruction directly endangers the life and health of persons.

WARNING

Risk of injury!

Failure to follow this safety instruction endangers the life and health of persons.

CAUTION

Personal injuries!

Failure to follow this safety instruction can lead to injuries to persons.

NOTE

Damage to environment/equipment or data loss

Failure to follow this instruction can lead to environmental damage, equipment damage or data loss.



Tip or pointer

This symbol indicates information that contributes to better understanding.

1.3 Documentation issue status

Version	Comment
4.1	<ul style="list-style-type: none"> Supported sensor types corrected
4.0	<ul style="list-style-type: none"> Migration Update Technical data Sample program added to the chapter <i>KS2000 Configuration Software</i> Structural update Chapters <i>KS2000 configuration software</i> and <i>Access from the user program</i> added

Firmware (FW) and hardware (HW) versions

Documen- tation, Version	KL3311		KL3302*		KL3312		KL3314	
	FW	HW	FW	HW	FW	HW	FW	HW
4.1	3G	08	3B	04	3H	07	3D	04
4.0	3G	08	3B	04	3H	07	3D	04

*) KL3302 is no longer available and was replaced with KL3312.

The firmware and hardware versions (delivery state) of the terminal can be found in the serial number printed on the side.

Syntax of the serial number

Structure of the serial number: WW YY FF HH

WW - week of production (calendar week)

YY - year of production

FF - firmware version

HH - hardware version

Example with ser. no.: 35 04 1B 01:

35 - week of production 35

04 - year of production 2004

1B - firmware version 1B

01 - hardware version 01

2 Product overview

2.1 Introduction

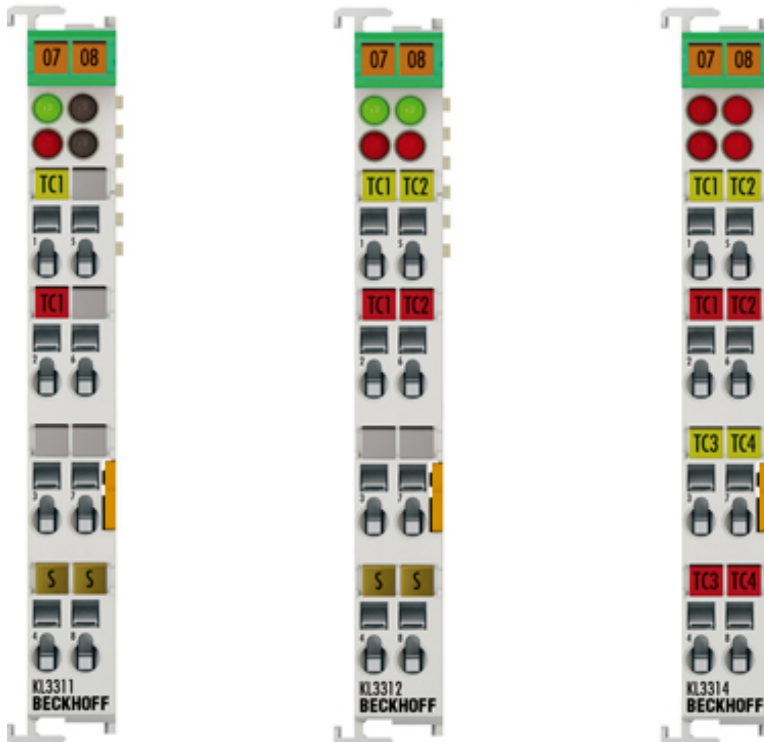

Fig. 1: KL3311, KL3312 and KL3314

The KL331x analog input terminals allow the direct connection of thermocouples. The circuit of the Bus Terminals can operate thermocouples using 2-wire technique. Linearization over the full temperature range is realized with the aid of a microprocessor. The temperature range can be selected freely. The error LEDs indicates a broken wire. Compensation for the cold junction is made through an internal temperature measurement at the terminals. mV measurement is also possible with the KL331x terminals.

KL3302 is no longer available and was replaced with KL3312.

2.2 Technical Data

Technical data	KL3311	KL3302*	KL3312	KL3314
Number of inputs	1	2		4
Power supply for the electronics	via the K-bus			
Thermocouple sensor type	Types B, E, J, K, L, N, R, S, T, U, mV measurement (default setting is type K)			
Connection technology	2-wire			
Temperature range	In each case within the defined range of the sensor (preset: type K, -100 °C to 1370 °C)			
Resolution	0.1 °C per digit			
Open-circuit recognition	yes	no	yes	yes
Conversion time	~ 200 ms	~ 250 ms		
Measuring error (total measuring range)	< ±0.5 % of the full scale value			
Electrical isolation	500 V (K-bus / signal voltage)			
Current consumption K-bus	typically 65 mA			
Bit width in the K-bus I/O	Input: 1 x 16 bits of data (1 x 8 bits control/status optional)	Input: 2 x 16 bits of data (2 x 8 bits control/status optional)		Input: 4 x 16 bits of data (4 x 8 bits control/status optional)
Configuration	No address or configuration settings			
Weight	approx. 70 g			
Dimensions (W x H x D)	approx. 15 mm x 100 mm x 70 mm (width aligned: 12 mm)			
Mounting [▶ 13]	on 35 mm mounting rail according to EN 60715			
Permissible ambient temperature range during operation	0 °C ... + 55 °C			
Permissible ambient temperature range during storage	-25 °C ... + 85 °C			
Permissible relative air humidity	95 %, no condensation			
Vibration / shock resistance	conforms to EN 60068-2-6 / EN 60068-2-27, see also Installation instructions for enhanced mechanical load capacity [▶ 17]			
EMC immunity / emission	conforms to EN 61000-6-2 / EN 61000-6-4			
Protection class	IP20			
Installation position	variable			
Approval	CE, cULus, ATEX [▶ 26]	-	CE, cULus, ATEX [▶ 26]	CE, cULus, ATEX [▶ 26], GL

*) KL3302 is no longer available and was replaced with KL3312.

2.3 Basic function principles

The thermocouple terminals can evaluate thermocouples of the types B, E, J, K, L, N, R, S, T and U. The characteristic curves are linearized and the reference temperature determined directly within the terminal. Temperatures are output in 1/10°C, for example (device-dependent). The terminal is fully configurable via the Bus Coupler or the control system. Different output formats may be selected or own scaling activated. In addition, linearization of the characteristic curve and determination and calculation of the reference temperature (temperature at the terminal connection contacts) can be switched off.

Measuring principle of the thermocouple

Thermocouples can be classified as active transducers. They exploit the thermo-electric effect (Seebeck, Peltier, Thomson). A voltage referred to as thermovoltage occurs over the length of a cable with different temperatures at both ends. It is an unambiguous function of the temperature and the material. In a "TC element" this effect is utilized by operating two different conductor materials in parallel (s. [fig \[▶ 10\]](#).)

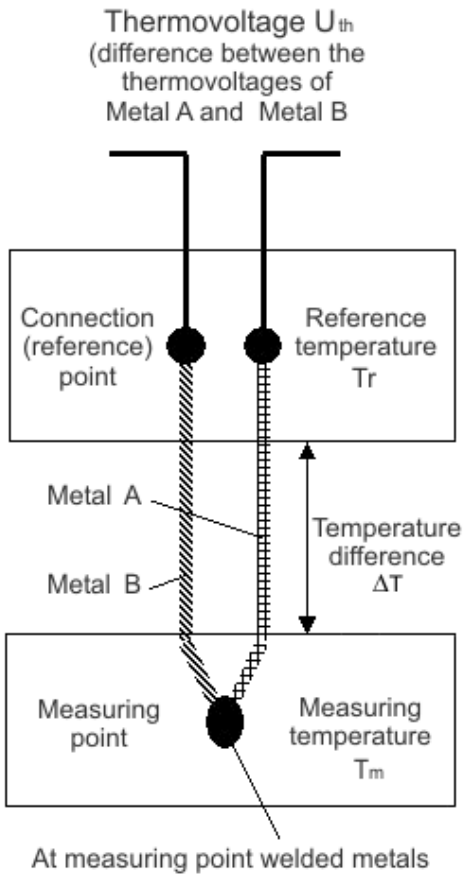

Fig. 2: Principle of the thermocouple

Example:

In the following example, the voltage U_{th} is given which is present at a type-K thermocouple at the temperature T_m .

$$U_{th} = (k_{NiCr} - k_{Ni}) \times \Delta T$$

with

$$\Delta T = T_m - T_v$$

A type-K thermocouple consists of a junction of a nickel-chrome alloy and nickel, where k_{NiCr} and k_{Ni} represent the thermoelectric coefficients of nickel-chrome and nickel respectively. By adapting the equation according to T_m , the sought-after temperature can be calculated from the voltage measured across the thermocouple. Based on the difference to the cold junction temperature, the temperature at the measurement point can be determined to an accuracy of better than one tenth of a Kelvin with the aid of the above thermocouple equation.

● Sensor circuit

i

A modification of the sensor circuit with additional devices such as change over switches or multiplexer decreases the measure accuracy. We strongly advise against such modifications.

Internal conversion of the thermovoltage and the reference voltage

Since the coefficients are determined at a reference temperature of 0°C, it is necessary to compensate for the effect of the reference temperature. This is done by converting the reference temperature into a reference voltage that depends on the type of thermocouple, and adding this to the measured thermovoltage. The temperature is found from the resulting voltage and the corresponding characteristic curve.

$$U_k = U_m + U_r$$

$$T_{out} = f(U_k)$$

The four LEDs indicate the operating state of the associated terminal channels.

- green Run LEDs: RUN (not applicable for KL3314)
 - On: normal operation
 - Off: Watchdog timer overflow has occurred. If no process data are transmitted by the Bus Coupler for 100 ms, the green LEDs go out.
- Red LEDs: ERROR
 - On: Wire breakage. The resistance is in the invalid range of the characteristic curve of the respective thermocouple.
 - Off: The resistance is in the valid range of the characteristic curve.

Process data output format

In the delivery state, the measured value is displayed in increments of 1/10 °C in two's complement format (integer). Other presentation types can be selected via the feature register (R32) (e.g. signed amount representation, Siemens output format).

Measured value	Output	
	Hexadecimal output	Signed integer output
-200.0 °C	0xF830	-2000
100.0 °C	0xFC18	-1000
0.1 °C	0xFFFF	-1
0.0 °C	0x0000	0
0.1 °C	0x0001	1
100.0 °C	0x03E8	1000
200.0 °C	0x07D0	2000
500.0 °C	0x1388	5000
850.0 °C	0x2134	8500
1,000.0 °C	0x2710	10000

Voltage limits

- $U_k > U_{kmax}$:
Bits 1 and 6 (overrange and error bits) in the status byte are set. The linearization of the characteristic curve is continued with the coefficients of the overrange limit up to the limit stop of the A/D converter or to the maximum value of 0x7FFF.
- $U_k < U_{kmin}$:
Bits 0 and 6 (underrange and error bits) in the status byte are set. The linearization of the characteristic curve is continued with the coefficients of the underrange limit up to the limit stop of the A/D converter or to the minimum value of 0x8000.

For overrange or underrange the red error LED is switched on.

Calculation of process data

The process data that are transferred to the Bus Coupler are calculated using the following equations:

$T_{ref} = A_{00} * X_{ref}$	(1.0)	Voltage value of the cold junction
$U_{ref} = a_1 * T_{ref}^2 + b_1 * T_{ref} + c_1$	(1.1)	
$U_{m1} = A_a * X_m + B_a$	(1.2)	Measured temperature in 1/16°C
$U_k = U_{ref} + U_{m1}$	(1.3)	
$T = a_0 * U_k^2 + b_0 * U_k + c_0$	(1.4)	
$T_{out} = T$	(1.5)	Neither user nor manufacturer scaling is active
$T_h = A_h * T + B_h$	(1.6)	Manufacturer scaling active (factory setting)
$T_{out} = T_h$		
$T_a = A_w * T + B_w$	(1.7)	User scaling active
$T_{out} = T_a$		
$T_h = A_h * T + B_h$	(1.7)	Manufacturer and user scaling active
$T_a = A_w * T + B_w$		
$T_{out} = T_a$		

Key

Name	Name	Register
X_ref	Output value of the A/D converter	
T_ref	Temperature of the cold junction	
U_ref	Voltage value of the cold junction	
X_m	ADC value of the temperature sensor	
U_m1	Voltage value of the temperature sensor	
A_a	Vendor calibration: Gain	R17
B_a	Vendor calibration: Offset	R18
A_h	Manufacturer scaling: Gain	R20
B_h	Manufacturer scaling: Offset	R19
A_w	User scaling: Gain	R34
B_w	User scaling: Offset	R33
U_k	Sum of U_ref and U_m1	
T	Measured temperature in 1/16°C	
T_h	Temperature after vendor scaling (1/10 °C)	
T_a	Temperature after user scaling	
T_out	Process data to PLC	

The equations of the straight line are enabled via register R32

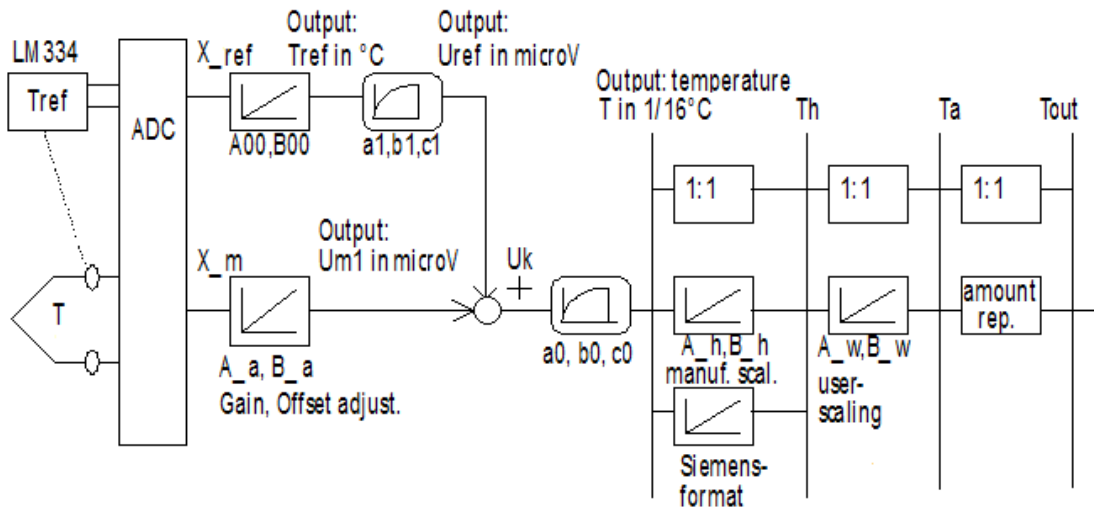

Fig. 3: Data Flow

3 Mounting and wiring

3.1 Instructions for ESD protection

NOTE

Destruction of the devices by electrostatic discharge possible!

The devices contain components at risk from electrostatic discharge caused by improper handling.

- Please ensure you are electrostatically discharged and avoid touching the contacts of the device directly.
- Avoid contact with highly insulating materials (synthetic fibers, plastic film etc.).
- Surroundings (working place, packaging and personnel) should be grounded probably, when handling with the devices.
- Each assembly must be terminated at the right hand end with an [EL9011](#) or [EL9012](#) bus end cap, to ensure the protection class and ESD protection.

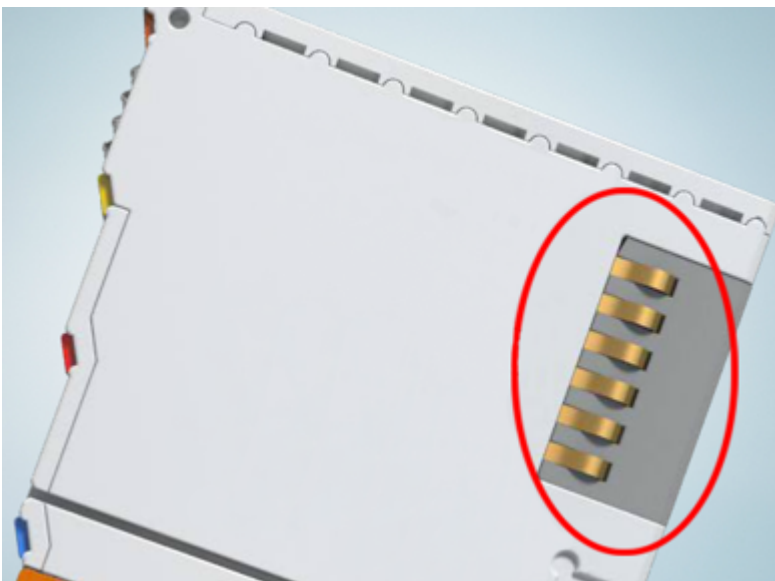

Fig. 4: Spring contacts of the Beckhoff I/O components

3.2 Installation on mounting rails

⚠ WARNING

Risk of electric shock and damage of device!

Bring the bus terminal system into a safe, powered down state before starting installation, disassembly or wiring of the bus terminals!

Assembly

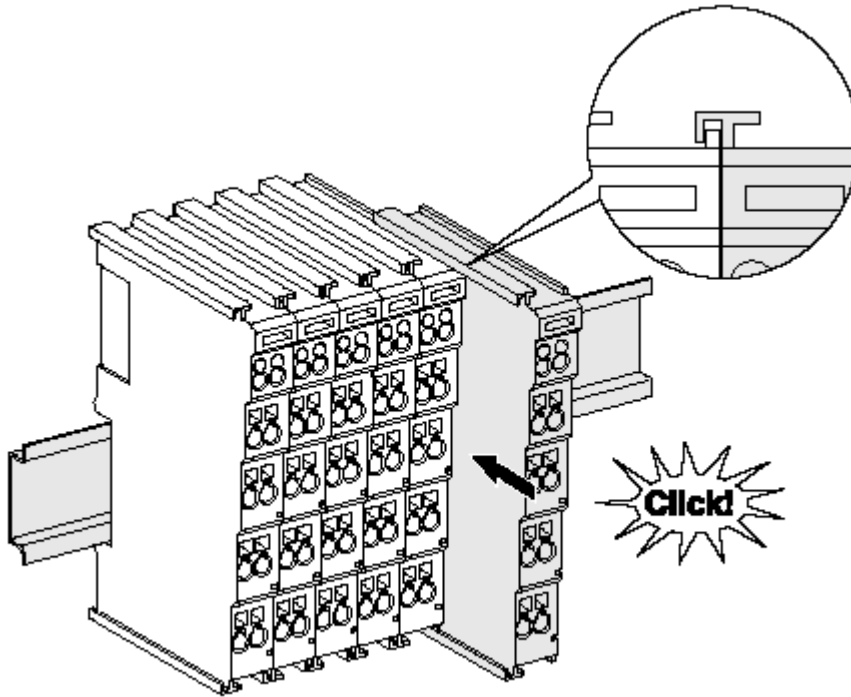

Fig. 5: Attaching on mounting rail

The bus coupler and bus terminals are attached to commercially available 35 mm mounting rails (DIN rails according to EN 60715) by applying slight pressure:

1. First attach the fieldbus coupler to the mounting rail.
2. The bus terminals are now attached on the right-hand side of the fieldbus coupler. Join the components with tongue and groove and push the terminals against the mounting rail, until the lock clicks onto the mounting rail.

If the terminals are clipped onto the mounting rail first and then pushed together without tongue and groove, the connection will not be operational! When correctly assembled, no significant gap should be visible between the housings.

i Fixing of mounting rails

The locking mechanism of the terminals and couplers extends to the profile of the mounting rail. At the installation, the locking mechanism of the components must not come into conflict with the fixing bolts of the mounting rail. To mount the mounting rails with a height of 7.5 mm under the terminals and couplers, you should use flat mounting connections (e.g. countersunk screws or blind rivets).

Disassembly

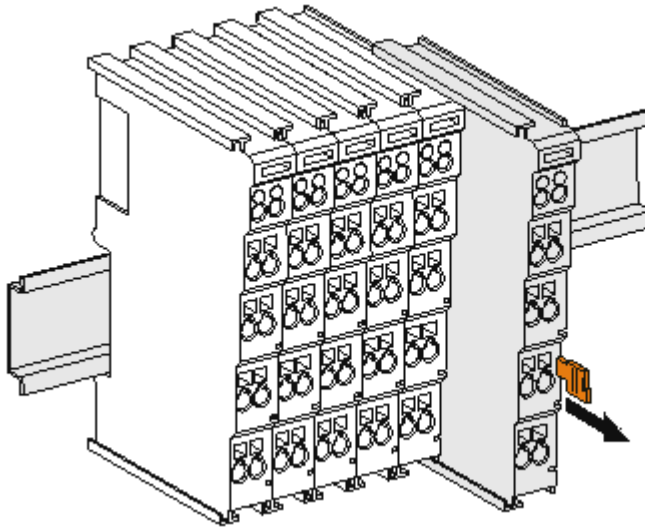

Fig. 6: Disassembling of terminal

Each terminal is secured by a lock on the mounting rail, which must be released for disassembly:

1. Pull the terminal by its orange-colored lugs approximately 1 cm away from the mounting rail. In doing so for this terminal the mounting rail lock is released automatically and you can pull the terminal out of the bus terminal block easily without excessive force.
2. Grasp the released terminal with thumb and index finger simultaneous at the upper and lower grooved housing surfaces and pull the terminal out of the bus terminal block.

Connections within a bus terminal block

The electric connections between the Bus Coupler and the Bus Terminals are automatically realized by joining the components:

- The six spring contacts of the K-Bus/E-Bus deal with the transfer of the data and the supply of the Bus Terminal electronics.
- The power contacts deal with the supply for the field electronics and thus represent a supply rail within the bus terminal block. The power contacts are supplied via terminals on the Bus Coupler (up to 24 V) or for higher voltages via power feed terminals.

● Power Contacts
i

During the design of a bus terminal block, the pin assignment of the individual Bus Terminals must be taken account of, since some types (e.g. analog Bus Terminals or digital 4-channel Bus Terminals) do not or not fully loop through the power contacts. Power Feed Terminals (KL91xx, KL92xx or EL91xx, EL92xx) interrupt the power contacts and thus represent the start of a new supply rail.

PE power contact

The power contact labeled PE can be used as a protective earth. For safety reasons this contact mates first when plugging together, and can ground short-circuit currents of up to 125 A.

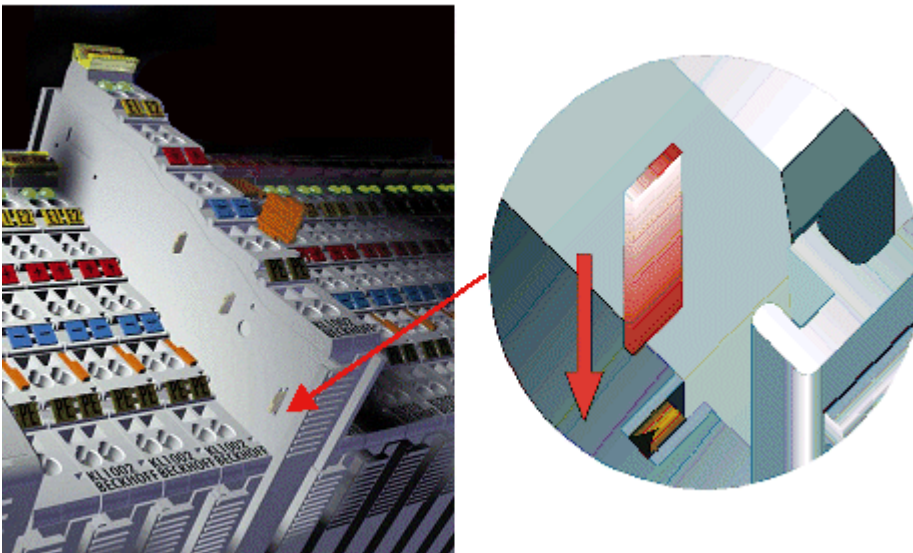

Fig. 7: Power contact on left side

NOTE**Possible damage of the device**

Note that, for reasons of electromagnetic compatibility, the PE contacts are capacitatively coupled to the mounting rail. This may lead to incorrect results during insulation testing or to damage on the terminal (e.g. disruptive discharge to the PE line during insulation testing of a consumer with a nominal voltage of 230 V). For insulation testing, disconnect the PE supply line at the Bus Coupler or the Power Feed Terminal! In order to decouple further feed points for testing, these Power Feed Terminals can be released and pulled at least 10 mm from the group of terminals.

⚠ WARNING**Risk of electric shock!**

The PE power contact must not be used for other potentials!

3.3 Installation instructions for enhanced mechanical load capacity

⚠ WARNING

Risk of injury through electric shock and damage to the device!
 Bring the Bus Terminal system into a safe, de-energized state before starting mounting, disassembly or wiring of the Bus Terminals!

Additional checks

The terminals have undergone the following additional tests:

Verification	Explanation
Vibration	10 frequency runs in 3 axes
	6 Hz < f < 60 Hz displacement 0.35 mm, constant amplitude
	60.1 Hz < f < 500 Hz acceleration 5 g, constant amplitude
Shocks	1000 shocks in each direction, in 3 axes
	25 g, 6 ms

Additional installation instructions

For terminals with enhanced mechanical load capacity, the following additional installation instructions apply:

- The enhanced mechanical load capacity is valid for all permissible installation positions
- Use a mounting rail according to EN 60715 TH35-15
- Fix the terminal segment on both sides of the mounting rail with a mechanical fixture, e.g. an earth terminal or reinforced end clamp
- The maximum total extension of the terminal segment (without coupler) is:
 64 terminals (12 mm mounting with) or 32 terminals (24 mm mounting with)
- Avoid deformation, twisting, crushing and bending of the mounting rail during edging and installation of the rail
- The mounting points of the mounting rail must be set at 5 cm intervals
- Use countersunk head screws to fasten the mounting rail
- The free length between the strain relief and the wire connection should be kept as short as possible. A distance of approx. 10 cm should be maintained to the cable duct.

3.4 Connection

3.4.1 Connection system

⚠ WARNING

Risk of electric shock and damage of device!
 Bring the bus terminal system into a safe, powered down state before starting installation, disassembly or wiring of the bus terminals!

Overview

The Bus Terminal system offers different connection options for optimum adaptation to the respective application:

- The terminals of ELxxxx and KLxxxx series with standard wiring include electronics and connection level in a single enclosure.

- The terminals of ESxxxx and KSxxxx series feature a pluggable connection level and enable steady wiring while replacing.
- The High Density Terminals (HD Terminals) include electronics and connection level in a single enclosure and have advanced packaging density.

Standard wiring (ELxxxx / KLxxxx)



Fig. 8: Standard wiring

The terminals of ELxxxx and KLxxxx series have been tried and tested for years. They feature integrated screwless spring force technology for fast and simple assembly.

Pluggable wiring (ESxxxx / KSxxxx)



Fig. 9: Pluggable wiring

The terminals of ESxxxx and KSxxxx series feature a pluggable connection level. The assembly and wiring procedure is the same as for the ELxxxx and KLxxxx series. The pluggable connection level enables the complete wiring to be removed as a plug connector from the top of the housing for servicing. The lower section can be removed from the terminal block by pulling the unlocking tab. Insert the new component and plug in the connector with the wiring. This reduces the installation time and eliminates the risk of wires being mixed up.

The familiar dimensions of the terminal only had to be changed slightly. The new connector adds about 3 mm. The maximum height of the terminal remains unchanged.

A tab for strain relief of the cable simplifies assembly in many applications and prevents tangling of individual connection wires when the connector is removed.

Conductor cross sections between 0.08 mm² and 2.5 mm² can continue to be used with the proven spring force technology.

The overview and nomenclature of the product names for ESxxxx and KSxxxx series has been retained as known from ELxxxx and KLxxxx series.

High Density Terminals (HD Terminals)



Fig. 10: High Density Terminals

The Bus Terminals from these series with 16 terminal points are distinguished by a particularly compact design, as the packaging density is twice as large as that of the standard 12 mm Bus Terminals. Massive conductors and conductors with a wire end sleeve can be inserted directly into the spring loaded terminal point without tools.

● **Wiring HD Terminals**

i The High Density (HD) Terminals of the ELx8xx and KLx8xx series doesn't support pluggable wiring.

Ultrasonically "bonded" (ultrasonically welded) conductors

● **Ultrasonically "bonded" conductors**

i It is also possible to connect the Standard and High Density Terminals with ultrasonically "bonded" (ultrasonically welded) conductors. In this case, please note the tables concerning the wire-size width below!

3.4.2 Wiring

⚠ WARNING

Risk of electric shock and damage of device!

Bring the bus terminal system into a safe, powered down state before starting installation, disassembly or wiring of the Bus Terminals!

Terminals for standard wiring ELxxxx/KLxxxx and for pluggable wiring ESxxxx/KSxxxx

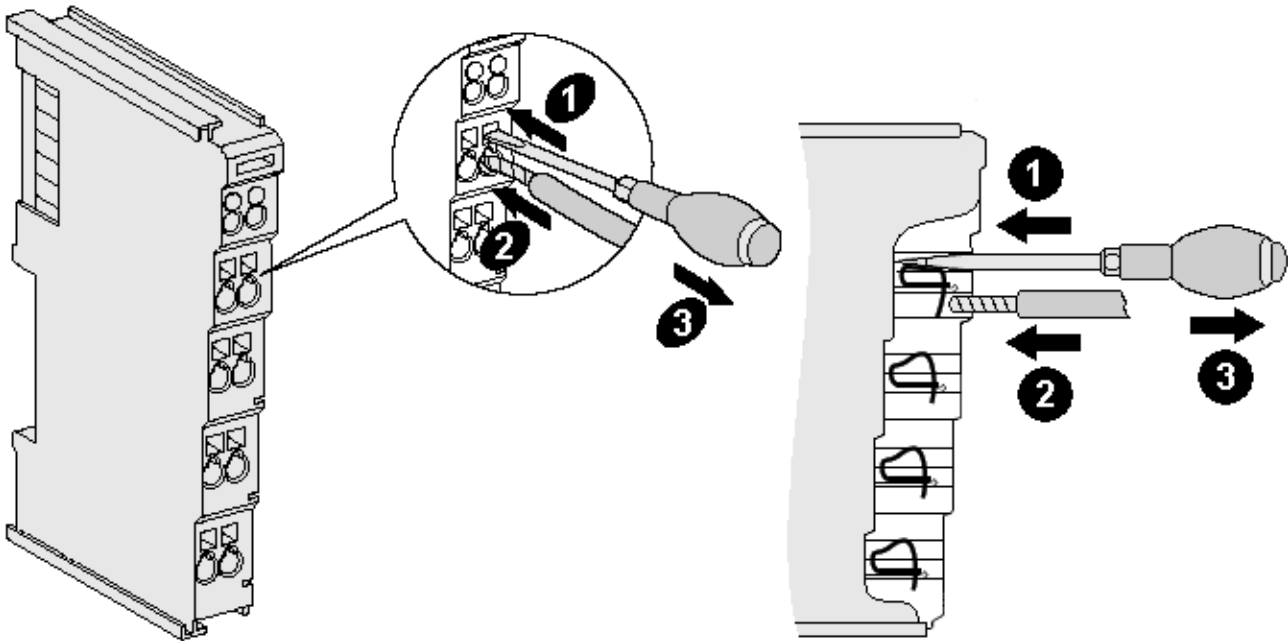

Fig. 11: Connecting a cable on a terminal point

Up to eight terminal points enable the connection of solid or finely stranded cables to the Bus Terminal. The terminal points are implemented in spring force technology. Connect the cables as follows:

1. Open a terminal point by pushing a screwdriver straight against the stop into the square opening above the terminal point. Do not turn the screwdriver or move it alternately (don't toggle).
2. The wire can now be inserted into the round terminal opening without any force.
3. The terminal point closes automatically when the pressure is released, holding the wire securely and permanently.

See the following table for the suitable wire size width.

Terminal housing	ELxxxx, KLxxxx	ESxxxx, KSxxxx
Wire size width (single core wires)	0.08 ... 2.5 mm ²	0.08 ... 2.5 mm ²
Wire size width (fine-wire conductors)	0.08 ... 2.5 mm ²	0,08 ... 2.5 mm ²
Wire size width (conductors with a wire end sleeve)	0.14 ... 1.5 mm ²	0.14 ... 1.5 mm ²
Wire stripping length	8 ... 9 mm	9 ... 10 mm

High Density Terminals (HD Terminals [[▶ 19](#)]) with 16 terminal points

The conductors of the HD Terminals are connected without tools for single-wire conductors using the direct plug-in technique, i.e. after stripping the wire is simply plugged into the terminal point. The cables are released, as usual, using the contact release with the aid of a screwdriver. See the following table for the suitable wire size width.

Terminal housing	High Density Housing
Wire size width (single core wires)	0.08 ... 1.5 mm ²
Wire size width (fine-wire conductors)	0.25 ... 1.5 mm ²
Wire size width (conductors with a wire end sleeve)	0.14 ... 0.75 mm ²
Wire size width (ultrasonically "bonded" conductors)	only 1.5 mm ²
Wire stripping length	8 ... 9 mm

3.4.3 Shielding



Shielding

Encoder, analog sensors and actors should always be connected with shielded, twisted paired wires.

3.5 KL3311 - Connection and LED description

⚠ WARNING

Risk of injury through electric shock and damage to the device!

Bring the Bus Terminals system into a safe, de-energized state before starting mounting, disassembly or wiring of the Bus Terminals!

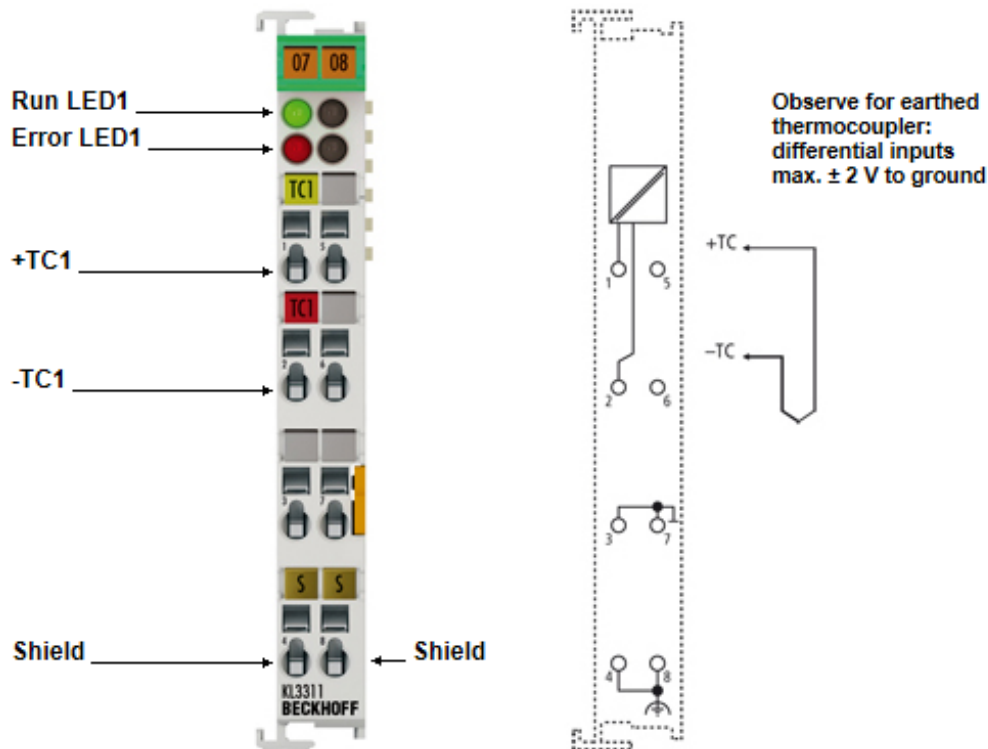

Fig. 12: KL3311 - Connection and LEDs

KL3311 - Connection		
Terminal point	No.	Comment
+TC1	1	Input +TC1
-TC1	2	Input -TC1
GND	3	Ground (internally connected with terminal point 7)
Shield	4	Shield (internally connected to terminal point 8)
n.c.	5	Not used
n.c.	6	Not used
GND	7	Ground (internally connected with terminal point 3)
Shield	8	Shield (internally connected to terminal point 4)

KL3311 - LED Description			
LED	Color	Description	
LED Run1	green	On:	normal operation
		Off:	Watchdog timer overflow has occurred. If no process data is transmitted to the Bus Coupler for 100 ms, the green LEDs go out
Error1 LED	red	on	Wire breakage. The resistance is in the invalid range of the characteristic curve of the respective thermocouple.
		off	The resistance is in the valid range of the characteristic curve

3.6 KL3312, KL3302 - Connection and LED Description

⚠ WARNING

Risk of injury through electric shock and damage to the device!

Bring the Bus Terminals system into a safe, de-energized state before starting mounting, disassembly or wiring of the Bus Terminals!

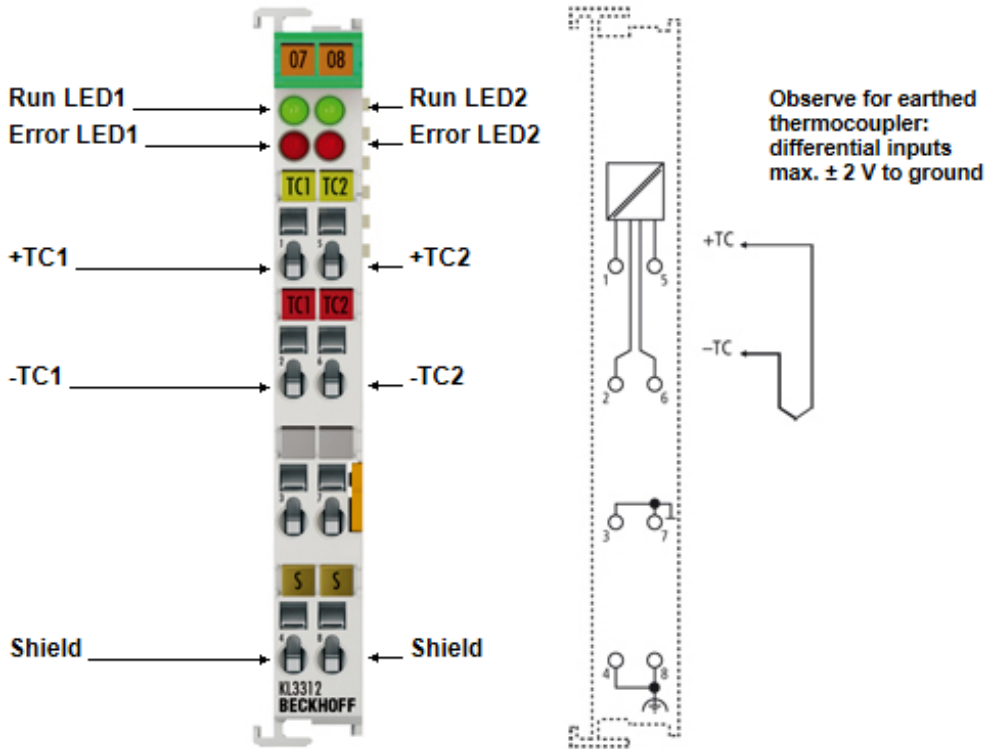

Fig. 13: KL3312, KL3302 - Connection and LEDs

KL3302 is no longer available and was replaced with KL3312.

KL3312 - Connection		
Terminal point	No.	Comment
+TC1	1	Input +TC1
-TC1	2	Input -TC1
GND	3	Ground (internally connected with terminal point 7)
Shield	4	Shield (internally connected to terminal point 8)
+TC2	5	Input +TC2
-TC2	6	Input -TC2
GND	7	Ground (internally connected with terminal point 3)
Shield	8	Shield (internally connected to terminal point 4)

KL3312 - LED Description			
LED	Color	Description	
Run1 LED, Run2 LED	green	On:	Normal operation
		Off:	Watchdog timer overflow has occurred. If no process data is transmitted to the Bus Coupler for 100 ms, the green LEDs go out
Error1 LED Error2 LED	red	On	Wire breakage. The resistance is in the invalid range of the characteristic curve of the respective thermocouple.
		Off	The resistance is in the valid range of the characteristic curve

3.7 KL3314 - Connection and LED description

⚠ WARNING

Risk of injury through electric shock and damage to the device!

Bring the Bus Terminals system into a safe, de-energized state before starting mounting, disassembly or wiring of the Bus Terminals!

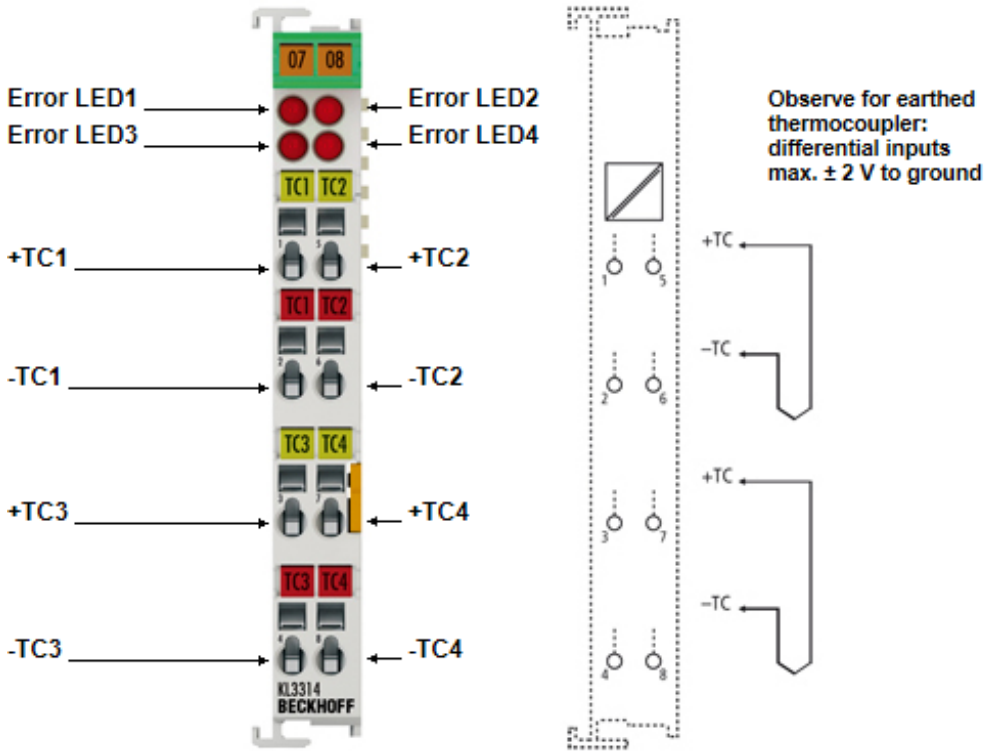

Fig. 14: KL3314 - Connection and LEDs

KL3314 - Connection		
Terminal point	No.	Comment
+TC1	1	Input +TC1
-TC1	2	Input -TC1
+TC3	3	Input +TC3
-TC3	4	Input -TC3
+TC2	5	Input +TC2
-TC2	6	Input -TC2
+TC4	7	Input +TC4
-TC4	8	Input -TC4

KL3314 - LED Description		
LED	Color	Description
Error1 LED, Error2 LED, Error3 LED, Error4 LED	red	On Wire breakage. The resistance is in the invalid range of the characteristic curve of the respective thermocouple.
		Off The resistance is in the valid range of the characteristic curve

3.8 Connection of ground, shield und earthing

Due to the differential inputs of the terminals, different methods for connection of ground, shield und earthing are recommended depending on the type of thermocouple used.

- For earthed thermocouples, ground is connected to the shield.
- If the thermocouple has no earth connection, the ground, shield and -TC1 or -TC2 contacts are connected with each other.

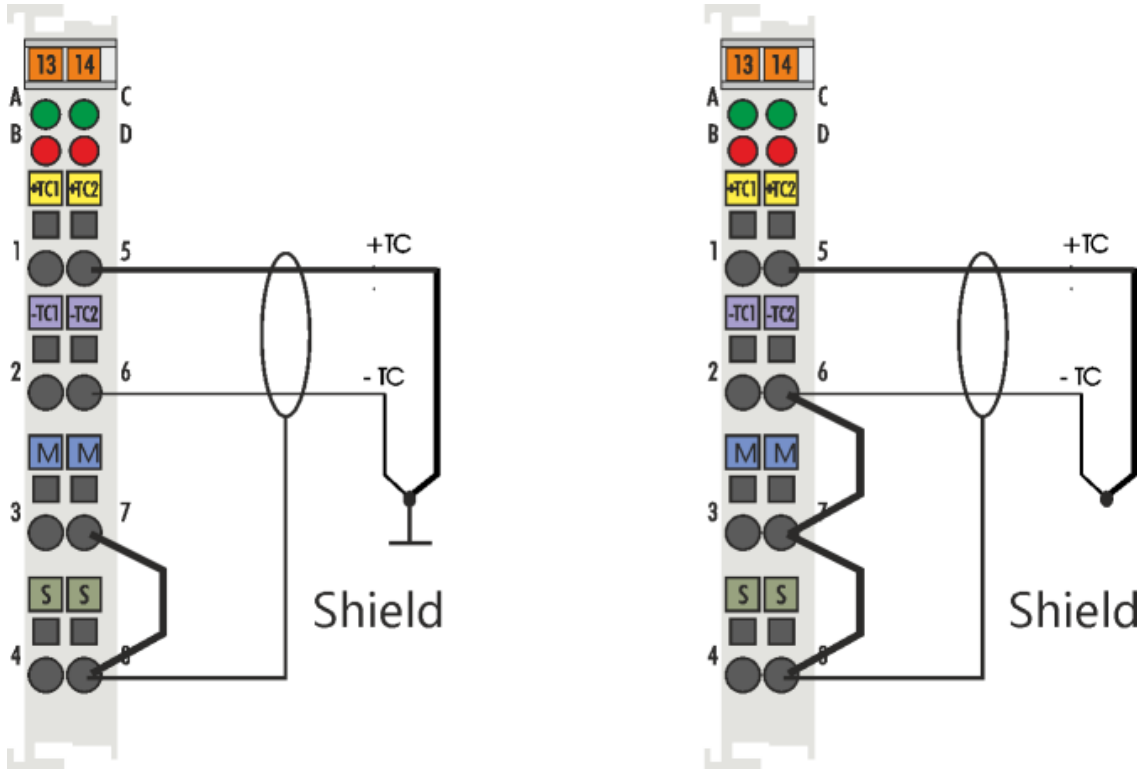

Fig. 15: KL3312 - Connection of ground, shield und earthing (left: earthed thermocouple, right: non-earthed thermocouple)

The examples show the situation for KL3312. For the KL3314, the shield should be connected to an additional shield terminal (KL9195).

3.9 ATEX - Special conditions (standard temperature range)

⚠ WARNING

Observe the special conditions for the intended use of Beckhoff fieldbus components with standard temperature range in potentially explosive areas (directive 94/9/EU)!

- The certified components are to be installed in a suitable housing that guarantees a protection class of at least IP54 in accordance with EN 60529! The environmental conditions during use are thereby to be taken into account!
- If the temperatures during rated operation are higher than 70°C at the feed-in points of cables, lines or pipes, or higher than 80°C at the wire branching points, then cables must be selected whose temperature data correspond to the actual measured temperature values!
- Observe the permissible ambient temperature range of 0 to 55°C for the use of Beckhoff fieldbus components standard temperature range in potentially explosive areas!
- Measures must be taken to protect against the rated operating voltage being exceeded by more than 40% due to short-term interference voltages!
- The individual terminals may only be unplugged or removed from the Bus Terminal system if the supply voltage has been switched off or if a non-explosive atmosphere is ensured!
- The connections of the certified components may only be connected or disconnected if the supply voltage has been switched off or if a non-explosive atmosphere is ensured!
- The fuses of the KL92xx/EL92xx power feed terminals may only be exchanged if the supply voltage has been switched off or if a non-explosive atmosphere is ensured!
- Address selectors and ID switches may only be adjusted if the supply voltage has been switched off or if a non-explosive atmosphere is ensured!

Standards

The fundamental health and safety requirements are fulfilled by compliance with the following standards:

- EN 60079-0:2012+A11:2013
- EN 60079-15:2010

Marking

The Beckhoff fieldbus components with standard temperature range certified for potentially explosive areas bear one of the following markings:



II 3G KEMA 10ATEX0075 X Ex nA IIC T4 Gc Ta: 0 ... 55°C

or



II 3G KEMA 10ATEX0075 X Ex nC IIC T4 Gc Ta: 0 ... 55°C

3.10 ATEX Documentation

i Notes about operation of the Beckhoff terminal systems in potentially explosive areas (ATEX)

Pay also attention to the continuative documentation

Notes about operation of the Beckhoff terminal systems in potentially explosive areas (ATEX)

that is available in the download area of the Beckhoff homepage <http://www.beckhoff.com!>

4 KS2000 Configuration Software

4.1 KS2000 - Introduction

The KS2000 configuration software permits configuration, commissioning and parameterization of bus couplers, of the affiliated bus terminals and of Fieldbus Box Modules. The connection between bus coupler / Fieldbus Box Module and the PC is established by means of the serial configuration cable or the fieldbus.



Fig. 16: KS2000 configuration software

Configuration

You can configure the Fieldbus stations with the Configuration Software KS2000 offline. That means, setting up a terminal station with all settings on the couplers and terminals resp. the Fieldbus Box Modules can be prepared before the commissioning phase. Later on, this configuration can be transferred to the terminal station in the commissioning phase by means of a download. For documentation purposes, you are provided with the breakdown of the terminal station, a parts list of modules used and a list of the parameters you have modified. After an upload, existing fieldbus stations are at your disposal for further editing.

Parameterization

KS2000 offers simple access to the parameters of a fieldbus station: specific high-level dialogs are available for all bus couplers, all intelligent bus terminals and Fieldbus Box modules with the aid of which settings can be modified easily. Alternatively, you have full access to all internal registers of the bus couplers and intelligent terminals. Refer to the register description for the meanings of the registers.

Commissioning

The KS2000 software facilitates commissioning of machine components or their fieldbus stations: Configured settings can be transferred to the fieldbus modules by means of a download. After a *login* to the terminal station, it is possible to define settings in couplers, terminals and Fieldbus Box modules directly *online*. The same high-level dialogs and register access are available for this purpose as in the configuration phase.

The KS2000 offers access to the process images of the bus couplers and Fieldbus Box modules.

- Thus, the coupler's input and output images can be observed by monitoring.
- Process values can be specified in the output image for commissioning of the output modules.

All possibilities in the *online mode* can be used in parallel with the actual fieldbus mode of the terminal station. The fieldbus protocol always has the higher priority in this case.

4.2 Sample program for KL register communication via EtherCAT on KL3314 exemplary

● Using the sample programs



This document contains sample applications of our products for certain areas of application. The application notes provided here are based on typical features of our products and only serve as examples. The notes contained in this document explicitly do not refer to specific applications. The customer is therefore responsible for assessing and deciding whether the product is suitable for a particular application. We accept no responsibility for the completeness and correctness of the source code contained in this document. We reserve the right to modify the content of this document at any time and accept no responsibility for errors and missing information.

Program description / function

This example program (TwinCAT 3) provides change of single register values of the KL3314 as selection of the element type, characteristic settings of the feature register R32 and user scaling offset and gain (R33/R34) similar as per KS2000.

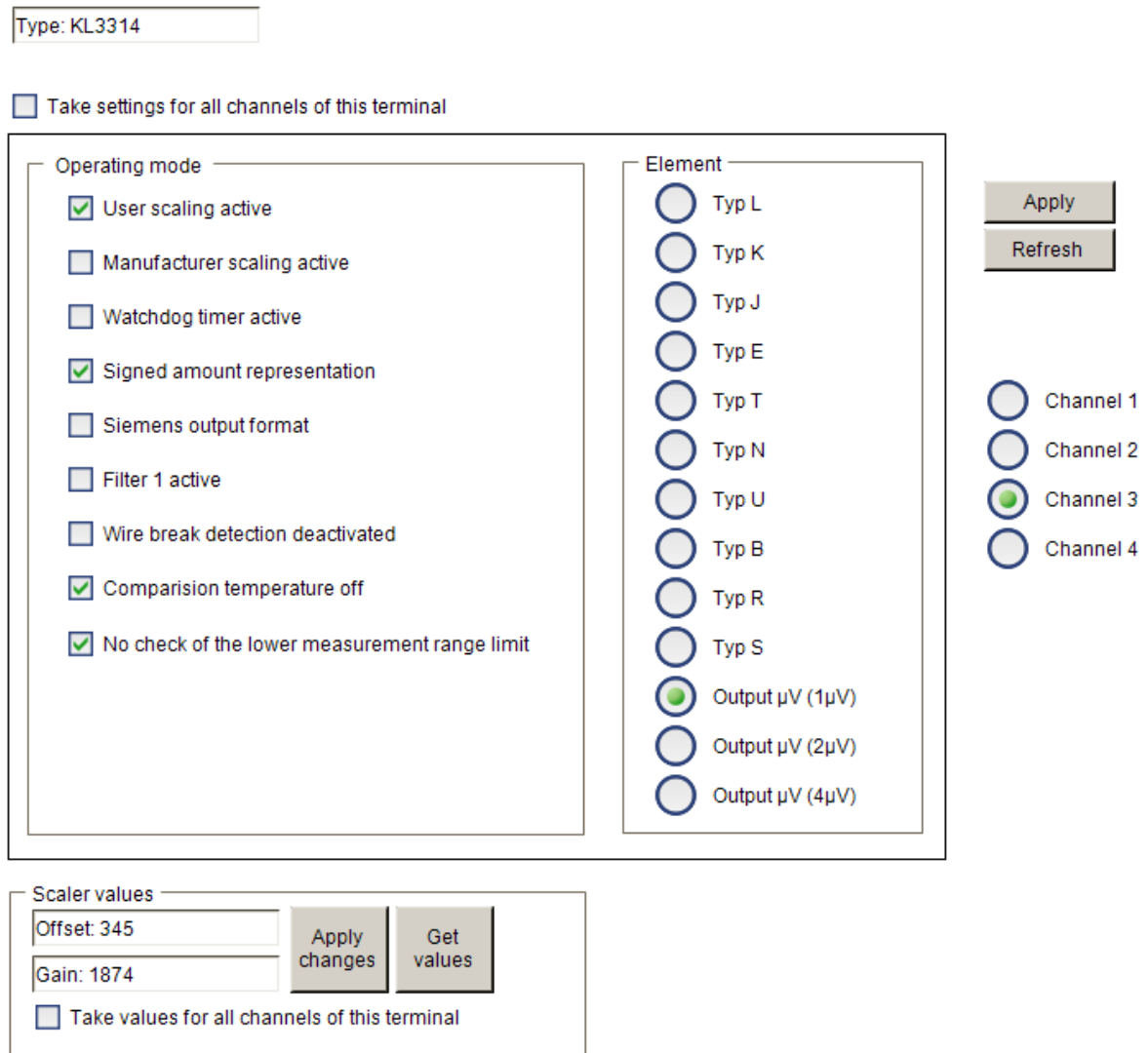

Fig. 17: Settings of KL3314 via visualisation of TwinCAT 3

At least following configuration setup shall be present:

[coupler (e.g. BK1120) or embedded PC] + KL3314 + KL9010.

 Download:
https://infosys.beckhoff.com/content/1033/kl331x_kl3302/Resources/zip/5996114571.zip

Preparations for starting the sample programs (tnzip file / TwinCAT 3)

- Click on the download button to save the Zip archive locally on your hard disk, then unzip the *.tnzip archive file in a temporary folder.

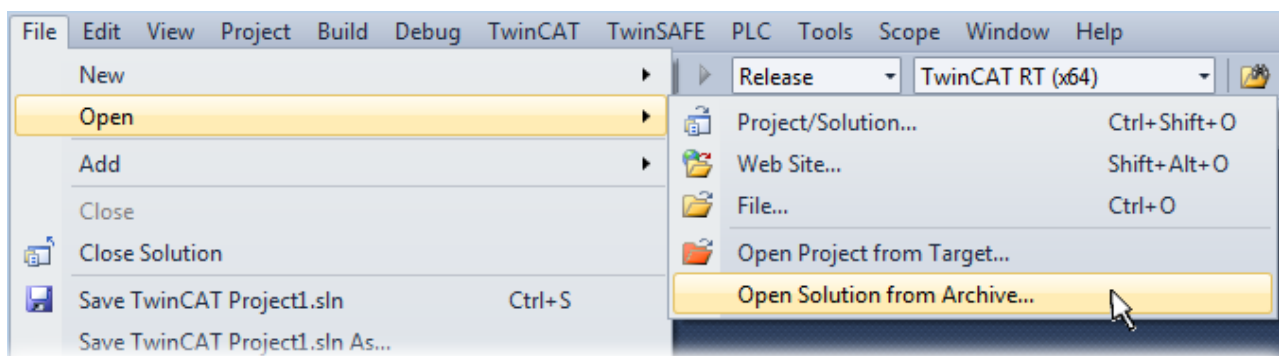

Fig. 18: Opening the *.tnzip archive

- Select the .tnzip file (sample program).
- A further selection window opens. Select the destination directory for storing the project.
- For a description of the general PLC commissioning procedure and starting the program please refer to the terminal documentation or the EtherCAT system documentation.
- The EtherCAT device of the example should usually be declared your present system. After selection of the EtherCAT device in the “Solutionexplorer” select the “Adapter” tab and click on “Search...”:

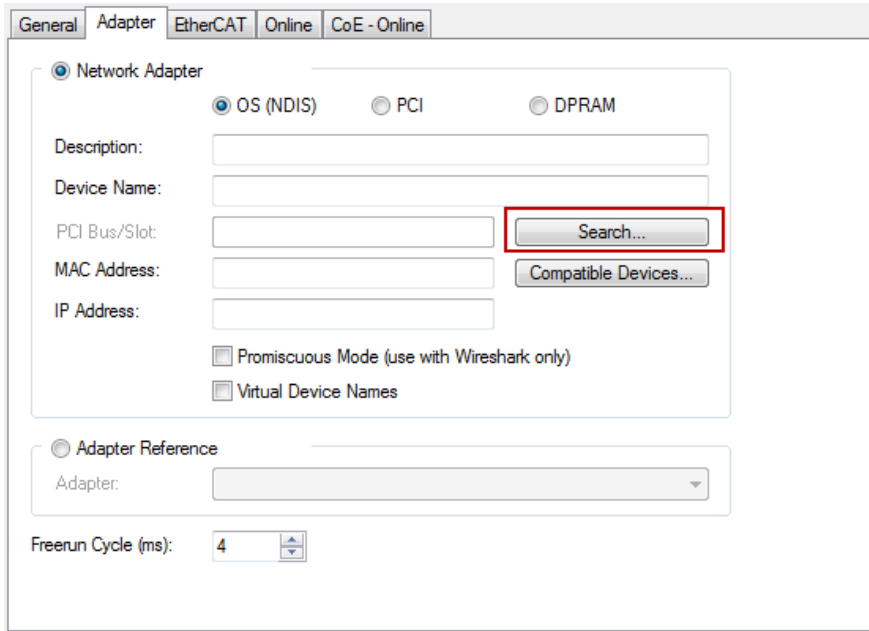
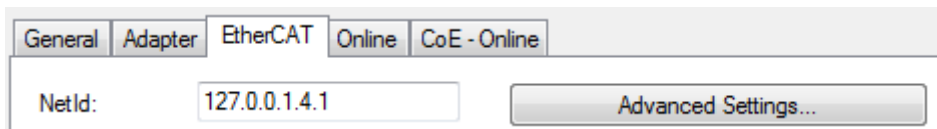

Fig. 19: Search of the existing HW configuration for the EtherCAT configuration of the example

- Checking NetId: the "EtherCAT" tab of the EtherCAT device shows the configured NetId:



The first 4 numbers have to be identical with the project NetId of the target system. The project NetId can be viewed within the TwinCAT environment above, where a pull down menu can be opened to choose a target system (by clicking right in the text field). The number blocks are placed in brackets there next to each computer name of a target system.

- Modify the NetId: By right clicking on "EtherCAT device" within the solution explorer a context menu opens where "Change NetId..." have to be selected. The first 4 numbers of the NetId of the target computer have to be entered; the both last values are 4.1 usually.
Example:

- NetId of project: myComputer (123.45.67.89.1.1)
- Entry via „Change NetId...“: 123.45.67.89.4.1

5 Access from the user program

5.1 KL331x, KL3302 - Terminal Configuration

The terminal can be configured and parameterized via the internal register structure. Each terminal channel is mapped in the Bus Coupler. Mapping of the terminal data in the Bus Coupler memory may differ, depending on the Bus Coupler type and the set mapping configuration (e.g. Motorola/Intel format, word alignment etc.). For parameterizing a terminal, the control and status byte also has to be mapped.

BK2000 Lightbus Coupler

In the BK2000 Lightbus Coupler, the control/status byte is always mapped, in addition to the data bytes. This is always located in the low byte at the offset address of the terminal channel.

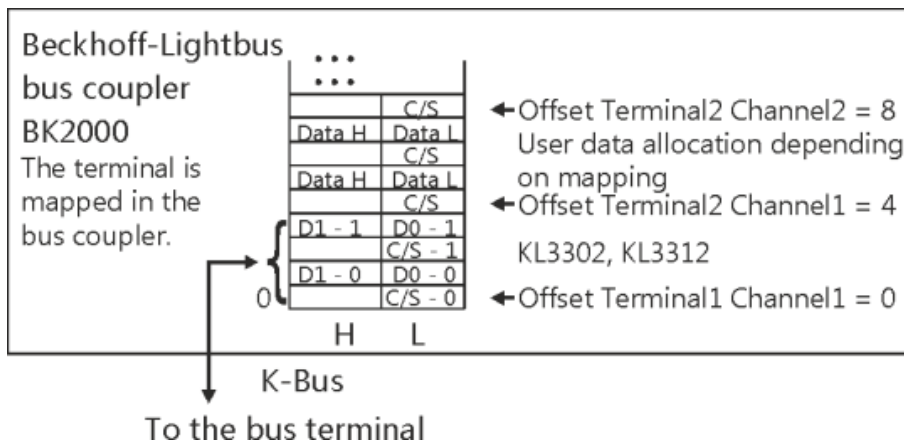

Fig. 20: Mapping in the Lightbus Coupler - example for KL3312, KL3302

BK3000 Profibus Coupler

For the BK3000 Profibus Coupler, the master configuration should specify for which terminal channels the control and status byte is to be inserted. If the control and status byte are not evaluated, the terminals occupy 2 bytes per channel:

- KL3311: 2 bytes of input data
- KL3312 (KL3302): 4 bytes of input data
- KL3314: 8 bytes of input data

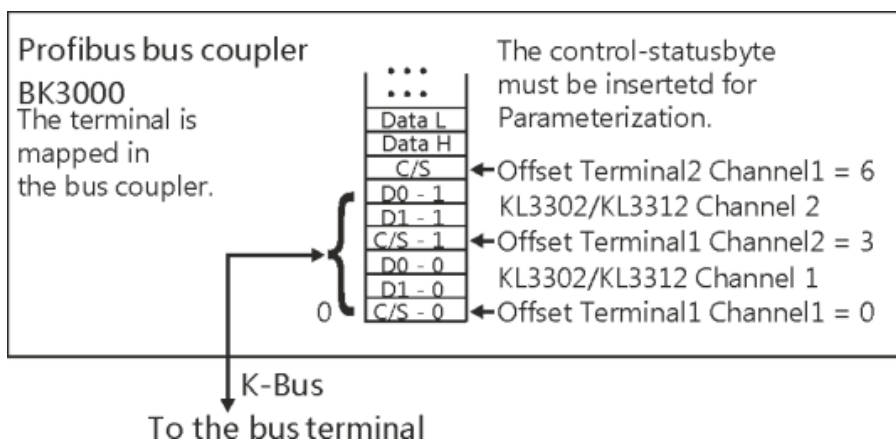

Fig. 21: Mapping in the Profibus Coupler - example for KL3312, KL3302

BK4000 Interbus Coupler

The BK4000 Interbus Coupler maps the terminals in the delivery state with 2 bytes per channel:

- KL3311: 2 bytes of input data
- KL3312 (KL3302): 4 bytes of input data
- KL3314: 8 bytes of input data

Parameterization via the fieldbus is not possible. If the control and status byte is to be used, the KS2000 configuration software is required.

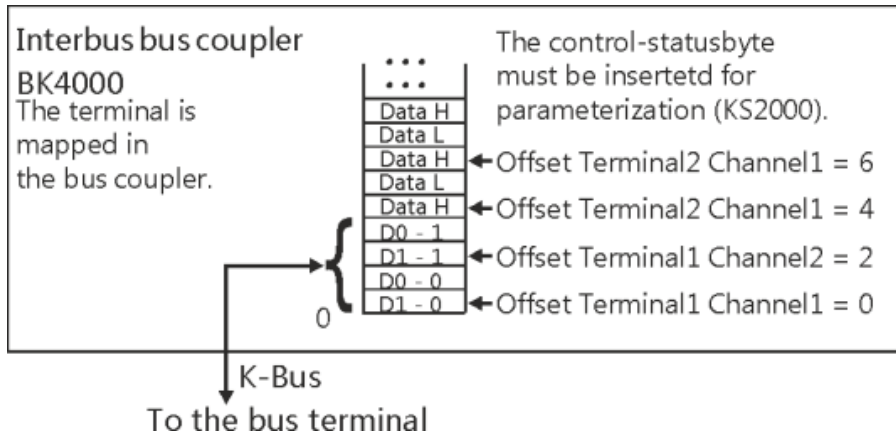

Fig. 22: Mapping in the Interbus Coupler - example for KL3312, KL3302

Other Bus Couplers and further information

Further information about the mapping configuration of Bus Couplers can be found in the Appendix of the respective Bus Coupler manual under *Master configuration*.

The chapter on Mapping in the Bus Coupler contains an overview of possible mapping configurations, depending on the configurable parameters.

● Parameterization with KS2000



The KS2000 configuration software can be used for parameterizations via the serial interface of the Bus Coupler, independent of the fieldbus system.

5.2 Mapping in the Bus Coupler

As already described in the *Terminal Configuration* section, each Bus Terminal is mapped in the Bus Coupler. This mapping is usually done with the default setting in the Bus Coupler / Bus Terminal. The KS2000 configuration software or a master configuration software (e.g. ComProfibus or TwinCAT System Manager) can be used to change this default setting.

If the terminals are fully evaluated, they occupy memory space in the input and output process image. The following tables provide information about how the terminals map themselves in the Bus Coupler, depending on the parameters set.

5.2.1 KL3311 - Default Mapping

For: CANopen, CANCEL, DeviceNet, ControlNet, Modbus, RS232 and RS485 Coupler

Conditions	Word offset	High byte	Low byte
Complete evaluation: no Motorola format: no Word alignment: any	0	Ch0 D1	Ch0 D0
	1	-	-
	2	-	-
	3	-	-

For: Profibus and Interbus Coupler

Conditions	Word offset	High byte	Low byte
Complete evaluation: no Motorola format: yes Word alignment: any	0	Ch0 D0	Ch0 D1
	1	-	-
	2	-	-
	3	-	-

Conditions	Word offset	High byte	Low byte
Complete evaluation: yes Motorola format: no Word alignment: no	0	Ch0 D0	Ch0 CB/SB
	1	-	Ch0 D0
	2	-	-
	3	-	-

Conditions	Word offset	High byte	Low byte
Complete evaluation: yes Motorola format: yes Word alignment: no	0	Ch0 D1	Ch0 CB/SB
	1	-	Ch0 D0
	2	-	-
	3	-	-

For: Lightbus & Ethernet Coupler and Bus Terminal Controller (BCxxxx, BXxxxx)

Conditions	Word offset	High byte	Low byte
Complete evaluation: yes Motorola format: no Word alignment: yes	0	Res.	Ch0 CB/SB
	1	Ch0 D1	Ch0 D0
	2	-	-
	3	-	-

Conditions	Word offset	High byte	Low byte
Complete evaluation: yes Motorola format: yes Word alignment: yes	0	Res.	Ch0 CB/SB
	1	Ch0 D0	Ch0 D1
	2	-	-
	3	-	-

Key

Complete evaluation	The terminal is mapped with control and status byte.
Motorola format	Motorola or Intel format can be set.
Word alignment	The terminal is positioned on a word boundary in the Bus Coupler.
Ch n CB	Control byte for channel n (appears in the process image of the outputs).
Ch n SB	Status byte for channel n (appears in the process image of the inputs).
Ch n D0	Channel n, data byte 0 (byte with the lowest value)
Ch n D1	Channel n, data byte 1 (byte with the highest value)
"_"	This byte is not used or occupied by the terminal.
Res.	Reserved: this byte is assigned to the process data memory, although it has no function.

5.2.2 KL3312 (KL3302) - Default Mapping

For: CANopen, CANCEL, DeviceNet, ControlNet, Modbus, RS232 and RS485 Coupler

Conditions	Word offset	High byte	Low byte
Complete evaluation: no Motorola format: no Word alignment: any	0	Ch0 D1	C0 D0
	1	Ch1 D1	Ch1 D0
	2	-	-
	3	-	-

For: Profibus and Interbus Coupler

Conditions	Word offset	High byte	Low byte
Complete evaluation: no Motorola format: yes Word alignment: any	0	Ch0 D0	Ch0 D1
	1	Ch1 D0	Ch1 D1
	2	-	-
	3	-	-

Conditions	Word offset	High byte	Low byte
Complete evaluation: yes Motorola format: no Word alignment: no	0	Ch0 D0	Ch0 CB/SB
	1	Ch1 CB/SB	Ch0 D1
	2	Ch1 D1	Ch1 D0
	3	-	-

Conditions	Word offset	High byte	Low byte
Complete evaluation: yes Motorola format: yes Word alignment: no	0	Ch0 D1	Ch0 CB/SB
	1	Ch1 CB/SB	Ch0 D0
	2	Ch1 D0	Ch1 D1
	3	-	-

For: Lightbus & Ethernet Coupler and Bus Terminal Controller (BCxxxx, BXxxxx)

Conditions	Word offset	High byte	Low byte
Complete evaluation: yes Motorola format: no Word alignment: yes	0	Res.	Ch0 CB/SB
	1	Ch0 D1	Ch0 D0
	2	Res.	Ch1 CB/SB
	3	Ch1 D1	Ch1 D0

Conditions	Word offset	High byte	Low byte
Complete evaluation: yes Motorola format: yes Word alignment: yes	0	Res.	Ch0 CB/SB
	1	Ch0 D0	Ch0 D1
	2	Res.	Ch1 CB/SB
	3	Ch1 D0	Ch1 D1

Key

Complete evaluation	The terminal is mapped with control and status byte.
Motorola format	Motorola or Intel format can be set.
Word alignment	The terminal is positioned on a word boundary in the Bus Coupler.
Ch n CB	Control byte for channel n (appears in the process image of the outputs).
Ch n SB	Status byte for channel n (appears in the process image of the inputs).
Ch n D0	Channel n, data byte 0 (byte with the lowest value)
Ch n D1	Channel n, data byte 1 (byte with the highest value)
"_"	This byte is not used or occupied by the terminal.
Res.	Reserved: this byte is assigned to the process data memory, although it has no function.

5.2.3 KL3314 - Default Mapping

For: CANopen, CANCEL, DeviceNet, ControlNet, Modbus, RS232 and RS485 Coupler

Conditions	Word offset	High byte	Low byte
Complete evaluation: no Motorola format: no Word alignment: any	0	Ch0 D1	Ch0 D0
	1	Ch1 D1	Ch1 D0
	2	Ch2 D1	Ch2 D0
	3	Ch3 D1	Ch3 D0

For: Profibus and Interbus Coupler

Conditions	Word offset	High byte	Low byte
Complete evaluation: no Motorola format: yes Word alignment: any	0	Ch0 D0	Ch0 D1
	1	Ch1 D0	Ch1 D1
	2	Ch2 D0	Ch2 D1
	3	Ch3 D0	Ch3 D1

Conditions	Word offset	High byte	Low byte
Complete evaluation: yes Motorola format: no Word alignment: no	0	Ch0 D0	Ch0 CB/SB
	1	Ch1 CB/SB	Ch0 D1
	2	Ch1 D1	Ch1 D0
	3	Ch2 D0	Ch2 CB/SB
	4	Ch3 CB/SB	Ch2 D1
	5	Ch3 D1	Ch3 D0

Conditions	Word offset	High byte	Low byte
Complete evaluation: yes Motorola format: yes Word alignment: no	0	Ch0 D1	Ch0 CB/SB
	1	Ch1 CB/SB	Ch0 D0
	2	Ch1 D0	Ch1 D1
	3	Ch2 D1	Ch2 CB/SB
	4	Ch3 CB/SB	Ch2 D0
	5	Ch3 D0	Ch3 D1

For: Lightbus & Ethernet Coupler and Bus Terminal Controller (BCxxxx, BXxxxx)

Conditions	Word offset	High byte	Low byte
Complete evaluation: yes Motorola format: no Word alignment: yes	0	Res.	Ch0 CB/SB
	1	Ch0 D1	Ch0 D0
	2	Res.	Ch1 CB/SB
	3	Ch1 D1	Ch1 D0
	4	Res.	Ch2 CB/SB
	5	Ch2 D1	Ch2 D0
	6	Res.	Ch3 CB/SB
	7	Ch3 D1	Ch3 D0

Conditions	Word offset	High byte	Low byte
Complete evaluation: yes Motorola format: yes Word alignment: yes	0	Res.	Ch0 CB/SB
	1	Ch0 D0	Ch0 D1
	2	Res.	Ch1 CB/SB
	3	Ch1 D0	Ch1 D1
	4	Res.	Ch2 CB/SB
	5	Ch2 D0	Ch2 D1
	6	Res.	Ch3 CB/SB
	7	Ch3 D0	Ch3 D1

Key

Complete evaluation	The terminal is mapped with control and status byte.
Motorola format	Motorola or Intel format can be set.
Word alignment	The terminal is positioned on a word boundary in the Bus Coupler.
Ch n CB	Control byte for channel n (appears in the process image of the outputs).
Ch n SB	Status byte for channel n (appears in the process image of the inputs).
Ch n D0	Channel n, data byte 0 (byte with the lowest value)
Ch n D1	Channel n, data byte 1 (byte with the highest value)
Res.	Reserved: this byte is assigned to the process data memory, although it has no function.

5.3 Register overview

These registers exist once for each channel

Address	Name	Default value	R/W	Storage medium
R0 [▶ 38]	Raw ADC value	variable	R	RAM
R1...R5	reserved	0x0000	R	
R6 [▶ 38]	Diagnostic register	variable	R	RAM
R7 [▶ 38]	Command register - not used	0x0000	R	
R8 [▶ 38]	Terminal type	e.g. 3312	R	ROM
R9 [▶ 38]	Software version number	0x????	R	ROM
R10 [▶ 38]	Multiplex shift register	0x0218/0130	R	ROM
R11 [▶ 38]	Signal channels	0x0218	R	ROM
R12 [▶ 38]	Minimum data length	0x0098	R	ROM
R13 [▶ 38]	Data structure	0x0000	R	ROM
R14	reserved	0x0000	R	
R15 [▶ 39]	Alignment register	variable	R/W	RAM
R16 [▶ 39]	Hardware version number	0x????	R/W	SEEPROM
R17 [▶ 39]	Hardware compensation: Offset	specific	R/W	SEEPROM
R18 [▶ 39]	Hardware compensation: Gain	specific	R/W	SEEPROM
R19 [▶ 39]	Manufacturer scaling: Offset	0x0000	R/W	SEEPROM
R20 [▶ 39]	Manufacturer scaling: Gain	0x00A0	R/W	SEEPROM
R21 [▶ 39]	Hardware compensation: Reference temperature	specific	R/W	SEEPROM
R22...R30	reserved	0x0000	R/W	SEEPROM
R31 [▶ 39]	Code word register	variable	R/W	RAM
R32 [▶ 40]	Feature register	0x01006	R/W	SEEPROM
R33 [▶ 40]	User scaling: Offset	0x0000	R/W	SEEPROM
R34 [▶ 41]	User scaling: Gain	0x0100	R/W	SEEPROM
R35...R63	reserved	0x0000	R/W	SEEPROM

5.4 Register description

The registers can be read or written via the register communication. They are used for the parameterization of the terminal.

R0 to R7: Registers in the internal RAM of the terminal

The process variables can be used in addition to the actual process image. Their function is specific to the terminal.

- **R0 ADC raw value (X_m)**
This register contains the ADC raw value of the connected element according to (equation 1.2) (where 0x0000 is approximately equal to -125 mV, 0x8000 approx. 0 V and 0xFFFF approx. 125 mV; this means that gain and offset errors are included).
- **R1 to R5: Reserved**
- **R6: Diagnostic register**
 - High byte: reserved
 - Low byte: Status byte
- **R7: Command register**
High-Byte_Write = function parameter
Low-Byte_Write = function number
High-Byte_Read = function result
Low-Byte_Read = function number

R8 to R15: Registers in the internal ROM of the terminal

The type and system parameters are hard programmed by the manufacturer, and the user can read them but cannot change them.

- **R8: Terminal type**
The terminal type in register R8 is needed to identify the terminal.
- **R9: Software version (X.y)**
The software version can be read as a string of ASCII characters.
- **R10: Data length**
R10 contains the number of multiplexed shift registers and their length in bits.
The Bus Coupler sees this structure.
- **R11: Signal channels**
Related to R10, this contains the number of channels that are logically present. Thus for example a shift register that is physically present can perfectly well consist of several signal channels.
- **R12: Minimum data length**
The particular byte contains the minimum data length for a channel that is to be transferred. If the MSB is set, the control and status byte is not necessarily required for the terminal function and is not transferred to the control, if the Bus Coupler is configured accordingly.
- **R13: Data type register**

Data type register	Meaning
0x00	Terminal with no valid data type
0x01	Byte array
0x02	Structure 1 byte n bytes
0x03	Word array
0x04	Structure 1 byte n words
0x05	Double word array
0x06	Structure 1 byte n double words
0x07	Structure 1 byte 1 double word
0x08	Structure 1 byte 1 double word
0x11	Byte array with variable logical channel length
0x12	Structure 1 byte n bytes with variable logical channel length (e.g. 60xx)
0x13	Word array with variable logical channel length
0x14	Structure 1 byte n words with variable logical channel length
0x15	Double word array with variable logical channel length
0x16	Structure 1 byte n double words with variable logical channel length

- **R14: reserved**

- **R15: Alignment bits (RAM)**

The alignment bits are used to place the analog terminal in the Bus Coupler on a byte boundary.

R16 to R30: Manufacturer parameter area (SEEROM)

The manufacturer parameters are specific for each type of terminal. They are programmed by the manufacturer, but can also be modified by the controller. The manufacturer parameters are stored in a serial EEPROM in the terminal, and are retained in the event of voltage drop-out.

These registers can only be altered after a code word has been set in R31 [► 39].

- **R17: Hardware compensation - offset (B_a)**

16-bit signed integer

This register is used for offset compensation of the terminal (Eq. 1.2 [► 12]).

Register value approx. 0x0000

- **R18: Hardware compensation - gain (A_a)**

16 bit signed integer*2⁻¹²

This register is used for gain compensation of the terminal (Eq. 1.2 [► 12]).

Register value approx. 0x3D4X

- **R19: Manufacturer scaling - offset (B_h)**

16-bit signed integer [0x0000]

This register contains the offset of the manufacturer linear equation (equation 1.6 [► 12]). The linear equation is enabled via register R32.

- **R20: Manufacturer scaling - gain (A_h)**

16 bit signed integer*2⁻⁸ [0x00A0]

This register contains the scale factor of the manufacturer's equation of the straight line (Eq. 1.6 [► 12]).

The linear equation is enabled via register R32.

- **R21: Manufacturer gain compensation for reference voltage**

[approx. 0x01XX]

R31 to R47: User parameter area (SEEROM)

The user parameters are specific for each type of terminal. They can be modified by the programmer. The user parameters are stored in a serial EEPROM in the terminal, and are retained in the event of voltage drop-out. The user area is write-protected by a code word.

- **R31: Code word register in RAM**

i The code word **0x1235** must be entered here so that parameters in the user area can be modified. If any other value is entered into this register, the write-protection is active. When write protection is not active, the code word is returned when the register is read. If the write protection is active, the register contains a zero value.

- **R32: Feature register**

[0x1006]

This register specifies the operation modes of the terminal.

Feature bit no.				Description of the operation mode		
Bit 0				1	User scaling (R33, R34 [► 40]) active [0]	
Bit 1				1	Manufacturer scaling (R19, R20 [► 39]) active [1]	
Bit 2				1	Watchdog timer active [1] In the delivery state, the watchdog timer is switched on.	
Bit 3				1	Sign / amount representation [0] Signed amount representation is active instead of two's complement representation. (-1 = 0x8001).	
Bit 4				1	Siemens output format [0] This bit is used for inserting status information on the lowest 3 bits (see below).	
Bit 5				1	Activates filter constant in R37 [0]	
Bit 6				1	Deactivates the measuring current for open-circuit recognition	
Bit 7				-	Reserved, don't change	
Bit 8				1	Reference temperature switched off [0] (R21 [► 39]).	
Bit 9				-	Reserved, don't change	
Bit 10				1	Checking of the lower measuring range limit not applicable. [0]	
Bit						
15	14	13	12	Element	Valid measuring range	
0	0	0	0	Type: L	-25°C to 900°C	
0	0	0	1	Type: K	-100°C to 1370°C	
0	0	1	0	Type: J	-100°C to 1200°C	
0	0	1	1	Type: E	-100°C to 1000°C	
0	1	0	0	Type: T	-100°C to 400°C	
0	1	0	1	Type: N	-100°C to 1300°C	
0	1	1	0	Type: U	-25°C to 600°C	
0	1	1	1	Type: B	600 °C to 1800 °C	
1	0	0	0	Type: R	0 °C to 1700 °C	
1	0	0	1	Type: S	0 °C to 1700 °C	
				Output in μV Resolution	Valid measuring range	
1	1	0	1	1 μV^*	1.6 μV^{**}	$\pm 30 \text{ mV}$
1	1	1	0	2 μV^*	3.2 μV^{**}	$\pm 60 \text{ mV}$
1	1	1	1	4 μV^*	6.4 μV^{**}	$\pm 120 \text{ mV}$ ($\pm 80 \text{ mV}$ for KL3314)

*) no scaling active

**) only vendor scaling active

Examples:

Bit 15 to 12: 1111, no scaling active:

The output format is as follows: 1 digit is equivalent to 1/16 °C or 4 μV .

Bit 15 to 12: 1111, only vendor scaling activated via bit 1 of the Feature register:

The output format is as follows: 1 digit is equivalent to 1/10 °C or 6.4 μV .

If the Siemens output format is selected, the lowest three bits are used for status evaluation. The process data is mapped in bits 15 to 3, with bit 15 representing the sign bit. Scaling of the measured value according to the Siemens standard has to be done via user scaling (R33, R34 [► 40]).

Measured value	Bit 15...3	Bit 2 X	Bit1 Error	Bit 0 Overflow
Out of range		0	0	1
In range	Process data	0	0	0

- **R33: User scaling - offset (B_w)**

16-bit signed integer

This register contains the offset of the user linear equation (Eq. 1.7 [► 12]). The linear equation is enabled via register R32 [► 40].

- **R34: User scaling - gain (A_w)**
16-bit signed integer*2⁻⁸
This register contains the scaling factor of the user linear equation (Eq. 1.7 [► 12]). The linear equation is enabled via register R32 [► 40].
- **R35 and R36: reserved**
- **R37: Filter constant**
[0x0000]

● Applies to all terminals from firmware version 3x.



This documentation applies to all terminals from firmware version 3x. The version information can be found on the right-hand side of the terminal in the serial number: xxxx3xxx.

Example: 52983A2A => the firmware version is 3A.

Filter constant	First notch [Hz]	Conversion time [ms]
0x0000	25	250
0x50	100	65
0xA0	50	125
0x140	25	250
0x280	12.5	500

5.5 Control and status byte

Control byte for process data exchange

The control byte is transferred from the controller to the terminal. The control byte is not used for KL331x and KL3302.

Status byte for process data exchange

The status byte is transmitted from the controller to the terminal. It contains various status bits of the analog input channel:

Status byte:

- Bit 7 = 0_{bin}
- Bit 6 = 1_{bin}: Error (general error bit)
- Bit 5 to bit 2: reserved
- Bit 1 = 1_{bin}: Overrange
- Bit 0 = 1_{bin}: Underrange

Compensation

The terminals are compensated when delivered.

In order to compensate tolerances of the external components, gain and offset registers for compensating the thermocouple voltage are implemented for each channel, i.e. R17 (thermocouple voltage offset) and R18 (thermocouple voltage gain). For compensating the cold junction temperature (temperature at the transition between the thermocouple and the terminal contacts), a gain register (R21) is implemented, which is identical for both sets of registers.

Compensation can be carried out as follows:

First of all the offset calibration is carried out with 0 V input voltage, reference temperature deactivated and linearization switched off. 0xF100 is entered in the feature register.

This is followed by gain compensation with a maximum voltage of 125 mV (typical value: 70 mV). With this terminal setting with vendor scaling deactivated, the voltage is output in 4 µV per digit.

Gain and offset compensation of the thermocouple voltage is carried out separately for each channel.

In the next step, the temperature of the cold junction is compensated.

To this end, a thermocouple has to be selected via the feature register, and cold junction temperature compensation must be active (R32 0x1006 type K). With short-circuited inputs (0 V), the temperature of the terminal contacts is determined, and the temperature output by the terminal (measured via an internal temperature sensor) is set accordingly (via R21).

The cold junction temperature only has to be calibrated once for each terminal, i.e. R21 is identical for both channels.

5.5.1 Register communication

Register access via process data exchange

- **Bit 7=1: Register mode**
If bit 7 of the control byte is set, the first two bytes of the user data are not used for process data exchange but written into the register set of the terminal or read from it.
- **Bit 6=0: read, bit 6=1: write**
Bit 6 of the control bytes is used to specify whether a register should be read or written.
 - **Bit 6=0:** A register is read without changing it. The value can be found in the input process image.
 - **Bit 6=1:** The user data are written into a register. The process is complete once the status byte in the input process image has returned an acknowledgment (see example).
- **Bit 0 to 5: Address**
The address of the register to be addressed is entered in bits 0 to 5 of the control byte.

Control byte in register mode (REG=1)

MSB

REG=1	W/R	A5	A4	A3	A2	A1	A0
-------	-----	----	----	----	----	----	----

REG = 0_{bin}: Process data exchange
 REG = 1_{bin}: Access to register structure

W/R = 0_{bin}: Read register
 W/R = 1_{bin}: Write register

A5..A0 = register address
 Addresses A5..A0 can be used to address a total of 64 registers.

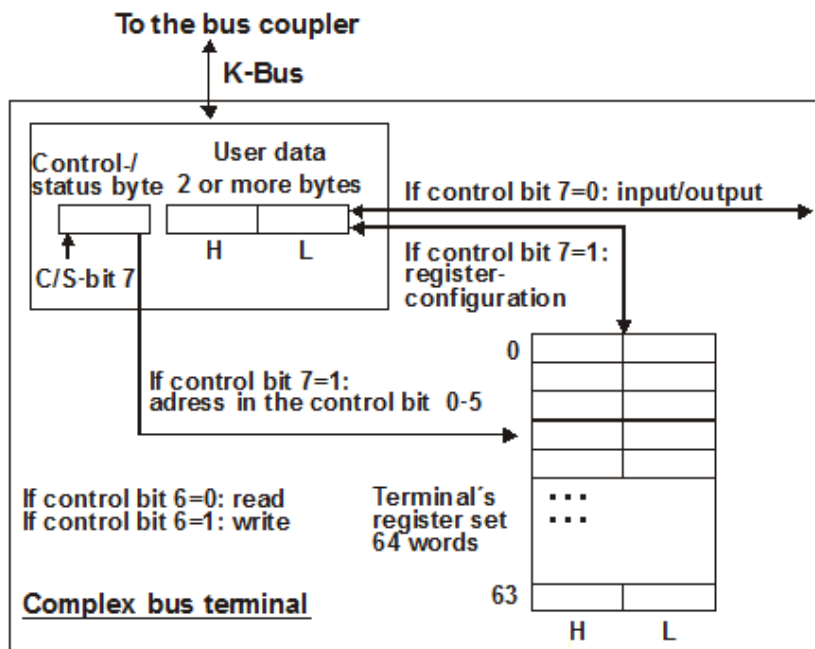

Fig. 23: Register mode control byte

The control or status byte occupies the lowest address of a logical channel. The corresponding register values are located in the following 2 data bytes. (The BK2000 is an exception: here, an unused data byte is inserted after the control or status byte, and the register value is therefore placed on a word boundary).

Example 1:

Reading of register 8 in the BK2000 with a KL3312 and the end terminal:

If the following bytes are transferred from the controller to the terminal,

Byte	Byte 3	Byte 2	Byte 1	Byte 0
Name	DataOUT 1	DataOUT 0	Not used	Control byte
Value	0xXX	0xXX	0xXX	0x88

The terminal returns the following type identifier (0x0CF0 corresponds to unsigned integer 3312)

Byte	Byte 3	Byte 2	Byte 1	Byte 0
Name	DataIN 1	DataIN 0	Not used	Status byte
Value	0x0C	0xF0	0x00	0x88

Example 2:

Writing of register 31 in the BK2000 with an intelligent terminal and the end terminal:

If the following bytes (code word) are transferred from the controller to the terminal,

Byte	Byte 3	Byte 2	Byte 1	Byte 0
Name	DataOUT 1	DataOUT 0	Not used	Control byte
Value	0x12	0x35	0xXX	0xDF

The code word is set, and the terminal returns the register address with bit 7 for register access as acknowledgment.

Byte	Byte 3	Byte 2	Byte 1	Byte 0
Name	DataIN 1	DataIN 0	Not used	Status byte
Value	0x00	0x00	0x00	0x9F

5.6 Examples of Register Communication

The numbering of the bytes in the examples corresponds to the display without word alignment.

5.6.1 Example 1: reading the firmware version from Register 9

Output Data

Byte 0: Control byte	Byte 1: DataOUT1, high byte	Byte 2: DataOUT1, low byte
0x89 (1000 1001 _{bin})	0xXX	0xXX

Explanation:

- Bit 0.7 set means: Register communication switched on.
- Bit 0.6 not set means: reading the register.
- Bits 0.5 to 0.0 specify the register number 9 with 00 1001_{bin}.
- The output data word (byte 1 and byte 2) has no meaning during read access. To change a register, write the required value into the output word.

Input Data (answer of the bus terminal)

Byte 0: Status byte	Byte 1: DataIN1, high byte	Byte 2: DataIN1, low byte
0x89	0x33	0x41

Explanation:

- The terminal returns the value of the control byte as a receipt in the status byte.
- The terminal returns the firmware version 0x3341 in the input data word (byte 1 and byte 2). This is to be interpreted as an ASCII code:
 - ASCII code 0x33 represents the digit 3

- ASCII code 0x41 represents the letter A
The firmware version is thus 3A.

5.6.2 Example 2: Writing to an user register

● Code word

i In normal mode all user registers are read-only with the exception of Register 31. In order to deactivate this write protection you must write the code word (0x1235) into Register 31. If a value other than 0x1235 is written into Register 31, write protection is reactivated. Please note that changes to a register only become effective after restarting the terminal (power-off/power-on).

I. Write the code word (0x1235) into Register 31.

Output Data

Byte 0: Control byte	Byte 1: DataOUT1, high byte	Byte 2: DataOUT1, low byte
0xDF (1101 1111 _{bin})	0x12	0x35

Explanation:

- Bit 0.7 set means: Register communication switched on.
- Bit 0.6 set means: writing to the register.
- Bits 0.5 to 0.0 specify the register number 31 with 01 1111_{bin}.
- The output data word (byte 1 and byte 2) contains the code word (0x1235) for deactivating write protection.

Input Data (answer of the bus terminal)

Byte 0: Status byte	Byte 1: DataIN1, high byte	Byte 2: DataIN1, low byte
0x9F (1001 1111 _{bin})	0xFF	0xFF

Explanation:

- The terminal returns a value as a receipt in the status byte that differs only in bit 0.6 from the value of the control byte.
- The input data word (byte 1 and byte 2) is of no importance after the write access. Any values still displayed are invalid!

II. Read Register 31 (check the set code word)

Output Data

Byte 0: Control byte	Byte 1: DataOUT1, high byte	Byte 2: DataOUT1, low byte
0x9F (1001 1111 _{bin})	0xFF	0xFF

Explanation:

- Bit 0.7 set means: Register communication switched on.
- Bit 0.6 not set means: reading the register.
- Bits 0.5 to 0.0 specify the register number 31 with 01 1111_{bin}.
- The output data word (byte 1 and byte 2) has no meaning during read access.

Input Data (answer of the bus terminal)

Byte 0: Status byte	Byte 1: DataIN1, high byte	Byte 2: DataIN1, low byte
0x9F (1001 1111 _{bin})	0x12	0x35

Explanation:

- The terminal returns the value of the control byte as a receipt in the status byte.
- The terminal returns the current value of the code word register in the input data word (byte 1 and byte 2).

III. Write to Register 32 (change contents of the feature register)

Output data

Byte 0: Control byte	Byte 1: DataIN1, high byte	Byte 2: DataIN1, low byte
0xE0 (1110 0000 _{bin})	0x00	0x02

Explanation:

- Bit 0.7 set means: Register communication switched on.
- Bit 0.6 set means: writing to the register.
- Bits 0.5 to 0.0 indicate register number 32 with 10 0000_{bin}.
- The output data word (byte 1 and byte 2) contains the new value for the feature register.

⚠ CAUTION

Observe the register description!

The value of 0x0002 given here is just an example!

The bits of the feature register change the properties of the terminal and have a different meaning, depending on the type of terminal. Refer to the description of the feature register of your terminal (chapter *Register description*) regarding the meaning of the individual bits before changing the values.

Input data (response from the Bus Terminal)

Byte 0: Status byte	Byte 1: DataIN1, high byte	Byte 2: DataIN1, low byte
0xA0 (1010 0000 _{bin})	0xFF	0xFF

Explanation:

- The terminal returns a value as a receipt in the status byte that differs only in bit 0.6 from the value of the control byte.
- The input data word (byte 1 and byte 2) is of no importance after the write access. Any values still displayed are invalid!

IV. Read Register 32 (check changed feature register)

Output Data

Byte 0: Control byte	Byte 1: DataOUT1, high byte	Byte 2: DataOUT1, low byte
0xA0 (1010 0000 _{bin})	0xFF	0xFF

Explanation:

- Bit 0.7 set means: Register communication switched on.
- Bit 0.6 not set means: reading the register.
- Bits 0.5 to 0.0 indicate register number 32 with 10 0000_{bin}.
- The output data word (byte 1 and byte 2) has no meaning during read access.

Input Data (answer of the bus terminal)

Byte 0: Status byte	Byte 1: DataIN1, high byte	Byte 2: DataIN1, low byte
0xA0 (1010 0000 _{bin})	0x00	0x02

Explanation:

- The terminal returns the value of the control byte as a receipt in the status byte.
- The terminal returns the current value of the feature register in the input data word (byte 1 and byte 2).

V. Write Register 31 (reset code word)

Output Data

Byte 0: Control byte	Byte 1: DataOUT1, high byte	Byte 2: DataOUT1, low byte
0xDF (1101 1111 _{bin})	0x00	0x00

Explanation:

- Bit 0.7 set means: Register communication switched on.
- Bit 0.6 set means: writing to the register.
- Bits 0.5 to 0.0 specify the register number 31 with 01 1111_{bin}.
- The output data word (byte 1 and byte 2) contains 0x0000 for reactivating write protection.

Input Data (answer of the bus terminal)

Byte 0: Status byte	Byte 1: DataIN1, high byte	Byte 2: DataIN1, low byte
0x9F (1001 1111 _{bin})	0xFF	0xFF

Explanation:

- The terminal returns a value as a receipt in the status byte that differs only in bit 0.6 from the value of the control byte.
- The input data word (byte 1 and byte 2) is of no importance after the write access. Any values still displayed are invalid!

6 Appendix

6.1 Support and Service

Beckhoff and their partners around the world offer comprehensive support and service, making available fast and competent assistance with all questions related to Beckhoff products and system solutions.

Beckhoff's branch offices and representatives

Please contact your Beckhoff branch office or representative for local support and service on Beckhoff products!

The addresses of Beckhoff's branch offices and representatives round the world can be found on her internet pages:

<http://www.beckhoff.com>

You will also find further documentation for Beckhoff components there.

Beckhoff Headquarters

Beckhoff Automation GmbH & Co. KG

Huelshorstweg 20
33415 Verl
Germany

Phone: +49 5246 963 0
Fax: +49 5246 963 198
e-mail: info@beckhoff.com

Beckhoff Support

Support offers you comprehensive technical assistance, helping you not only with the application of individual Beckhoff products, but also with other, wide-ranging services:

- support
- design, programming and commissioning of complex automation systems
- and extensive training program for Beckhoff system components

Hotline: +49 5246 963 157
Fax: +49 5246 963 9157
e-mail: support@beckhoff.com

Beckhoff Service

The Beckhoff Service Center supports you in all matters of after-sales service:

- on-site service
- repair service
- spare parts service
- hotline service

Hotline: +49 5246 963 460
Fax: +49 5246 963 479
e-mail: service@beckhoff.com

Table of figures

Fig. 1	KL3311, KL3312 and KL3314.....	8
Fig. 2	Principle of the thermocouple	10
Fig. 3	Data Flow.....	12
Fig. 4	Spring contacts of the Beckhoff I/O components.....	13
Fig. 5	Attaching on mounting rail	14
Fig. 6	Disassembling of terminal.....	15
Fig. 7	Power contact on left side.....	16
Fig. 8	Standard wiring.....	18
Fig. 9	Pluggable wiring	18
Fig. 10	High Density Terminals.....	19
Fig. 11	Connecting a cable on a terminal point	20
Fig. 12	KL3311 - Connection and LEDs	22
Fig. 13	KL3312, KL3302 - Connection and LEDs.....	23
Fig. 14	KL3314 - Connection and LEDs	24
Fig. 15	KL3312 - Connection of ground, shield und earthing (left: earthed thermocouple, right: non-earthed thermocouple).....	25
Fig. 16	KS2000 configuration software.....	28
Fig. 17	Settings of KL3314 via visualisation of TwinCAT 3	30
Fig. 18	Opening the *. tzip archive.....	30
Fig. 19	Search of the existing HW configuration for the EtherCAT configuration of the example	31
Fig. 20	Mapping in the Lightbus Coupler - example for KL3312, KL3302	32
Fig. 21	Mapping in the Profibus Coupler - example for KL3312, KL3302.....	32
Fig. 22	Mapping in the Interbus Coupler - example for KL3312, KL3302.....	33
Fig. 23	Register mode control byte.....	43