

**Documentation**

# **KL3361 and KL3362**

**Oscilloscope Terminal**

**Version: 2.1.0**  
**Date: 2019-02-26**

**BECKHOFF**



# Table of contents

<b>1 Foreword .....</b>	<b>5</b>
1.1 Notes on the documentation.....	5
1.2 Safety instructions .....	6
1.3 Documentation issue status .....	7
<b>2 Product overview.....</b>	<b>9</b>
2.1 General.....	9
2.2 KL3361 - Single-channel oscilloscope terminal.....	10
2.3 Technical Data of the KL3361 .....	11
2.4 KL3362 - two-channel oscilloscope terminal .....	12
2.5 Technical Data of the KL3362 .....	13
2.6 Trigger units.....	14
<b>3 Mounting and wiring.....</b>	<b>15</b>
3.1 Instructions for ESD protection.....	15
3.2 Installation on mounting rails .....	15
3.3 Installation instructions for enhanced mechanical load capacity .....	18
3.4 Connection .....	19
3.4.1 Connection system .....	19
3.4.2 Wiring.....	21
3.4.3 Shielding .....	22
3.5 Connecting the KL3361 .....	23
3.6 Connecting the KL3362 .....	25
3.7 ATEX - Special conditions (standard temperature range) .....	26
3.8 ATEX Documentation .....	27
<b>4 Configuration software KS2000 .....</b>	<b>28</b>
4.1 KS2000 - Introduction.....	28
4.2 Parameterization with KS2000 .....	30
4.3 Masks for KL3361.....	32
4.3.1 Trigger logic for KL3361 .....	32
4.3.2 Trigger values for KL3361 .....	32
4.3.3 Process data for KL3361 .....	34
4.4 Masks for KL3362.....	34
4.4.1 Trigger logic for KL3362 .....	34
4.4.2 General settings for KL3362 .....	36
4.4.3 Trigger values for KL3362 .....	37
4.4.4 Process data for KL3362 .....	38
4.5 Settings in detail .....	39
4.5.1 Trigger logic.....	39
4.5.2 General settings.....	41
4.5.3 Trigger values .....	42
4.5.4 Output process data .....	43
4.5.5 Input process data .....	45
4.6 Sample program for KL register communication via EtherCAT on KL3314 exemplary .....	46
<b>5 Access from the user program .....</b>	<b>49</b>

5.1	Process image .....	50
5.1.1	Process image of the KL3361 .....	50
5.1.2	Process image of the KL3362 .....	50
5.1.3	Control and status bytes .....	51
5.2	RAM and ROM register .....	55
5.2.1	Register overview .....	55
5.2.2	Register description .....	56
5.2.3	Examples of Register Communication .....	64
<b>6</b>	<b>Appendix .....</b>	<b>67</b>
6.1	Support and Service .....	67

# 1 Foreword

## 1.1 Notes on the documentation

### Intended audience

This description is only intended for the use of trained specialists in control and automation engineering who are familiar with the applicable national standards.

It is essential that the documentation and the following notes and explanations are followed when installing and commissioning these components.

It is the duty of the technical personnel to use the documentation published at the respective time of each installation and commissioning.

The responsible staff must ensure that the application or use of the products described satisfy all the requirements for safety, including all the relevant laws, regulations, guidelines and standards.

### Disclaimer

The documentation has been prepared with care. The products described are, however, constantly under development.

We reserve the right to revise and change the documentation at any time and without prior announcement.

No claims for the modification of products that have already been supplied may be made on the basis of the data, diagrams and descriptions in this documentation.

### Trademarks

Beckhoff®, TwinCAT®, EtherCAT®, EtherCAT P®, Safety over EtherCAT®, TwinSAFE®, XFC® and XTS® are registered trademarks of and licensed by Beckhoff Automation GmbH.

Other designations used in this publication may be trademarks whose use by third parties for their own purposes could violate the rights of the owners.

### Patent Pending

The EtherCAT Technology is covered, including but not limited to the following patent applications and patents: EP1590927, EP1789857, DE102004044764, DE102007017835 with corresponding applications or registrations in various other countries.

The TwinCAT Technology is covered, including but not limited to the following patent applications and patents: EP0851348, US6167425 with corresponding applications or registrations in various other countries.

The logo for EtherCAT, featuring the word "EtherCAT" in a bold, black, sans-serif font. A red arrow points from the top of the "A" towards the right, ending above the "T". A registered trademark symbol (®) is located to the right of the "T".

EtherCAT® is registered trademark and patented technology, licensed by Beckhoff Automation GmbH, Germany.

### Copyright

© Beckhoff Automation GmbH & Co. KG, Germany.

The reproduction, distribution and utilization of this document as well as the communication of its contents to others without express authorization are prohibited.

Offenders will be held liable for the payment of damages. All rights reserved in the event of the grant of a patent, utility model or design.

## 1.2 Safety instructions

### Safety regulations

Please note the following safety instructions and explanations!  
Product-specific safety instructions can be found on following pages or in the areas mounting, wiring, commissioning etc.

### Exclusion of liability

All the components are supplied in particular hardware and software configurations appropriate for the application. Modifications to hardware or software configurations other than those described in the documentation are not permitted, and nullify the liability of Beckhoff Automation GmbH & Co. KG.

### Personnel qualification

This description is only intended for trained specialists in control, automation and drive engineering who are familiar with the applicable national standards.

### Description of instructions

In this documentation the following instructions are used.  
These instructions must be read carefully and followed without fail!

#### **DANGER**

##### **Serious risk of injury!**

Failure to follow this safety instruction directly endangers the life and health of persons.

#### **WARNING**

##### **Risk of injury!**

Failure to follow this safety instruction endangers the life and health of persons.

#### **CAUTION**

##### **Personal injuries!**

Failure to follow this safety instruction can lead to injuries to persons.

#### **NOTE**

##### **Damage to environment/equipment or data loss**

Failure to follow this instruction can lead to environmental damage, equipment damage or data loss.



#### **Tip or pointer**

This symbol indicates information that contributes to better understanding.

### 1.3 Documentation issue status

Version	Comment
2.1.0	<ul style="list-style-type: none"> <li>• Design of the safety instructions adapted to IEC 82079-1</li> <li>• Update Technical data</li> <li>• Chapter <i>Instructions for ESD protection</i> added</li> <li>• Update chapter <i>Connection system</i> -&gt; <i>Connection</i></li> <li>• Chapter <i>Installation instructions for enhanced mechanical load capacity</i> added</li> <li>• Example program added to chapter <i>KS2000 Configuration software</i></li> <li>• Correction in chapter <i>Register overview</i></li> <li>• Update structure</li> </ul>
2.0.0	<ul style="list-style-type: none"> <li>• Migration</li> </ul>
1.1.0	<ul style="list-style-type: none"> <li>• Technical data updated</li> <li>• Installation and wiring revised</li> </ul>
1.0	<ul style="list-style-type: none"> <li>• Description of the KL336x parameterization with the KS2000 software corrected (trigger logic details)</li> </ul>
0.6	<ul style="list-style-type: none"> <li>• Description of the KL336x parameterization with the KS2000 software updated (trigger logic details)</li> </ul>
0.5	<ul style="list-style-type: none"> <li>• Description of the process image revised</li> </ul>
0.4	<ul style="list-style-type: none"> <li>• Description of control and status byte extended</li> <li>• Register description updated</li> <li>• English version available</li> </ul>
0.3	<ul style="list-style-type: none"> <li>• Connection instructions extended</li> <li>• Description of the KL336x parameterization with the KS2000 software updated</li> <li>• Register description updated</li> <li>• Description of control and status byte revised</li> </ul>
0.2	<ul style="list-style-type: none"> <li>• Connection instructions added</li> <li>• Description of the KL336x parameterization with the KS2000 software extended</li> <li>• Register description revised</li> </ul>
0.1	<ul style="list-style-type: none"> <li>• First provisional preliminary version</li> </ul>

#### Firmware and hardware versions

Documentation version	KL3361		KL3362	
	Firmware	Hardware	Firmware	Hardware
2.1.0	1D	05	1J	05
2.0.0	1D	04	1J	04
1.1.0	1D	01	1I	01
1.0	1D	01	1F	01
0.6 09.05.2003	1D	01	1D	01
0.5 11.11.2002	1D	01	1D	01
0.4 18.10.2002	1D	01	1D	01
0.3 23.09.2002	1D	01	1D	01
0.2 09.09.2002	1D	01	1D	01
0.1 23.08.2002	1B	00	1D	01

The firmware and hardware versions (delivery state) can be taken from the serial number printed on the side of the terminal.

**Syntax of the serial number**

<b>Structure of the serial number: KK YY FF HH</b>	<b>Sample with ser. no.: 35 04 1F 01:</b>
KK - week of production (calendar week)	35 - week of production 35
YY - year of production	04 - year of production 2004
FF - firmware version	1F - firmware version 1F
HH - hardware version	01 - hardware version 01

## 2 Product overview

### 2.1 General

The KL3361 and KL3362 oscilloscope terminals enable decentralized pre-processing of analog input data. The input values are digitized with a 14-bit resolution and written into an internal memory. A powerful pre-processing processor can determine or monitor the following values, among others:

- Maximum value of a recording
- Minimum value of a recording
- RMS value of a recording
- Arithmetic mean of a recording
- Peak-peak value of a recording
- Envelope monitoring
- Cycle duration
- Most frequent value of a recording
- etc.

The result or all the measured values are transported to the higher-level automation unit.

---

#### ● Supported Bus Couplers



Not all bus couplers support the KL3361 and KL3362 oscilloscope terminals. These include BK2000, BK3000, BK3100, BK4000, BK4500, BK5000, BK7500.

---

#### **KL3361** [▶ 10](#)

**Single-channel** oscilloscope terminal for an input voltage range of **-16 mV to +16 mV**.

Typical application:

Logging and pre-processing of the differential signal from strain gauges in a [bridge circuit](#) [▶ 23](#).

#### **KL3362** [▶ 12](#)

**Two-channel** oscilloscope terminal for an input voltage range of **-10 V to +10 V**.

Typical application:

Logging and pre-processing of standard analog signals.

## 2.2 KL3361 - Single-channel oscilloscope terminal

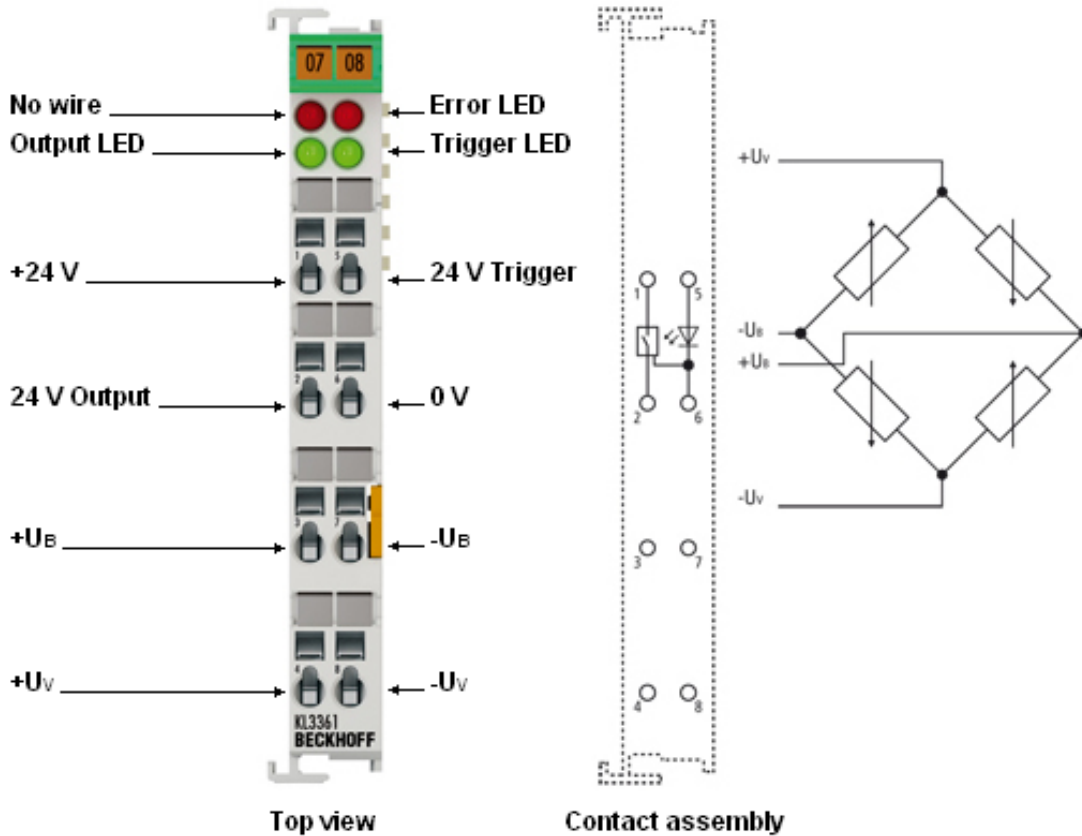

Fig. 1: KL3361

The KL3361 analog input terminal makes it possible to perform non-central preliminary processing of analog values. The input values are digitized with a 14-bit resolution and written into an internal memory. An efficient processor can pre-process the values. Limit values, maximum and minimum values will be determined or monitored. The KL3361 can also carry out envelope monitoring. A trigger starts cyclical processes. The result or all the measured values are transported to the higher-level automation unit.

The supply voltage  $U_v$  can be drawn from the terminal or can be supplied from an external source. The terminal supplies 5 V. The maximum input voltage  $U$  is limited to 10 V.

### LED indicators - meanings

LED	No.	Display
No wire (rot)	A	This LED is on if the wire breaks at the trigger input.
Output (green)	B	This LED is on if the digital output is set.
Error (red)	C	In preparation.
Trigger (green)	D	This LED is on if a signal is present at the trigger input.

For pin assignment see [Connecting the KL3361 \[► 23\]](#).

## 2.3 Technical Data of the KL3361

Single-channel oscilloscope terminal, -20 mV to +20 mV

Technical data	KL3361
Number of inputs	1 analog, 1 trigger
Signal voltage $U_{IN}$	-20 mV to +20 mV
Input resistance	> 1 MOhm ( $U_{IN}$ )
Power supply for the measuring bridge $U_V$	5 V <sub>DC</sub> , 20 mA max.
Resolution	14 bit (plus 1 sign bit)
Sampling rate (configurable)	minimum 100 $\mu$ s, (minimum 10 $\mu$ s for <u>fast sampling</u> <a href="#">▶ 41</a> )
Measuring error (full measuring range)	$\pm 1\%$ of the full scale value
Internal memory	32 kbyte
Bit width in the input process image	2 data words, 1 control byte
Bit width in the output process image	2 data words, 1 status byte
Power supply for the electronics	via the K-bus
Current input from the K-Bus with external supply of the measuring bridge	typically 120 mA
Current consumption from the K-Bus with supply of the measuring bridge (4 x 350 Ohm) via KL3361	typically 140 mA
Dielectric strength	500 V (shielding, base plate / K-Bus)
Permissible ambient temperature range during operation	0°C ... + 55°C
Permissible ambient temperature range during storage	-25°C ... + 85°C
Permissible relative humidity	95 %, no condensation
Vibration/shock resistance	conforms to EN 60068-2-6 / EN 60068-2-27, see also <u>Installation instructions for terminals with increased mechanical load capacity</u> <a href="#">▶ 18</a>
EMC immunity/emission	conforms to EN 61000-6-2 / EN 61000-6-4
Weight	approx. 55 g
Dimensions (W x H x D)	approx. 15 mm x 100 mm x 70 mm
<u>Mounting</u> <a href="#">▶ 15</a>	on 35 mm mounting rail conforms to EN 60715
Installation position	variable
Protection class	IP20
Approvals	CE, ATEX <a href="#">▶ 26</a> , cULus

## 2.4 KL3362 - two-channel oscilloscope terminal

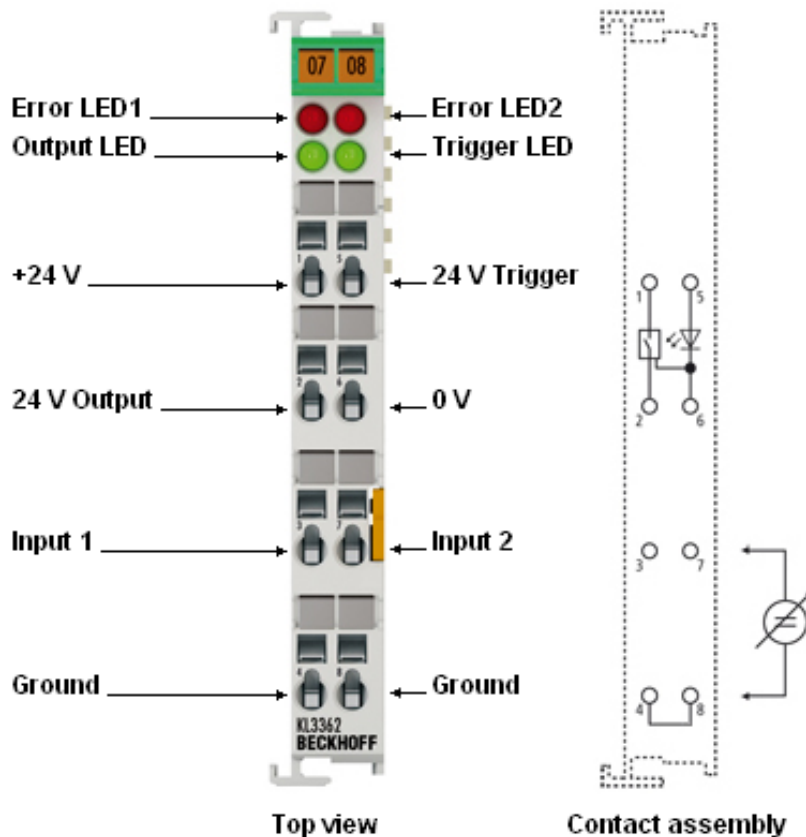

Fig. 2: KL3362

The KL3362 analog input terminal makes it possible to perform non-central preliminary processing of analog values. The input values are digitized with a 14-bit resolution and written into an internal memory. An efficient processor can pre-process the values. Limit values, maximum and minimum values will be determined or monitored. The KL3362 can also carry out envelope monitoring. A trigger starts cyclical processes. The result or all the measured values are transported to the higher-level automation unit.

### LED indicators - meanings

LED	No.	Display
Error 1 (red)	A	in preparation
Output (green)	B	This LED is on if the digital output is set.
Error 2 (red)	C	in preparation
Trigger (green)	D	This LED is on if a signal is present at the trigger input.

For pin assignment see [Connecting the KL3362 \[► 25\]](#).

## 2.5 Technical Data of the KL3362

Two-channel oscilloscope terminal, -10 V to +10 V

Technical data	KL3362
Number of inputs	2 analog, 1 trigger
Signal voltage $U_{IN}$	-10 V to +10 V
Input resistance (IN1-GND, IN2-GND)	> 500 kOhm
Resolution	14 bit (plus 1 sign bit)
Sampling rate (configurable)	minimum 100 $\mu$ s, (minimum 10 $\mu$ s for <u>fast sampling</u> [ <a href="#">▶ 41</a> ])
Measuring error (full measuring range)	$\pm 0,5\%$ of the full scale value
Internal memory	32 kbyte
Bit width in the input process image	Per channel: 2 data words, 1 control byte
Bit width in the output process image	Per channel: 2 data words, 1 status byte
Power supply for the electronics	via the K-bus
Current consumption from K-bus	typically 120 mA
Dielectric strength	500 V (shielding, base plate / K-Bus)
Permissible ambient temperature range during operation	0°C ... + 55°C
Permissible ambient temperature range during storage	-25°C ... + 85°C
Permissible relative humidity	95 %, no condensation
Vibration/shock resistance	conforms to EN 60068-2-6 / EN 60068-2-27
EMC immunity/emission	conforms to EN 61000-6-2 / EN 61000-6-4
Weight	approx. 55 g
Dimensions (W x H x D)	approx. 15 mm x 100 mm x 70 mm
<u>Mounting</u> [ <a href="#">▶ 15</a> ]	on 35 mm mounting rail conforms to EN 60715
Installation position	variable
Protection class	IP20
Approvals	CE, ATEX [ <a href="#">▶ 26</a> ], cULus

## 2.6 Trigger units

The oscilloscope terminals have two trigger units per signal channel. They are configured via sets of registers. The first trigger unit is configured via registers [R40 \[▶ 61\]](#) to R45, the second one via registers [R46 \[▶ 62\]](#) to R51.

Optionally, the following are used as a [trigger source \[▶ 61\]](#):

- an output word of the fieldbus
- a timer
- the analog inputs
- the digital input
- the output of trigger unit 1 for trigger unit 2

The following can be selected as a [trigger event \[▶ 39\]](#):

- rising or falling edge
- a positive or negative pulse that is greater or smaller than a specified pulse width (glitch)

The trigger can be [enabled \[▶ 40\]](#) as follows:

- always, i.e. each trigger event is immediately enabled
- via the signal at the analog inputs or the digital input (each with positive or negative logic and associated switching thresholds).

Enabling of the trigger events can prompt various [actions \[▶ 40\]](#):

- start of recording
- start of a timer (chronometer)
- setting of the digital output
- saving of the current timer value
- resetting of the timer
- starting of a further timer, which is associated with the *Valid Trigger Time* register

The trigger units can be cascaded. This enables extremely flexible triggering depending on the cause of events. For cascaded trigger units, the *Valid Trigger Time* register specifies a time window, during which the subsequent trigger event must occur. If this does not happen, everything is reset and the first trigger event is once again awaited.

## 3 Mounting and wiring

### 3.1 Instructions for ESD protection

#### NOTE

##### **Destruction of the devices by electrostatic discharge possible!**

The devices contain components at risk from electrostatic discharge caused by improper handling.

- Please ensure you are electrostatically discharged and avoid touching the contacts of the device directly.
- Avoid contact with highly insulating materials (synthetic fibers, plastic film etc.).
- Surroundings (working place, packaging and personnel) should be grounded probably, when handling with the devices.
- Each assembly must be terminated at the right hand end with an [EL9011](#) or [EL9012](#) bus end cap, to ensure the protection class and ESD protection.

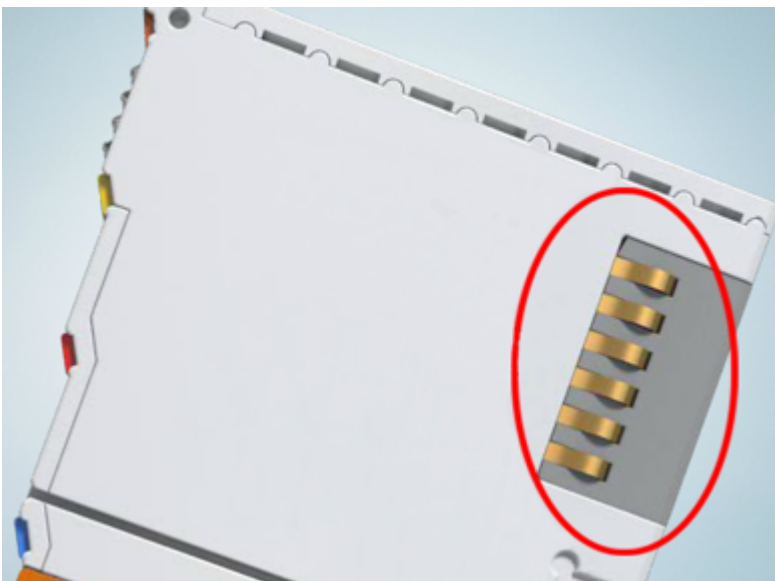

Fig. 3: Spring contacts of the Beckhoff I/O components

### 3.2 Installation on mounting rails

#### **⚠ WARNING**

##### **Risk of electric shock and damage of device!**

Bring the bus terminal system into a safe, powered down state before starting installation, disassembly or wiring of the bus terminals!

## Assembly

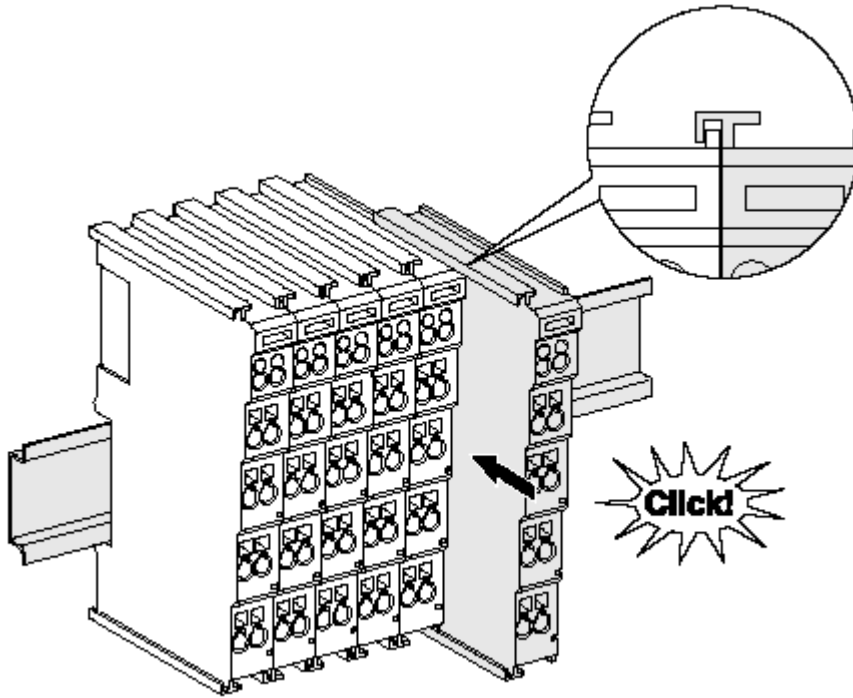

Fig. 4: Attaching on mounting rail

The bus coupler and bus terminals are attached to commercially available 35 mm mounting rails (DIN rails according to EN 60715) by applying slight pressure:

1. First attach the fieldbus coupler to the mounting rail.
2. The bus terminals are now attached on the right-hand side of the fieldbus coupler. Join the components with tongue and groove and push the terminals against the mounting rail, until the lock clicks onto the mounting rail.

If the terminals are clipped onto the mounting rail first and then pushed together without tongue and groove, the connection will not be operational! When correctly assembled, no significant gap should be visible between the housings.

### **i** Fixing of mounting rails

The locking mechanism of the terminals and couplers extends to the profile of the mounting rail. At the installation, the locking mechanism of the components must not come into conflict with the fixing bolts of the mounting rail. To mount the mounting rails with a height of 7.5 mm under the terminals and couplers, you should use flat mounting connections (e.g. countersunk screws or blind rivets).

Disassembly

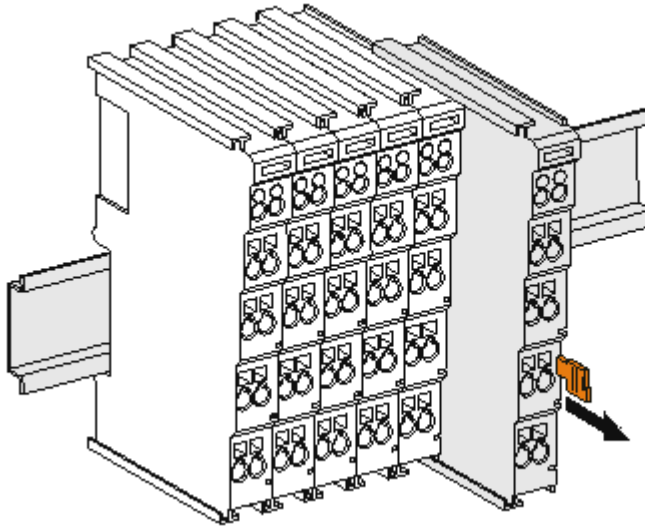

Fig. 5: Disassembling of terminal

Each terminal is secured by a lock on the mounting rail, which must be released for disassembly:

1. Pull the terminal by its orange-colored lugs approximately 1 cm away from the mounting rail. In doing so for this terminal the mounting rail lock is released automatically and you can pull the terminal out of the bus terminal block easily without excessive force.
2. Grasp the released terminal with thumb and index finger simultaneous at the upper and lower grooved housing surfaces and pull the terminal out of the bus terminal block.

**Connections within a bus terminal block**

The electric connections between the Bus Coupler and the Bus Terminals are automatically realized by joining the components:

- The six spring contacts of the K-Bus/E-Bus deal with the transfer of the data and the supply of the Bus Terminal electronics.
- The power contacts deal with the supply for the field electronics and thus represent a supply rail within the bus terminal block. The power contacts are supplied via terminals on the Bus Coupler (up to 24 V) or for higher voltages via power feed terminals.

**● Power Contacts**

**i** During the design of a bus terminal block, the pin assignment of the individual Bus Terminals must be taken account of, since some types (e.g. analog Bus Terminals or digital 4-channel Bus Terminals) do not or not fully loop through the power contacts. Power Feed Terminals (KL91xx, KL92xx or EL91xx, EL92xx) interrupt the power contacts and thus represent the start of a new supply rail.

**PE power contact**

The power contact labeled PE can be used as a protective earth. For safety reasons this contact mates first when plugging together, and can ground short-circuit currents of up to 125 A.

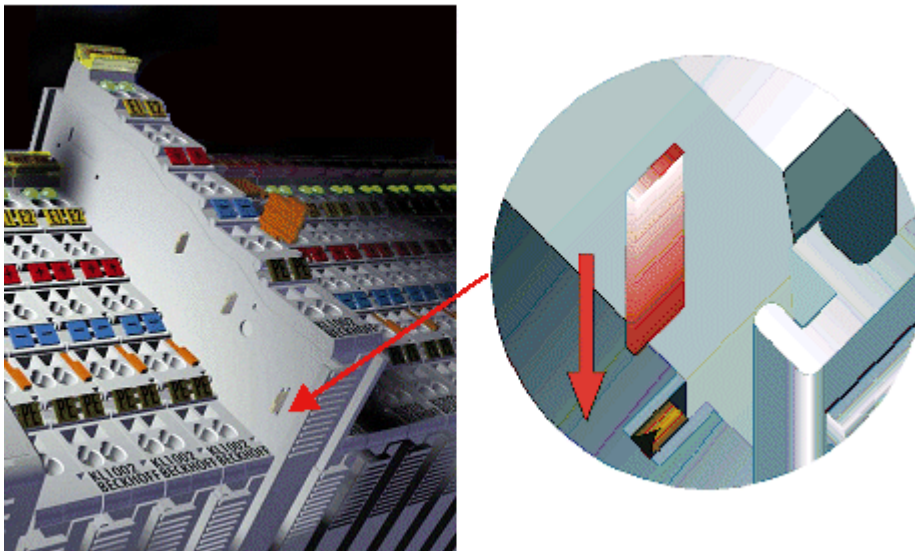

Fig. 6: Power contact on left side

**NOTE**

**Possible damage of the device**

Note that, for reasons of electromagnetic compatibility, the PE contacts are capacitatively coupled to the mounting rail. This may lead to incorrect results during insulation testing or to damage on the terminal (e.g. disruptive discharge to the PE line during insulation testing of a consumer with a nominal voltage of 230 V). For insulation testing, disconnect the PE supply line at the Bus Coupler or the Power Feed Terminal! In order to decouple further feed points for testing, these Power Feed Terminals can be released and pulled at least 10 mm from the group of terminals.

**⚠ WARNING**

**Risk of electric shock!**

The PE power contact must not be used for other potentials!

### 3.3 Installation instructions for enhanced mechanical load capacity

**⚠ WARNING**

**Risk of injury through electric shock and damage to the device!**

Bring the Bus Terminal system into a safe, de-energized state before starting mounting, disassembly or wiring of the Bus Terminals!

**Additional checks**

The terminals have undergone the following additional tests:

Verification	Explanation
Vibration	10 frequency runs in 3 axes
	6 Hz < f < 60 Hz displacement 0.35 mm, constant amplitude
	60.1 Hz < f < 500 Hz acceleration 5 g, constant amplitude
Shocks	1000 shocks in each direction, in 3 axes
	25 g, 6 ms

### Additional installation instructions

For terminals with enhanced mechanical load capacity, the following additional installation instructions apply:

- The enhanced mechanical load capacity is valid for all permissible installation positions
- Use a mounting rail according to EN 60715 TH35-15
- Fix the terminal segment on both sides of the mounting rail with a mechanical fixture, e.g. an earth terminal or reinforced end clamp
- The maximum total extension of the terminal segment (without coupler) is: 64 terminals (12 mm mounting with) or 32 terminals (24 mm mounting with)
- Avoid deformation, twisting, crushing and bending of the mounting rail during edging and installation of the rail
- The mounting points of the mounting rail must be set at 5 cm intervals
- Use countersunk head screws to fasten the mounting rail
- The free length between the strain relief and the wire connection should be kept as short as possible. A distance of approx. 10 cm should be maintained to the cable duct.

## 3.4 Connection

### 3.4.1 Connection system

#### ⚠ WARNING

##### Risk of electric shock and damage of device!

Bring the bus terminal system into a safe, powered down state before starting installation, disassembly or wiring of the bus terminals!

#### Overview

The Bus Terminal system offers different connection options for optimum adaptation to the respective application:

- The terminals of ELxxxx and KLxxxx series with standard wiring include electronics and connection level in a single enclosure.
- The terminals of ESxxxx and KSxxxx series feature a pluggable connection level and enable steady wiring while replacing.
- The High Density Terminals (HD Terminals) include electronics and connection level in a single enclosure and have advanced packaging density.

#### Standard wiring (ELxxxx / KLxxxx)



Fig. 7: Standard wiring

The terminals of ELxxxx and KLxxxx series have been tried and tested for years. They feature integrated screwless spring force technology for fast and simple assembly.

### Pluggable wiring (ESxxxx / KSxxxx)

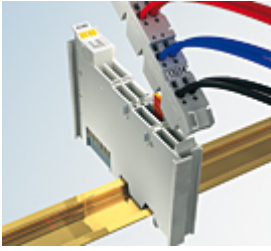

Fig. 8: Pluggable wiring

The terminals of ESxxxx and KSxxxx series feature a pluggable connection level. The assembly and wiring procedure is the same as for the ELxxxx and KLxxxx series. The pluggable connection level enables the complete wiring to be removed as a plug connector from the top of the housing for servicing. The lower section can be removed from the terminal block by pulling the unlocking tab. Insert the new component and plug in the connector with the wiring. This reduces the installation time and eliminates the risk of wires being mixed up.

The familiar dimensions of the terminal only had to be changed slightly. The new connector adds about 3 mm. The maximum height of the terminal remains unchanged.

A tab for strain relief of the cable simplifies assembly in many applications and prevents tangling of individual connection wires when the connector is removed.

Conductor cross sections between 0.08 mm<sup>2</sup> and 2.5 mm<sup>2</sup> can continue to be used with the proven spring force technology.

The overview and nomenclature of the product names for ESxxxx and KSxxxx series has been retained as known from ELxxxx and KLxxxx series.

### High Density Terminals (HD Terminals)



Fig. 9: High Density Terminals

The Bus Terminals from these series with 16 terminal points are distinguished by a particularly compact design, as the packaging density is twice as large as that of the standard 12 mm Bus Terminals. Massive conductors and conductors with a wire end sleeve can be inserted directly into the spring loaded terminal point without tools.

#### ● Wiring HD Terminals

**i** The High Density (HD) Terminals of the ELx8xx and KLx8xx series doesn't support pluggable wiring.

### Ultrasonically "bonded" (ultrasonically welded) conductors

#### ● Ultrasonically "bonded" conductors

**i** It is also possible to connect the Standard and High Density Terminals with ultrasonically "bonded" (ultrasonically welded) conductors. In this case, please note the tables concerning the wire-size width below!

### 3.4.2 Wiring

**⚠ WARNING**

**Risk of electric shock and damage of device!**

Bring the bus terminal system into a safe, powered down state before starting installation, disassembly or wiring of the Bus Terminals!

**Terminals for standard wiring ELxxxx/KLxxxx and for pluggable wiring ESxxxx/KSxxxx**

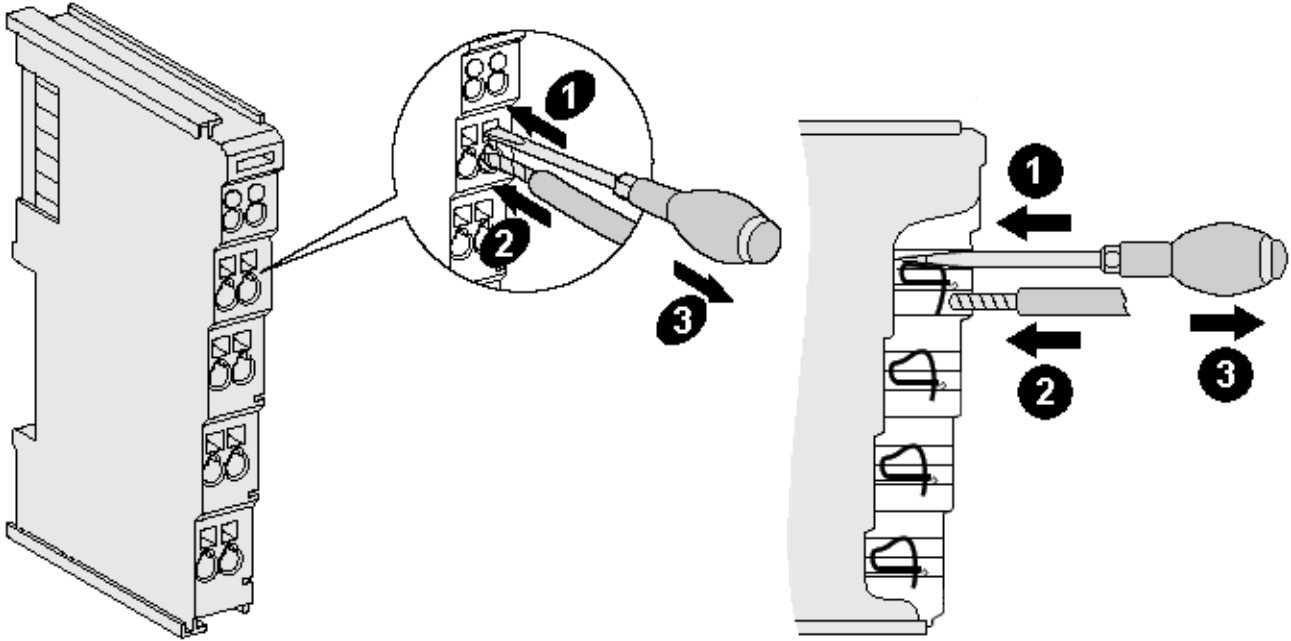

Fig. 10: Connecting a cable on a terminal point

Up to eight terminal points enable the connection of solid or finely stranded cables to the Bus Terminal. The terminal points are implemented in spring force technology. Connect the cables as follows:

1. Open a terminal point by pushing a screwdriver straight against the stop into the square opening above the terminal point. Do not turn the screwdriver or move it alternately (don't toggle).
2. The wire can now be inserted into the round terminal opening without any force.
3. The terminal point closes automatically when the pressure is released, holding the wire securely and permanently.

See the following table for the suitable wire size width.

Terminal housing	ELxxxx, KLxxxx	ESxxxx, KSxxxx
Wire size width (single core wires)	0.08 ... 2.5 mm <sup>2</sup>	0.08 ... 2.5 mm <sup>2</sup>
Wire size width (fine-wire conductors)	0.08 ... 2.5 mm <sup>2</sup>	0,08 ... 2.5 mm <sup>2</sup>
Wire size width (conductors with a wire end sleeve)	0.14 ... 1.5 mm <sup>2</sup>	0.14 ... 1.5 mm <sup>2</sup>
Wire stripping length	8 ... 9 mm	9 ... 10 mm

**High Density Terminals (HD Terminals [▶ 20]) with 16 terminal points**

The conductors of the HD Terminals are connected without tools for single-wire conductors using the direct plug-in technique, i.e. after stripping the wire is simply plugged into the terminal point. The cables are released, as usual, using the contact release with the aid of a screwdriver. See the following table for the suitable wire size width.

Terminal housing	High Density Housing
Wire size width (single core wires)	0.08 ... 1.5 mm <sup>2</sup>
Wire size width (fine-wire conductors)	0.25 ... 1.5 mm <sup>2</sup>
Wire size width (conductors with a wire end sleeve)	0.14 ... 0.75 mm <sup>2</sup>
Wire size width (ultrasonically "bonded" conductors)	only 1.5 mm <sup>2</sup>
Wire stripping length	8 ... 9 mm

### 3.4.3 Shielding



#### Shielding

Encoder, analog sensors and actors should always be connected with shielded, twisted paired wires.

### 3.5 Connecting the KL3361

**⚠ WARNING**

**Risk of injury through electric shock and damage to the device!**

Bring the Bus Terminals system into a safe, de-energized state before starting mounting, disassembly or wiring of the Bus Terminals.

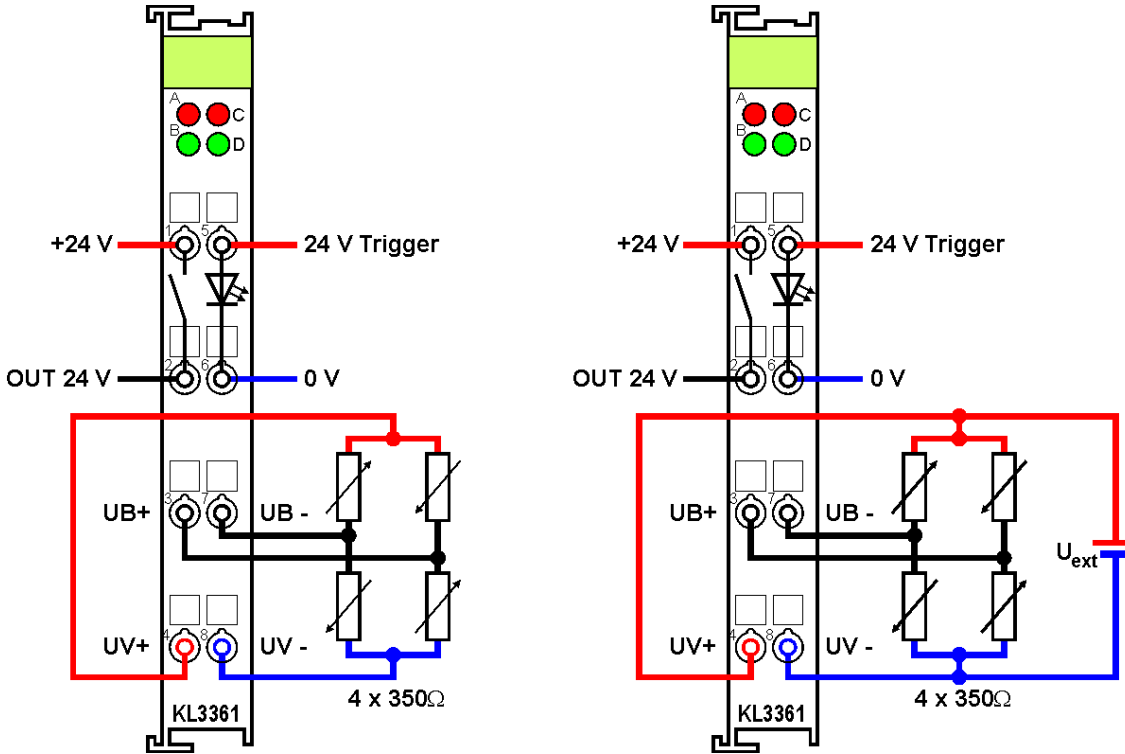

Fig. 11: Connecting the KL3361

The diagram shows the connection of four strain gauges (SG) as a bridge circuit, with supply of the measuring bridge

- through the oscilloscope terminal (left) or
- from an external voltage source  $U_{ext}$  (right).

Terminal point	No.	Connection
+ 24 V	1	Supply voltage for digital output
OUT 24 V	2	Digital output
UB+	3	Input for differential voltage of the measuring bridge
UV+	4	5 V supply voltage for the strain gauges in a bridge circuit or reference input for the external supply voltage of the measuring bridge
24 V Trigger	5	Trigger input
0V	6	Ground for trigger input
UB-	7	Input for differential voltage of the measuring bridge
UV-	8	0 V supply voltage for the strain gauges in a bridge circuit or reference input for the external supply voltage of the measuring bridge

**Supply of the measuring bridge via KL3361**

The total resistance of the measuring bridge should be dimensioned in such a way that the current to be supplied by the oscilloscope terminal at the terminals UV+ and UV- never exceeds 20 mA.

**Supply of the measuring bridge from an external voltage source**

Note the following if the measuring bridge is supplied from an external voltage source:

The external supply voltage

- must also be applied to the UV+ and UV- connections for reference;
- must be within the range +5 V to +10 V;
- must not vary by more than  $\pm 5\%$  during operation.  
Fluctuations of the external supply voltage increase the measurement error!  
After changing the external supply voltage, the oscilloscope terminal has to be restarted for re-balancing!

The internal voltage source switches off automatically, as soon as an external voltage of more than 5 V is applied to the UV+ and UV- terminals of the oscilloscope terminal.

### 3.6 Connecting the KL3362

**⚠ WARNING**

**Risk of injury through electric shock and damage to the device!**

Bring the Bus Terminals system into a safe, de-energized state before starting mounting, disassembly or wiring of the Bus Terminals.

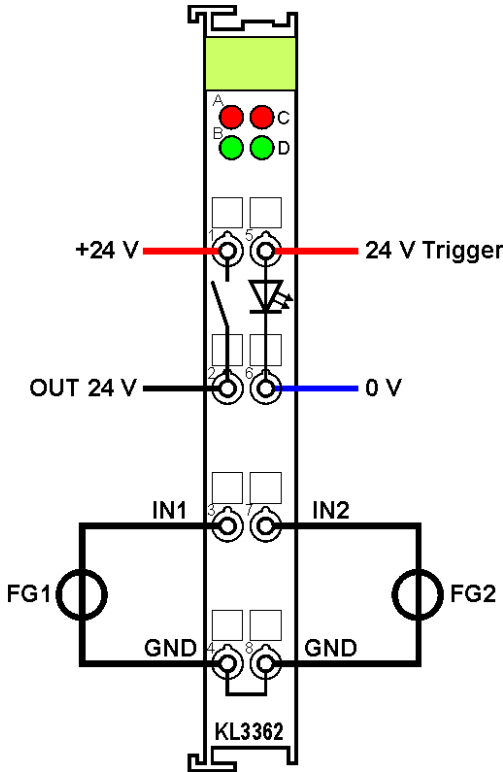

Fig. 12: Connecting the KL3362

The diagram shows the connection of two function generators (FG1, FG2) to the channels of the KL3362 oscilloscope terminal.

Terminal point	No.	Connection
+ 24V	1	Supply voltage for digital output
OUT 24V	2	Digital output
IN 1	3	Oscilloscope input channel 1 ( -10 V to +10 V)
GND	4	Ground for oscilloscope input channel 1 (internally connected with terminal no. 8)
24V Trigger	5	Trigger input
0V	6	Ground for trigger input
IN 2	7	Oscilloscope input channel 2 ( -10 V to +10 V)
GND	8	Ground for oscilloscope input channel 2 (internally connected with terminal no. 4)

### 3.7 ATEX - Special conditions (standard temperature range)

#### ⚠ WARNING

**Observe the special conditions for the intended use of Beckhoff fieldbus components with standard temperature range in potentially explosive areas (directive 94/9/EU)!**

- The certified components are to be installed in a suitable housing that guarantees a protection class of at least IP54 in accordance with EN 60529! The environmental conditions during use are thereby to be taken into account!
- If the temperatures during rated operation are higher than 70°C at the feed-in points of cables, lines or pipes, or higher than 80°C at the wire branching points, then cables must be selected whose temperature data correspond to the actual measured temperature values!
- Observe the permissible ambient temperature range of 0 to 55°C for the use of Beckhoff fieldbus components standard temperature range in potentially explosive areas!
- Measures must be taken to protect against the rated operating voltage being exceeded by more than 40% due to short-term interference voltages!
- The individual terminals may only be unplugged or removed from the Bus Terminal system if the supply voltage has been switched off or if a non-explosive atmosphere is ensured!
- The connections of the certified components may only be connected or disconnected if the supply voltage has been switched off or if a non-explosive atmosphere is ensured!
- The fuses of the KL92xx/EL92xx power feed terminals may only be exchanged if the supply voltage has been switched off or if a non-explosive atmosphere is ensured!
- Address selectors and ID switches may only be adjusted if the supply voltage has been switched off or if a non-explosive atmosphere is ensured!

#### Standards

The fundamental health and safety requirements are fulfilled by compliance with the following standards:

- EN 60079-0:2012+A11:2013
- EN 60079-15:2010

#### Marking

The Beckhoff fieldbus components with standard temperature range certified for potentially explosive areas bear one of the following markings:



II 3G KEMA 10ATEX0075 X Ex nA IIC T4 Gc Ta: 0 ... 55°C

or



II 3G KEMA 10ATEX0075 X Ex nC IIC T4 Gc Ta: 0 ... 55°C

## 3.8 ATEX Documentation

---



**Notes about operation of the Beckhoff terminal systems in potentially explosive areas (ATEX)**

Pay also attention to the continuative documentation

Notes about operation of the Beckhoff terminal systems in potentially explosive areas (ATEX)

that is available in the download area of the Beckhoff homepage <http://www.beckhoff.com!>

---

## 4 Configuration software KS2000

### 4.1 KS2000 - Introduction

The KS2000 configuration software permits configuration, commissioning and parameterization of bus couplers, of the affiliated bus terminals and of Fieldbus Box Modules. The connection between bus coupler / Fieldbus Box Module and the PC is established by means of the serial configuration cable or the fieldbus.



Fig. 13: KS2000 configuration software

#### Configuration

You can configure the Fieldbus stations with the Configuration Software KS2000 offline. That means, setting up a terminal station with all settings on the couplers and terminals resp. the Fieldbus Box Modules can be prepared before the commissioning phase. Later on, this configuration can be transferred to the terminal station in the commissioning phase by means of a download. For documentation purposes, you are provided with the breakdown of the terminal station, a parts list of modules used and a list of the parameters you have modified. After an upload, existing fieldbus stations are at your disposal for further editing.

#### Parameterization

KS2000 offers simple access to the parameters of a fieldbus station: specific high-level dialogs are available for all bus couplers, all intelligent bus terminals and Fieldbus Box modules with the aid of which settings can be modified easily. Alternatively, you have full access to all internal registers of the bus couplers and intelligent terminals. Refer to the register description for the meanings of the registers.

## Commissioning

The KS2000 software facilitates commissioning of machine components or their fieldbus stations: Configured settings can be transferred to the fieldbus modules by means of a download. After a *login* to the terminal station, it is possible to define settings in couplers, terminals and Fieldbus Box modules directly *online*. The same high-level dialogs and register access are available for this purpose as in the configuration phase.

The KS2000 offers access to the process images of the bus couplers and Fieldbus Box modules.

- Thus, the coupler's input and output images can be observed by monitoring.
- Process values can be specified in the output image for commissioning of the output modules.

All possibilities in the *online mode* can be used in parallel with the actual fieldbus mode of the terminal station. The fieldbus protocol always has the higher priority in this case.

## 4.2 Parameterization with KS2000

Connect the configuration interface of your fieldbus coupler with the serial interface of your PC via the configuration cable and start the *KS2000* configuration software.



Click on the *Login* button. The configuration software will now load the information for the connected fieldbus station.

In the sample shown, this is

- a BK9000 Bus Coupler for Ethernet
- a KL1xx2 digital input terminal
- a KL3661 oscilloscope terminal
- a KL9010 Bus end terminal

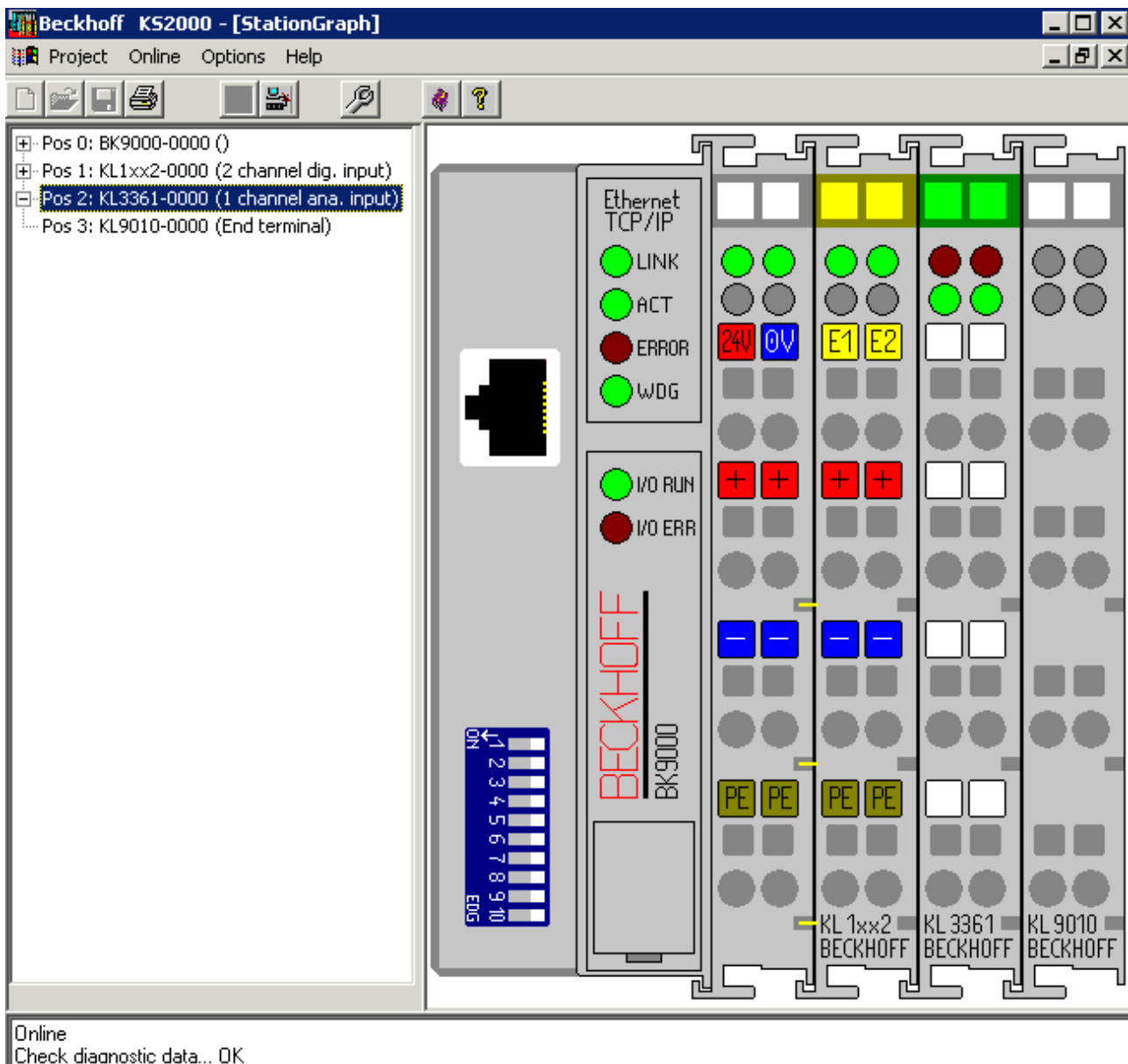

Fig. 14: Display of the fieldbus station in KS2000

The left-hand KS2000 window displays the terminals of the fieldbus station in a tree structure. The right-hand KS2000 window contains a graphic display of the fieldbus station terminals.

In the tree structure of the left-hand window, click on the plus-sign next to the terminal whose parameters you wish to change (item 2 in the sample).

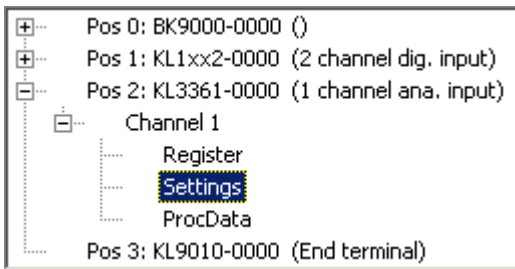

Fig. 15: KS2000 tree branches for channel 1 of the KL3681

Click on *Settings*. You can now change the settings of the oscilloscope terminal.

#### KL3361:

- [Trigger logic \[► 32\]](#)
- [Operating mode and trigger values \[► 32\]](#)
- [Process data \[► 34\]](#)

#### KL3362:

- [Trigger logic \[► 34\]](#)
- [Trigger values \[► 37\]](#)
- [Operation mode \[► 41\]](#)
- [Process data \[► 38\]](#)

## 4.3 Masks for KL3361

### 4.3.1 Trigger logic for KL3361

In the *Trigger logic* tab, you can specify the trigger behavior of the KL3361 oscilloscope terminal.

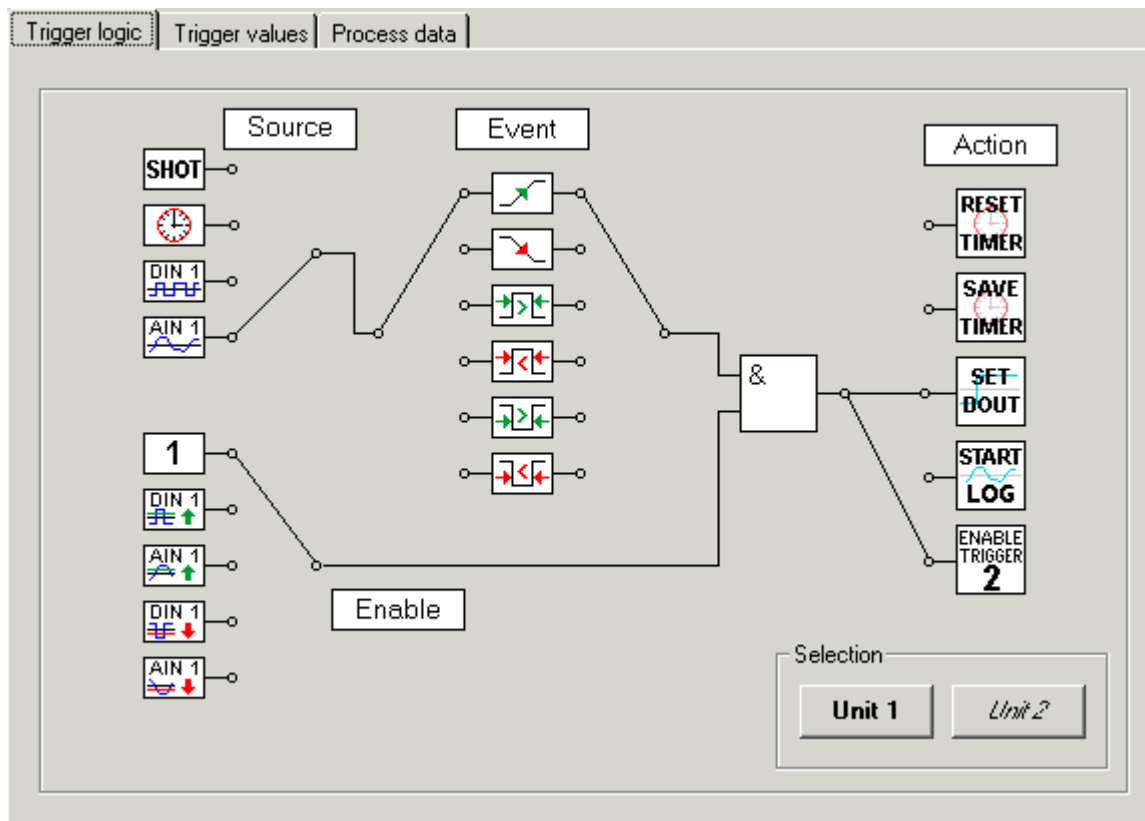

Fig. 16: Trigger logic for KL3361

- **Source**  
Here you can select the trigger source (see [Trigger logic in detail](#) [▶ 39]).
- **Event**  
Here you can specify the trigger event (see [Trigger logic in detail](#) [▶ 39]).
- **Enable**  
Connect the lower input of the And gate with the desired function in order to specify when the And gate should switch through a trigger pulse (see [Trigger logic in detail](#) [▶ 40]).
- **Action**  
Connect the output of the And gate with the desired function in order to specify which task should be triggered (see [Trigger logic in detail](#) [▶ 40]).

### 4.3.2 Trigger values for KL3361

In the *Trigger values* tab, you can set the mode, the scaling and the switching thresholds, the pulse width and the valid trigger time for the two trigger units of the KL3361 oscilloscope terminal.

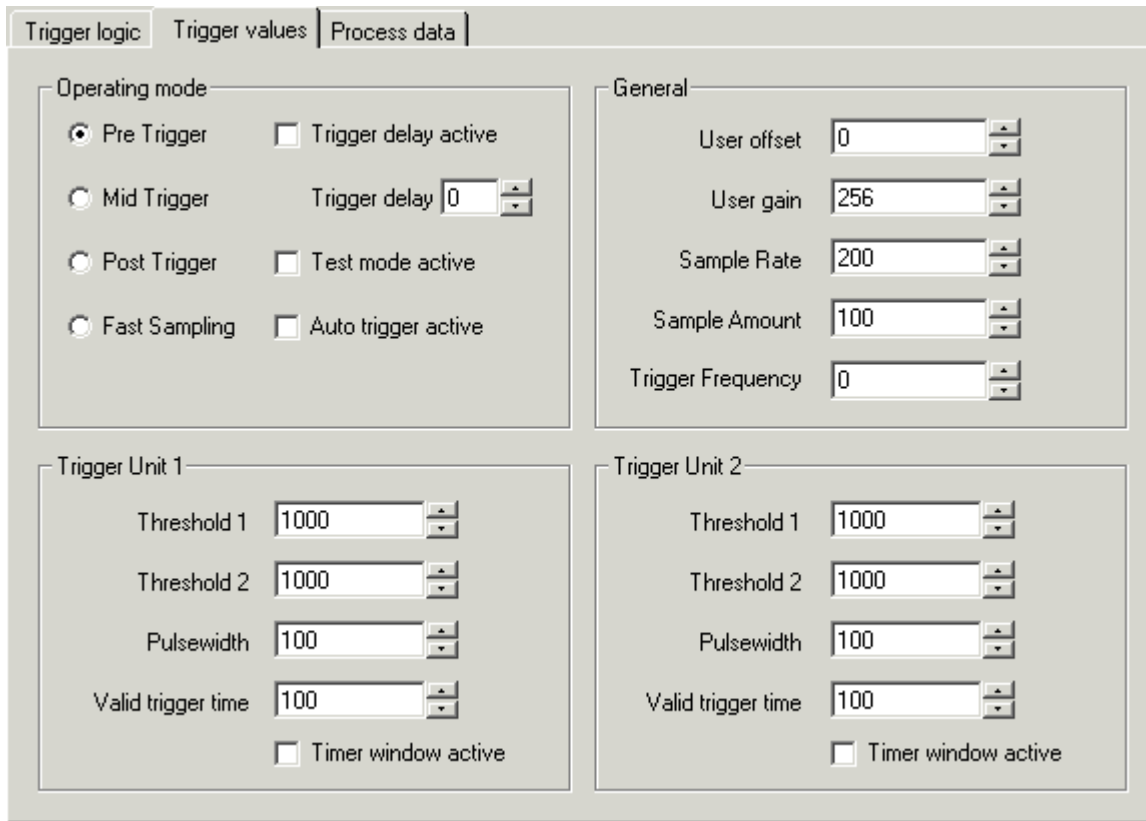

Fig. 17: Trigger values for KL3361

- **Operation mode**  
Here you can specify the trigger type (see [General settings in detail \[► 41\]](#)).
- **General**  
Here you can specify the general trigger settings (see [General settings in detail \[► 41\]](#)).
- **Scaling**  
Here you can specify the scaling (see [General settings in detail \[► 41\]](#)).
- **Trigger unit 1**  
Here you can specify the trigger values for trigger unit 1 (see [Trigger values \[► 42\]](#) in detail).
- **Trigger unit 2**  
Here you can specify the trigger values for trigger unit 2 (see [Trigger values \[► 42\]](#) in detail).

### 4.3.3 Process data for KL3361

In the *Process data* tab, you can specify which data are displayed in the process image of the KL3361 oscilloscope terminal.

Fig. 18: Process data for KL3361

#### Output process image

- **Data word 0**  
For trigger unit 1, select which trigger parameter you wish to specify with data word 0 ([DataOUT0](#) [▶ 50]) of the KL3361 (see [Output process data in detail](#) [▶ 43]).
- **Data word 1**  
For trigger unit 2, select which trigger parameter you wish to specify with data word 1 ([DataOUT1](#) [▶ 50]) of the KL3361 (see [Output process data in detail](#) [▶ 43]).

#### Input process image

- **Data word 0**  
Here you can specify which input value is transferred with data word 0 ([DataIN0](#) [▶ 50]) from the KL3361 to the control (see [Input process data in detail](#) [▶ 45]).
- **Data word 1**  
Here you can specify which input value is transferred with data word 1 ([DataIN1](#) [▶ 50]) from the KL3361 to the control (see [Input process data in detail](#) [▶ 45]).

## 4.4 Masks for KL3362

### 4.4.1 Trigger logic for KL3362

In the *Trigger logic* tab, you can specify the trigger behavior of the KL3362 oscilloscope terminal.

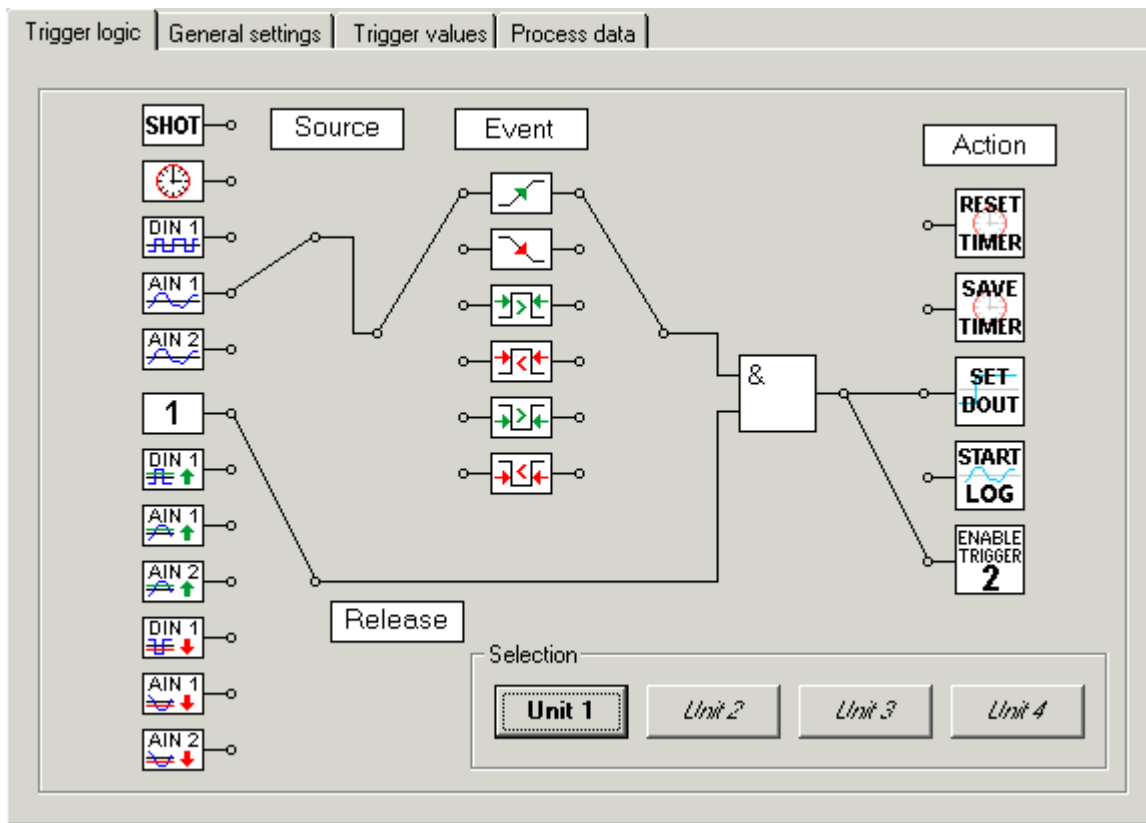

Fig. 19: Trigger logic for KL3362

- **Source**  
Here you can select the trigger source (see [Trigger logic in detail \[▶ 39\]](#)).
- **Event**  
Here you can specify the trigger event (see [Trigger logic in detail \[▶ 39\]](#)).
- **Enable**  
Connect the lower input of the And gate with the desired function in order to specify when the And gate should switch through a trigger pulse (see [Trigger logic in detail \[▶ 40\]](#)).
- **Action**  
Connect the output of the And gate with the desired function in order to specify which task should be triggered (see [Trigger logic in detail \[▶ 40\]](#)).

## 4.4.2 General settings for KL3362

In the *General settings* tab, you can specify the operating mode, general settings and the scaling of both channels of the KL3362 oscilloscope terminal.

The screenshot shows the 'General settings' tab for the KL3362 oscilloscope terminal. The interface is organized into four main sections:

- Operation mode:** Contains four radio buttons: **Pre-Trigger** (selected), **Mid-Trigger**, **Post-Trigger**, and **Fast-Sampling**. It also includes three checkboxes: **Trigger delay active**, **Test mode active**, and **Auto trigger active**. The **Mid-Trigger** section has a numeric input field set to 0.
- General:** Contains three numeric input fields: **Sample-Rate** (200), **Sample-Amount** (100), and **Trigger frequency** (0).
- Scale channel 1:** Contains two numeric input fields: **User offset** (0) and **User gain** (256).
- Scale channel 2:** Contains two numeric input fields: **User offset** (0) and **User gain** (256).

Fig. 20: General settings for KL3362

- **Operation mode**  
Here you can specify the trigger type (see [General settings in detail \[► 41\]](#)).
- **General**  
Here you can specify the general trigger settings (see [General settings in detail \[► 41\]](#)).
- **Scaling channel 1**  
Here you can specify the scaling for channel 1 (see [General settings in detail \[► 41\]](#)).
- **Scaling channel 2**  
Here you can specify the scaling for channel 2 (see [General settings in detail \[► 41\]](#)).

### 4.4.3 Trigger values for KL3362

In the *Trigger values* tab, you can specify the switching thresholds, the pulse width and the valid trigger time for the four trigger units of the KL3362 oscilloscope terminal.

The screenshot shows the 'Trigger values' configuration window for the KL3362 oscilloscope terminal. The window is divided into four quadrants, each representing a trigger unit. The top-left quadrant is for 'Trigger unit 1 (Ch. 1)', the top-right for 'Trigger unit 2 (Ch. 1)', the bottom-left for 'Trigger unit 3 (Ch. 2)', and the bottom-right for 'Trigger unit 4 (Ch. 2)'. Each quadrant contains four spinners for 'Threshold 1', 'Threshold 2', 'Pulsewidth', and 'Valid trigger time', all set to 1000, 1000, 100, and 100 respectively. A 'Timer window active' checkbox is present at the bottom of each quadrant and is currently unchecked.

Fig. 21: Trigger values for KL3362

- **Trigger unit 1**  
Here you can specify the trigger values for trigger unit 1 (see [Trigger values in detail \[► 42\]](#)).
- **Trigger unit 2**  
Here you can specify the trigger values for trigger unit 2 (see [Trigger values in detail \[► 42\]](#)).
- **Trigger unit 3**  
Here you can specify the trigger values for trigger unit 3 (see [Trigger values in detail \[► 42\]](#)).
- **Trigger unit 4**  
Here you can specify the trigger values for trigger unit 4 (see [Trigger values in detail \[► 42\]](#)).

#### 4.4.4 Process data for KL3362

In the *Process data* tab, you can specify which data are displayed in the process image of the KL3362 oscilloscope terminal.

Fig. 22: Process data for KL3362

##### Output process image

- **Data word 0**  
For trigger unit 1, select which trigger parameter you wish to specify with data word 0 ([DataOUT0, channel 1](#) [▶ 50]) of the KL3362 (see [Output process data in detail](#) [▶ 43]).
- **Data word 1**  
For trigger unit 2, select which trigger parameter you wish to specify with data word 1 ([DataOUT1, channel 1](#) [▶ 50]) of the KL3362 (see [Output process data in detail](#) [▶ 43]).
- **Data word 2**  
For trigger unit 3, select which trigger parameter you wish to specify with data word 2 ([DataOUT0, channel 2](#) [▶ 50]) of the KL3362 (see [Output process data in detail](#) [▶ 43]).
- **Data word 3**  
For trigger unit 4, select which trigger parameter you wish to specify with data word 3 ([DataOUT1, channel 2](#) [▶ 50]) of the KL3362 (see [Output process data in detail](#) [▶ 43]).

##### Input process image

- **Data word 0**  
Here you can specify which input value is transferred with data word 0 ([DataIN0, channel 1](#) [▶ 50]) from the KL3362 to the controller (see [Input process data in detail](#) [▶ 45]).
- **Data word 1**  
Here you can specify which input value is transferred with data word 1 ([DataIN1, channel 1](#) [▶ 50]) from the KL3362 to the controller (see [Input process data in detail](#) [▶ 45]).





- **Data word 2**  
Here you can specify which input value is transferred with data word 2 ([DataIN0, channel 2 \[▶ 50\]](#)) from the KL3362 to the controller (see [Input process data in detail \[▶ 45\]](#)).
- **Data word 3**  
Here you can specify which input value is transferred with data word 3 ([DataIN1, channel 2 \[▶ 50\]](#)) from the KL3362 to the controller (see [Input process data in detail \[▶ 45\]](#)).

## 4.5 Settings in detail

### 4.5.1 Trigger logic

#### Source







You may select one of the following trigger sources ([R40 \[▶ 61\]](#)):

	Shot	The trigger pulse is triggered by the fieldbus via a control word.
	Timer	The trigger pulse is triggered at regular intervals by a timer. The frequency of the timer can be specified under <a href="#">General trigger settings [▶ 41]</a> .
	Digital input	The trigger pulse is triggered by the trigger input (24 V trigger).
	Analog input 1	The trigger pulse is triggered by analog input 1.
	Analog input 2	The trigger pulse is triggered by analog input 2.

(KL3362 only)







#### Event

Here you can specify the event ([R40 \[▶ 61\]](#)) that triggers the trigger.

	Rising edge (default)	The trigger unit responds to the rising edge of the input signal. The associated threshold level can be specified via the <a href="#">Trigger values [▶ 42]</a> tab.
	Falling edge	The trigger unit responds to the falling edge of the input signal. The associated threshold level can be specified via the <a href="#">Trigger values [▶ 42]</a> tab.
	Positive pulse longer than set pulse width	The trigger unit responds if the positive pulse width is longer than the configured pulse width, which can be specified via the <a href="#">Trigger values [▶ 42]</a> tab.
	Positive pulse shorter than set pulse width	The trigger unit responds if the positive pulse width is shorter than the configured pulse width, which can be specified via the <a href="#">Trigger values [▶ 42]</a> tab.
	Negative pulse longer than set pulse width	The trigger unit responds if the negative pulse width is longer than the configured pulse width, which can be specified via the <a href="#">Trigger values [▶ 42]</a> tab.
	Negative pulse shorter than set pulse width	The trigger unit responds if the negative pulse width is shorter than the configured pulse width, which can be specified via the <a href="#">Trigger values [▶ 42]</a> tab.







## Enable

Connect the lower input of the And gate with the desired function in order to specify when the And gate should switch through a trigger pulse ([R40.1](#) ▶ [61](#)).

	Always enabled	The trigger pulse is always switched through.
	Digital input High	The trigger pulse is switched through, if the trigger input (24 V trigger) of the oscilloscope terminal is on High potential.
	Analog input 1 above switching threshold	The trigger pulse is switched through, if the signal at analog input 1 of the oscilloscope terminal increases above the switching threshold 2. The threshold level can be specified via the <a href="#">Trigger values</a> ▶ <a href="#">42</a> tab.
	Analog input 2 above switching threshold	The trigger pulse is switched through, if the signal at analog input 2 of the oscilloscope terminal increases above the switching threshold 2. The threshold level can be specified via the <a href="#">Trigger values</a> ▶ <a href="#">42</a> tab.
(KL3362 only)		
	Digital input Low	The trigger pulse is switched through, if the trigger input (24 V trigger) of the oscilloscope terminal is on Low potential.
	Analog input 1 below switching threshold	The trigger pulse is switched through, if the signal at analog input 1 of the oscilloscope terminal decreases below the specified switching threshold 2. The threshold level can be specified via the <a href="#">Trigger values</a> ▶ <a href="#">42</a> tab.
	Analog input 2 below switching threshold	The trigger pulse is switched through, if the signal at analog input 2 of the oscilloscope terminal decreases below the specified switching threshold 2. The threshold level can be specified via the <a href="#">Trigger values</a> ▶ <a href="#">42</a> tab.
(KL3362 only)		

## Action

Connect the output of the And gate with the desired function in order to specify which task should be triggered.

	Reset the timer (chronometer) to zero ( <a href="#">R40.2</a> ▶ <a href="#">61</a> )	Resets the timer back to zero. The timer will start running again automatically immediately.
	Save timer (chronometer) ( <a href="#">R40.3</a> ▶ <a href="#">61</a> )	Saves the current value of the running timer at the trigger instant.
	Set digital output ( <a href="#">R40.4</a> ▶ <a href="#">61</a> )	Sets the digital output, e.g. to the synchronous triggers of the second oscilloscope channel of a KL3362. This function must be released with bit 2 of the control byte 1 (CB1.2)
	Start recording ( <a href="#">R40.5</a> ▶ <a href="#">61</a> )	Starts the recording
	Enable trigger unit 2 ( <a href="#">R40.5</a> ▶ <a href="#">61</a> )	If the output of the And gate in trigger unit 1 is connected with the function <i>Enable trigger 2</i> , the trigger signal is transferred to trigger unit 2, which can be accessed via the <i>Unit 2</i> button in the <i>Selection</i> field for parameterization.
	Enable trigger unit 3 ( <a href="#">R40.5</a> ▶ <a href="#">61</a> )	If the output of the And gate in trigger unit 2 is connected with the function <i>Enable trigger 3</i> , the trigger signal is transferred to trigger unit 3, which can be accessed via the <i>Unit 3</i> button in the <i>Selection</i> field for parameterization.
(KL3362 only)		
	Enable trigger unit 4 ( <a href="#">R40.5</a> ▶ <a href="#">61</a> )	If the output of the And gate in trigger unit 3 is connected with the function <i>Enable trigger 4</i> , the trigger signal is transferred to trigger unit 4, which can be accessed via the <i>Unit 4</i> button in the <i>Selection</i> field for parameterization.
(KL3362 only)		

## 4.5.2 General settings

### Operation mode

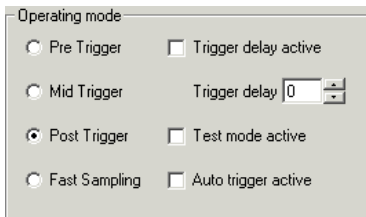

**Pre-trigger** ([R32.8-10](#) [[▶ 58](#)])

Recording ceases as soon as a trigger event occurs.

**Mid-trigger** ([R32.8-10](#) [[▶ 58](#)])

The trigger event is the center of the recording.

**Post-trigger** ([R32.8-10](#) [[▶ 58](#)])  
default

Recording commences as soon as a trigger event occurs.

**Fast sampling** ([R32.8-10](#) [[▶ 58](#)])

Operation with increased sampling rate of up to 10  $\mu$ s:

- The recording can only be started via the trigger input.
- The settings of the trigger units are not taken into account.
- Only the first channel is recorded, even for KL3362.

**Trigger delay active** ([R32.4](#) [[▶ 58](#)])

Switches the trigger delay on.

default: not activated

**Trigger delay** ([R52](#) [[▶ 62](#)])  
default: 0

A trigger delay ( $t_{TD}$ ) can be specified here. The number of skipped samples ( $n_{STD}$ ) is entered as the parameter. The trigger delay thus depends on the sample rate! Sample:  
- Sample Rate:  $T_s = 200 \mu$ s  
- Skipped Samples:  $n_{STD} = 100$   
 $t_{TD} = T_s \times n_{STD} = 200 \mu$ s  $\times$  100 = 20 ms

**Test mode active** ([R32.5](#) [[▶ 58](#)])  
default: not activated

Switches the test mode on. In test mode, a ramp is output instead of converted analog values. It runs from 0 to 0x3FFF and back again.

**Auto-trigger active** ([R32.6](#) [[▶ 58](#)])  
default not activated

Switches the auto trigger function on. With auto trigger switched on, the trigger unit is automatically activated once the preceding event has been evaluated. To this end, bit 0 is toggled in status register 1 (SR1) with each new evaluation.

### General

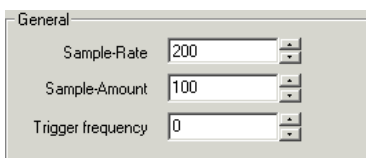

**Sample rate** ([R35](#) [[▶ 58](#)])  
default: 200  $\mu$ s

Interval ( $T_s$ ) between two samples (scans) in microseconds.

The sampling speed is limited to  $T_s = 100 \mu$ s (10 kHz) by the evaluation of the trigger detectors.

Only the **Fast sampling** mode enables sampling at  $T_s = 10 \mu$ s (100 kHz).

**Sample amount** ([R36](#))  
default: 100

Number of sampling values to be recorded. A maximum of 4,000 values can be recorded.

**Trigger frequency** ([R56](#) [[▶ 63](#)])  
default: 0

Here you can specify the trigger frequency of the [timer](#) [[▶ 32](#)].

### Scaling channel 1

**User offset** (R33 [▶ 58])  
default: 0

Here you can enter an offset. Scaling:  
offset = full scale value x parameter / resolution

Sample for KL3361:  $16 \text{ mV} \times 100 / 32767 = 0.049 \text{ mV}$

**User gain** (R34 [▶ 58])  
default: 256

Here you can enter the gain factor for scaling the input value by this factor.

### Scaling channel 2 (KL3362 only)

**User offset** (R33 [▶ 58])  
default: 0

Here you can enter an offset. Scaling:  
offset = full scale value x parameter / resolution

Sample for KL3361:  $16 \text{ mV} \times 100 / 32767 = 0.049 \text{ mV}$

**User gain** (R34 [▶ 58])  
default: 256

Here you can enter the gain factor for scaling the input value by this factor.

## 4.5.3 Trigger values

### Trigger unit 1

**Switching threshold 1** (R41 [▶ 61])  
default: 1000

Here you can specify the switching threshold for the trigger source of trigger unit 1. Scaling:  
Threshold value = full scale value x parameter / resolution

Sample for KL3361:  $16 \text{ mV} \times 1000 / 32767 = 0,488 \text{ mV}$

**Switching threshold 2** (R42 [▶ 62])  
default: 1000

Here you can specify the switching threshold for enabling the trigger of trigger unit 1. Scaling: see Switching threshold 1.

**Pulse width** (R43 [▶ 62])  
default: 100

Here you can specify the pulse width ( $t_p$ ) of trigger unit 1 for the glitch mode. The number of samples ( $n_{SP}$ ) is entered as the parameter. The pulse width thus depends on the sample rate! Sample:

- Sample rate:  $T_s = 200 \mu\text{s}$   
- Samples:  $n_{SP} = 100$   
Pulse width:  $t_p = T_s \times n_{SP} = 200 \mu\text{s} \times 100 = 20 \text{ ms}$

**valid trigger time** (R44 [▶ 62])  
default:

Here you can specify the valid trigger time ( $t_{VT}$ ) for trigger unit 1. The number of valid samples ( $n_{VS}$ ) is entered as the parameter. The valid trigger time thus depends on the sample rate! Sample:

- Sample rate:  $T_s = 200 \mu\text{s}$   
- valid samples:  $n_{VS} = 100$   
Valid trigger time:  $t_{VT} = T_s \times n_{VS} = 200 \mu\text{s} \times 100 = 20 \text{ ms}$

**Timeframe active** (R40.6 [▶ 61])  
default: not activated

Here you can switch on the timeframe for trigger unit 1.

**Trigger unit 2**

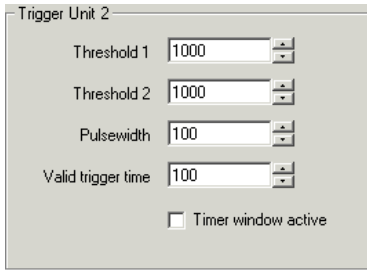

**Switching threshold 1**

(R47 [▶ 62])  
default: 1000

Here you can specify the switching threshold for the trigger source of trigger unit 2.  
Scaling: see Trigger unit 1.

**Switching threshold 2**

(R48 [▶ 62])  
default: 1000

Here you can specify the switching threshold for enabling the trigger of trigger unit 2.  
Scaling: see Trigger unit 1.

**Pulse width** (R49 [▶ 62])

default: 100

Here you can specify the pulse width for trigger unit 2.  
Scaling: see Trigger unit 1.

**valid trigger time** (R50

[▶ 62])  
default:

Here you can specify the valid trigger time for trigger unit 2.  
Scaling: see Trigger unit 1.

**Timeframe active** (R46

[▶ 62])

default: not activated

Here you can switch on the timeframe for trigger unit 2.

**Trigger unit 3 (KL3362 only)**

See Trigger unit 1.

**Trigger unit 4 (KL3362 only)**

See Trigger unit 2.

**4.5.4 Output process data**

**Output process data in detail**

**Data word 0**

Here you can choose which trigger parameter you wish to specify with data word 0 of the oscilloscope terminal for trigger unit 1.

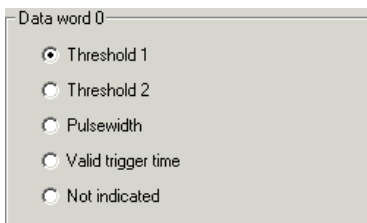

**Switching threshold 1**

**Switching threshold 2**

**Pulse width**

**Valid trigger time**

**Not indicated**

Switching threshold 1 of trigger unit 1

Switching threshold 2 of trigger unit 1

Pulse width of trigger unit 1

Valid trigger time of trigger unit 1

No parameters set

**Data word 1**

Here you can choose which trigger parameter you wish to specify with data word 1 of the oscilloscope terminal for trigger unit 1.

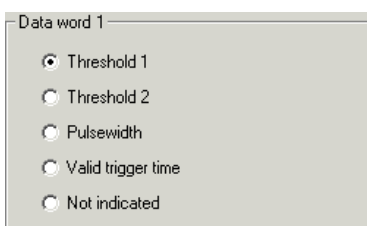

**Switching threshold 1**

**Switching threshold 2**

**Pulse width**

**Valid trigger time**

**Not indicated**

Switching threshold 1 of trigger unit 2

Switching threshold 2 of trigger unit 2

Pulse width of trigger unit 2

Valid trigger time of trigger unit 2

No parameters set

**Data word 2 (KL3362 only)**

Here you can choose which trigger parameter you wish to specify with data word 2 of the oscilloscope terminal for trigger unit 3 (see Data word 0 for trigger parameters).

**Data word 3 (KL3362 only)**

Here you can choose which trigger parameter you wish to specify with data word 3 of the oscilloscope terminal for trigger unit 3 (see Data word 1 for trigger parameters).

## 4.5.5 Input process data

### Input process data in detail

#### Data word 0

Here you can specify which input value is transferred with data word 0 from the oscilloscope terminal to the control.



Fig. 23: Selecting the input value for data word 0

Input value	Comment
Current measurement reading	Current analog value
Maximum value	Maximum value of a recording
Minimum value	Minimum value of a recording
RMS value	RMS value of a recording: $\sqrt{(\text{Sum}(x_n^2))/n}$
Mean value	Arithmetic mean of a recording: $(\text{Sum}(x_n))/n$
Peak-peak value	Peak-peak value of a recording
Cycle duration	Cycle duration of a recording
Pulse width HIGH	<ul style="list-style-type: none"> <li>four successive values have to be above the switching threshold for activating the start</li> <li>four successive values have to be below the switching threshold for activating the stop</li> </ul>
Pulse width LOW	<ul style="list-style-type: none"> <li>four successive values have to be above the switching threshold for activating the start</li> <li>four successive values have to be below the switching threshold for activating the stop</li> </ul>
Duty factor	Duty factor
Jitter $T_{max}$	reserved
Jitter $T_{min}$	reserved
Jitter $T_{mean}$	reserved
Histogram Max	Most frequent value of a recording
Read value timer 1	stored value of the <u>timer</u> [▶ 40] (chronometer) from trigger unit 1*
Current value timer 1	current value of the <u>timer</u> [▶ 40] (chronometer) from trigger unit 1*
Read value timer 2	stored value of the <u>timer</u> [▶ 40] (chronometer) from trigger unit 2**
Current value timer 2	current value of the <u>timer</u> [▶ 40] (chronometer) from trigger unit 2*
Error counter inner envelope curve	Error counter of the inner envelope curve
Error counter outer envelope curve	Error counter of the outer envelope curve
Number of samples up to analog value greater than switching threshold	Number of measurement points recorded up to the time when the analog value exceeded the switching threshold.
Number of samples up to analog value less than switching threshold	Number of measurement points recorded up to the time when the analog value was less than the switching threshold.

**Data word 1**

Here you can specify which input value is transferred with data word 1 from the oscilloscope terminal to the control.



Fig. 24: Selecting the input value for data word 1

(input values see Data word 0).

**Data word 2 (KL3362 only)**

Here you can specify which input value is transferred with data word 2 from the oscilloscope terminal to the control.



Fig. 25: Selecting the input value for data word 2 (KL3362 only)

(input values see Data word 0).

**Data word 3 (KL3362 only)**

Here you can specify which input value is transferred with data word 3 from the oscilloscope terminal to the control.



Fig. 26: Selecting the input value for data word 3 (KL3362 only)

(input values see Data word 0).

## 4.6 Sample program for KL register communication via EtherCAT on KL3314 exemplary

### **i** Using the sample programs

This document contains sample applications of our products for certain areas of application. The application notes provided here are based on typical features of our products and only serve as examples. The notes contained in this document explicitly do not refer to specific applications. The customer is therefore responsible for assessing and deciding whether the product is suitable for a particular application. We accept no responsibility for the completeness and correctness of the source code contained in this document. We reserve the right to modify the content of this document at any time and accept no responsibility for errors and missing information.

### Program description / function

This example program (TwinCAT 3) provides change of single register values of the KL3314 as selection of the element type, characteristic settings of the feature register R32 and user scaling offset and gain (R33/ R34) similar as per KS2000.

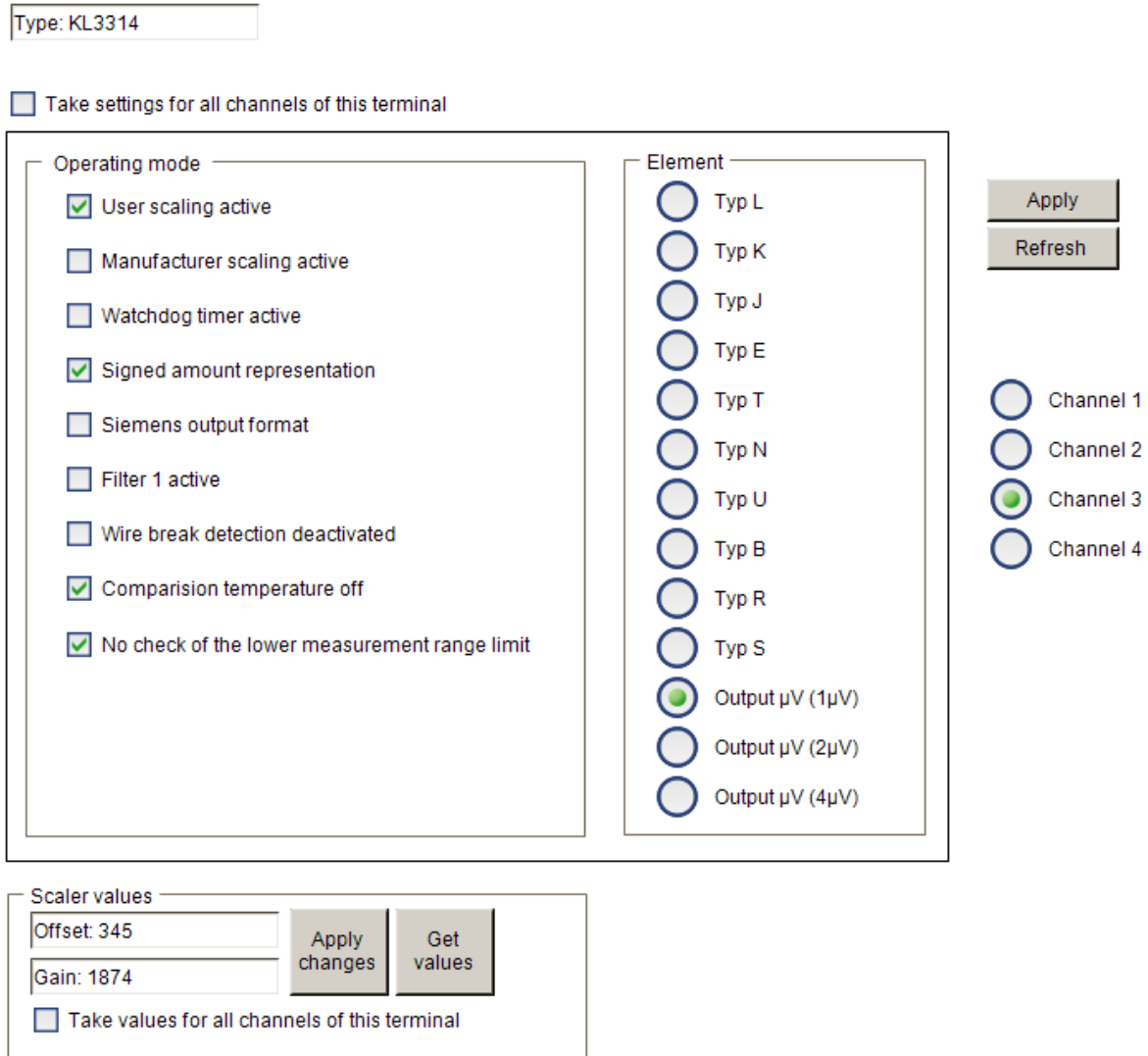



Fig. 27: Settings of KL3314 via visualisation of TwinCAT 3

At least following configuration setup shall be present:

[coupler (e.g. BK1120) or embedded PC] + KL3314 + KL9010.

 Download:  
<https://infosys.beckhoff.com/content/1033/kl336x/Resources/zip/5996114571.zip>

**Preparations for starting the sample programs (tnzip file / TwinCAT 3)**

- Click on the download button to save the Zip archive locally on your hard disk, then unzip the \*.tnzip archive file in a temporary folder.

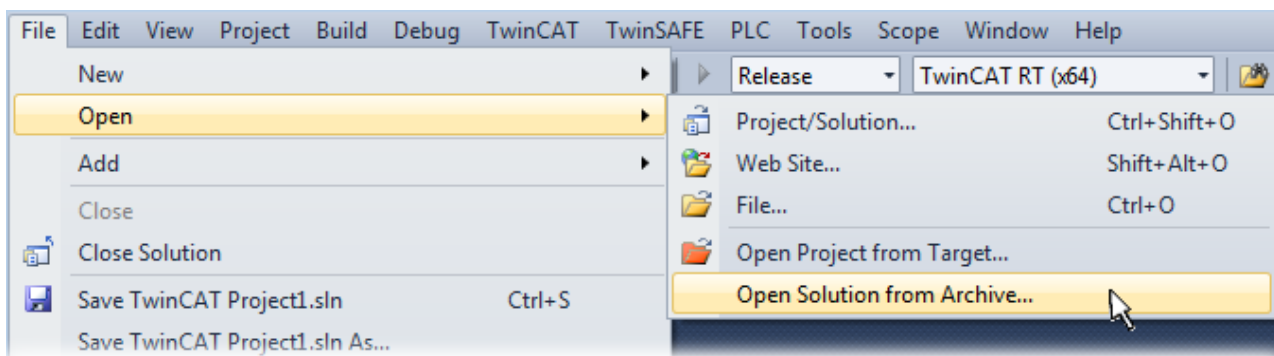

Fig. 28: Opening the \*.tnzip archive

- Select the .tnzip file (sample program).
- A further selection window opens. Select the destination directory for storing the project.
- For a description of the general PLC commissioning procedure and starting the program please refer to the terminal documentation or the EtherCAT system documentation.
- The EtherCAT device of the example should usually be declared your present system. After selection of the EtherCAT device in the “Solutionexplorer” select the “Adapter” tab and click on “Search...”:

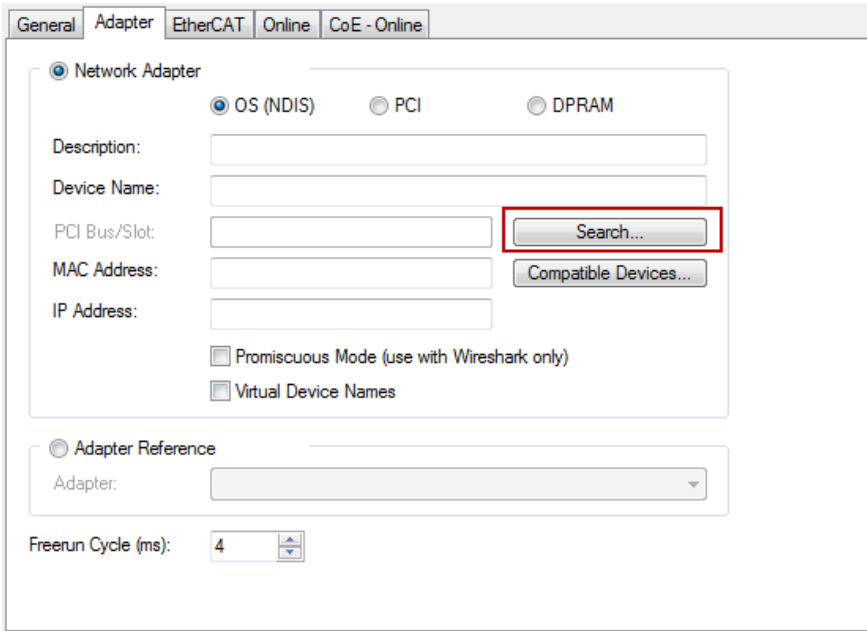
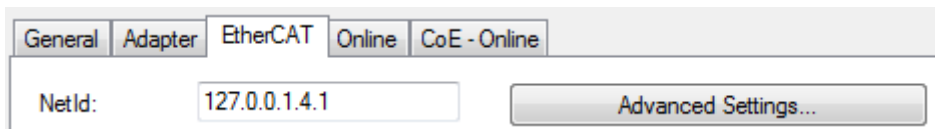

Fig. 29: Search of the existing HW configuration for the EtherCAT configuration of the example

- Checking NetId: the "EtherCAT" tab of the EtherCAT device shows the configured NetId:



The first 4 numbers have to be identical with the project NetId of the target system. The project NetId can be viewed within the TwinCAT environment above, where a pull down menu can be opened to choose a target system (by clicking right in the text field). The number blocks are placed in brackets there next to each computer name of a target system.

- Modify the NetId: By right clicking on "EtherCAT device" within the solution explorer a context menu opens where "Change NetId..." have to be selected. The first 4 numbers of the NetId of the target computer have to be entered; the both last values are 4.1 usually.

Example:

- NetId of project: myComputer (123.45.67.89.1.1)
- Entry via „Change NetId...“: 123.45.67.89.4.1

## 5 Access from the user program

The index registers [R38 \[► 60\]](#) and [R39 \[► 61\]](#) can be used to specify which process data are cyclically transferred from the oscilloscope terminal

- KL3361 with registers [DataIN11 \[► 50\]](#) and [DataIN12 \[► 50\]](#)
- KL3362 with registers [DataIN11 \[► 50\]](#) and [DataIN12 \[► 50\]](#) (channel 1) or [DataIN21 \[► 50\]](#) and [DataIN22 \[► 50\]](#) (channel 2)

to the controller. Maximum values, minimum values, RMS values, mean values, individual sampling values (sample n after trigger event), rise times, pulse widths etc. can thus optionally be represented directly in the process data.

The index register [R37 \[► 59\]](#) can be used to specify which process data are cyclically transferred to oscilloscope terminal

- KL3361 with registers [DataOUT11 \[► 50\]](#) and [DataOUT12 \[► 50\]](#)
- KL3362 with registers [DataOUT11 \[► 50\]](#) and [DataOUT12 \[► 50\]](#) (channel 1) or [DataOUT21 \[► 50\]](#) and [DataOUT22 \[► 50\]](#) (channel 2)

. Switching thresholds, pulse widths etc. can thus optionally be specified via the process data channel.

### Evaluation of a recording

A recording is requested via the *bEnableTrigger* bit. Current values are present in the memory if the *bTriggerDone* bit appears in the status byte of the terminal. If the memory is to be read or evaluated, the *bEnableTrigger* bit must remain set, otherwise the memory is continuously overwritten.

Evaluation of the memory is activated via the *bEvalBuffer* bit. Current values are present in the process data, as soon as the *bEvalBufferDone* bit appears. Multiple evaluation of the memory is thus possible. Mean value, maximum value, minimum value, RMS value of the recording can thus be read sequentially.

### Reading the trace memory

Samples can be read via the *Trace data registers* [R60 \[► 63\]](#) and [R61 \[► 63\]](#). To this end, the offset within the memory can be specified via the *Trace index register* ([R62 \[► 63\]](#)).

The *Zoom register* ([R63 \[► 63\]](#)) can be used to specify a number  $n_s$  of samples for which the maximum value, minimum value and mean value is calculated, or the sample interval  $n_s$  at which the values are output. After each read access of R60 or R61, the *Trace index register* ([R62 \[► 63\]](#)) is incremented by  $n_s$ .

Sample:

For calling up all values from the memory, enter the value 0x0000 in R62 and 0x0001 in R63. Then read R60 and R61 alternatively. If only every second value is to be read, enter the value 0x0002 in R63.

### Envelope monitoring

Each recording can be monitored with a tight or a wide interval. The tight interval is subsequently referred to as inner envelope curve, the wide interval as outer envelope curve.

Application sample:

- Monitoring of an ageing process via the inner envelope curve
- Monitoring of malfunctions via the outer envelope curve

A reference curve can be placed in the flash memory of the terminal, which is copied to the RAM after a terminal reset.

If evaluation of the inner or outer error counter is activated, i.e. if the index register for process data ([R38 \[► 60\]](#) or [R39 \[► 61\]](#)) contains the value 18 or 19, the difference between the respective actual value and the target value is compared with parameter x of the envelope curve ([R53 \[► 62\]](#), [R54 \[► 62\]](#)). If the difference is greater, the respective counter is incremented.

The RAM area can be overwritten with current trace data (Teach-in) via the command register (R7 [► 56]) using the instruction *WriteEnvCurvToRAM* (0x0201), or it can be directly written and read from offset 0x8000. The command *WriteEnvCurvToFLASH* (0x0202) can then be used to place data in the flash memory, and are retained even if the voltage supply fails.

## 5.1 Process image

### 5.1.1 Process image of the KL3361

The following 5 bytes are transferred bi-directionally between KL3361 and control:

Oscilloscope channel	Byte offset (without word alignment*)	Byte offset (with word alignment*)	Format	Input data	Output data
1	0	0	Byte	Status byte 1 (SB1)	Control byte 1 (CB1)
	1	2	Word	DataIN0	DataOUT0
	3	4	Word	DataIN1	DataOUT1

\*) Word alignment: The Bus Coupler places values on even byte addresses

Analog voltages are represented by the oscilloscope terminal KL3361 as follows:

Voltage	Decimal	Hexadecimal
+20 mV	32767	0x7FFF
0 mV	0	0x0000
-20 mV	-32767	0x8001

### 5.1.2 Process image of the KL3362

The following 10 bytes are transferred bi-directionally between KL3362 and control:

Oscilloscope channel	Byte offset (without word alignment*)	Byte offset (with word alignment*)	Format	Input data	Output data
1	0	0	Byte	Status byte 1 (SB1)	Control byte 1 (CB1)
	1	2	Word	DataIN0 (channel 1)	DataOUT0 (channel 1)
	3	4	Word	DataIN1 (channel 1)	DataOUT1 (channel 1)
2	5	8	Byte	Status byte 2 (SB2)	Control byte 2 (CB2)
	6	10	Word	DataIN0 (channel 2)	DataOUT0 (channel 2)
	8	12	Word	DataIN1 (channel 2)	DataOUT1 (channel 2)

\*) Word alignment: The Bus Coupler places values on even byte addresses

Analog voltages are represented by the oscilloscope terminal KL3362 as follows:

Voltage	Decimal	Hexadecimal
+10 V	32767	0x7FFF
0 V	0	0x0000
-10 V	-32767	0x8001

## 5.1.3 Control and status bytes

### 5.1.3.1 First channel

#### 5.1.3.1.1 Process data mode

##### Control byte 1 (CB1) in process data mode

The control byte of the first channel can be found in the output image of the oscilloscope terminal and is transferred from the controller to the terminal.

Bit	CB1.7	CB1.6	CB1.5	CB1.4	CB1.3	CB1.2	CB1.1	CB1.0
Name	bRegAccess	-	-	-	bSetDigitalOut	bEnabIntFkt	bEvalBuffer	bEnableTrigger

Legend			
Bit	Name	Description	
CB1.7	bRegAccess	0 <sub>bin</sub>	Register communication off (process data mode): <ul style="list-style-type: none"> <li>Process data word <a href="#">DataIN0 [► 50]</a> is used to transfer the date specified with index register 1 for input data (<a href="#">R38 [► 60]</a>)* from the terminal to the control.</li> <li>Process data word <a href="#">DataIN1 [► 50]</a> is used to transfer the date specified with index register 2 for input data (<a href="#">R39 [► 61]</a>)* from the terminal to the control.</li> <li>Process data word <a href="#">DataOUT0 [► 50]</a> is used to transfer the parameter specified with the Low byte of the index register for output data (<a href="#">R37 [► 59]</a>)* from the control to the terminal.</li> <li>Process data word <a href="#">DataOUT1 [► 50]</a> is used to transfer the parameter specified with the High byte of the index register for output data (<a href="#">R37 [► 59]</a>)* from the control to the terminal.</li> </ul> *) These registers can be set via the register communication or with the <a href="#">KS2000 [► 28]</a> configuration software.
CB1.6	-		reserved
CB1.5	-		reserved
CB1.4	-		reserved
CB1.3	bSetDigitalOut		Setting the digital output.
CB1.2	bEnabIntFkt		Enabling direct setting of the digital output through the trigger unit:
		0 <sub>bin</sub>	The trigger unit must not set the digital output when triggered (default).
		1 <sub>bin</sub>	The trigger unit may set the digital output directly when triggered ( <a href="#">SET DOUT [► 39]</a> ).
CB1.1	bEvalBuffer		The recorded memory is to be evaluated.
CB1.0	bEnableTrigger		The rising edge of this bit activates the trigger in trigger mode <a href="#">Shot [► 39]</a> .

##### Status byte 1 (SB1) in process data mode

The status byte of the first channel can be found in the input image of the oscilloscope terminal and is transferred from the terminal to the controller.

Bit	SB1.7	SB1.6	SB1.5	SB1.4	SB1.3	SB1.2	SB1.1	SB1.0
Name	bRegAccessQ	bError	-	-	bDigitalOutputStatus	bExtTriggerInput	bEvalBufferDone	bTriggerDone

Legend			
Bit	Name	Description	
SB1.7	bRegAccessQ	0 <sub>bin</sub>	Process data mode acknowledgement
SB1.6	bError	0 <sub>bin</sub>	No error
		1 <sub>bin</sub>	An error has occurred
SB1.5	-		reserved
SB1.4	-		reserved
SB1.3	bDigitalOutputStatus		State of the digital output
SB1.2	bExtTriggerInput		State of the trigger input
SB1.1	bEvalBufferDone		Evaluation of the memory is complete. There are valid current process data present.
SB1.0	bTriggerDone		Acknowledgement for trigger event, values were recorded.

### 5.1.3.1.2 Register communication

#### Control byte 1 (CB1) in register communication

The control byte of the first channel can be found in the output image of the oscilloscope terminal and is transferred from the controller to the terminal.

Bit	CB1.7	CB1.6	CB1.5	CB1.4	CB1.3	CB1.2	CB1.1	CB1.0
Name	bRegAccess	R/W	Register number					

Legend			
Bit	Name	Description	
CB1.7	bRegAccess	1 <sub>bin</sub>	Register communication switched on.
CB1.6	R/W	0 <sub>bin</sub>	Read access: <ul style="list-style-type: none"> <li>The process data word <a href="#">DataIN0 [► 50]</a> is used to read the register specified with the register number (CB1.5-CB1.0).</li> <li>The process data word <a href="#">DataIN1 [► 50]</a> is not used for register communication and is not available for process data during register communication. <a href="#">See note below! [► 52]</a></li> </ul>
		1 <sub>bin</sub>	Write access: <ul style="list-style-type: none"> <li>The process data word <a href="#">DataOUT0 [► 50]</a> is used to write the register specified with the register number (CB1.5-CB1.0).</li> <li>The process data word <a href="#">DataOUT1 [► 50]</a> is not used for register communication and is not available for process data during register communication.</li> </ul>
CB1.5- CB1.0	Register number	Number of the register that is to be read or written.	

#### ⚠ CAUTION

#### Invalid process data!

Process data that may still be displayed is not valid!

#### Status byte 1 (SB1) in register communication

The status byte of the first channel can be found in the input image of the oscilloscope terminal and is transferred from the terminal to the controller.

Bit	SB1.7	SB1.6	SB1.5	SB1.4	SB1.3	SB1.2	SB1.1	SB1.0
Name	bRegAccessQ	R	Register number					

Legend			
Bit	Name	Description	
SB1.7	bRegAccessQ	1 <sub>bin</sub>	Register access acknowledgement
SB1.6	R	0 <sub>bin</sub>	Read access
SB1.5- SB1.0	Register number	Number of the register that was read or written.	

### 5.1.3.2 Second channel (KL3362 only)

#### 5.1.3.2.1 Process data mode

##### Control byte 2 (CB2) in process data mode

The control byte of the second channel currently has no function in process data mode.

Bit	SB2.7	SB2.6	SB2.5	SB2.4	SB2.3	SB2.2	SB2.1	SB2.0
Name	bRegAccess	-	-	-	-	-	-	-

Legend			
Bit	Name	Description	
SB2.7	bRegAccess	0 <sub>bin</sub>	Register communication off (process data mode)
SB2.6- SB2.0	-	reserved	

##### Status byte 2 (SB2) in process data mode

The status byte of the second channel currently has no function in process data mode.

Bit	SB2.7	SB2.6	SB2.5	SB2.4	SB2.3	SB2.2	SB2.1	SB2.0
Name	bRegAccessQ	-	-	-	-	-	-	-

Legend			
Bit	Name	Description	
SB2.7	bRegAccessQ	0 <sub>bin</sub>	Process data mode acknowledgement
SB2.6- SB2.0	-	reserved	

#### 5.1.3.2.2 Register communication

##### Control byte 2 (CB2) in register communication

The control byte of the second channel can be found in the output image of the oscilloscope terminal and is transferred from the controller to the terminal.

Bit	CB2.7	CB2.6	CB2.5	CB2.4	CB2.3	CB2.2	CB2.1	CB2.0
Name	bRegAccess	R/W	Register number					

Legend			
Bit	Name	Description	
CB2.7	bRegAccess	1 <sub>bin</sub>	Register communication switched on.
CB2.6	R/W	0 <sub>bin</sub>	Read access: <ul style="list-style-type: none"> <li>The process data word <a href="#">DataIN2 [► 50]</a> is used to read the register specified with the register number (CB2.5-CB2.0).</li> <li>The process data word <a href="#">DataIN3 [► 50]</a> is not used for register communication and is not available for process data during register communication. <a href="#">See note [► 54]!</a></li> </ul>
		1 <sub>bin</sub>	Write access: <ul style="list-style-type: none"> <li>The process data word <a href="#">DataOUT2 [► 50]</a> is used to write the register specified with the register number (CB2.5-CB2.0).</li> <li>The process data word <a href="#">DataOUT3 [► 50]</a> is not used for register communication and is not available for process data during register communication.</li> </ul>
CB2.5- CB2.0	Register number	Number of the register that is to be read or written.	

**⚠ CAUTION****Invalid process data!**

Process data that may still be displayed is not valid!

**Status byte 2 (SB2) in register communication**

The status byte of the second channel can be found in the input image of the oscilloscope terminal and is transferred from the terminal to the controller.

Bit	SB2.7	SB2.6	SB2.5	SB2.4	SB2.3	SB2.2	SB2.1	SB2.0
Name	bRegAccessQ	R	Register number					

Legend			
Bit	Name	Description	
SB2.7	bRegAccessQ	1 <sub>pin</sub>	Register access acknowledgement
SB2.6	R	0 <sub>pin</sub>	Read access
SB2.5- SB2.0	Register number	Number of the register that was read or written.	

## 5.2 RAM and ROM register

### 5.2.1 Register overview

The following registers exist for each signal channel of the oscilloscope terminal. This means these registers exist

- once on the KL3601.
- twice on the KL3602.

Register	Comment	Default value		R/W	Memory
R0 <a href="#">[▶ 56]</a>	Raw value of the A/D converter	-	-	R	RAM
R1 - R5	reserved	0x0000	0 <sub>dec</sub>	R	RAM
R6 <a href="#">[▶ 56]</a>	Diagnostic register	-	-	R	RAM
R7 <a href="#">[▶ 56]</a>	Command register	0x0000	0 <sub>dec</sub>	R/W	RAM
R8 <a href="#">[▶ 56]</a>	Terminal description	KL3361: 0x0D21 KL3362: 0x0D22	KL3361: 3361 <sub>dec</sub> KL3362: 3362 <sub>dec</sub>	R	ROM
R9 <a href="#">[▶ 57]</a>	Firmware version	e.g. 0x3143	e.g. 12611 <sub>dec</sub>	R	ROM
R10 <a href="#">[▶ 57]</a>	Multiplex shift register	KL3361: 0x0128 KL3362: 0x0228	KL3361: 296 <sub>dec</sub> KL3362: 552 <sub>dec</sub>	R	ROM
R11 <a href="#">[▶ 57]</a>	Signal channels	KL3362: 0x0128 KL3362: 0x0228	KL3361: 296 <sub>dec</sub> KL3362: 552 <sub>dec</sub>	R	ROM
R12 <a href="#">[▶ 57]</a>	Minimum data length	0x2828	10280 <sub>dec</sub>	R	ROM
R13 <a href="#">[▶ 57]</a>	Data structure	0x0004	4 <sub>dec</sub>	R	ROM
R14	reserved	0x0000	0 <sub>dec</sub>	R	ROM
R15 <a href="#">[▶ 57]</a>	Alignment register	-	-	R/W	RAM
R16 <a href="#">[▶ 57]</a>	Hardware version number	e.g. 0x0000	e.g. 0 <sub>dec</sub>	R/W	SEEROM/RAM
R17	Hardware compensation: Offset	typically 0x1FFF	typically 8191 <sub>dec</sub>	R/W	SEEROM/RAM
R18	Hardware compensation: Gain	typically 0x1000	typically 4096 <sub>dec</sub>	R/W	SEEROM/RAM
R19	Manufacturer scaling: Offset	typically 0x0000	typically 0 <sub>dec</sub>	R/W	SEEROM/RAM
R20	Manufacturer scaling: Gain	typically 0x0100	typically 256 <sub>dec</sub>	R/W	SEEROM/RAM
R21 - R30	reserved	-	-	R/W	SEEROM/RAM
R31 <a href="#">[▶ 57]</a>	Code word register	0x0000	0 <sub>dec</sub>	R/W	RAM
R32 <a href="#">[▶ 58]</a>	Feature register	0x0000	0 <sub>dec</sub>	R/W	SEEROM/RAM
R33 <a href="#">[▶ 58]</a>	User offset	0x0000	0 <sub>dec</sub>	R/W	SEEROM/RAM
R34 <a href="#">[▶ 58]</a>	User gain	0x0100	256 <sub>dec</sub>	R/W	SEEROM/RAM
R35 <a href="#">[▶ 58]</a>	Sample rate	0x00C8	200 <sub>dec</sub>	R/W	SEEROM/RAM
R36 <a href="#">[▶ 59]</a>	Sample amount	0x0064	100 <sub>dec</sub>	R/W	SEEROM/RAM
R37 <a href="#">[▶ 59]</a>	Index register for output data	0x0000	0 <sub>dec</sub>	R/W	SEEROM/RAM
R38 <a href="#">[▶ 60]</a>	Index register 1 for input data	0x0000	0 <sub>dec</sub>	R/W	SEEROM/RAM
R39 <a href="#">[▶ 61]</a>	Index register 2 for input data	0x8010	32784 <sub>dec</sub>	R/W	SEEROM/RAM
R40 <a href="#">[▶ 61]</a>	Trigger unit 1, trigger logic	0x0D21	3361 <sub>dec</sub>	R/W	SEEROM/RAM
R41 <a href="#">[▶ 61]</a>	Trigger unit 1, threshold value 1	0x03E8	1000 <sub>dec</sub>	R/W	SEEROM/RAM
R42 <a href="#">[▶ 62]</a>	Trigger unit 1, threshold value 2	0x03E8	1000 <sub>dec</sub>	R/W	SEEROM/RAM
R43 <a href="#">[▶ 62]</a>	Trigger unit 1, pulse width	0x0064	100 <sub>dec</sub>	R/W	SEEROM/RAM
R44 <a href="#">[▶ 62]</a>	Trigger unit 1, valid trigger time	0x0064	100 <sub>dec</sub>	R/W	SEEROM/RAM
R45	reserved	-	-	R/W	SEEROM/RAM
R46 <a href="#">[▶ 62]</a>	Trigger unit 2, trigger logic	0x0D21	3361 <sub>dec</sub>	R/W	SEEROM/RAM
R47 <a href="#">[▶ 62]</a>	Trigger unit 2, threshold value 1	0x03E8	1000 <sub>dec</sub>	R/W	SEEROM/RAM
R48 <a href="#">[▶ 62]</a>	Trigger unit 2, threshold value 2	0x03E8	1000 <sub>dec</sub>	R/W	SEEROM/RAM
R49 <a href="#">[▶ 62]</a>	Trigger unit 2, pulse width	0x0064	100 <sub>dec</sub>	R/W	SEEROM/RAM
R50 <a href="#">[▶ 62]</a>	Trigger unit 2, valid trigger time	0x0064	100 <sub>dec</sub>	R/W	SEEROM/RAM
R51	reserved	-	-	R/W	SEEROM/RAM
R52 <a href="#">[▶ 62]</a>	Trigger delay	0x0000	0 <sub>dec</sub>	R/W	SEEROM/RAM
R53 <a href="#">[▶ 62]</a>	Parameter 1 envelope curve	0x0000	0 <sub>dec</sub>	R/W	SEEROM/RAM

Register	Comment	Default value		R/W	Memory
R54 [▶ 62]	Parameter 2 envelope curve	0x0000	0 <sub>dec</sub>	R/W	SEEROM/RAM
R55 [▶ 63]	Samples envelope curve	0x0000	0 <sub>dec</sub>	R/W	SEEROM/RAM
R56 [▶ 63]	Trigger frequency	0x0000	0 <sub>dec</sub>	R/W	SEEROM/RAM
R57 - R59	reserved	-	-	R/W	SEEROM/RAM
R60 [▶ 63]	Trace data register 1	0x0000	0 <sub>dec</sub>	R/W	RAM
R61 [▶ 63]	Trace data register 2	0x0000	0 <sub>dec</sub>	R/W	RAM
R62 [▶ 63]	Trace index register	0x0000	0 <sub>dec</sub>	R/W	RAM
R63 [▶ 63]	Zoom register	0x0000	0 <sub>dec</sub>	R/W	RAM

## 5.2.2 Register description

The following registers exist for each signal channel of the oscilloscope terminal. This means these registers exist

- once on the single-channel KL3361;
- twice on the two-channel KL3362.

### R0: Raw ADC value

Raw value of the analog/digital converter.

### R6: Diagnostic register

In a later firmware version, the diagnostic register will be used to provide diagnostic information about the state of the oscilloscope terminal.

### R7: Command register

This register can be used to transfer commands to the oscilloscope terminal.

### Commands

#### Command 0x0201: WriteEnvCurvToRAM

Writes the sampling values into the RAM envelope curve (Teach-in method).  
Return value: 0x201

#### Command 0x0202: WriteEnvCurvToFLASH

Writes the sampling values into the RAM envelope curve and the flash envelope curve (Teach-in method).  
Return value: 0x202

### ROM register

The terminal uses two channels for assigning a byte/word/word data structure. This structure is not supported by couplers that do not have the BK200 switch functionality. In this case, read access to the second register set is not available.

The terminal always reports with a shift register length of 5 bytes (see general terminal documentation).

### R8: Terminal description

Register R8 contains the terminal identifier in hexadecimal coding:

KL3361: 0x0D21 (3361<sub>dec</sub>)

KL3362: 0x0D22 (3362<sub>dec</sub>)

**R9: Firmware version**

Register R9 contains the firmware revision level of the terminal in hexadecimal coding, e. g. 0x3144 (12612<sub>dec</sub>).

**R10: Shift register length**

KL3361: 0x0128  
KL3362: 0x0228

**R11: Number of signal channels**

KL3361: 0x0128  
KL3362: 0x0228

**R12: Minimum data length**

KL3361: 0x2828  
KL3362: 0x2828

**R13: Data type**

Register R13 contains the data type of the Bus Terminal. 0x0004 means analog input.

**R15: Alignment register****R16: Hardware version number**

Register R16 contains the hardware revision level of the terminal in hexadecimal coding, e.g. 0x0000 (0<sub>dec</sub>).

**User register**

The user registers of the oscilloscope terminal can be written by the user program in order to change the characteristics of the oscilloscope terminal at run-time.

**R31: Code word register**

- If you write values into the user registers without previously having entered the user code word (0x1235) in the code word register, these values are only stored in the RAM registers, but not in the EPROM registers and are therefore lost if the terminal is restarted.
- If you write values into the user registers and have previously entered the user code word (0x1235) in the code word register, these values are stored in the RAM registers and in the EPROM registers and are therefore retained if the terminal is restarted.

The code word is reset if the terminal is restarted.

**R32: Feature register**

The feature register specifies the terminal's operating mode.

Bit	Operation mode	Value	Explanation	Default
R32.15	-	-	reserved	0 <sub>bin</sub>
...	-	-	reserved	0 <sub>bin</sub>
R32.11	-	-	reserved	0 <sub>bin</sub>
R32.10 R32.9 R32.8	Trigger type	000 <sub>bin</sub>	Post-trigger. Recording commences as soon as a trigger event occurs.	000 <sub>bin</sub>
		001 <sub>bin</sub>	Pre-trigger. Recording ceases as soon as a trigger event occurs.	
		010 <sub>bin</sub>	Mid-trigger: The trigger event is the center of the recording.	
		011 <sub>bin</sub>	FastSampling (from firmware version 1B'): Operation with increased sampling rate of up to 10 µs. <ul style="list-style-type: none"> <li>The recording can only be started via the trigger input.</li> <li>The settings of the trigger units are not taken into account.</li> <li>Only the first channel is recorded, even for KL3362.</li> </ul>	
R32.7	-	-	reserved	0 <sub>bin</sub>
R32.6	<a href="#">Auto trigger [► 41]</a>	0 <sub>bin</sub>	not active	0 <sub>bin</sub>
		1 <sub>bin</sub>	active: The trigger unit is automatically activated once the preceding event has been evaluated. To this end, bit 0 is toggled in status byte 1 (SB1) with each new evaluation.	
R32.5	<a href="#">Test mode [► 41]</a>	0 <sub>bin</sub>	not active	0 <sub>bin</sub>
		1 <sub>bin</sub>	active: The oscilloscope terminal simulates a ramp of sampling values. The sampling value is incremented after each reading. The ramp thus runs from 0x0000 to 0x3FFF. From 0x3FFF, the sampling value after each reading is decremented, so that the ramp returns to 0x0000. The process is repeated cyclically.	
R32.4	<a href="#">Trigger delay [► 41]</a>	0 <sub>bin</sub>	not active	0 <sub>bin</sub>
		1 <sub>bin</sub>	active: Samples skipped after the trigger event. The number of samples that are skipped is specified in the <i>Trigger delay</i> register ( <a href="#">R52 [► 62]</a> ).	
R32.3	-	-	reserved	0 <sub>bin</sub>
...	-	-	reserved	0 <sub>bin</sub>
R32.0	-	-	reserved	0 <sub>bin</sub>

**R33: User offset**

Offset, can be changed by the user. Scaling:  
offset = full scale value x parameter / resolution

Sample for KL3361: 16 mV x 100 / 32767 = 0,049 mV

**R34: User gain**

Gain factor, can be changed by the user.

**R35: Sample rate**

Interval ( $T_s$ ) between two samples (scans) in microseconds.

The sampling speed is limited to  $T_s = 100 \mu s$  (10 kHz) by the evaluation of the trigger detectors.

Only the [Fast sampling \[► 41\]](#) mode enables sampling at  $T_s = 10 \mu s$  (100 kHz).

**i Data transfer rate on the K-bus**

The sample rate influences the transmission speed with which the oscilloscope terminal can be addressed by the K-Bus.

This must be taken into account when considering your PLC cycle time:

- A sample rate of 100 µs can only accommodate bus cycles with a minimum duration of 3 ms!
- A sample rate of 150 µs can only accommodate bus cycles with a minimum duration of 2 ms!
- The [Fast sampling \[▶ 41\]](#) mode can only accommodate K-bus cycles with a minimum duration of 2 ms!

**R36: Sample amount**

Number of sampling values to be recorded. A maximum of 4,000 values can be recorded (default 100).

**R37: Index register for output data (terminal parameters)**

• **Low byte:**

The content of the Low byte of this register determines which parameter of the oscilloscope terminal

- KL3361 is assigned process data register [DataOUT0 \[▶ 50\]](#)
- KL3362 is assigned process data register [DataOUT0 \(channel 1\) \[▶ 50\]](#) or process data register [DataOUT0 \(channel 2\) \[▶ 50\]](#)

is described. The decimal value of the indices corresponds to the register number of the parameter to be written.

The following indices are supported:

Index	Decimal	Parameter
0x00	00	Default value
0x29	<a href="#">41 [▶ 61]</a>	Trigger unit 1, switching threshold 1
0x2A	<a href="#">42 [▶ 62]</a>	Trigger unit 1, switching threshold 2
0x2B	<a href="#">43 [▶ 62]</a>	Trigger unit 1, pulse width
0x2C	<a href="#">44 [▶ 62]</a>	Trigger unit 1, valid trigger time
0x2F	<a href="#">47 [▶ 62]</a>	Trigger unit 2, switching threshold 1
0x30	<a href="#">48 [▶ 62]</a>	Trigger unit 2, switching threshold 2
0x31	<a href="#">49 [▶ 62]</a>	Trigger unit 2, pulse width
0x32	<a href="#">50 [▶ 62]</a>	Trigger unit 2, valid trigger time

• **High byte:**

The content of the High byte of this register determines which parameter of the oscilloscope terminal

- KL3361 is assigned process data register [DataOUT1 \[▶ 50\]](#)
- KL3362 is assigned process data register [DataOUT1 \(channel 1\) \[▶ 50\]](#) or process data register [DataOUT1 \(channel 2\) \[▶ 50\]](#)

is described (see [Low byte \[▶ 59\]](#) for indices).

**R38: Index register 1 for input data**

The content of this register (default value: 0x0000) determines which data is shown in the process data register

- DataIN0 [► 50] of oscilloscope terminal KL3361
- DataIN0 (channel 1) [► 50] or DataIN0 (channel 2) [► 50] of oscilloscope terminal KL3362

The following indices are supported:

Index	Decimal	Date
0x0000	0	Current analog value
0x0001	1	Maximum value of a recording
0x0002	2	Minimum value of a recording
0x0003	3	RMS value of the recording: $\text{Sqrt}((\text{Sum } (x_n^2))/n)$
0x0004	4	Mean value of the recording: $(\text{Sum } (x_n))/n$
0x0005	5	Peak-peak value of the recording
0x0006	6	Cycle duration
0x0007	7	Pulse width - high: switching threshold is trigger level 1 <ul style="list-style-type: none"> <li>• The trigger starts as soon as four successive values are above the switching threshold</li> <li>• The trigger is stopped as soon as four successive values are below the switching threshold</li> </ul>
0x0008	8	Pulse width - low: switching threshold is trigger level 1 <ul style="list-style-type: none"> <li>• The trigger starts as soon as four successive values are below the switching threshold</li> <li>• The trigger is stopped as soon as four successive values are above the switching threshold</li> </ul>
0x0009	9	Duty factor
0x000A	10	reserved for jitter $T_{\max}$
0x000B	11	reserved for jitter $T_{\min}$
0x000C	12	reserved for jitter $T_{\text{mean}}$
0x000D	13	Histogram max, i.e. the value that has occurred most frequently.
0x000E	14	Timer1LatchValue
0x000F	15	Timer1Run (read/write)
0x0010	16	Timer2LatchValue
0x0011	17	Timer2Run (read/write)
0x0012	18	Error counter inner envelope curve
0x0013	19	Error counter outer envelope curve
0x0014	20	Number of samples up to analog value greater than switching threshold 1
0x0015	21	Number of samples up to analog value less than switching threshold 1
0x8000		First sampling value. The recorded sampling values are available from here. The MSB has to be set to zero in order to determine the trace offset.
0x8001		Second sampling value.
0x8002		Third sampling value.
...	...	...
0x8063		Hundredth sampling value (in the delivery state, 100 values are stored).
...	...	...
0x8F9F		Four thousandth sampling value (a maximum of 4,000 values can be stored).

**R39: Index register 2 for input data**

The content of this register (default value: 0x8010) determines which data is shown in the process data register

- [DataIN1 \[► 50\]](#) of oscilloscope terminal KL3361
- [DataIN1 \(channel 1\) \[► 50\]](#) or [DataIN1 \(channel 2\) \[► 50\]](#) of oscilloscope terminal KL3362

(see [Index register 1 for process input data \[► 60\]](#) for indices).

**R40: Trigger unit 1, trigger logic**

Bit	Operation mode	Value	Explanation	Default	
R40.15	-	-	reserved	0 <sub>bin</sub>	
R40.14, R40.13, R40.12	enableSource	000 <sub>bin</sub>	Trigger always enabled	000 <sub>bin</sub>	
		001 <sub>bin</sub>	Trigger activated, if signal at analog input 1 above <a href="#">switching threshold 2 [► 62]</a>		Analog input 1 is in <ul style="list-style-type: none"> <li>• KL3361: the input for differential voltage of the measuring bridge in KL3361 (<a href="#">UB+/UB- [► 23]</a>)</li> <li>• KL3362: oscilloscope input channel 1 (<a href="#">IN 1 [► 25]</a>)</li> </ul>
		010 <sub>bin</sub>	Trigger activated, if signal at analog input 1 below <a href="#">switching threshold 2 [► 62]</a>		
		011 <sub>bin</sub>	Trigger activated, if signal at analog input 2 above <a href="#">switching threshold 2 [► 62]</a>		Analog input 2 is in <ul style="list-style-type: none"> <li>• KL3361 not available</li> <li>• KL3362: oscilloscope input channel 2 (<a href="#">IN 2 [► 25]</a>)</li> </ul>
		100 <sub>bin</sub>	Trigger activated, if signal at analog input 1 below <a href="#">switching threshold 2 [► 62]</a>		
		101 <sub>bin</sub>	Trigger enabled if trigger input (24 V trigger) on high potential.		
110 <sub>bin</sub>	Trigger enabled if trigger input (24 V trigger) on low potential.				
R40.11, R40.10	TriggerSource	00 <sub>bin</sub>	Timer with switching threshold 1	11 <sub>bin</sub>	
		01 <sub>bin</sub>	first analog input (IN1), with <a href="#">switching threshold 1 [► 61]</a>		
		10 <sub>bin</sub>	second analog input (IN2), with <a href="#">switching threshold 1 [► 61]</a> (KL3362 only)		
		11 <sub>bin</sub>	Digital input		
R40.9, R40.8	Trigger mode	00 <sub>bin</sub>	Shot: The trigger is activated with an edge of bit <i>bEnableTrigger</i> of control byte 1 (CB1.0), if enableSource is set.	01 <sub>bin</sub>	
		01 <sub>bin</sub>	Edge: The trigger is triggered via the edge selected via TriggerSource and bLogic, if it is enabled via enableSource.		
		10 <sub>bin</sub>	Glitch: The trigger is triggered via the pulse selected via TriggerSource, bLogic and bLarger, if it is enabled via enableSource.		
R40.7	-	-	reserved	0 <sub>bin</sub>	
R40.6	bTriggerWinEn	1 <sub>bin</sub>	The trigger condition for the following trigger unit must arrive within the <a href="#">valid trigger time for trigger unit 1 [► 42]</a> . Otherwise everything is reset	0 <sub>bin</sub>	
R40.5	bStartScopeRec	0 <sub>bin</sub>	The trigger event causes the downstream trigger unit to be enabled	0 <sub>bin</sub>	
		1 <sub>bin</sub>	The trigger event causes the recording to be started		
R40.4	bTriggerOutEn	1 <sub>bin</sub>	The trigger event causes the digital output to be set, if this is enabled through bit 2 of control byte 1 (CB1.2).	0 <sub>bin</sub>	
R40.3	bLatchtimer	1 <sub>bin</sub>	The trigger event causes the current value of the running timer to be stored.	0 <sub>bin</sub>	
R40.2	bResetTimer	1 <sub>bin</sub>	The trigger event causes the timer to be reset to zero. The timer will start running again automatically immediately.	0 <sub>bin</sub>	
R40.1	bLarger	0 <sub>bin</sub>	in glitch mode: pulse width less than <a href="#">the pulse width [► 62]</a> specified for <a href="#">trigger unit 1 [► 62]</a>	0 <sub>bin</sub>	
		1 <sub>bin</sub>	in glitch mode: pulse width greater than <a href="#">the pulse width [► 62]</a> specified for <a href="#">trigger unit 1 [► 62]</a>		
R40.0	bLogic	0 <sub>bin</sub>	in edge mode (edge triggering): falling edge	in glitch mode: negative pulse	
		1 <sub>bin</sub>	in edge mode (edge triggering): rising edge	in glitch mode: positive pulse	

**R41: Trigger unit 1, switching threshold 1**

Switching threshold for the [trigger source \[► 42\]](#) of trigger unit 1

**R42: Trigger unit 1, switching threshold 2**

Switching threshold for enabling the trigger [[▶ 42](#)] (EnableSource) of trigger unit 1

**R43: Trigger unit 1, pulse width**

Here you can specify the pulse width [[▶ 42](#)] ( $t_p$ ) of trigger unit 1 for the glitch mode. The number of samples ( $n_{SP}$ ) is entered as the parameter. The pulse width thus depends on the sample rate! Sample:

- Sample rate:  $T_s = 200 \mu s$
- Samples:  $n_{SP} = 100$

Pulse width:  $t_p = T_s \times n_{SP} = 200 \mu s \times 100 = 20 \text{ ms}$

**R44: Trigger unit 1, valid trigger time**

Here you can specify the valid trigger time [[▶ 42](#)] ( $t_{VT}$ ) for trigger unit 1. The number of valid samples ( $n_{VS}$ ) is entered as the parameter. The valid trigger time thus depends on the sample rate! Sample:

- Sample rate:  $T_s = 200 \mu s$
- Valid samples:  $n_{VS} = 100$

Valid Trigger Time:  $t_{VT} = T_s \times n_{VS} = 200 \mu s \times 100 = 20 \text{ ms}$

**R46: Trigger unit 2, trigger logic**

see Trigger detector 1 [[▶ 61](#)]

**R47: Trigger unit 2, switching threshold 1**

Switching threshold for the trigger source (TriggerSource) of trigger unit 2

**R48: Trigger unit 2, switching threshold 2**

Switching threshold for enabling the trigger (EnableSource) of trigger unit 2

**R49: Trigger unit 2, pulse width**

Here you can specify the pulse width ( $t_p$ ) of trigger unit 2 for the glitch mode (see Trigger unit 1, pulse width [[▶ 62](#)]).

**R50: Trigger unit 2, valid trigger time**

see Trigger unit 1, valid trigger time [[▶ 62](#)]

**R52: Trigger delay**

A trigger delay [[▶ 41](#)] ( $t_{TD}$ ) can be specified here. The number of skipped samples ( $n_{STD}$ ) is entered as the parameter. The trigger delay thus depends on the sample rate! Sample: - Sample Rate:  $T_s = 200 \mu s$ , - Skipped Samples:  $n_{STD} = 100$

$t_{TD} = T_s \times n_{STD} = 200 \mu s \times 100 = 20 \text{ ms}$

**R53: Parameter 1 envelope curve**

e.g. distance of the inner envelope curve  
After the trace recording, the envelope curve is evaluated.

**R54: Parameter 2 envelope curve**

e.g. distance of the outer envelope curve  
After the trace recording, the envelope curve is evaluated.

**R55: Samples envelope curve**

Number of samples to be evaluated (512 max.).

**R56: Trigger frequency**

Frequency of the [timer \[▶ 39\]](#) that can be used for triggering.

**R60: Trace data register 1**

Contains the sampling value from the register specified in the trace index register (R62).  
After the end of the read access (change of register address), the trace index (R62) is incremented by the zoom distance  $n_z$  (see [R63 \[▶ 63\]](#)).

**R61: Trace data register 2**

Contains the sampling value from the register following the register specified in the trace index register (R62).  
After the end of the read access (change of register address), the trace index (R62) is incremented by the zoom distance  $n_z$  (see [R63 \[▶ 63\]](#)).

**R62: Trace index register**

Writing: Sets the trace index to offset  
Reading: Current value of the trace index.

The index is reset to zero at the start of a recording.  
Offset zero to 0x3FFF contains the trace data.  
From 0x8000, the envelope curve is given

**R63: Zoom register**

With the zoom register you can specify that

- only certain values or
- pre-processed values (maximum value , minimum value or arithmetic mean value)

are transferred to the control.

Bit	Name	Value	Explanation	Default
R63.15 R63.14	Zoom mode	00 <sub>bin</sub>	Sample zoom - the trace index register is increased automatically after each reading by the zoom distance $n_z$ . Therefore, only every $n_z$ th value is read.	-
		01 <sub>bin</sub>	Max zoom - the highest of the read values is output	
		10 <sub>bin</sub>	Min zoom - the lowest of the read values is output	
		11 <sub>bin</sub>	Mean value zoom - the arithmetic mean of the read values is output	
R63.13 R63.12	-	-	reserved	-
R63.11 ... R63.0	Zoom distance $n_z$		Number $n_z$ of sampling values, by which the trace index register ( <a href="#">R62 [▶ 63]</a> ) is increased in zoom mode <i>Sample zoom</i> after each reading. Samples:	-
		0x000	The same value is always read.	
		0x001	All values are read.	
		0x002	Only every second value is read.	
		0x00A	Only every tenth value is read.	

## 5.2.3 Examples of Register Communication

The numbering of the bytes in the examples corresponds to the display without word alignment.

### 5.2.3.1 Example 1: reading the firmware version from Register 9

#### Output Data

Byte 0: Control byte	Byte 1: DataOUT1, high byte	Byte 2: DataOUT1, low byte
0x89 (1000 1001 <sub>bin</sub> )	0xXX	0xXX

Explanation:

- Bit 0.7 set means: Register communication switched on.
- Bit 0.6 not set means: reading the register.
- Bits 0.5 to 0.0 specify the register number 9 with 00 1001<sub>bin</sub>.
- The output data word (byte 1 and byte 2) has no meaning during read access. To change a register, write the required value into the output word.

#### Input Data (answer of the bus terminal)

Byte 0: Status byte	Byte 1: DataIN1, high byte	Byte 2: DataIN1, low byte
0x89	0x33	0x41

Explanation:

- The terminal returns the value of the control byte as a receipt in the status byte.
- The terminal returns the firmware version 0x3341 in the input data word (byte 1 and byte 2). This is to be interpreted as an ASCII code:
  - ASCII code 0x33 represents the digit 3
  - ASCII code 0x41 represents the letter A
 The firmware version is thus 3A.

### 5.2.3.2 Example 2: Writing to a user register

#### **i** Code word

In normal mode all user registers are read-only with the exception of Register 31. In order to deactivate this write protection you must write the code word (0x1235) into Register 31. If a value other than 0x1235 is written into Register 31, write protection is reactivated. Please note that changes to a register only become effective after restarting the terminal (power-off/power-on).

#### I. Write the code word (0x1235) into Register 31.

#### Output Data

Byte 0: Control byte	Byte 1: DataOUT1, high byte	Byte 2: DataOUT1, low byte
0xDF (1101 1111 <sub>bin</sub> )	0x12	0x35

Explanation:

- Bit 0.7 set means: Register communication switched on.
- Bit 0.6 set means: writing to the register.
- Bits 0.5 to 0.0 specify the register number 31 with 01 1111<sub>bin</sub>.
- The output data word (byte 1 and byte 2) contains the code word (0x1235) for deactivating write protection.

**Input Data (answer of the bus terminal)**

Byte 0: Status byte	Byte 1: DataIN1, high byte	Byte 2: DataIN1, low byte
0x9F (1001 1111 <sub>bin</sub> )	0xXX	0xXX

Explanation:

- The terminal returns a value as a receipt in the status byte that differs only in bit 0.6 from the value of the control byte.
- The input data word (byte 1 and byte 2) is of no importance after the write access. Any values still displayed are invalid!

**II. Read Register 31 (check the set code word)**

**Output Data**

Byte 0: Control byte	Byte 1: DataOUT1, high byte	Byte 2: DataOUT1, low byte
0x9F (1001 1111 <sub>bin</sub> )	0xXX	0xXX

Explanation:

- Bit 0.7 set means: Register communication switched on.
- Bit 0.6 not set means: reading the register.
- Bits 0.5 to 0.0 specify the register number 31 with 01 1111<sub>bin</sub>.
- The output data word (byte 1 and byte 2) has no meaning during read access.

**Input Data (answer of the bus terminal)**

Byte 0: Status byte	Byte 1: DataIN1, high byte	Byte 2: DataIN1, low byte
0x9F (1001 1111 <sub>bin</sub> )	0x12	0x35

Explanation:

- The terminal returns the value of the control byte as a receipt in the status byte.
- The terminal returns the current value of the code word register in the input data word (byte 1 and byte 2).

**III. Write to Register 32 (change contents of the feature register)**

**Output data**

Byte 0: Control byte	Byte 1: DataIN1, high byte	Byte 2: DataIN1, low byte
0xE0 (1110 0000 <sub>bin</sub> )	0x00	0x02

Explanation:

- Bit 0.7 set means: Register communication switched on.
- Bit 0.6 set means: writing to the register.
- Bits 0.5 to 0.0 indicate register number 32 with 10 0000<sub>bin</sub>.
- The output data word (byte 1 and byte 2) contains the new value for the feature register.

**⚠ CAUTION**

**Observe the register description!**

The value of 0x0002 given here is just an example!

The bits of the feature register change the properties of the terminal and have a different meaning, depending on the type of terminal. Refer to the description of the feature register of your terminal (chapter *Register description*) regarding the meaning of the individual bits before changing the values.

**Input data (response from the Bus Terminal)**

Byte 0: Status byte	Byte 1: DataIN1, high byte	Byte 2: DataIN1, low byte
0xA0 (1010 0000 <sub>bin</sub> )	0xXX	0xXX

Explanation:

- The terminal returns a value as a receipt in the status byte that differs only in bit 0.6 from the value of the control byte.
- The input data word (byte 1 and byte 2) is of no importance after the write access. Any values still displayed are invalid!

**IV. Read Register 32 (check changed feature register)****Output Data**

Byte 0: Control byte	Byte 1: DataOUT1, high byte	Byte 2: DataOUT1, low byte
0xA0 (1010 0000 <sub>bin</sub> )	0xXX	0xXX

Explanation:

- Bit 0.7 set means: Register communication switched on.
- Bit 0.6 not set means: reading the register.
- Bits 0.5 to 0.0 indicate register number 32 with 10 0000<sub>bin</sub>.
- The output data word (byte 1 and byte 2) has no meaning during read access.

**Input Data (answer of the bus terminal)**

Byte 0: Status byte	Byte 1: DataIN1, high byte	Byte 2: DataIN1, low byte
0xA0 (1010 0000 <sub>bin</sub> )	0x00	0x02

Explanation:

- The terminal returns the value of the control byte as a receipt in the status byte.
- The terminal returns the current value of the feature register in the input data word (byte 1 and byte 2).

**V. Write Register 31 (reset code word)****Output Data**

Byte 0: Control byte	Byte 1: DataOUT1, high byte	Byte 2: DataOUT1, low byte
0xDF (1101 1111 <sub>bin</sub> )	0x00	0x00

Explanation:

- Bit 0.7 set means: Register communication switched on.
- Bit 0.6 set means: writing to the register.
- Bits 0.5 to 0.0 specify the register number 31 with 01 1111<sub>bin</sub>.
- The output data word (byte 1 and byte 2) contains 0x0000 for reactivating write protection.

**Input Data (answer of the bus terminal)**

Byte 0: Status byte	Byte 1: DataIN1, high byte	Byte 2: DataIN1, low byte
0x9F (1001 1111 <sub>bin</sub> )	0xXX	0xXX

Explanation:

- The terminal returns a value as a receipt in the status byte that differs only in bit 0.6 from the value of the control byte.
- The input data word (byte 1 and byte 2) is of no importance after the write access. Any values still displayed are invalid!

## 6 Appendix

### 6.1 Support and Service

Beckhoff and their partners around the world offer comprehensive support and service, making available fast and competent assistance with all questions related to Beckhoff products and system solutions.

#### Beckhoff's branch offices and representatives

Please contact your Beckhoff branch office or representative for [local support and service](#) on Beckhoff products!

The addresses of Beckhoff's branch offices and representatives round the world can be found on her internet pages:

<http://www.beckhoff.com>

You will also find further [documentation](#) for Beckhoff components there.

#### Beckhoff Headquarters

Beckhoff Automation GmbH & Co. KG

Huelshorstweg 20  
33415 Verl  
Germany

Phone: +49(0)5246/963-0  
Fax: +49(0)5246/963-198  
e-mail: [info@beckhoff.com](mailto:info@beckhoff.com)

#### Beckhoff Support

Support offers you comprehensive technical assistance, helping you not only with the application of individual Beckhoff products, but also with other, wide-ranging services:

- support
- design, programming and commissioning of complex automation systems
- and extensive training program for Beckhoff system components

Hotline: +49(0)5246/963-157  
Fax: +49(0)5246/963-9157  
e-mail: [support@beckhoff.com](mailto:support@beckhoff.com)

#### Beckhoff Service

The Beckhoff Service Center supports you in all matters of after-sales service:

- on-site service
- repair service
- spare parts service
- hotline service

Hotline: +49(0)5246/963-460  
Fax: +49(0)5246/963-479  
e-mail: [service@beckhoff.com](mailto:service@beckhoff.com)

## List of illustration

Fig. 1	KL3361 .....	10
Fig. 2	KL3362 .....	12
Fig. 3	Spring contacts of the Beckhoff I/O components.....	15
Fig. 4	Attaching on mounting rail .....	16
Fig. 5	Disassembling of terminal.....	17
Fig. 6	Power contact on left side.....	18
Fig. 7	Standard wiring.....	19
Fig. 8	Pluggable wiring .....	20
Fig. 9	High Density Terminals.....	20
Fig. 10	Connecting a cable on a terminal point .....	21
Fig. 11	Connecting the KL3361 .....	23
Fig. 12	Connecting the KL3362 .....	25
Fig. 13	KS2000 configuration software.....	28
Fig. 14	Display of the fieldbus station in KS2000 .....	30
Fig. 15	KS2000 tree branches for channel 1 of the KL3681 .....	31
Fig. 16	Trigger logic for KL3361 .....	32
Fig. 17	Trigger values for KL3361 .....	33
Fig. 18	Process data for KL3361 .....	34
Fig. 19	Trigger logic for KL3362 .....	35
Fig. 20	General settings for KL3362 .....	36
Fig. 21	Trigger values for KL3362 .....	37
Fig. 22	Process data for KL3362 .....	38
Fig. 23	Selecting the input value for data word 0.....	45
Fig. 24	Selecting the input value for data word 1.....	46
Fig. 25	Selecting the input value for data word 2 (KL3362 only) .....	46
Fig. 26	Selecting the input value for data word 3 (KL3362 only) .....	46
Fig. 27	Settings of KL3314 via visualisation of TwinCAT 3 .....	47
Fig. 28	Opening the *.tnzip archive.....	47
Fig. 29	Search of the existing HW configuration for the EtherCAT configuration of the example .....	48