

# ASi Safety Output Module with ASi Diagnostic node

Safety outputs, safety inputs and standard inputs in one module

4 x electronic safe outputs

2 x 2-channels safe inputs, adjustable as floating contacts or OSSDs or standard inputs

2 (up to 6) standard inputs



(figure similar)

## Article no. BWU3064: ASi Safety Output Module with ASi Diagnostic node

The addresses are set by a configuration node via the ASIMON. All ASi Safety Output Modules with the same safety address switch simultaneously.

Additional AB addresses are available for diagnostics including 4 inputs for EDM and 4 standard outputs to control the safety outputs.

<b>Article no.</b>	<b>BWU3064</b>
<b>Connection</b>	
ASi/AUX connection	profile cable and piercing
Periphery connection	M12
Length of connector cable	unlimited <sup>(1)</sup>
<b>ASi</b>	
Profile	safe ASi input nodes: S-0.B.0 (ID1=F) and S-0.B.1 (ID1=F) ASi diagnostic nodes: S-7.A.E (ID1=5) 4I/4O ASi nodes: S-7.E (ID1=F) ASi configuration node: S-7.A.5 (ID1=7)
Addresses	depending on configuration
Required Master profile	≥M3
Since ASi specification	3.0
Operating voltage	30 V <sub>DC</sub> (18 ... 31,6 V)
Max. current consumption	<200 mA
<b>AUX</b>	
Voltage	24 V (18 ... 30 V)
Max. current consumption	4 A <sup>(2)</sup>
<b>Input</b>	
Number	2 standard inputs (up to 6, depending on configuration) 2 x 2-channels safe inputs (SIL3, cat. 4, PLe) for floating contacts or OSSD
Power supply	out of AUX
Power supply of attached sensors	max. 150 mA <sup>(2)</sup> <sup>(3)</sup>
Switching current	15 mA (T = 100 μs), continuously 4 mA at 24 V
OSSD test pulses	0 ... 50 Hz
OSSD test pulse width	0 ... 51 ms, adjustable
Max. current for OSSD	1 A <sup>(2)</sup> <sup>(4)</sup>
Switching threshold	<5 V (low) >15 V (high)

# ASi Safety Output Module with ASi Diagnostic node

<b>Article no.</b>	<b>BWU3064</b>
<b>Output</b>	
Number	4 release circuits; 4 x electronic safe outputs
Max. contact load	2 A at 24 V (1,0 A <sub>DC-13</sub> at 24 V) <sup>(2) (4)</sup>
Power supply	out of AUX
Max. output current	safety output: max. 1 A, $\Sigma = 4 \text{ A}$ <sup>(2) (4)</sup>
Test pulse	if output is on: minimum interval between 2 test pulses: 250 ms pulse width: 1 ms
<b>Display</b>	
LED ASI (green)	on: ASi voltage on flashing: ASi voltage on, but peripheral fault or ASi address 0 off: no ASi voltage
LED FLT/FAULT (red)	on: ASi address 0 or ASi node offline flashing: peripheral fault off: ASi node online
LED AUX (green)	on: 24 V <sub>DC</sub> AUX off: no 24 V <sub>DC</sub> AUX
LED MP (green / yellow / red)	off: no chip card plugged in or chip card defect green: chip card plugged in and recognized yellow flashing: copying configuration from chip card to unconfigured module or from module to empty chip card red: configuration on chip card and module different or configuration on chip card incompatible with the device
LEDs I1 ...Ix (yellow)	state of standard inputs I1, I2
LEDs S1 ... Sx (yellow)	state of safety inputs S1 ... S4
LEDs SO1 ... SOx (yellow)	state of safety outputs SO1 ... SO4
<b>Environment</b>	
Applied standards	EN 61000-2 EN 61000-3 EN 61131-2 EN 62061 EN ISO 13849-1 EN 60529
Can be used in passively safe paths up to SIL3/PLe	yes <sup>(5)</sup>
Operating altitude	max. 2000 m
Ambient Operating temperature	-30 °C ... +40 °C (-30 °C ... +70 °C <sup>(2) (3) (4)</sup> )
Storage temperature	-30 °C ... +85 °C
Housing	plastic, for screw mounting
Pollution Degree	2
Protection category	IP67 <sup>(6)</sup>
Tolerable loading referring to humidity	according to EN 61131-2
Max. tolerable shock load	30g, 11 ms, acc. EN 61131-2
Max. tolerable vibration stress	5 ... 8 Hz 50 mm <sub>pp</sub> /8 ... 500 Hz 6g, acc. EN 61131-2
Voltage of insulation	≥500 V
Weight	225 g
Dimension (W / H / D in mm)	60 / 151 / 46

<sup>(1)</sup> loop resistance ≤150 Ω

# ASi Safety Output Module with ASi Diagnostic node

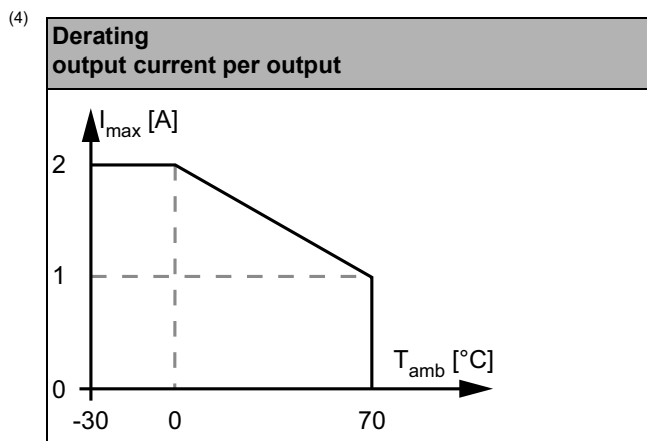
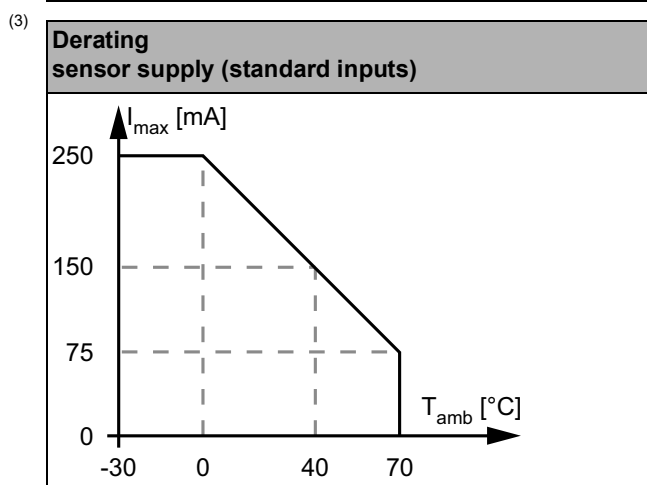
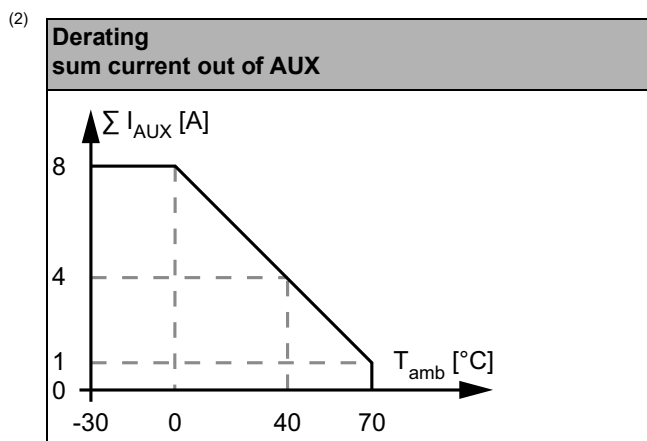

- (5) The module is suitable for use in passively safe paths because an exclusion of errors can be assumed for the connection of the two potentials, ASi and AUX.
- (6) IP67 can only be achieved if all open M12 sockets are sealed with suitable protection caps (see accessories).

<b>UL-specifications (UL508)</b>	
<b>BWU3064</b>	
External protection	An isolated source with a secondary open circuit voltage of $\leq 30 V_{DC}$ with a 3 A maximum over current protection. Over current protection is not required when a Class 2 source is employed.
In general	UL mark does not provide UL certification for any functional safety rating or aspects of the above devices.

# ASi Safety Output Module with ASi Diagnostic node

## Pin assignment

Signal name	Explanation
Ix	standard input x
Sx	safety input x, configurable as OSSD, floating contacts or standard input
SOx	safety output x
T1, T2	clock output
24 V <sub>ext.out</sub>	power supply, out of external voltage, positive pole
0 V <sub>ext.out</sub>	power supply, out of external voltage, negative pole
n.c.	not connected

## Connections

Article no.	M12 connect.	Marking	Pin1	Pin2	Pin3	Pin4	Pin5		
BWU3064	X1	I1	24 V <sub>ext.out</sub>	I2	0 V <sub>ext.out</sub>	I1	n.c.	X1	
	X2	I2	24 V <sub>ext.out</sub>	n.c.	0 V <sub>ext.out</sub>	I2	n.c.	X2	
	X3	S11/S12	standard	24 V <sub>ext.out</sub>	I5	0 V <sub>ext.out</sub>	I3	n.c.	X3
			float. cont.	T2	S12	n.c.	S11	T1	X4
	X4	S21/S22	standard	24 V <sub>ext.out</sub>	I6	0 V <sub>ext.out</sub>	I4	n.c.	X5
			float. cont.	T2	S22	n.c.	S21	T1	X6
	X5	SO1	OSSD	24 V <sub>ext.out</sub>	S22	0 V <sub>ext.out</sub>	S21	n.c.	X7
			standard	n.c.	SO1-	0 V <sub>ext.out</sub>	SO1+	n.c.	X8
	X6	SO2	n.c.	SO2-	0 V <sub>ext.out</sub>	SO2+	n.c.	MP	
	X7	SO3	n.c.	SO3-	0 V <sub>ext.out</sub>	SO3+	n.c.	ADDR	
X8	SO4	n.c.	SO4-	0 V <sub>ext.out</sub>	SO4+	n.c.			
ADDR	connection for ASi-3 addressing plug (protection cap)								
MP	memory plug (protection cap)								

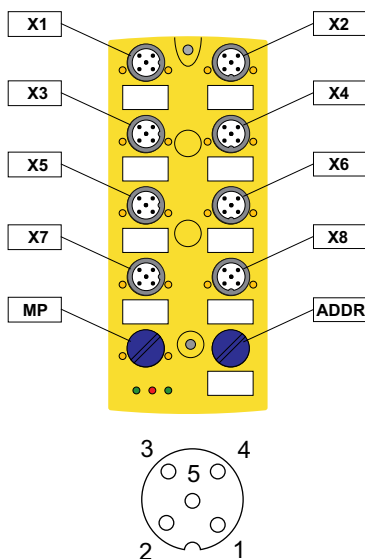

## Safety outputs (SO)

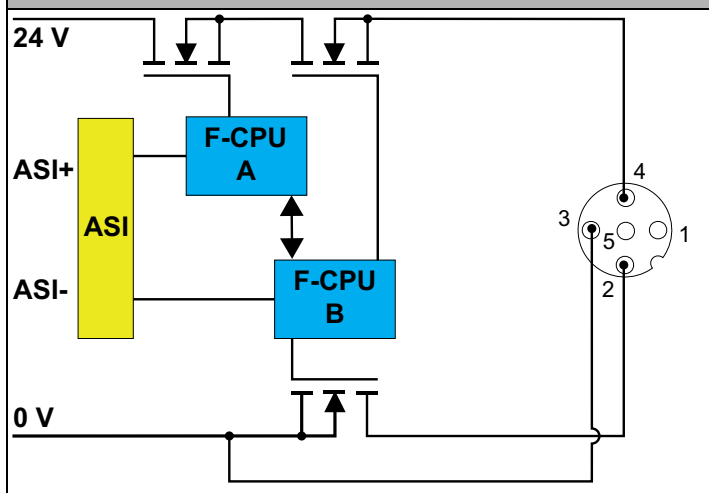

# ASi Safety Output Module with ASi Diagnostic node

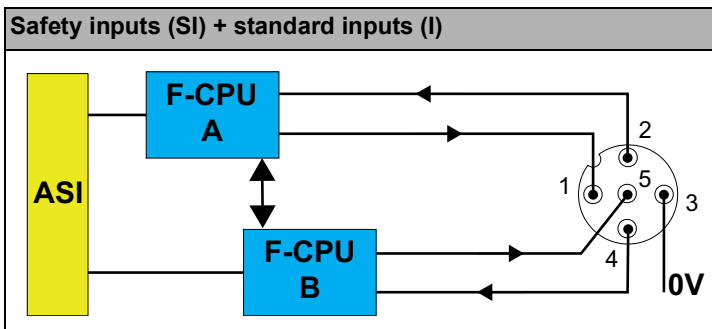

## Programming instructions (ASi bit assignment for safe inputs)

Bit	D3	D2	D1	D0
Safe input SI1 (S11/S12)	S12	S12	S11	S11
Safe input SI2 (S21/S22)	S22	S22	S21	S21

## Programming instructions (bit assignment of ASi standard I/O nodes)

Programming	ASi bit assignment			
	D3	D2	D1	D0
Bit	D3	D2	D1	D0
	<b>input</b>			
Node 1	I4	I3	I2	I1
Node 2	not used	not used	I6	I5
	<b>output</b>			
Node 1	if P0=1: SO4	if P0=1: SO3	if P0=1: SO2	if P0=1: SO1
Node 2	not used	not used	not used	not used
	<b>parameter bit</b>			
	P3	P2	P1	P0
Node 1	not used	not used	not used	0: no influence on SO <sub>n</sub> 1: switches output SO <sub>n</sub> on, if safety release <sup>(1)</sup> is active and bit D <sub>n-1</sub> = 1
Node 2	not used	not used	not used	not used

<sup>(1)</sup> see table „Release conditions“

## Programming instructions (Bit values of the ASi diagnostic node 1, 2, 3 and 4)

Bit	ASi Output	Bit	ASi Input
O3	inexistent	I3	<b>Parameter P2</b> 1: response input I <sub>x</sub> (x = 1 ... 4) 0: response of state of release
O2	not used	I2	diagnostics (for definition see table „Device colors“)
O1	not used	I1	
O0	<b>Parameter P1=1</b> not used <b>Parameter P1=0</b> 1: switches output SO <sub>n</sub> on, if the safety release <sup>(1)</sup> is active 0: switches output SO <sub>n</sub> off, even if the safety release <sup>(1)</sup> is active	I0	

Peripheral fault indicates missing 24 V<sub>ext</sub>.

<sup>(1)</sup> see table „Release conditions“

# ASi Safety Output Module with ASi Diagnostic node

## Programming instructions (bit values of the ASi parameter, diagnostic node)

Bit	ASi Parameter
<b>Bit P1</b>	
<b>P1=0</b>	Safety output SO <sub>n</sub> controlled by safety release <sup>(1)</sup> and O0=1
<b>P1=1</b>	Safety output SO <sub>n</sub> controlled by safety release only <sup>(1)</sup>

<sup>(1)</sup> see table „Release conditions“

## Release conditions

		ASi Standard I/O nodes			
		node 1			
		Parameter P0 = 0	Parameter P0 = 1		
			Bit D <sub>n-1</sub> = 0	Bit D <sub>n-1</sub> = 1	
ASi diagnostic node	node 1 ... 4s	Parameter P1 = 1	SO <sub>n</sub> = release	SO <sub>n</sub> = off	SO <sub>n</sub> = release
		Parameter P1 = 0	SO <sub>n</sub> = release	SO <sub>n</sub> = off	SO <sub>n</sub> = release
		Bit O0 = 0	SO <sub>n</sub> = off	SO <sub>n</sub> = off	SO <sub>n</sub> = off





















## Diagnostics (device colors)

Value	Color	Description	State change	LED SO <sub>n</sub>
0	green	output on		on
1	green flashing	–		–
2	yellow	restart inhibit	auxiliary signal 2	1 Hz
3	yellow flashing	–		–
4	red	output off		off
5	red flashing	waiting for "reset of error condition" or AUX is missing	auxiliary signal 1 or connect AUX	8 Hz
6	gray	internal error, such as "fatal error"	only via "Power ON" on device	all LEDs flashing
7	green/yellow	output released, but not switched on	switching-on by setting of O0	off

## LED status display

LED	State	Signal / Description
AUX (green)		no 24 V <sub>DC</sub> AUX
		24 V <sub>DC</sub> AUX present
ASi (green)		no ASi voltage
		ASi voltage present, but at least one ASi node is addressed „0“ or peripheral fault
		ASi voltage present

# ASi Safety Output Module with ASi Diagnostic node

LED	State	Signal / Description
FLT (red)		ASi communication OK (at least one ASi node online)
	 1 Hz	at least one ASi node with peripheral fault
		no data exchange (with at least one correctly addressed ASi node)
I1, I2 (yellow)		input is switched off
		input is switched on
MP (green / yellow / red)		no chip card plugged in or chip card defect
	 1 Hz	copying configuration from chip card to unconfigured module or from module to empty chip card
		chip card plugged in and recognized
		configuration on chip card and device different or configuration incompatible with the device, user intervention is required.
S11 ... S22 (yellow)		safety input is switched off
	 1 Hz	cross-connection
	 8 Hz	internal error or double address
		safety input is switched on
SO1 ... SO4 (yellow)		safety output is switched off
	 1 Hz	restart block, waiting for the start signal to switch on the safety output again
	 8 Hz	unlockable error state; waiting for "reset of error condition signal", after receiving the signal the device turns into normal operation
		safety output is switched on
 LED on  LED flashing  LED off		

 In case all LEDs are blinking simultaneously in fast rhythm a fatal error has been detected. This message is reset by a short disconnection of the power supply (Power ON Reset).

## Accessories:

- ASi substructure module (CNOMO) for 8 channel module in 60 mm housing (art. no. BW2351)
- Memory Plug, memory capacity 32 kByte (art. no. BW3241)
- Universal protection cap ASi-5/ASi-3 for M12 sockets, IP67 (art. no. BW4056)
- Memory plug cover (art. no. BW3155)
- Sealing profile IP67 (IDC plug), 60 mm (art. no. BW3282)
- Passive Distributor AUX to 1 x M12 cable plug, straight, 4 poles, depth 19 mm, IP67, optimized for load currents  $\geq 100$  mA (art. no. BWU4725)
- Passive Distributor AUX to 1 x M12 cable plug, straight, 4 poles, depth 19 mm, IP67, optimized for load currents  $\leq 100$  mA (art. no. BWU4760)
- ASi-5/ASi-3 Address Programming Device (art. no. BW4708)