

## Junction box • Resistant to rolling oil

Series GS 125 / GS 175 / GS 250

Connection of sensors with armoured cable

IP 68-plug



Design	GS 125	GS 175	GS 250
Dimensions			
ID-No.	P31212	P31217	P31218
Type	GS 125	GS 175	GS 250
Connectable sensors	2	3	4
Supply voltage [V]	10...55 DC	10...55 DC	10...55 DC
Ambient temperature [°C]	-20...+75	-20...+75	-20...+75
Protection [EN 60529]	IP 68	IP 68	IP 68
Housing material	Aluminium	Aluminium	Aluminium
Connection	10 m TPE-numbered cable 7x0.5mm <sup>2</sup>	10 m TPE-numbered cable 7x0.5mm <sup>2</sup>	10 m TPE-numbered cable 7x0.5mm <sup>2</sup>

Plug, Lemo series K, 3-pol

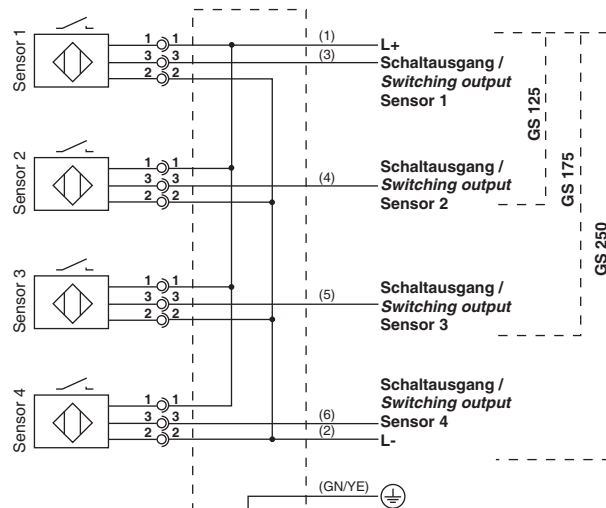
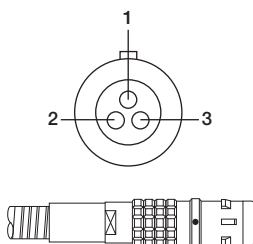

Notice

for sensors IGMF 010 GSP-PZ / INFW 020 GSP-PZ, page 3.23