

Operating Manual

ME49F

Pressure Transmitter

for applications in explosive areas
According to ATEX Directive 2014/34/EU
Gas explosion protection zone 1



Table of contents

- 1 Safety instructions
- 2 Application purpose
- 3 Product and function description
- 4 Installation and assembly
- 5 Start-up
- 6 Maintenance
- 7 Transportation
- 8 Service
- 9 Accessories
- 10 Waste disposal
- 11 Technical Data
- 12 Dimensional drawings
- 13 Order codes
- 15 Attachments

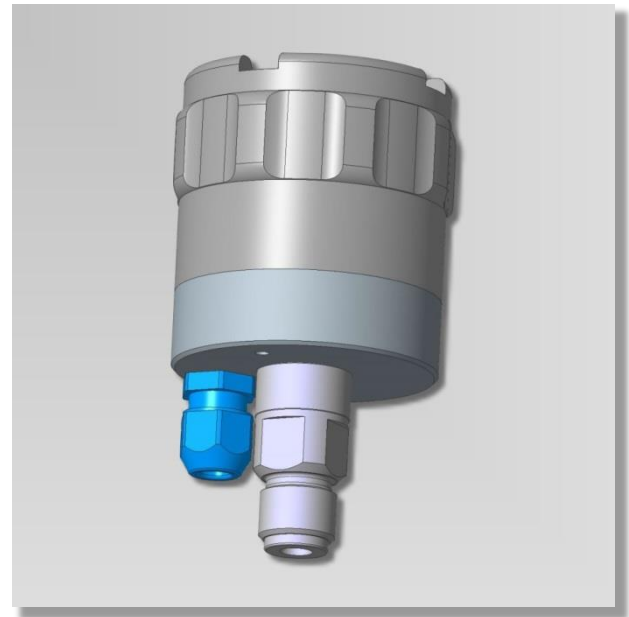

1 Safety instructions

1.1 General



This operating manual contains instructions fundamental to the installation, operation and maintenance of the device that must be observed unconditionally. It

must be read by the assembler, operator and the specialized personnel in charge of the instrument before it is installed and put into operation. This operating manual must always be accessible at the place of installation.

The subsequent sections on general safety instructions 1.2 - 1.7 as well as the following special instructions ranging from intended use to disposal 2-10 contain important safety instructions the non-observance of which can cause danger to persons, animal and physical objects.

1.2 Personnel Qualification

The instrument may only be installed and commissioned by specialized personnel familiar with the installation, commissioning and operation of this product.

Specialized personnel are persons who can assess the work they have been assigned and recognize

potential dangers by virtue of their specialized training, their skills and experience and their knowledge of the pertinent standards.

For explosion-proof models the specialized personnel must have received special training or instruction or be authorized to work with explosion-proof instruments in explosion hazard areas.

1.3 Risks due to Non-Observance of Safety Instructions

Non-observance of these safety instructions, the intended use of the device or the limit values given in the technical specifications can be hazardous or cause harm to persons, the environment or the plant itself. Fischer Mess- und Regeltechnik GmbH will not be liable for damage claims if this should happen.

1.4 Safety Instructions for the Operating Company and the Operator

The safety instructions governing correct operation of the instrument must be observed. The operating company must make them available to the installation, maintenance, inspection and operating personnel. Dangers arising from electrical components, energy

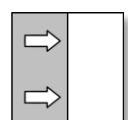

discharged by the medium, escaping medium and incorrect installation of the instrument must be eliminated. For more information, please see the applicable national and international regulations, such as DIN, EN, accident prevention regulations (UVV) and - for industry-specific individual applications - also in the industry guidelines issued by the DVWG, Ex, GL, etc. as well as VDE and local EVUs.

The instrument must be decommissioned and secured against inadvertent re-operation if a situation arises in which it must be assumed that safe operation is no longer possible. Reasons for this assumption could be:

- evident damage to the instrument
- failure of the electrical circuits
- long storage in temperatures over 85°C
- considerable strain due to transport

Repairs may be carried out by the manufacturer only.

A professional single conformity inspection as per DIN EN 61010, section 1, must be carried out before the instrument can be re-commissioned. This inspection must be performed at the manufacturer's location. Correct transport and storage of the instrument are required.

1.5 Unauthorised Modification

Modifications of or other technical alterations to the instrument by the customer are not permitted. This also applies to replacement parts. Any modifications/alterations required will be carried out by Fischer Mess- und Regeltechnik GmbH only.

1.6 Impermissible modes of operation

The operational safety of this instrument can only be guaranteed if it is used as intended. The instrument model must be suitable for the medium used in the system. The limit values given in the technical data may not be exceeded.

1.7 Safe working practices for maintenance and installation work

The safety instructions given in this operating manual, any nationally applicable regulations on accident prevention and any of the operating company's internal work, operating and safety guidelines must be observed.

The operating company is responsible for ensuring that all required maintenance, inspection and installation work is carried out by qualified specialized personnel.

1.8 Pictogram explanation



WARNING!

... indicates a potentially dangerous situation, non-observance of which could endanger persons, animals, the environment or objects.



INFORMATION!

... highlights important information efficient and smooth operation.



TIP!

... indicates recommendations that are not specifically necessary in certain situations but which could be useful.

2 Application purpose

The two-line pressure transmitter ME49F* serves precise recording of a pressure with a resistance pressure cell in the ex-area.



The supply circuit on terminals 1 and 2 must correspond to ignition protection type 'Inherent safety' of category 'ib'.

The units are may only be used for the purpose defined by the manufacturer in the data sheet or operating instructions.



The maximum allowed temperature range from -20°C to +60°C may not be exceeded.

If there is dirty or aggressive media in the system, or if this is to be expected, the device must be modified in terms of those parts that come into contact with the media. Please talk to the manufacturer first before ordering.



The corresponding setup regulations are to be considered for each application case.

Designation as per guideline 2014/34/EU

⊕ II 2G Ex ib IIC T6 Gb

3 Product and function description

3.1 Function diagram

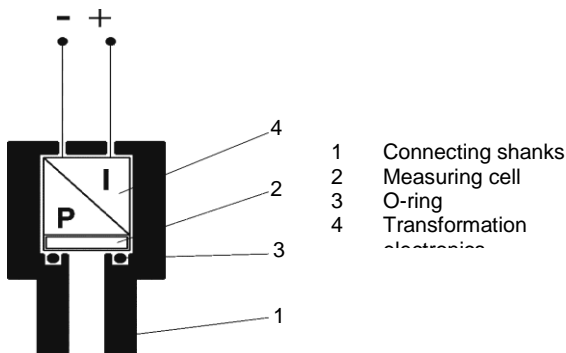

3.2 Design and mode of operation

The measuring pressure acts on a ceramic membrane that deforms when under pressure.

The output signal on the measurement bridge attached to rear of the membrane changes when the membrane deforms.

Electronics integrated into the pressure transmitter housing converts the sensor signal into an electronic uniform signal 4...20mA um.

4 Installation and assembly

As standard, the unit has a cylindrical pipe thread and flat seal for screwing into the screw holes.

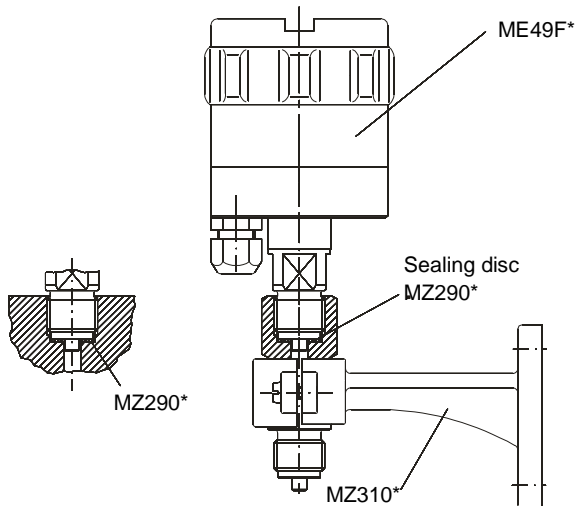

Wall assembly is possible when the wall holder MZ310* is used.

The manometer screw connections MZ27* allow pipes to be connected directly.

The device is set ex-works for vertical installation, however any installation position is possible. In installation positions that vary from the vertical, the zero-point can be corrected using the installed zero-point potentiometer (5.1).

To guarantee safe working conditions during installation and maintenance, suitable stop valves must be fitted in the system. The shutoff valves of the Fischer series MZ5* make it possible to

- depressurize or decommission the unit,
- or to disconnect it from the power supply within the applicable system for repairs or inspections
- or to check the functions of the unit on site.

Thanks to their venting screws, the shut-off valves allow the connected pipe system to be vented.

4.1 Process connection

Dangers caused by pressure on the instrument are to be prevented with suitable measures.

- By authorized and qualified specialized personnel only.
- Only for the designated mechanical process connection - for the model, see the order code on the device type plate.
- The pipes need to be depressurized when the device is being connected.
- Appropriate steps must be taken to protect the device from pressure surges.
- Check the suitability of the device for the media to be measured.
- Observe the maximum pressure.
- The pressure measuring line must be installed on a gradient so that no air pockets e.g. for liquid measurements or water pockets e.g. for gas measurements can be created. If the required incline is not reached, water and/or air filters need to be installed at suitable points.
- The pressure sensing lines need to be kept as short as possible and installed without sharp bends to avoid interfering delay times.

4.2 Pressure surge absorption

Dangers caused by pressure on the instrument are to be prevented with suitable measures.

Pulsating pressure on the system side can lead to functional problems. As a protective measure, we recommend the installation of damping elements in the pressure connection lines.

4.2.1 For gas-like media

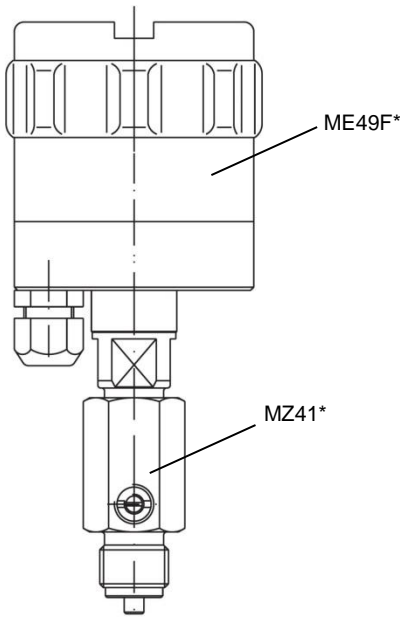

Fig. 1 Damping reactor MZ41*

When operational, set the throttle needle so that the output signal is settled as required.

4.2.2 In the case of fluid media

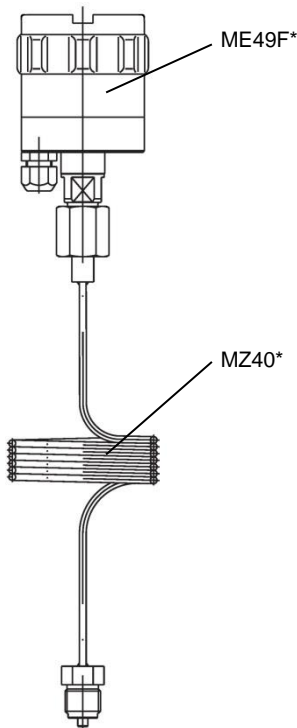

Fig. 2 Capillary throttle coils MZ40*

4.3 Electrical connections



The ME49F* is an intrinsically-safe piece of equipment for use in potentially explosive areas. For connection of the intrinsically safe supply current circuit, the details in the type approval certificate apply.

- For ex-operations, observe the electrical data of the EC type examination certificate (see attachment) and the local applicable regulations and guidelines for the installation and operation of electrical installations in potentially explosive areas.
- By authorized and qualified specialized personnel only.
- Disconnect the system from the mains before connecting the device.
- Add a fuse adapted to the energy requirements.

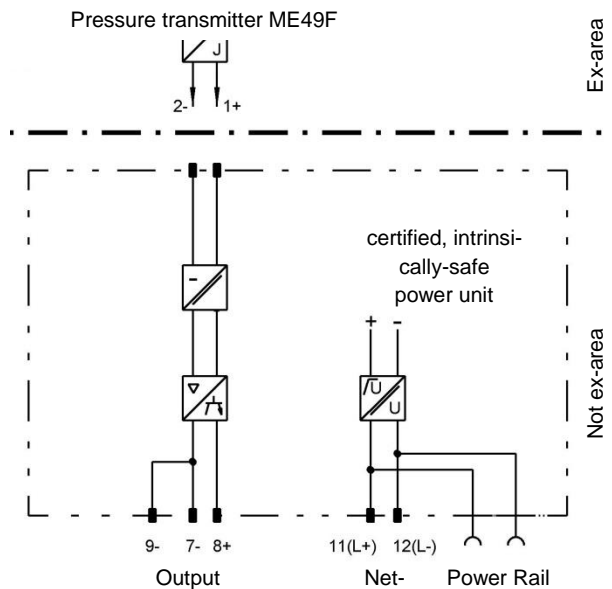

5 Start-up

- All electrical supply, operating and measuring lines and the pressure connections must have been correctly installed before commissioning. All supply lines are arranged so that there are no mechanical forces acting on the device.
- Check that the pressure connections do not leak before commissioning.

5.1 Zero point and measuring range adjustment



Please note that adjustments can only be carried out in ex-free zone.

The pressure transmitters are set in the factory before delivery so that they do not usually need to be adjusted at the assembly site. If the output signal does need to be adjusted, this can be undertaken using the 'S' and 'N' potentiometers.

The potentiometers can be accessed by unscrewing the lid of the housing. The unit is connected to the power supply as shown on the wiring diagram and also, an ammeter is connected between the pressure transmitter and the auxiliary energy source.

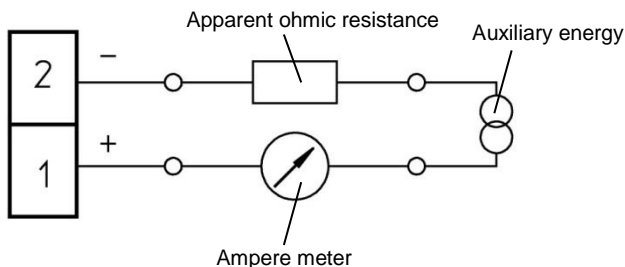

Fig. 3 Measuring switch

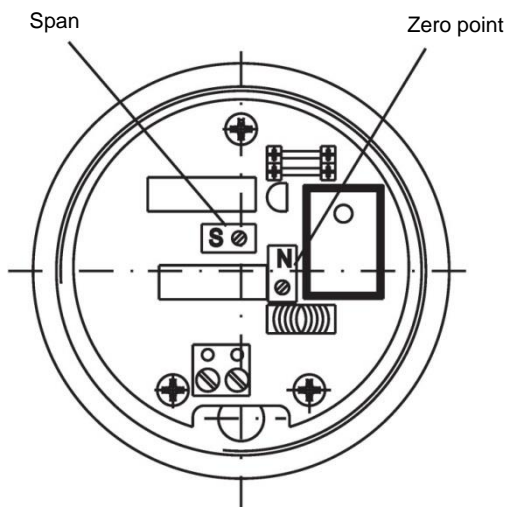

Fig 4 Setting potentiometer

5.2 Adjustment sequence:

- Switch on auxiliary energy
- Depressurize the measuring system: $p = 0$
- Display for std. measuring ranges = 4.0 mA
- In the case of any deviations, the output signal of the pressure transmitter shown by the ammeter can be corrected with the zero-point potentiometer (N).

- Set the pressure in the measuring system to the measuring range end value (e.g. pressure is generated by means of a manual pump and pressure compensation unit) Display 20 mA. In case of differences, correct by adjusting the voltage potentiometer (S).
- Then check the zero-point and measuring range again; correct if necessary.

6 Maintenance

The instrument is maintenance-free.

We recommend checking the instrument at regular intervals to ensure reliable operation and a long service life.

- Inspecting the output signal.
- Check the leak-tightness of the pressure connection lines.
- Check the electrical connection (cable clamp connections).

The precise test cycles and operating and ambient conditions need to be adjusted. If various instrument components interact, the operating instructions of all the other instruments also need to be observed.

7 Transportation

The measuring device must be protected against impacts. It may only be transported in packaging specifically intended for transport.

8 Service

All defective or faulty devices should be sent directly to our repair department. We would ask you to please coordinate all return shipments with our sales department so that we can ensure careful processing of all faulty devices for our customers.



Process media residues in and on dismantled devices can be a hazard to people, animals and the environment. Take adequate preventive measures. If required, the devices must be cleaned thoroughly.

9 Accessories

Not planned

10 Waste disposal



For the sake of the environment

Please help to protect our environment and dispose of or recycle used instruments as stipulated by the applicable regulations.

11 Technical Data

Measuring range	40 mbar	60 mbar	100 mbar	160 mbar	250 mbar	400 mbar	600 mbar	1 bar
Overpressure-proof	4 bar	4 bar	4 bar	6 bar	6 bar	6 bar	10 bar	4 bar

Measuring range	1.6 bar	2.5 bar	4 bar	6 bar	10 bar	16 bar	25 bar	40 bar
Overpressure-proof	4 bar	8 bar	8 bar	12 bar	32 bar	32 bar	60 bar	60 bar

Ambient conditions

Admissible ambient temperature	-20° to +60°C
Permissible medium temperature	-20° to +60°C
Admissible storage temperature	-30° to +70°C

Electrical data

Rated Voltage	24 V DC
Allowed operating voltage U_b	15 ... 30 V DC



Limit value of the supply power circuit

Voltage U_i	≤ 30 V
Current I_i	≤ 100 mA
Output P_i	≤ 750 mW
effective inner capacity C_i	15 nF
effective inner inductivity L_i	90 mH
Capacity between the power circuit and housing.	≤ 2.2 nF
Output signal	4... 20 mA
Electrical connection type	Two-wire
Load at rated voltage	≤ 450 Ω
Apparent ohmic resistance	$R_L [\Omega] \leq (U_b - 15 \text{ V}) / 0.02 \text{ A}$
Current/voltage limit	ca. 30 mA
Temperature drift, zero-point	0.4 % FS/10 K
Temperature drift, measuring range	0.05 % FS/10 K
Linearity	$\pm 0.5\%$ of the measuring range
Hysteresis	$< 0.1\%$ of the measuring range

Connection, materials, assembly

Discharge port	Connection shank G1/2B acc. to DIN EN 837
Electrical connection	Inside screw terminal, cable screw connection M16 x 1.5
Protection	IP 65 acc. to DIN EN 60529
Materials of parts that come into contact with the medium	Chromium nickel steel 1.4571, ceramic, FPM
Casing material	Aluminium, painted
Assembly	Tap of sleeve assembly acc. to DIN EN 837 Wall assembly using the wall holder MZ310* and manometer adapter MZ290* Manometer screw connections MZ27* allow pipes to be connected directly

Identification

	CE 0044
	Ⓢ II 2G Ex ib IIC T6 Gb
EC Examination Certificate	BVS 03 ATEX E 414

12 Dimensional drawings

(all dimensions in mm unless otherwise specified)

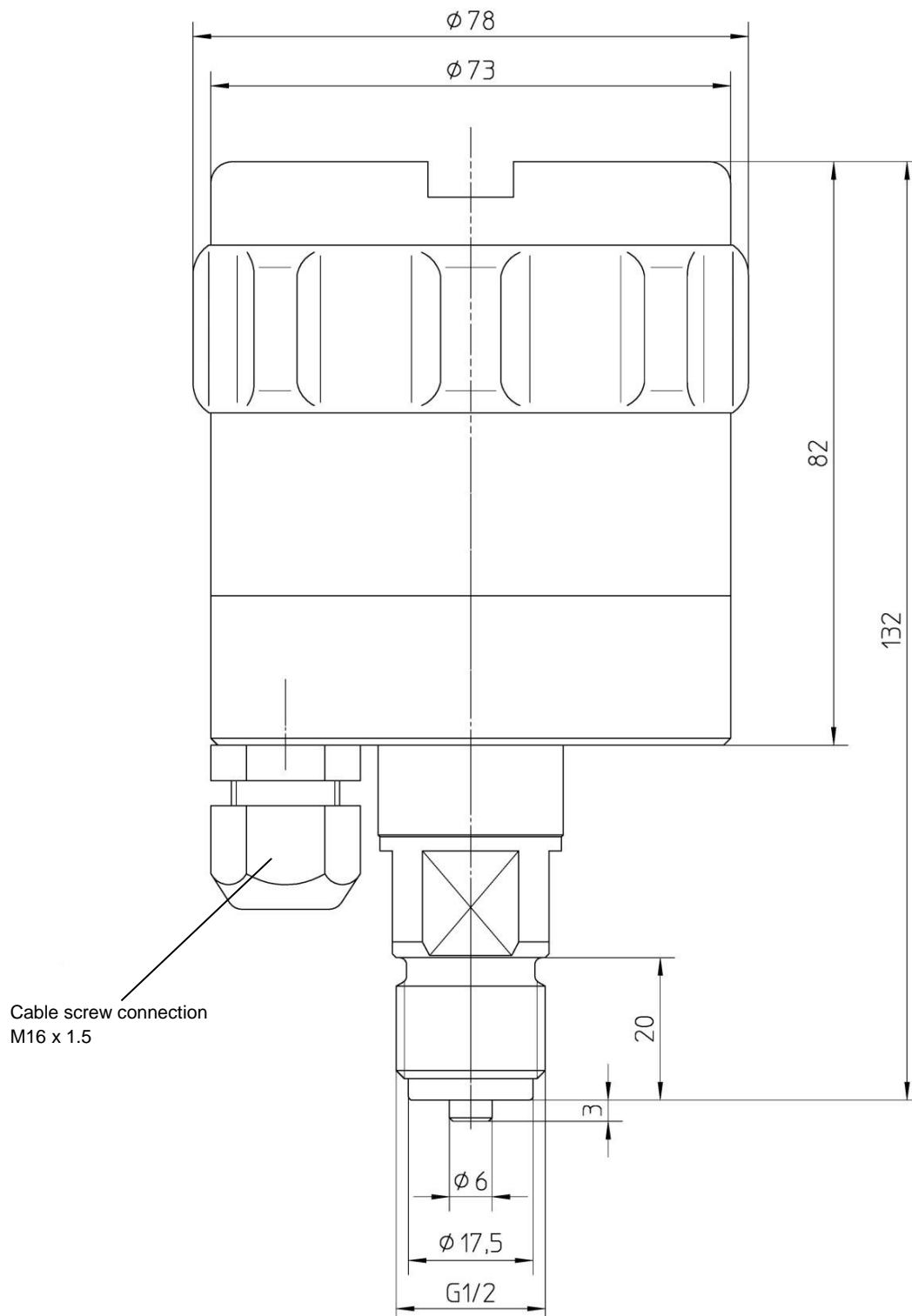

13 Order codes

Pressure Transmitter

Type ME49

F			8	7	B	E	A	0	0	0	0
---	--	--	---	---	---	---	---	---	---	---	---

EXECUTION

Version in Fischer field housing.....> F

Measuring range

- 25... 25 mbar.....> B 2
- 0... 40 mbar.....> 5 7
- 0... 60 mbar.....> 5 8
- 0... 100 mbar.....> 5 9
- 0... 160 mbar.....> 6 0
- 0... 250 mbar.....> 8 2
- 0... 400 mbar.....> 8 3
- 0...0.6 bar.....> 0 1
- 0...1 bar.....> 0 2
- 0...1.6 bar.....> 0 3
- 0...2.5 bar.....> 0 4
- 0...4 bar.....> 0 5
- 0...6 bar.....> 0 6
- 0...10 bar.....> 0 7
- 0...16 bar.....> 0 8
- 0...25 bar.....> 0 9
- 0...40 bar.....> 1 0
- 1...0 bar.....> 3 1
- 1... 0.6 bar.....> 3 2
- 1... 1.5 bar.....> 3 3
- 1...3 bar.....> 3 4
- 1...5 bar.....> 3 5
- 1...9 bar.....> 3 6
- 1...15 bar.....> 3 7

Discharge port

Connecting pin with outer thread G1/2B bottom, Niro.....> 8 7

Electrical output signal

4 - 20 mA linear, 2-LINE.....> B

Electrical connection

Inner terminal strip.....> E

Operating voltage

15 - 30 V DC.....> A

15 Attachments



EU Declaration of Conformity

(Translation)

For the product described as follows

Product designation **Pressure Transmitter**
Type designation **ME49 F**

it is hereby declared that it corresponds with the basic requirements specified in the following designated directives:

- 2014/30/EU *EMC Directive*
- 2014/34/EU *ATEX Directive*
- 2011/65/EU *RoHS Directive*

The products were tested in compliance with the following standards.

- Electromagnetic compatibility (EMC)**
- EN 61326-1:2013 *Electrical equipment for measurement, control and laboratory use - EMC requirements - Part 1: General requirements*
- EN 61326-2-3:2013 *Electrical equipment for measurement, control and laboratory use - EMC requirements - Part 2-3: Particular requirements - Test configuration, operational conditions and performance criteria for transducers with integrated or remote signal conditioning*

- Explosive atmospheres (ATEX)**
- EN 60079-0:2012 + A11:2013 *Explosive atmospheres - Part 0: Equipment - General requirements*
- EN 60079-11:2012 *Explosive atmospheres - Part 11: Equipment protection by intrinsic safety "i"*

- RoHS**
- EN 50581:2012 *Technical documentation for the assessment of electrical and electronic products with respect to the restriction of hazardous substances*

The notified office **DEKRA EXAM GmbH NB 0158** performed the CE-type examination and issued the following certificate: **BVS 03 ATEX E 414**

The notified office **TÜV NORD CERT GmbH NB 0044** is responsible for monitoring the QS Management. Also they were subjected to the conformity assessment procedure „**EC-type examination**“.

The object of the declaration described above is in conformity with Directive 2011/65/EU of the European Parliament and of the Council of 8 June 2011 on the restriction of the use of certain hazardous substances in electrical and electronic equipment.

Sole responsibility for the issue of this declaration of conformity in relation to fulfilment of the fundamental requirements and the production of the technical documents is with the manufacturer.

Manufacturer **FISCHER Mess- und Regeltechnik GmbH**
Bielefelder Str. 37a
32107 Bad Salzufflen, Germany
Tel. +49 5222 974 0

Documentation representative Mr. Stefan Richter
Dipl. Ing.
General Manager R & D

The devices bear the following marking: **CE** 0044

Ex II 2GEx ib IIC T6 Gb

Bad Salzufflen, 2016-11-15 S. Richter
General Manager R & D





Translation

EC-Type Examination Certificate

- (1)
- (2) **- Directive 94/9/EC -**
Equipment and protective systems intended for use
in potentially explosive atmospheres
- (3) **BVS 03 ATEX E 414**
- (4) **Equipment: Pressure transmitter type ME 49 *****000***
- (5) **Manufacturer: Klaus Fischer**
- (6) **Address: 32107 Bad Salzuflen, Germany**
- (7) The design and construction of this equipment and any acceptable variation thereto are specified in the schedule to this type examination certificate.
- (8) The certification body of Deutsche Montan Technologie GmbH, notified body no. 0158 in accordance with Article 9 of the Directive 94/9/EC of the European Parliament and the Council of 23 March 1994, certifies that this equipment has been found to comply with the Essential Health and Safety Requirements relating to the design and construction of equipment and protective systems intended for use in potentially explosive atmospheres, given in Annex II to the Directive.
The examination and test results are recorded in the test and assessment report BVS PP 03.2268 EG.
- (9) The Essential Health and Safety Requirements are assured by compliance with:
EN 50014:1997 + A1 – A2 General requirements
EN 50020:2002 Intrinsic safety 'i'
- (10) If the sign "X" is placed after the certificate number, it indicates that the equipment is subject to special conditions for safe use specified in the schedule to this certificate.
- (11) This EC-Type Examination Certificate relates only to the design, examination and tests of the specified equipment in accordance to Directive 94/9/EC.
Further requirements of the Directive apply to the manufacturing process and supply of this equipment. These are not covered by this certificate
- (12) The marking of the equipment shall include the following:

II 2G EEx ib IIC T6

Deutsche Montan Technologie GmbH

Bochum, dated 02. December 2003

Signed: Dr. Jockers

Signed: Dr. Eickhoff

Certification body

Special services unit



(13) Appendix to
(14) **EC-Type Examination Certificate**
BVS 03 ATEX E 414

(15) 15.1 Subject and type

Pressure transmitter	type ME 49 * * * * * 000*
Construction in Fischer type field housing	= F
Measuring range	
0 up to 40 mbar	= 57
0 up to 60 mbar	= 58
0 up to 100 mbar	= 59
0 up to 160 mbar	= 60
0 up to 250 mbar	= 82
0 up to 400 mbar	= 83
0 up to 0.6 bar	= 01
0 up to 1 bar	= 02
0 up to 1.6 bar	= 03
0 up to 2.5 bar	= 04
0 up to 4 bar	= 05
0 up to 6 bar	= 06
0 up to 10 bar	= 07
0 up to 16 bar	= 08
0 up to 25 bar	= 09
0 up to 40 bar	= 10
-1 up to 0 bar	= 31
-1 up to 0.6 bar	= 32
-1 up to 1.5 bar	= 33
-1 up to 3 bar	= 34
-1 up to 5 bar	= 35
-1 up to 9 bar	= 36
-1 up to 15 bar	= 37
Pressure connection: G1/2B male threaded stem	G1/2B = 87
Output signal	
4..20 mA 2-wire (ascending characteristic)	= B
Electrical connection	
Terminals	= E
Supply voltage	
DC 15 V up to 30 V	= A
Diaphragm seal	
Without diaphragm seal	= 0
With diaphragm seal	= 1



15.2 Description

The pressure transmitter type ME 49 *****000* is to measure non-flammable media and transmits the pressure signal into an intrinsically safe circuit (4..20 mA current loop).

The pressure transmitter consists of a light metal housing which clearance contains insulating plates with partially casting compound covered electronic components.

Pressure sensors adjusted according to respective application and process connection are inbuilt into the bottom of the housing.

The intrinsically safe supply and signal circuit is wired into the housing and applied to the clamps.

15.3 Parameters

17.3.1 Supply and signal circuit

Voltage	U _i	DC	30	V
Current	I _i		100	mA
Power	P _i		750	mW
Effective internal capacity	C _i		15	nF
Effective internal inductivity	L _i		90	μH
Capacity between circuit and housing			≤ 2.2	nF

17.3.2 Ambient temperature range - 20°C ≤ T_a ≤ +60°C

(16) Test and assessment report
BVS PP 03.2268 EG as of 02.12.2003

(17) Special conditions for safe use
None

We confirm the correctness of the translation from the German original.
In the case of arbitration only the German wording shall be valid and binding.

44809 Bochum, 06.11.2007
BVS-Scha/Ar E 1562/07

DEKRA EXAM GmbH

Certification body

Special services unit



Translation

1st Supplement

(Supplement in accordance with Directive 94/9/EC Annex III number 6)

**to the EC-Type Examination Certificate
BVS 03 ATEX E 414**

Equipment: Pressure transmitter type ME 49 T ** ** *000 R
Manufacturer: Fischer Mess- und Regeltechnik GmbH
Address: 32107 Bad Salzuflen, Germany

Description

The pressure transmitter can be modified according to the descriptive documents as mentioned in the pertinent test and assessment report and shall then be marked as followed:

Pressure transmitter

type ME 49 T ** ** *000 R

Measuring range	
0 up to 40 mbar	= 57
0 up to 60 mbar	= 58
0 up to 100 mbar	= 59
0 up to 160 mbar	= 60
0 up to 250 mbar	= 82
0 up to 400 mbar	= 83
0 up to 0.6 bar	= 01
0 up to 1 bar	= 02
0 up to 1.6 bar	= 03
Output signal	
4..20 mA 2-wire (ascending characteristic)	= B
Electrical connection	
M12 connector plug	= M
Supply voltage	
DC 15 V up to 30 V	= A

The pressure transmitter type ME49T ** ** *000R is to measure flammable media and transmits the pressure signal into an intrinsically safe circuit (4..20 mA current loop).

The pressure transmitter consists of a light metal or chrome-nickel-steel housing which clearance contains insulating plates with partially casting compound covered electronic components.



Pressure sensors adjusted according to respective application and a bubbling-through component (non-electrical) are built into the bottom of the housing. Between the bubbling-through component and the pressure transmitters' electronics a flame arrester is integrated.

The intrinsically safe supply and signal circuit is wired to a connector.

The Essential Health and Safety Requirements of the modified equipment are assured by compliance with:

- EN 50014:1997 + A1 – A2 General requirements
- EN 50020:2002 Intrinsic safety "i"
- EN 50284:1999 Equipment group II, category 1G
- DIN EN 13463-1:2002 Non-electrical equipment part 1: Basic method and requirements with corrigendum 1
- DIN EN 13463-5:2004 Non-electrical equipment part 5: Protection by constructional safety "c"

The marking of the equipment shall include the following:

 II 1/2G EEx ib IIC T6 Pressure transmitter
II 1G c Bubbling-through component (non-electrical)

Parameters

1. Supply and signal circuit (type ME 49 T ** ** *000 R)

Voltage	U_i	DC	30	V
Current	I_i		100	mA
Power	P_i		750	mW
Effective internal capacity	C_i		15	nF
Effective internal inductivity	L_i		90	μ H
Capacity between circuit and housing			\leq 2.2	nF

2. Permitted ambient and medium temperature range

(for electric part):	$-20\text{ °C} \leq T_a \leq +60\text{ °C}$
(for non-electric part):	$-20\text{ °C} \leq T_a \leq +40\text{ °C}$

Special conditions for safe use

None

Test and assessment report

BVS PP 03.2268 EG as of 16. October 2006
BVS PP 1100/108/05 EG as of 18. September 2006

EXAM BBG Prüf- und Zertifizier GmbH
Bochum, dated 16 October 2006

Signed: Dr. Jockers

Signed: Dr. Eickhoff

Certification body

Special services unit



We confirm the correctness of the translation from the German original.
In the case of arbitration only the German wording shall be valid and binding.

44809 Bochum, 06.11.2007
BVS-Scha/Ar E 1562/07

DEKRA EXAM GmbH

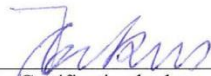

Certification body



Special services unit



Translation
**2nd Supplement to the
EC-Type Examination Certificate**

- (1) **2nd Supplement to the EC-Type Examination Certificate**
- (2) Equipment and protective systems intended for use in potentially explosive atmospheres - Directive 94/9/EC Supplement accordant with Annex III number 6
- (3) No. of EC-Type Examination Certificate: **BVS 03 ATEX E 414**
- (4) Equipment: **Pressure Transmitter type ME 49 F *, type ME 49 T ***
- (5) Manufacturer: **Fischer Mess- und Regeltechnik GmbH**
- (6) Address: **Bielefelder Str. 37a, 32107 Bad Salzufflen, Germany**
- (7) The design and construction of this equipment and any acceptable variation thereto are specified in the appendix to this supplement.
- (8) The certification body of DEKRA EXAM GmbH, notified body no. 0158 in accordance with Article 9 of the Directive 94/9/EC of the European Parliament and the Council of 23 March 1994, certifies that this equipment has been found to comply with the Essential Health and Safety Requirements relating to the design and construction of equipment and protective systems intended for use in potentially explosive atmospheres, given in Annex II to the Directive. The examination and test results are recorded in the Test and Assessment Reports BVS PP 03.2268 EG and PP 1100/108/05 EG.
- (9) The Essential Health and Safety Requirements are assured by compliance with:
 - EN 60079-0:2012 General requirements**
 - EN 60079-11:2012 Intrinsic safety "i"**
 - EN 60079-26:2007 Equipment with equipment protection level (EPL) Ga**
 - DIN EN 13463-1:2009 Non-electrical equipment part 1: Basic method and requirements**
 - DIN EN 13463-5:2011 Non-electrical equipment part 5: Protection by constructional safety "c"**
 - IEC/TS 60079-32-1:2013 Electrostatic hazards, guidance**
- (10) If the sign "X" is placed after the certificate number, it indicates that the equipment is subject to special conditions for safe use specified in the appendix to this certificate.
- (11) This supplement to the EC-Type Examination Certificate relates only to the design, examination and tests of the specified equipment in accordance to Directive 94/9/EC. Further requirements of the Directive apply to the manufacturing process and supply of this equipment. These are not covered by this certificate.
- (12) The marking of the equipment shall include the following:

	II 2G Ex ib IIC T6 Gb	Pressure Transmitter type ME 49 F *
	II 1/2G Ex ib IIC T6 Ga/Gb	Pressure Transmitter type ME 49 T *
	II 1G c	Bubbling-through component of type ME 49 T * (non-electrical)

DEKRA EXAM GmbH
Bochum, dated 2014-09-25

Signed: Simanski

Signed: Dr. Eickhoff

Certification body

Special services unit



- (13) Appendix to
- (14) **2nd Supplement to the EC-Type Examination Certificate
BVS 03 ATEX E 414**

(15) 15.1 Subject and type

Pressure Transmitter type ME 49 F * * * * * 000 *
(Type code: no change)
Pressure Transmitter type ME 49 T * * * * * 000 R
(Type code: no change)

15.2 Description

The Pressure Transmitter can be modified according to the descriptive documents as mentioned in the pertinent test and assessment report
The status of applied standards dealing with the electrical and non-electrical part has been subjected to update.
The construction of the Pressure Transmitter remains unchanged.

15.3 Parameters

No change

(16) Test and Assessment Report

BVS PP 03.2268 EG as of 2014-06-10
BVS PP 1100/108/05 as of 2014-09-23

(17) Special conditions for safe use

None

We confirm the correctness of the translation from the German original.
In the case of arbitration only the German wording shall be valid and binding.

DEKRA EXAM GmbH
44809 Bochum, 2014-09-25
BVS-Scha/Ma A20131192

Certification body

Special services unit



Technische Änderungen vorbehalten • Subject to change without notice • Changements techniques sous réserve