



Data sheet

DE28

Differential pressure transmitter

09005611 • DB_EN_DE28 • Rev. ST4-A • 09/16

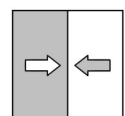

1 Product and functional description

1.1 Performance features

Typical applications

- Differential pressure measurements between the supply and return on heating systems
- Monitoring of filters, fans and compressors
- Ship applications (only DNV GL model)

Important features

- Over-pressure-proof
- Maintenance-free thanks to wear-free "inductive pickup"
- Very versatile
- Sturdy model
- Optionally IP54 or IP65 casing⁽¹⁾
- DNV GL type-tested model in the IP54 casing

1.2 Intended use

The DE28 is a measuring transducer for measuring non-aggressive gas-like and fluid media that is neutral to over-pressure, under-pressure and differential pressure. Always check the media compatibility with the manufacturer if used with potentially aggressive media.

In the standard model, the device is suitable for many measuring tasks in all industrial or sanitary sectors.

The DNV GL type-tested models are suitable for use on ships in machine rooms, control rooms and pump rooms. Please see the following table for details about the application place.

Location classes acc. to DNVGL-CG-0339	
Temperature	B
Humidity	B
Vibration	A
EMC	B
Housing	B

⁽¹⁾ nonly possible in the standard model

1.3 Function diagram

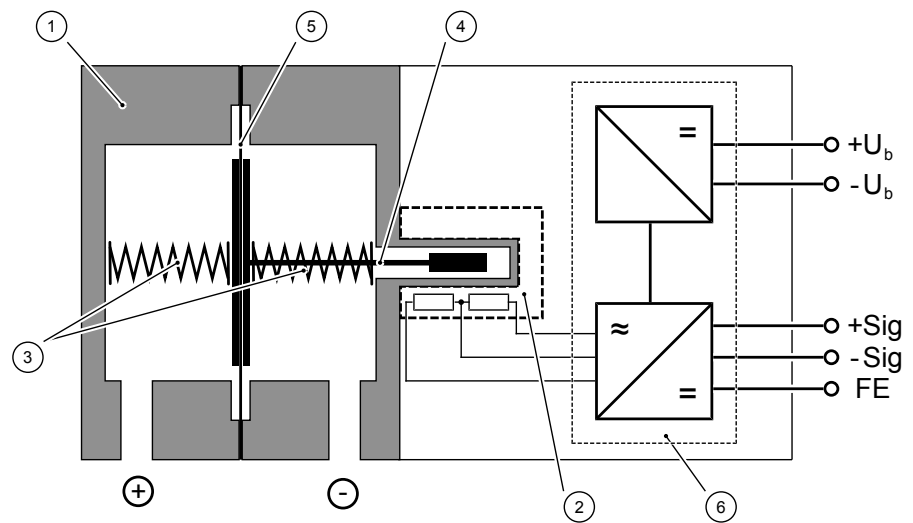

Fig. 1: Function diagram

1	Pressure chamber	2	Inductive displacement transducer
3	Measuring springs	4	Tappet
5	Measuring diaphragm	6	Measuring electronics

1.4 Design and mode of operation

All devices of this type series have a sturdy and non-sensitive membrane measuring unit with an inductive path sensor. All devices work based on the same measuring principle and are suitable for measuring over-pressure, under-pressure and differential pressure.

In the idle position, the spring forces are equalised on both sides of the measuring diaphragm. When pressure is exerted, force is exerted on one side of the membrane and this moves the membrane system against the measuring range springs until the spring forces are compensated.

The movement of the measuring diaphragm is transferred via a tappet into the core of the inductive displacement sensor. The downstream measuring electronics convert the signal of the path sensor into a pressure-proportional unit signal (0...20 mA, 4...20 mA or 0...10 V).

2 Technical Data

2.1 General Information

Reference conditions (acc. to IEC 61298-1)		
Temperature error	+15 ... +25 °C	
Relative humidity	45 ... 75 %	
Air pressure	86 ... 106 kPa	860 ... 1060 mbar
Installation position	User-defined	

2.2 Input variables

Measuring variable

Non-aggressive gas-like and fluid media that is neutral to over-pressure, under-pressure and differential pressure.

Measuring ranges

mbar	bar	kPa
0 ... 400	---	0 ... 40
---	0 ... 0.6	0 ... 60
---	0 ... 1	0 ... 100
---	0 ... 1.6	0 ... 160
---	0 ... 2.5	0 ... 250
---	0 ... 4	0 ... 400
---	0 ... 6	0 ... 600

System pressure	stat. pressure	16 bar
Overload capability	Maximum pressure	16 bar on one side
	min. pressure	Vacuum-proof on both sides
Bursting pressure	±25 bar on both sides	

2.3 Output sizes

	Current output	Voltage output
Output signal	0 ... 20 mA 4 ... 20 mA	0 ... 10 V
Jump response time	approx. 200 ms	approx. 200 ms
Apparent ohmic resistance ^{*)}	≤ 380 Ω	≥ 2 kΩ
Characteristic curve	linear	linear
Connection type	3-Wire	3-Wire

^{*)} regardless of the operating voltage

2.4 Measurement accuracy

Linearity	± 2% of the measuring range span
Hysteresis	± 1% of the measuring range span

2.5 Auxiliary energy

	Current output	Voltage output
Rated Voltage	24 V AC/DC	24 V AC/DC
Admissible operating voltage	20 ... 28 V AC/DC	20 ... 28 V AC/DC
Power consumption	max. 1 W (VA)	max. 0.5 W (VA)

2.6 Application conditions

2.6.1 Devices with IP54 (standard model)

Ambient temperature range	0 °C ... +70 °C
Storage temperature range	0 °C ... +70 °C
Medium temperature range	0 °C ... +70 °C
EMC	EN 61326-1:2013 EN 61326-2-3:2013
EMC-ILA	Version 01-03d
RoHS	EN 50581:2012
Protection class (acc. to EN 60529)	IP54

Materials of the parts that come into contact with the measuring medium

Cutting ring screw connection or screw connection	Nickel-plated brass Aluminium anodised
Measuring system	Brass 2.0401 Stainless steel 1.4310 Mumetall
Membrane	NBR Viton®

Materials of the parts that come into contact with the surroundings

Housing	PA6 GB30
Cable screw connection	PA6
Cable outer jacket	PVC
alternative M12 plug flange casing	PA66

2.6.2 Devices with IP54 (DNV GL model)

Ambient temperature range	+5 °C ... +70 °C
Storage temperature range	0 °C ... +70 °C
Medium temperature range	+5 °C ... +70 °C
DNV GL type testing	acc. to DNVGL-CG-0339
EMC	acc. to DNVGL-CG-0339, Section 3 Class: EMC-B
RoHS	EN 50581:2012
Protection class	in accordance with EN 60529 IP54
	acc. to DNVGL-CG-0339 Class B (IP44)

Materials of the parts that come into contact with the measuring medium

Cutting ring screw connection	Nickel-plated brass
Screw connection	Aluminium anodised
Measuring system	Brass 2.0401 Stainless steel 1.4310 Mumetall
Membrane	NBR Viton®

Materials of the parts that come into contact with the surroundings

Housing	PA6 GB30
Cable screw connection	PA6
Cable outer jacket	Special SABIX SHF 1 mix acc. to IEC 60092-359

2.6.3 Devices with IP65

Ambient temperature range	0°C ... +70 °C
Storage temperature range	0 °C ... +70°C
Medium temperature range	0°C ... +70 °C
EMC	EN 61326-1:2013 EN 61326-2-3:2013
EMC-ILA	Version 01-03d
RoHS	EN 50581:2012
Protection class (acc. to EN 60529)	IP65

Materials of the parts that come into contact with the measuring medium

Cutting ring screw connection	Nickel-plated brass
Screw connection	Aluminium anodised
Measuring system	Brass 2.0401 Stainless steel 1.4310 Mumetall
Membrane	NBR Viton®

Materials of the parts that come into contact with the surroundings

Housing	Grilon® B GK 30 H PA6 glass fibre/glass bead reinforced, heat-stabilised
Wall mounting plate	Aluminium vibration polished
Cable screw connection	PA6
Cable outer jacket	PVC
M12 plug flange casing	PA66

2.7 Construction design

2.7.1 Process connection

All device models are available with the following process connections:

Inner thread	G $\frac{1}{8}$
Cutting ring connection (brass galvanised)	for 3 mm tube
	for 6 mm tube
	for 8 mm tube
Hose screw connection (aluminium anodised)	for 6/4 mm hose
	for 8/6 mm hose

2.7.2 Electrical connection

Devices with IP54 (standard model)

Cable screw connection	M16 x 1.5 mm
Cable diameter	4.5...10 mm
Connection terminal	Screw terminal with wire protection
Connection cross-section	0.5 ... 1.5 mm ² fire-wire with/without ferrules
Option	
Number cable YSLY-JZ 4 x 0.75 mm ² (permanently wired)	1 m
	2.5 m
	5 m
Option	
M12 socket	5-pin male, M12 x 1
M12 connection cable	see accessories

Devices with IP54 (DNV GL model)

Cable screw connection	M16 x 1.5 mm
Number cable SABIX BL 400 FRNC 4 x 0.75 mm ² (permanently wired)	1 m
	2.5 m
	5 m

Devices with IP65

Cable screw connection	M16 x 1.5 mm
Connection terminal	Screw terminal with wire protection
Connection cross-section	0.5 ... 1.5 mm ² fire-wire with/without ferrules
Option	
Number cable YSLY-JZ 4 x 0.75 mm ² (permanently wired)	1 m
	2.5 m
	5 m
Option	
M12 socket	5-pin male, M12 x 1
M12 connection cable	see accessories

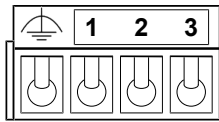

Fig. 2: Connection terminal

Terminal assignment

Numbered cables

Pin	Signal name	Labelling of cables	
	Functional earth		green/yellow
1	Outlet	+Sig	1
2	Supply	-U _b	-Sig 2
3	Supply	+U _b	3

M12 plug

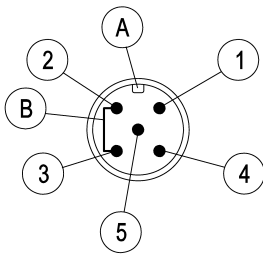

Fig. 3: M12 plug 5-pin+bridge

Pin	Signal name	Labelling of cables	
1	Supply	+U _b	brown
2	Outlet	-Sig	white
3	Supply	-U _b	blue
4	Outlet	+Sig	black
5	Functional earth		green/yellow
A	Coding A		
B	internal bridge		

2.7.3 Dimensional drawings

All dimensions in mm unless otherwise stated

2.7.3.1 IP54 casing

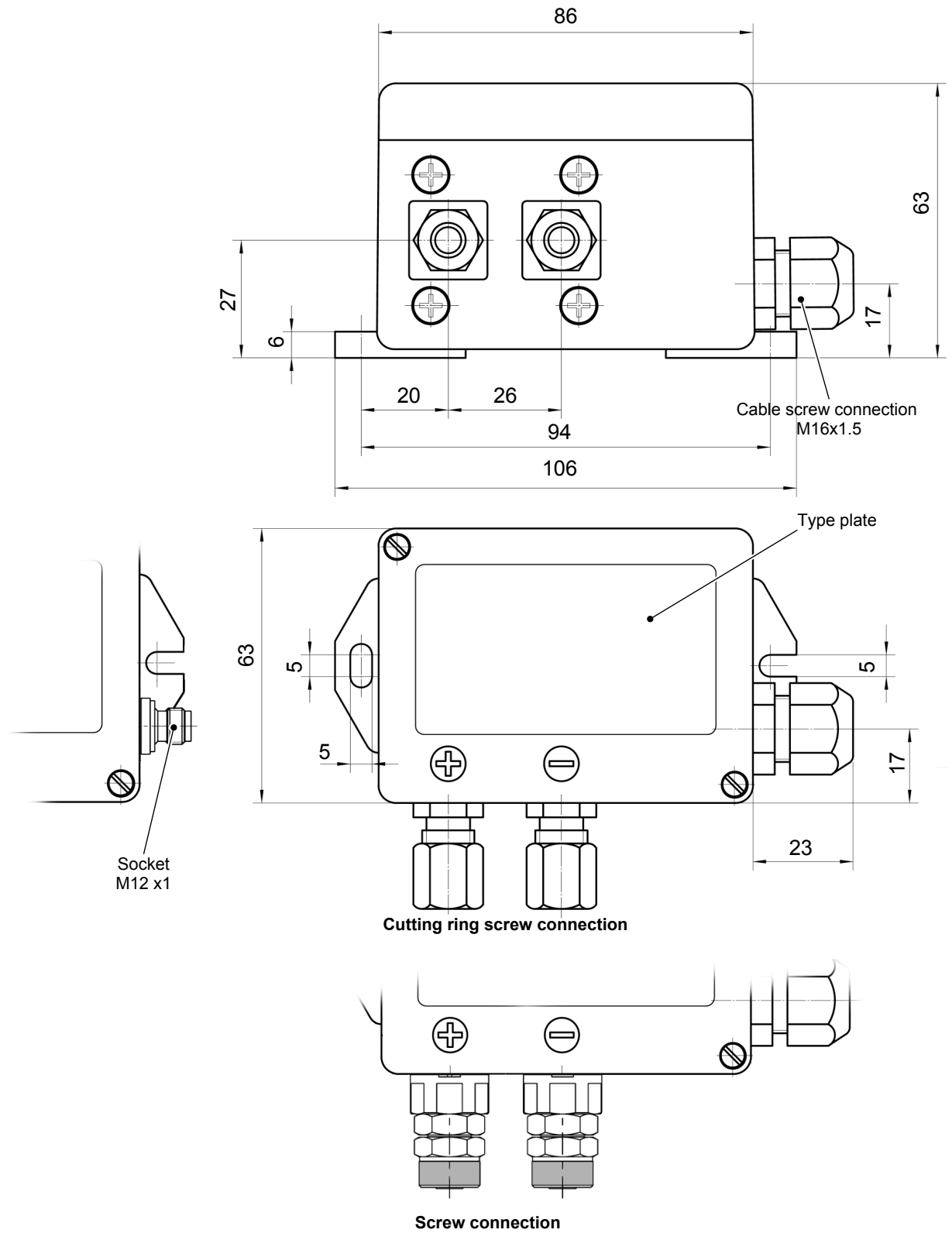

Fig. 4: Dimensional picture IP54 casing

2.7.3.2 IP65 casing

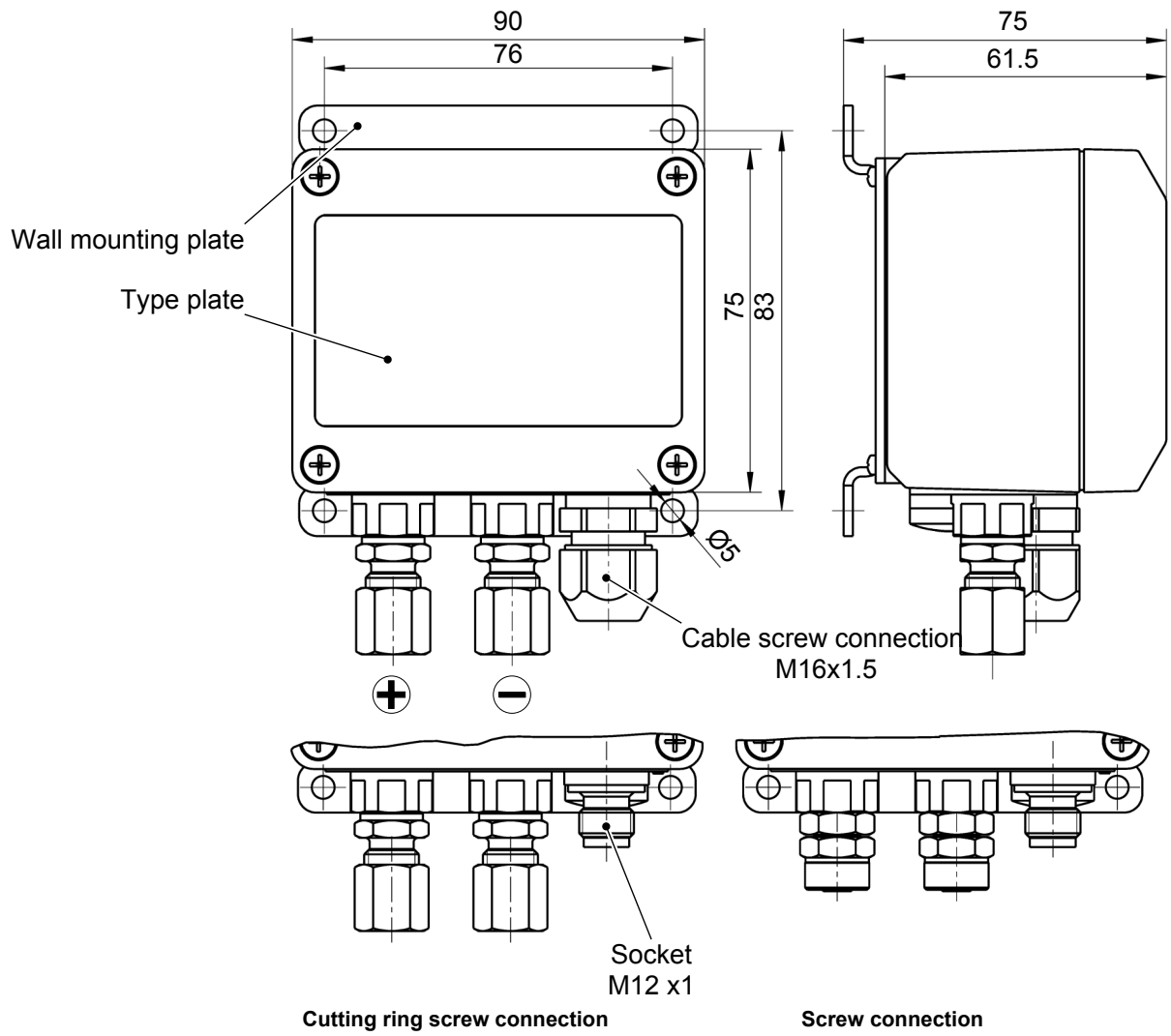
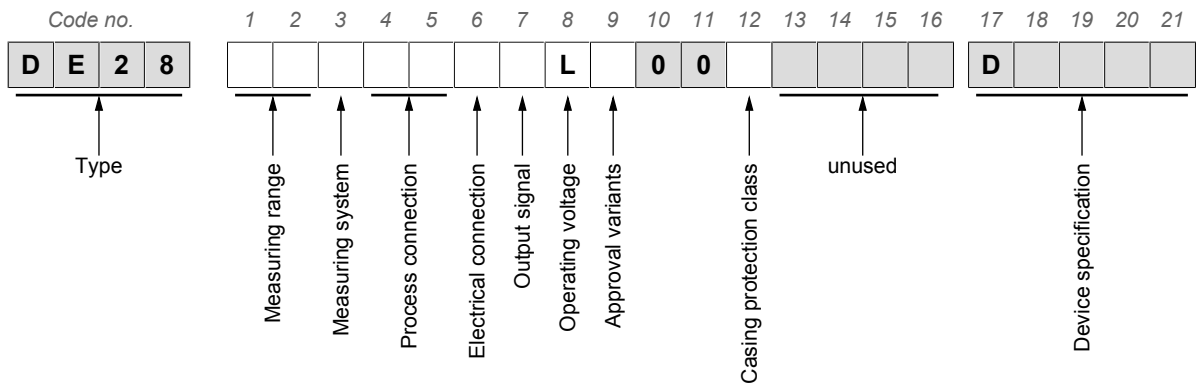

Fig. 5: Dimensional picture IP65 casing

3 Order Codes



Measurement range:

[1.2] (Code no.)	[1.2] (Code no.)
83 0 ... 400 mbar	8E 0 ... 40 kPa
01 0...0.6 bar	F1 0 ... 60 kPa
02 0...1 bar	F2 0 ... 100 kPa
03 0...1.6 bar	F3 0 ... 160 kPa
04 0...2.5 bar	F4 0 ... 250 kPa
05 0...4 bar	F5 0 ... 400 kPa
06 0...6 bar	F6 0 ... 600 kPa

Measuring system:

[3] (Code no.)
M Pressure chamber, membrane, seals: Brass/NBR
N Pressure chamber, membrane, seals: Brass/Viton®

Process connection:

[4.5] (Code no.)
00 Inner thread G 1/8
34 Cutting ring connection brass galvanised for 3 mm pipe
28 Cutting ring connection brass galvanised for 6 mm pipe
29 Cutting ring connection brass galvanised for 8 mm pipe
40 Aluminium hose screw connection anodised for 6/4 mm hose
41 Aluminium hose screw connection anodised for 8/6 mm hose

Electrical connection

[6] (Code no.)
0 Standard model: Cable screw connection M16 x 1.5 ^{*)}
1 1 m numbered cable, permanently wired
2 2.5 m numbered cable, permanently wired
5 5 m numbered cable, permanently wired
M Socket M12 x 1 ^{*)}

^{*)} not possible with DNV GL model

Output signal:

[7] (Code no.)	
A 0 ... 20 mA	3-wire connection
P 4 ... 20 mA	
C 0 ... 10 V DC	

Operating voltage:

[8] (Code no.)
L 24 V AC/DC

Approval variants:

[9] (Code no.)	
0	Standard version
S	DNV GL model

Casing protection class

[12] (Code no.)	
0	IP54
P	IP 65 ^{*)}

^{*)} not possible with DNV GL model

Device specification:

[17-21] (Code no.)	
D####	Model based on customer specification

3.1 Accessories

Order no.	Planned measures	No. of Poles	Length
06401995	Connection cable for supply/signal with M12 connector	5-pin	2 m
06401996	Connection cable for supply/signal with M12 connector	5-pin	5 m
06401564	Connection cable for supply/signal with M12 connector	5-pin	7 m
06401573	Connection cable for supply/signal with M12 connector	5-pin	10 m
064001567	Connection cable for supply/signal with M12 connector	5-pin	15 m
MZ410#	Settable damping reactor		

3.2 Information about the document

This document contains all technical data about the device. Great care was taken when compiling the texts and illustrations; Nevertheless, errors cannot be ruled out.

Subject to technical amendments.

**FISCHER Mess- und Regeltechnik GmbH**

Bielefelder Str. 37a
D-32107 Bad Salzufflen

Tel. +49 5222-974-0

Fax. +49 5222-7170

web : www.fischermesstechnik.de

eMail : info@fischermesstechnik.de