

ROTEX®

Torsionally flexible coupling with T-PUR®

Made for Motion



Table of contents



ROTEX®	
Torsionally flexible coupling	17
Description of coupling	19
Coupling selection	20
Displacements	22
Selection of standard IEC motors	23
Properties of standard spiders	24
Technical data of standard spiders	25
Technical data and properties of special spiders	26
Installation of spider	26
Hub designs	27
Cylindrical bores and spline bores	28
Inch bores and taper bores	29
Shaft coupling - casted materials	30
Shaft coupling - material steel	31
Shaft coupling for taper clamping bushes	32
Clamping ring hubs	33
Clamping hubs	34
Flange programme types AFN and BFN	35
Drop-out center design coupling type A-H	36
NEW Drop-out center design coupling type S-H with SPLIT-hubs	37
Double cardanic type ZS-DKM-H	38
Double cardanic type DKM	39
Intermediate shaft programme type ZR	40
Flange programme types CF, CFN, DF and DFN	41
Type BTAN with brake drum/type SBAN with brake disk	42
Type AFN-SB special with brake disk	43
Type SD (shiftable at standstill)	44
Type FNN and FNN with fan	45
Further types with clamping sets	46
Further types with torque limiter	47
Weights and mass moments of inertia	48

Description of coupling

ROTEX® couplings are characterized by small dimensions, low weight and low mass moments of inertia yet transmit high torques. Running quality and service life of the coupling are improved by accurate all-over machining.

Their application is ideal for transmitting torque while damping torsional vibrations and absorbing shocks produced by the uneven operation of certain prime movers.

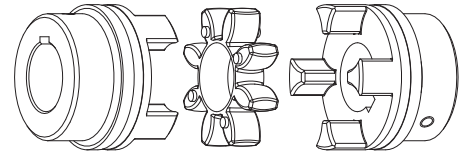

General description

ROTEX® couplings are torsionally flexible and designed for positive torque transmission. They are fail-safe. Operational vibrations and shocks are efficiently dampened and reduced. The two congruent coupling halves with concave claws on the inside are periphally offset in relation to one another by half a pitch. In addition, they are designed in such a way as to enable an involute spider to be located between them.

The teeth of the spider are crowned to avoid edge pressure if the shafts are misaligned. ROTEX® couplings are capable of compensating for axial, radial and angular displacements of the shafts to be connected.

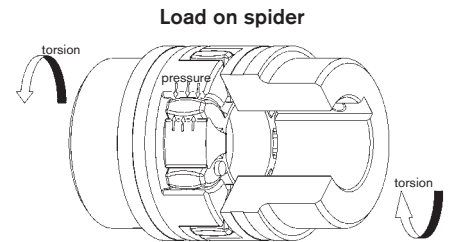

Performance

In contrast to other flexible couplings, the intermediate members of which are subject to bending stress and are therefore prone to earlier wear, the flexible teeth of ROTEX® couplings are subject to pressure only. This gives the additional advantage of the individual teeth being able to accept considerably higher loads. The elastomer parts show deformation with load and excessive speeds. Sufficient space for expansion should be ensured (see drawing – deformation with load).

The maximum torsion angle with ROTEX® couplings of any size amounts to 5°. They can be fitted both horizontally and vertically.

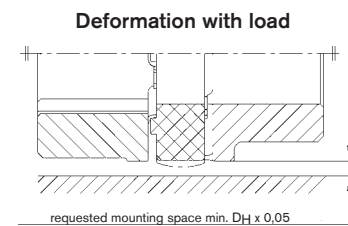

Spiders – our innovation T-PUR®

KTR has developed a new standard material for its spiders. The improved polyurethane material T-PUR® is resistant to significantly higher temperatures and has a considerably longer service life than the previous polyurethane material. From the visual point of view we have characterized the material T-PUR® by the colours orange (92 Shore-A), purple (98 Shore-A) and pale green (64 Shore-D). The previous spiders made of polyurethane in yellow, red and natural white with green ends will still be available.

Up to size ROTEX® 180 inclusive single-parted spiders are used as a standard. Optionally the DZ tooth elements continue to be available for ROTEX® couplings sizes 100-180.

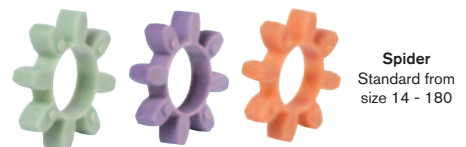

Explosion-proof use

ROTEX® couplings are suitable for power transmission in drives in hazardous areas. The couplings are certified and confirmed according to EC standard 94/9/EC (ATEX 95) as units of category 2G/2D and thus suitable for the use in hazardous areas of zone 1, 2, 21 and 22. Please read through our information included in the respective Type Examination Certificate and the operating and mounting instructions at www.ktr.com.

In addition to the ATEX marking an inspection certificate by DNV, Bureau Veritas or ABS can be ordered for ROTEX® couplings.



Comparison of loads

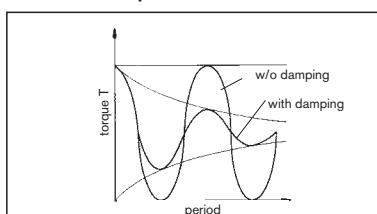

Twisting angle

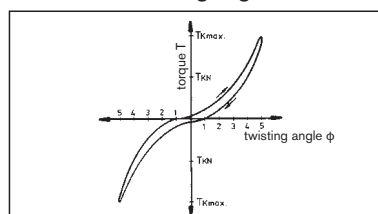

Damping

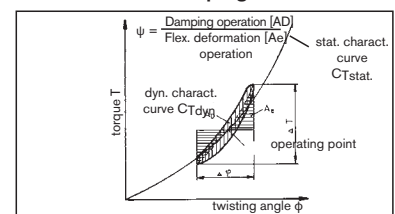

Coupling selection

The ROTEX® coupling is selected in accordance with DIN 740 part 2. The coupling has to be dimensioned in a way that the permissible coupling load is not exceeded in any operating condition. For this purpose the actual loads have to be compared to the permissible parameters of the coupling. The torques T_{KN}/T_{Kmax} mentioned refer to the spider. The shaft-hub-connection has to be investigated by the customer.

1. Drives without periodical torsional vibrations

e. g. centrifugal pumps, fans, screw compressors, etc. The coupling is selected taking into account the rated torques T_{KN} and maximum torque T_{Kmax} .

1.1 Load produced by rated torque

Taking into consideration the ambient temperature, the permissible rated torque T_{KN} of the coupling has to correspond at least to the rated torque T_N of the machine.

$$T_N \text{ [Nm]} = 9550 \cdot P \text{ [kW]} / n \text{ [rpm]}$$

$$T_{KN} \geq T_N \cdot S_t$$

1.2 Load produced by torque shocks

The permissible maximum torque of the coupling has to correspond at least to the total of peak torque T_S and the rated torque T_N of the machine, taking into account the shock frequency Z and the ambient temperature. This applies in case if the rated torque T_N of the machine is at the same time subject to shocks. Knowing the mass distribution, shock direction and shock mode, the peak torque T_S can be calculated. For drives with A. C.-motors with high masses on the load side we would recommend to calculate the peak driving torque with the help of our simulation programme.

$$T_{Kmax} \geq T_S \cdot S_z \cdot S_t + T_N \cdot S_t$$

$$\text{Drive-sided shock} \\ T_S = T_{AS} \cdot M_A \cdot S_A$$

$$\text{Load-sided shock} \\ T_S = T_{LS} \cdot M_L \cdot S_L$$

$$M_A = J_L / (J_A + J_L) \quad M_L = J_A / (J_A + J_L)$$

2. Drives with periodical torsional vibrations

For drives subject to high torsional vibrations, e.g. diesel engines, piston compressors, piston pumps, generators, etc., it is necessary to perform a torsional vibration calculation to ensure a safe operation. If requested, we perform the torsional vibration calculation and the coupling selection in our company. For necessary details please see KTR standard 20004.

2.1 Load produced by rated torque

Taking into account the ambient temperature, the permissible rated torque T_{KN} of the coupling has to correspond at least to the rated torque T_N of the machine.

$$T_{KN} \geq T_N \cdot S_t$$

2.2 Passing through the resonance range

Taking into account the temperature, the peak torque T_S arising when the resonance range is run through must not exceed the maximum torque T_{Kmax} of the coupling.

$$T_{Kmax} \geq T_S \cdot S_t$$

2.3 Load produced by vibratory torque shocks

Taking into account the ambient temperature, the permissible vibratory torque T_{KW} of the coupling must not be exceeded by the highest periodical vibratory torque T_W with operating speed. For higher operating frequencies $f > 10$, the heat produced by damping in the elastomer part is considered as damping power P_W . For higher operating frequencies $f > 10$, the heat produced by damping in the elastomer part is considered as damping power P_W .

$$T_{KW} \geq T_W \cdot S_t$$

$$P_{KW} \geq P_W$$

Description	Symbol	Definition or explanation
Rated torque of coupling	T_{KN}	Torque that can continuously be transmitted over the entire permissible speed range
Maximum torque of coupling	T_{Kmax}	Torque that can be transmitted as dynamic load ≥ 105 times or 5×10^4 as vibratory load, respectively, during the entire operating life of the coupling
Vibratory torque of coupling	T_{KW}	Torque amplitude of the permissible periodical torque fluctuation with a frequency of 10 Hz and a basic load of T_{KN} or dynamic load up to T_{KN} , respectively
Damping power of coupling	P_{KW}	Permissible damping power with an ambient temperature of + 30 °C.
Rated torque of machine	T_N	Stationary rated torque on the coupling
Rated torque of driving side	T_{AN}	Rated torque of machine, calculated from rated power and rated speed
Rated torque of load side	T_{LN}	Maximum figure of the load torque calculated from power and speed
Peak torque of machine	T_S	Peak torque on the coupling
Peak torque on the driving side	T_{AS}	Peak torque with torque shock on the driving side, e. g. breakdown torque of the electric motor

Description	Symbol	Definition or explanation
Peak torque of load side	T_{LS}	Peak torque with torque shock on load side, e. g. braking
Vibratory torque of machine	T_W	Amplitude of the vibratory torque effective on the coupling
Damping power of the machine	P_W	Damping power which is effective on the coupling due to the load produced by the vibratory torque
Moment of inertia of driving side	J_A	Total of moments of inertia existing on the driving or load side referring to the coupling speed
Moment of inertia of load side	J_L	
Rotational inertia coefficient of driving side	M_A	Factor taking into account the mass distribution with shocks and vibrations produced on the driving or load side
Rotational inertia coefficient of load side	M_L	$M_A = J_L / (J_A + J_L) \quad M_L = J_A / (J_A + J_L)$
Screw tightening torque	T_A	Tightening torque of screw

Permissible load on feather key of the coupling hub

Die Welle-Naben-Verbindung ist kundenseitig zu überprüfen. Zulässige Flächenpressung nach DIN 6892 (Methode C)

Cast iron GJL 225 N/mm²
Nodular iron GJS 225 N/mm²
Steel 250 N/mm²

Coupling selection

Service factor temperature S_t											
	-50 °C	-30 °C +30 °C	+40 °C	+50 °C	+60 °C	+70 °C	+80 °C	+90 °C	+100 °C	+110 °C	+120 °C
T-PUR®	1,0	1,0	1,1	1,2	1,3	1,45	1,6	1,8	2,1	2,5	3,0
PUR	-	1,0	1,2	1,3	1,4	1,55	1,8	2,2	-	-	-

For the selection with PEEK spider a temperature factor is not necessary.
For temperature factors for PA spiders see page 26.

Service S_z factor for starting frequency				
starting frequency/h	100	200	400	800
S_z	1,0	1,2	1,4	1,6

Service factor S_A/S_L for shocks	
	S_A/S_L
gentle shocks	1,5
average shocks	1,8
heavy shocks	2,5

Example of calculation of standard IEC motors shown on page 22:

Given: Details of driving side

A. C. motor type: 315 L → $S_A = 1,8$
 Motor output: $P = 160$ kW
 Speed: $n = 1485$ rpm
 Moment of inertia of driving side: $J_A = 2,9$ kgm²
 Start-up frequency: $z = 6$ 1/h → $S_Z = 1,0$
 Ambient temperature: = + 70 °C → $S_t = 1,45$ using T-PUR®

Given: Details of load side

Screw compressor
 Rated torque of load side: $T_{LN} = 930$ Nm
 Moment of inertia of load side: $J_L = 6,8$ kgm²

Calculation

● I Rated driving torque

$$T_{AN} [\text{Nm}] = 9550 \cdot P_{AN} [\text{kW}] / n_{AN} [\text{rpm}]$$

$$T_{AN} [\text{Nm}] = 9550 \cdot 160 [\text{kW}] / 1485 [\text{rpm}] = 1029 \text{ Nm}$$

Coupling selection:

● I Load produced by rated torque

$$T_{KN} \geq T_{LN} \cdot S_t$$

$$T_{KN} \geq 930 \text{ Nm} \cdot 1,5 = 1395 \text{ Nm}$$

Selected:

ROTEX® Size 90 - spider 92 Shore A with:

$T_{KN} = 2400$ Nm
 $T_{K \text{ max.}} = 4800$ Nm

● Load produced by torque shocks

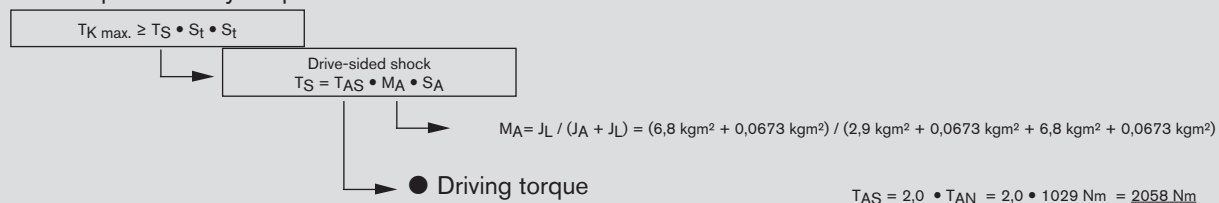

$T_S = 2058 \text{ Nm} \cdot 0,7 \cdot 1,8 = 2593,1 \text{ Nm}$
 $T_{K \text{ max.}} \geq 2593,1 \text{ Nm} \cdot 1 \cdot 1,45 = 3760 \text{ Nm}$
 $T_{K \text{ max.}} \text{ with } 4800 \text{ Nm} \geq 3760 \text{ Nm} \quad \checkmark$

Displacements

Axial displacement ΔK_a

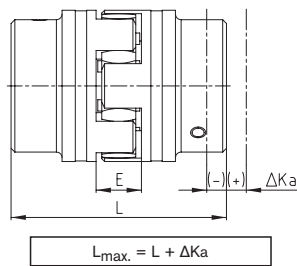

Radial displacement ΔK_r

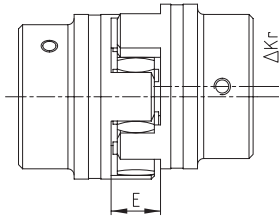

Angular displacement ΔK_w [degrees]

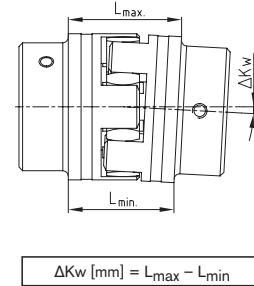

Displacements for spider 92, 95/98 Shore-A

ROTEX® size	14	19	24	28	38	42	48	55	65	75	90	100	110	125	140	160	180
Max. axial displacement ΔK_a [mm]	-0,5 +1,0	-0,5 +1,2	-0,5 +1,4	-0,7 +1,5	-0,7 +1,8	-1,0 +2,0	-1,0 +2,1	-1,0 +2,2	-1,0 +2,6	-1,5 +3,0	-1,5 +3,4	-1,5 +3,8	-2,0 +4,2	-2,0 +4,6	-2,0 +5,0	-2,5 +5,7	-3,0 +6,4
Max. radial displacement with $n=1500$ rpm ΔK_r [mm]	0,17	0,20	0,22	0,25	0,28	0,32	0,36	0,38	0,42	0,48	0,50	0,52	0,55	0,60	0,62	0,64	0,68
Max. angular displacement with $n=1500$ RPM ΔK_w [degree]	1,2	1,2	0,9	0,9	1,0	1,0	1,1	1,1	1,2	1,2	1,2	1,2	1,3	1,3	1,2	1,2	1,2
ΔK_w [mm]	0,67	0,82	0,85	1,05	1,35	1,70	2,00	2,30	2,70	3,30	4,30	4,80	5,60	6,50	6,60	7,60	9,00

Displacements for spider 64 Shore-D

ROTEX® size	14	19	24	28	38	42	48	55	65	75	90	100	110	125	140	160	180
Max. axial displacement ΔK_a [mm]	-0,5 +1,0	-0,5 +1,2	-0,5 +1,4	-0,7 +1,5	-0,7 +1,8	-1,0 +2,0	-1,0 +2,1	-1,0 +2,2	-1,0 +2,6	-1,5 +3,0	-1,5 +3,4	-1,5 +3,8	-2,0 +4,2	-2,0 +4,6	-2,0 +5,0	-2,5 +5,7	-3,0 +6,4
Max. radial displacement with $n=1500$ rpm ΔK_r [mm]	0,11	0,13	0,15	0,18	0,21	0,23	0,25	0,27	0,30	0,34	0,36	0,37	0,40	0,43	0,45	0,46	0,49
Max. angular displacement with $n=1500$ RPM ΔK_w [degree]	1,1	1,1	0,8	0,8	0,9	0,9	1,0	1,0	1,1	1,1	1,1	1,1	1,2	1,2	1,1	1,1	1,1
ΔK_w [mm]	0,57	0,76	0,76	0,90	1,25	1,40	1,80	2,00	2,50	3,00	3,80	4,30	5,30	6,00	6,10	7,10	8,00

Displacements for spider PA, PEEK

ROTEX® size	14	19	24	28	38	42	48	55	65	75	90	100	110	125	140
Max. axial displacement ΔK_a [mm]	-0,5 +1,0	-0,5 +1,2	-0,5 +1,4	-0,7 +1,5	-0,7 +1,8	-1,0 +2,0	-1,0 +2,1	-1,0 +2,2	-1,0 +2,6	-1,5 +3,0	-1,5 +3,4	-1,5 +3,8	-2,0 +4,2	-2,0 +4,6	-2,0 +5,0
Max. radial displacement with $n=1500$ RPM ΔK_r [mm]	0,08	0,10	0,11	0,12	0,14	0,16	0,18	0,19	0,21	0,24	0,25	0,26	0,27	0,30	0,31
Max. angular displacement with $n=1500$ rpm ΔK_w [degree]	0,60	0,45	0,45	0,50	0,50	0,55	0,55	0,55	0,60	0,60	0,60	0,60	0,65	0,65	0,60
ΔK_w [mm]	0,33	0,41	0,42	0,52	0,67	0,85	1,00	1,15	1,35	1,65	2,15	2,40	2,80	3,25	3,30

The above-mentioned figures of displacement of flexible ROTEX® couplings are standard values taking into account the load of the coupling up to the rated torque T_{KN} and an operating speed $n = 1500$ rpm along with an ambient temperature of $+30^\circ\text{C}$.

The displacement figures may only be used individually - if they arise simultaneously, they must be used proportionately. Care should be taken to maintain the distance dimension E accurately in order to allow for axial clearance of the coupling while in operation. Detailed mounting instructions are shown on our homepage (www.ktr.com).

Selection of standard IEC motors

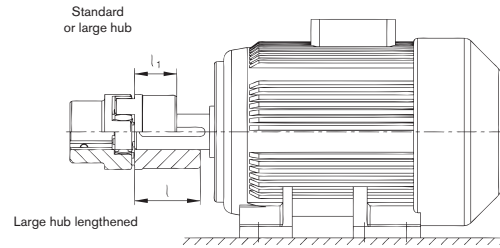



ROTEX® couplings for standard IEC motors, protection class IP 54/IP 55 (spider 92 Shore A)														
A. C. motor 50 Hz		Motor output n = 3000 rpm 2-pole		ROTEX® coupling size	Motor output n = 1500 rpm 4-pole		ROTEX® coupling size	Motor output n = 1000 rpm 6-pole		ROTEX® coupling size	Motor output n = 750 rpm 8-pole		ROTEX® coupling size	
Size	Shaft end d x l [mm]		Output P [kW]		Torque T [Nm]	Output P [kW]		Torque T [Nm]	Output P [kW]		Torque T [Nm]	Output P [kW]		Torque T [Nm]
		2-pole	4, 6, 8 pole											
56	9 x 20		0,09	0,32	9 ¹⁾	0,06	0,43	9 ¹⁾	0,037	0,43	9 ¹⁾			
			0,12	0,41		0,09	0,64		0,045	0,52				
			0,18	0,62		0,12	0,88		0,06	0,7				
63	11 x 23		0,25	0,86	14	0,18	1,3	14	0,09	1,1	14			
			0,37	1,3		0,25	1,8		0,18	2		0,09	1,4	
71	14 x 30		0,55	1,9		0,37	2,5		0,25	2,8		0,12	1,8	
			0,75	2,5		0,55	3,7		0,37	3,9		0,18	2,5	
80	19 x 40		1,1	3,7	19	0,75	5,1	19	0,55	5,8	19	0,25	3,5	
			1,5	5		1,1	7,5		0,75	8		0,37	5,3	
90S	24 x 50		2,2	7,4		1,5	10		1,1	12		0,55	7,9	
90L			3	9,8		2,2	15		1,5	15		0,75	11	
100L	28 x 60		4	13	24	3	20	24	2,2	22	24	1,1	16	
112M			5,5	18		4	27		3	30		1,5	21	
132S	38 x 80		7,5	25	28	5,5	36	28	4	40	28	2,2	30	
132M						7,5	49		5,5	55		3	40	
160M	42 x 110		11	36	38	11	72	38	7,5	75	38	4	54	
			15	49		15	98		11	109		5,5	74	
160L			18,5	60		18,5	121					7,5	100	
180M	48 x 110		22	71		22	144		15	148		11	145	
180L						30	196	42	18,5	181	42	15	198	
200L	55 x 110		37	120	42			42	22	215				
225S	55 x 110	60 x 140				37	240	48				18,5	244	
225M				45	145		45	292		30	293	55	22	290
250M	60 x 140	65 x 140	55	177	48	55	356	55	37	361	55	30	392	
280S		75 x 140	75	241	55	75	484	65 ²⁾	45	438	65 ²⁾	37	483	
280M			90	289		90	581		55	535		45	587	
315S			110	353		110	707	75	75	727	75	55	712	
315M	65 x 140	80 x 170	132	423	65	132	849		90	873		75	971	
				160	513		160	1030		110	1070		90	1170
315L					200	641		200	1290	90	132	1280	90	110
					75				160	1550		132	1710	
315	85 x 170		250	802		250	1600		200	1930		160	2070	
				315	1010		315	2020		250	2410	100	200	2580
				355	1140		355	2280	100					
355	75 x 140	95 x 170	400	1280	90	400	2570		315	3040	110	250	3220	
				500	1600		500	3210	110	400	3850		315	4060
				560	1790		560	3580		450	4330	125	355	4570
400	80 x 170	110 x 210	630	2020		630	4030	125	500	4810		400	5150	
				710	2270	100	710	4540		560	5390	140	450	5790
				800	2560		800	5120	140	630	6060		500	6420
450	90 x 170	120 x 210	900	2880		900	5760		710	6830		560	7190	
				1000	3200	110	1000	6400	160	800	7690	160	630	8090



The arrangement of couplings is valid for an ambient temperature of up to + 30 °C. For the selection there is a minimum safety factor of 2 of the max. coupling torque (TKmax.). A detailed arrangement is possible according to catalogue, page 20 and 21. Drives with periodical torque curves must be selected according to DIN 740 part 2. If requested, KTR will perform the selection. Torque T = rated torque according to Siemens catalogue M 11 · 1994/95..

¹⁾ For dimensions see ROTEX® GS line

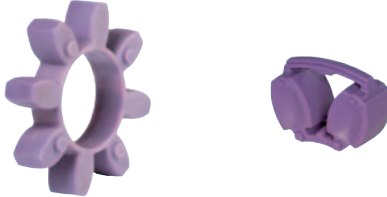

²⁾ Motor hub from steel see page 31

Properties of our standard spiders

Spider type (hardness Shore)	92 Shore-A (T-PUR®)	DZ 92 Shore-A (T-PUR®)	92 Shore-A
	 <p style="text-align: center;">Innovation T-PUR®</p>		
NEW Size	14 to 180	100 to 180	14 to 90
Material	T-PUR®		Polyurethane (PUR)
Perm. temperature range Continuous temperature Max. temperature short time	-50 °C to +120 °C -50 °C to +150 °C		-40 °C to +90 °C -50 °C to +120 °C
Properties	<ul style="list-style-type: none"> - significantly longer service life - very good temperature resistance - improved damping of vibrations - good damping, average elasticity - suitable for all hub materials 		<ul style="list-style-type: none"> - good damping, average elasticity - suitable for all hub materials

Spider type (hardness Shore)	98 Shore-A (T-PUR®) ¹⁾	DZ 95 Shore-A (T-PUR®)	98 Shore-A ¹⁾
	 <p style="text-align: center;">Innovation T-PUR®</p>		
NEW Size	14 to 180	100 to 180	14 to 90
Material	T-PUR®		Polyurethane (PUR)
Perm. temperature range Continuous temperature Max. temperature short time	-50 °C to +120 °C -50 °C to +150 °C		-30 °C to +90 °C -40 °C to +120 °C
Properties	<ul style="list-style-type: none"> - significantly longer service life - very good temperature resistance - improved damping of vibrations - transmission of high torques with average damping - recommended hub material: steel, GJL and GJS 		<ul style="list-style-type: none"> - transmission of high torques with average damping - recommended hub material: steel, GJL and GJS

¹⁾ up to size 65: 95 Sh-A

Spider type (hardness Shore)	64 Shore-D (T-PUR®)	DZ 64 Shore-D (T-PUR®)	64 Shore-D
	 <p style="text-align: center;">Innovation T-PUR®</p>		
NEW Size	14 to 180	100 to 180	14 to 90
Material	T-PUR®		Polyurethane (PUR)
Perm. temperature range Continuous temperature Max. temperature short time	-50 °C to +120 °C -50 °C to +150 °C		-30 °C to +110 °C -30 °C to +130 °C
Properties	<ul style="list-style-type: none"> - significantly longer service life - very good temperature resistance - improved damping of vibrations - transmission of high torques with average damping - recommended hub material: steel, GJL and GJS 		<ul style="list-style-type: none"> - transmission of very high torques with low damping - suitable for displacing critical speeds - resistant to hydrolysis - recommended hub material: steel and GJS

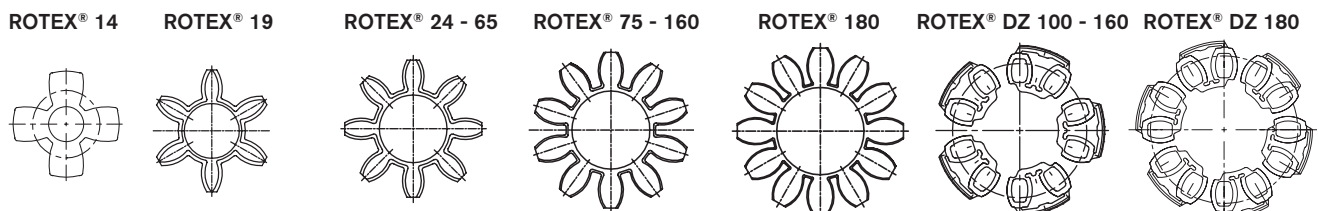

Technical data of our standard spiders

Spider 92 Shore-A made of T-PUR® and PUR														
ROTEX® size	Max. speed		Twist angle φ with		Torque [Nm]			Damping power P _{KW} [W] ¹⁾	Relative damping ψ	Resonance factor V _R	Torsion spring stiffness C dyn. [Nm/rad]			
	V=35 m/s cast iron	V=40 m/s steel	T _{KN}	T _{K max}	Rated (T _{KN})	Max (T _{K max})	Vibratory (T _{KW})				1,0 T _{KN}	0,75 T _{KN}	0,5 T _{KN}	0,25 T _{KN}
14	22200	25400	6,4°	10°	7,5	15	2,0	–			0,38x10 ³	0,31x10 ³	0,24x10 ³	0,14x10 ³
19	16700	19000			10	20	2,6	4,8			1,28x10 ³	1,05x10 ³	0,80x10 ³	0,47x10 ³
24	12100	13800			35	70	9,1	6,6			4,86x10 ³	3,98x10 ³	3,01x10 ³	1,79x10 ³
28	10100	11500			95	190	25	8,4			10,90x10 ³	8,94x10 ³	6,76x10 ³	4,01x10 ³
38	8300	9500			190	380	49	10,2			21,05x10 ³	17,26x10 ³	13,05x10 ³	7,74x10 ³
42	7000	8000			265	530	69	12,0			23,74x10 ³	19,47x10 ³	14,72x10 ³	8,73x10 ³
48	6350	7250			310	620	81	13,8			36,70x10 ³	30,09x10 ³	22,75x10 ³	13,49x10 ³
55	5550	6350			410	820	107	15,6			50,72x10 ³	41,59x10 ³	31,45x10 ³	18,64x10 ³
65	4950	5650	3,2°	5°	625	1250	163	18,0	0,80	7,90	97,13x10 ³	79,65x10 ³	60,22x10 ³	35,70x10 ³
75	4150	4750			1280	2560	333	21,6			113,32x10 ³	92,92x10 ³	70,26x10 ³	41,65x10 ³
90	3300	3800			2400	4800	624	30,0			190,09x10 ³	155,87x10 ³	117,86x10 ³	69,86x10 ³
100	2950	3350			3300	6600	858	36,0			253,08x10 ³	207,53x10 ³	156,91x10 ³	93,01x10 ³
110	2600	2950			4800	9600	1248	42,0			311,61x10 ³	255,52x10 ³	193,20x10 ³	114,52x10 ³
125	2300	2600			6650	13300	1729	48,0			474,86x10 ³	389,39x10 ³	294,41x10 ³	174,51x10 ³
140	2050	2350			8550	17100	2223	54,6			660,49x10 ³	541,60x10 ³	409,50x10 ³	242,73x10 ³
160	1800	2050			12800	25600	3328	75,0			890,36x10 ³	730,10x10 ³	552,03x10 ³	327,21x10 ³
180	1550	1800			18650	37300	4849	78,0			2568,56x10 ³	2106,22x10 ³	1592,51x10 ³	943,95x10 ³

95/98 Shore-A spider made of T-PUR® and PUR ²⁾														
ROTEX® size	Max. speed		Twist angle φ with		Torque [Nm]			Damping power P _{KW} [W] ¹⁾	Relative damping ψ	Resonance factor V _R	Torsion spring stiffness C dyn. [Nm/rad]			
	V=35 m/s iron	V=40 m/s steel	T _{KN}	T _{K max}	Rated (T _{KN})	Max (T _{K max})	Vibratory (T _{KW})				1,0 T _{KN}	0,75 T _{KN}	0,5 T _{KN}	0,25 T _{KN}
14	22200	25400	6,4°	10°	12,5	25	3,3	–			0,56x10 ³	0,46x10 ³	0,35x10 ³	0,21x10 ³
19	16700	19000			17	34	4,4	4,8			2,92x10 ³	2,39x10 ³	1,81x10 ³	1,07x10 ³
24	12100	13800			60	120	16	6,6			9,93x10 ³	8,14x10 ³	6,16x10 ³	3,65x10 ³
28	10100	11500			160	320	42	8,4			26,77x10 ³	21,95x10 ³	16,60x10 ³	9,84x10 ³
38	8300	9500			325	650	85	10,2			48,57x10 ³	39,83x10 ³	30,11x10 ³	17,85x10 ³
42	7000	8000			450	900	117	12,0			54,50x10 ³	44,69x10 ³	33,79x10 ³	20,03x10 ³
48	6350	7250			525	1050	137	13,8			65,29x10 ³	53,54x10 ³	40,48x10 ³	24,00x10 ³
55	5550	6350			685	1370	178	15,6			94,97x10 ³	77,88x10 ³	58,88x10 ³	34,90x10 ³
65	4950	5650	3,2°	5°	940	1880	244	18,0	0,80	7,90	129,51x10 ³	106,20x10 ³	80,30x10 ³	47,60x10 ³
75	4150	4750			1920	3840	499	21,6			197,50x10 ³	161,95x10 ³	122,45x10 ³	72,58x10 ³
90	3300	3800			3600	7200	936	30,0			312,20x10 ³	256,00x10 ³	193,56x10 ³	114,73x10 ³
100	2950	3350			4950	9900	1287	36,0			383,26x10 ³	314,27x10 ³	237,62x10 ³	140,85x10 ³
110	2600	2950			7200	14400	1872	42,0			690,06x10 ³	565,85x10 ³	427,84x10 ³	253,60x10 ³
125	2300	2600			10000	20000	2600	48,0			1343,64x10 ³	1101,79x10 ³	833,06x10 ³	493,79x10 ³
140	2050	2350			12800	25600	3328	54,6			1424,58x10 ³	1168,16x10 ³	883,24x10 ³	523,54x10 ³
160	1800	2050			19200	38400	4992	75,0			2482,23x10 ³	2035,43x10 ³	1538,98x10 ³	912,22x10 ³
180	1550	1800			28000	56000	7280	78,0			3561,45x10 ³	2920,40x10 ³	2208,10x10 ³	1308,84x10 ³



Spider 64 Shore-D made of T-PUR® and PUR														
ROTEX® size	Max. speed		Twist angle φ with		Torque [Nm]			Damping power P _{KW} [W] ¹⁾	Relative damping ψ	Resonance factor V _R	Torsion spring stiffness C dyn. [Nm/rad]			
	V=35 m/s iron	V=40 m/s steel	T _{KN}	T _{K max}	Rated (T _{KN})	Max (T _{K max})	Vibratory (T _{KW})				1,0 T _{KN}	0,75 T _{KN}	0,5 T _{KN}	0,25 T _{KN}
14	22200	25400	4,5°	7,0°	16	32	4,2	9,0			0,76x10 ³	0,62x10 ³	0,47x10 ³	0,28x10 ³
19	16700	19000			21	42	5,5	7,2			5,35x10 ³	4,39x10 ³	3,32x10 ³	1,97x10 ³
24	12100	13800			75	150	19,5	9,9			15,11x10 ³	12,39x10 ³	9,37x10 ³	5,55x10 ³
28	10100	11500			200	400	52	12,6			27,52x10 ³	22,57x10 ³	17,06x10 ³	10,12x10 ³
38	8300	9500			405	810	105	15,3			70,15x10 ³	57,52x10 ³	43,49x10 ³	25,78x10 ³
42	7000	8000			560	1120	146	18,0			79,86x10 ³	65,49x10 ³	49,52x10 ³	29,35x10 ³
48	6350	7250			655	1310	170	20,7			95,51x10 ³	78,32x10 ³	59,22x10 ³	35,10x10 ³
55	5550	6350			825	1650	215	23,4			107,92x10 ³	88,50x10 ³	66,91x10 ³	39,66x10 ³
65	4950	5650	2,5°	3,6°	1175	2350	306	27,0	0,75	8,50	151,09x10 ³	123,90x10 ³	93,68x10 ³	55,53x10 ³
75	4150	4750			2400	4800	624	32,4			248,22x10 ³	203,54x10 ³	153,90x10 ³	91,22x10 ³
90	3300	3800			4500	9000	1170	45,0			674,52x10 ³	553,11x10 ³	418,20x10 ³	247,89x10 ³
100	2950	3350			6185	12370	1608	54,0			861,17x10 ³	706,16x10 ³	533,93x10 ³	316,48x10 ³
110	2600	2950			9000	18000	2340	63,0			1138,59x10 ³	933,64x10 ³	705,92x10 ³	418,43x10 ³
125	2300	2600			12500	25000	3250	72,0			1435,38x10 ³	1177,01x10 ³	889,93x10 ³	527,50x10 ³
140	2050	2350			16000	32000	4160	81,9			1780,73x10 ³	1460,20x10 ³	1104,05x10 ³	654,42x10 ³
160	1800	2050			24000	48000	6240	112,5			3075,80x10 ³	2522,16x10 ³	1907,00x10 ³	1130,36x10 ³
180	1550	1800			35000	70000	9100	117,0			6011,30x10 ³	4929,27x10 ³	3727,01x10 ³	2209,15x10 ³

Temperature factor S _t											
	-50 °C	-30 °C +30 °C	+40 °C	+50 °C	+60 °C	+70 °C	+80 °C	+90 °C	+100 °C	+110 °C	+120 °C
T-PUR®	1,0	1,0	1,1	1,2	1,3	1,45	1,6	1,8	2,1	2,5	3,0
PUR	–	1,0	1,2	1,3	1,4	1,55	1,8	2,2	–	–	–

Unless explicitly specified in your order, we will supply spiders with Shore hardness 92 Sh-A T-PUR®.
For circumferential speeds exceeding V = 30 m/s dynamic balancing is necessary. For circumferential speeds exceeding V = 35 m/s only steel or nodular iron.

¹⁾ with +30 °C
²⁾ up to size 65: 95Sh-A

Technical data and properties of the special spiders

		
Spider type	PA	PEEK
Material	Polyamide	Polyetheretherketone
Perm. temperature range Continuous temperature Max. temperature short time	-20 °C to +130 °C ¹⁾ -30 °C to +150 °C ¹⁾	up to +180 °C (ATEX to +160 °C) up to +250 °C
Properties	<ul style="list-style-type: none"> - low twisting angles and high torsion spring stiffness - transmission of very high torques with very low damping - good resistance to chemicals ¹⁾ - recommended hub material: steel - high restoring forces with displacements 	<ul style="list-style-type: none"> - low twisting angle and high torsion spring stiffness - transmission of very high torques with very low damping - highly temperature-resistant, resistant to hydrolysis - good resistance to chemicals - recommended hub material: steel - high restoring forces with displacements

¹⁾ Different properties depending on compound

Torques			
	PA, PEEK		
	T _{KN} [Nm]	T _{K max} [Nm]	T _{KW} [Nm]
14	22	44	5,5
19	30	60	8,0
24	105	210	27,5
28	280	560	73
38	565	1130	147
42	785	1570	204
48	915	1830	238
55	1200	2400	312
65	1645	3290	427
75	2560	5130	667
90	6300	12600	1640
100	8650	17300	2250
110	10500	21000	2730
125	13000	26000	3380

Service factor temperature S _t												
	-50 °C	-30 °C +30 °C	+40 °C	+50 °C	+60 °C	+70 °C	+80 °C	+90 °C	+100 °C	+110 °C	+120 °C	+180 °C
PA	-	1,0	1,15	1,25	1,4	1,6	1,9	2,3	3,0	-	-	-
PEEK	-	1,0	1,0	1,0	1,0	1,0	1,0	1,0	1,0	1,0	1,0	1,0

Installation of spider

Shaft $\varnothing d_{VW}$ with feather key (acc. to DIN 6885 sh.1) protruding into the spider $\varnothing d_H$

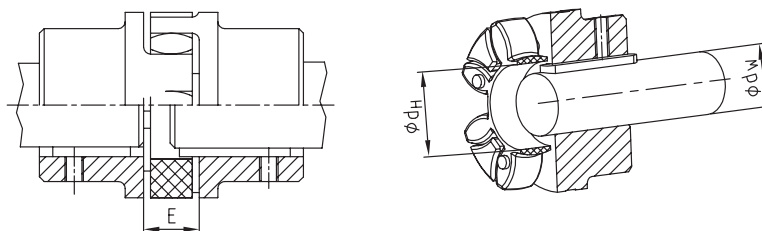

Mounting dimension																	
ROTEX® size	14	19	24	28	38	42	48	55	65	75	90	100	110	125	140	160	180
Distance dimension E	13	16	18	20	24	26	28	30	35	40	45	50	55	60	65	75	85
Dimension d _H	10	18	27	30	38	46	51	60	68	80	100	113	127	147	165	190	220
Dimension d _{VW} ²⁾	7	12	20	22	28	36	40	48	55	65	80	95	100	120	135	160	185

²⁾ If the shaft diameter is smaller than or corresponds to the dimension d_H, one shaft end or both shaft ends may protrude with the feather key in the spider.

Hub designs

Due to the numerous applications of ROTEX® for many different applications and mounting situations, this coupling system is available with various hub designs. These designs mainly differ in that they offer either positive or frictionally engaged connections, but mounting situations like, for example, gear shafts with integrated transmission cams or similar applications are covered, too.

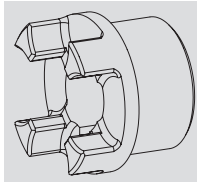

Design 1.0 hub with keyway and fixing screw

Positive locking power transmission, permissible torque depending on the permissible surface pressure. Not suitable for backlash-free power transmission with heavily reversing operation.

Design 1.1 hub without keyway, with fixing screw

Non-positive torque transmission for crimp and glued connections.

Design 1.3 hub spline bore (see page 28)

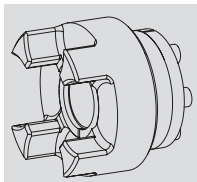

Design 4.2 with CLAMPEX® clamping set KTR 250

Frictionally engaged, backlash-free shaft-hub-connection for the transmission of average torques.

Design 4.1 for CLAMPEX® clamping set KTR 200

Design 4.3 for CLAMPEX® clamping set KTR 400

Frictionally engaged, backlash-free shaft-hub-connection for the transmission of high torques.

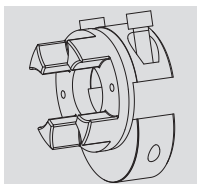

Design 7.5 clamping hub type DH without feather keyway for double-cardanic connection

Frictionally engaged, backlash-free shaft-hub-connection for radial assembly of coupling. Transmittable torques depending on bore diameter (for ATEX category 3 only)

Design 7.6 clamping hub type DH with feather keyway for double-cardanic connection

Positive locking power transmission with additional frictionally engaged condition for radial assembly of coupling. The frictionally engaged condition prevents or reduces reverse backlash, respectively. Surface pressure of the feather key connection is reduced.

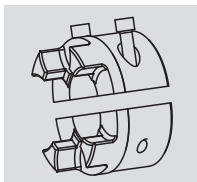

Design 7.0 split hub without feather keyway

Split hub made of cast iron. Frictionally engaged, backlash-free shaft-hub-connection. Transmittable torques depending on bore diameter (For ATEX category 3 only)

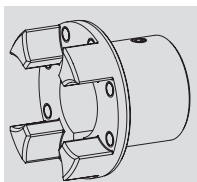

FNN hub

Coupling hub to be connected to an attachment such as brake drum, brake disk and fan.

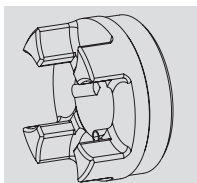

TB1 hub/TB2 hub

Coupling hub for taper clamping bushes. TB1 screwed on cam side. TB2 screwed externally.

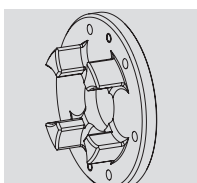

Driving flange design 3b

Driving flange to connect to customer's component. For dimensions see page 41

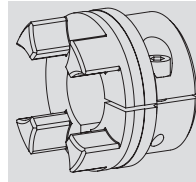

Design 2.0 clamping hub, single slotted, without keyway

Frictionally engaged, backlash-free shaft-hub-connection. Transmittable torques depending on bore diameter (see page 34). (For ATEX category 3 only).

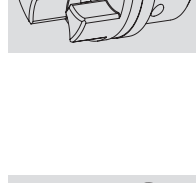

Design 2.1 clamping hub, single slotted, with keyway

Positive locking power transmission with additional frictionally engaged condition. The frictionally engaged condition prevents or reduces reverse backlash, respectively. Surface pressure of the feather key connection is prevented.

Design 2.3 clamping hub with spline bore (see page 28/34)

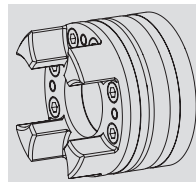

Design 6.0 clamping ring hub (see ROTEX® GS series)

Integrated frictionally engaged shaft-hub-connection for the transmission of higher torques. Screwing on elastomer side. For details about torque and dimensions see page 33. Suitable for high speeds.

Design 6.5 clamping ring hub (see ROTEX® GS series)

Design like 6.0, except for clamping screws externally. As an example for radial disassembly of intermediate pipe (special design).

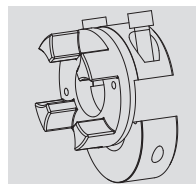

Design 7.8 clamping hub type H without feather keyway

Frictionally engaged, backlash-free shaft-hub-connection for radial assembly of coupling. Transmittable torques depend on the bore diameter (for ATEX category 3 only).

Design 7.9 clamping hub type H with feather keyway

Positive locking power transmission with additional friction fit for radial assembly of coupling. The frictionally engaged condition prevents or reduces reverse backlash, respectively. Surface pressure of the feather key connection is prevented.

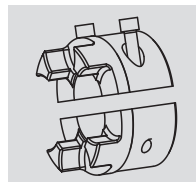

Design 7.1 split hub with feather keyway

Split hub made of cast iron. Positive locking power transmission with additional frictionally engaged condition. The frictionally engaged condition prevents or reduces reverse backlash, respectively. The surface pressure of the feather key connection is reduced.

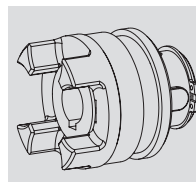

SD hub shifting hub

Coupling hub for separating or switching on the driving/driven machine with standstill of the machine. Can be combined with slip ring and shiftable linkage.

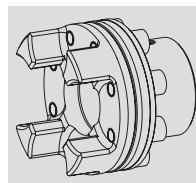

Design 3Na + 4N Driving flange with C-flange

For type AFN and BFN. With type AFN the spider can be replaced while being assembled without having to disassemble the driving and driven side.

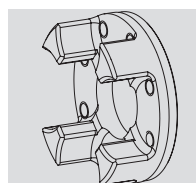

Driving flange design 3Na

Driving flange to connect to customer's component. For dimensions see page 41.

Cylindrical bores and spline bores

ROTEX® Size/material		un- bo- red	Ø6	Ø8	Ø9	Ø10	Ø11	Ø12	Ø14	Ø15	Ø16	Ø17	Ø18	Ø19	Ø20	Ø22	Ø24	Ø25	Ø28	Ø30	Ø32	Ø35	Ø38	Ø40	Ø42	Ø45	Ø48	Ø50	Ø55	Ø60	Ø65	Ø70	Ø75	Ø80	Ø85	Ø90	Ø100		
14	Sint	●		●		●	●	●	●																														
	Al-H	●	●	●	●	●	●	●	●	●	●																												
19	Sint	●								●	●																												
	Al-D	●		●		●	●	●	●	●	●	●	●	●	●	●	●	●	●																				
24	St	●		●		●	●	●	●	●	●	●	●	●	●	●	●	●	●																				
	Al-D	●			●	●	●	●	●	●	●	●	●	●	●	●	●	●	●	●																			
28	St	●			●	●	●	●	●	●	●	●	●	●	●	●	●	●	●	●																			
	Al-D	●				●	●	●	●	●	●	●	●	●	●	●	●	●	●	●	●																		
38	GJL	●								●	●	●	●	●	●	●	●	●	●	●	●	●	●	●	●	●	●	●	●	●	●	●	●	●	●	●	●	●	
	St	●									●	●	●	●	●	●	●	●	●	●	●	●	●	●	●	●	●	●	●	●	●	●	●	●	●	●	●	●	
42	GJL	●														●	●	●	●	●	●	●	●	●	●	●	●	●	●	●	●	●	●	●	●	●	●	●	
	St	●															●	●	●	●	●	●	●	●	●	●	●	●	●	●	●	●	●	●	●	●	●	●	
48	GJL	●															●	●	●	●	●	●	●	●	●	●	●	●	●	●	●	●	●	●	●	●	●	●	
	St	●																●	●	●	●	●	●	●	●	●	●	●	●	●	●	●	●	●	●	●	●	●	
55	GJL	●																●	●	●	●	●	●	●	●	●	●	●	●	●	●	●	●	●	●	●	●	●	
	St	●																	●	●	●	●	●	●	●	●	●	●	●	●	●	●	●	●	●	●	●	●	
65	GJL	●																		●	●	●	●	●	●	●	●	●	●	●	●	●	●	●	●	●	●	●	
	St	●																			●	●	●	●	●	●	●	●	●	●	●	●	●	●	●	●	●	●	
75	GJL	●																			●	●	●	●	●	●	●	●	●	●	●	●	●	●	●	●	●		
	St	●																				●	●	●	●	●	●	●	●	●	●	●	●	●	●	●	●		
90	GJL	●																								●	●	●	●	●	●	●	●	●	●	●	●	●	
	St	●																									●	●	●	●	●	●	●	●	●	●	●	●	

Basic programme SAE involute spline											
Spline code	Size	Pitch circle	Pitch	No. of teeth	Angle	Spline code	Size	Pitch circle	Pitch	No. of teeth	Angle
PH-S	5/8"	14,28	16/32	9	30°	PS-S	1 1/2"	35,98	12/24	17	30°
PI-S	3/4"	17,46	16/32	11	30°	PD-S	1 1/2"	36,51	16/32	23	30°
PB-S	7/8"	20,63	16/32	13	30°	PE-S	1 3/4"	42,86	16/32	27	30°
PB-BS	1"	23,81	16/32	15	30°	PK	1 3/4"	41,275	8/16	13	30°
PJ	1 1/8"	26,98	16/32	17	30°	PT-C ¹⁾	2"	47,625	8/16	15	30°
PC-S	1 1/4"	29,63	12/24	14	30°	PQ-C ¹⁾	2 1/4"	53,975	8/16	17	30°
PA-S	1 3/8"	33,33	16/32	21	30°						

Basic programme spline bores to DIN 5482										
Size	Pitch circle	Pitch	No. of teeth	Profile correction	Size	Pitch circle	Pitch	No. of teeth	Profile correction	
A 17 x 14	14,40	1,6	9	+0,600 ²⁾	A 35 x 31	31,50	1,75	18	+0,676	
A 20 x 17	19,20	1,6	12	-0,2	A 40 x 36	38,00	1,9	20	+0,049	
A 25 x 22	22,40	1,6	14	+0,550	A 45 x 41	44,00	2	22	+0,181	
A 28 x 25	26,25	1,75	15	+0,302	A 50 x 45	48,00	2	24	+0,181	
A 30 x 27	28,00	1,75	16	+0,327						

Basic programme spline bores to DIN 5480							
Spline code	Pitch circle	Pitch	No. of teeth	Spline code	Pitch circle	Pitch	No. of teeth
20 x 1 x 18 x 7H	18,0	1	18	40 x 2 x 18 x 8H	36,0	2	18
20 x 1,25 x 14 x 7H	17,5	1,25	14	45 x 2 x 21 x 7H	41,0	2	21
25 x 1,25 x 18 x 7H	22,5	1,25	18	48 x 2 x 22 x 9H	44,0	2	22
28 x 1,25 x 21 x 7H	26,25	1,25	21	50 x 2 x 24 x 8H	48,0	2	24
30 x 2 x 14 x 7H	26,0	2	14	60 x 2 x 28 x 8H	56,0	2	28
32 x 2 x 14 x 8H	28,0	2	14	75 x 3 x 24 x 7H	72,0	3	24
35 x 2 x 16 x 8H	32,0	2	16	80 x 3 x 25 x 8H	75,0	3	25

Basic programme spline bores to DIN 9611				
Size	Width of keyway	No. of teeth	Tip circle	Root circle
1 3/8"	8,69	6	34,93	29,65

Spline clamping hubs are often adapted to the shafts of hydraulic pumps/hydraulic motors. Please ask us about the corresponding hub length of the spline code!

¹⁾ For clamping hubs only, for plug-in hubs use code PT or PQ.

²⁾ Profile correction different from DIN

Inch bores and taper bores

ROTEX® size					Stock programme inch bores										
Material					19	24	28	38	42	48	55	65	75	90	
Code	Ød	Ød Inch	b ^{+0.05}	t ₂ ^{+0.2}	St	St	St	GJL	GJL	GJL	GJL	GJL	GJL	GJL	
Tb	9,5 ^{+0.03}	3/8	3,17	11,1											
DNB	11,11 ^{M7}	7/16	2,4	12,5											
T	12,69 ^{H7}	1/2	4,75	14,6											
Ta	12,7 ^{+0.03}	1/2	3,17	14,3	●	●									
DNC	3,45 ^{H7}	17/32	3,17	14,9											
Do	14,29 ^{+0.03}	9/16	3,17	15,6											
E	15,87 ^{+0.03}	5/8	3,17	17,5											
Es	15,88 ^{+0.03}	5/8	4,00	17,7	●	●	●								
Ed	15,87 ^{+0.03}	5/8	4,75	18,1	●	●									
DNH	17,465 ^{H7}	11/16	4,75	19,6											
Ad	19,02 ^{+0.03}	3/4	3,17	20,7											
A	19,05 ^{+0.03}	3/4	4,78	21,3	●	●	●	●							
Gs	22,22 ^{+0.03}	7/8	4,78	24,4	●										
G	22,22 ^{+0.03}	7/8	4,75	4,7	●	●	●	●	●						
F	22,22 ^{+0.03}	7/8	6,38	25,2		●	●	●	●	●					
Gd	22,225 ^{M7}	7/8	4,76	24,7		●									
Gf	23,80 ^{+0.03}	15/16	6,35	26,8											
Bs	25,38 ^{+0.03}	1	6,37	28,3		●	●	●	●						
H	25,40 ^{+0.03}	1	4,78	27,8											
Hs	25,40 ^{+0.03}	1	6,35	28,7											
R	26,95 ^{+0.03}	1 1/16	4,78	29,3			●								
Sa	28,575 ^{M7}	1 1/8	6,35	31,7		●	●								
Sb	28,58+0,03	1 1/8	6,35	31,5			●	●							
Sd	28,58 ^{+0.03}	1 1/8	7,93	32,1											
Js	31,75 ^{+0.03}	1 1/4	6,35	34,6											
K	31,75 ^{K7}	1 1/4	7,93	35,5			●	●	●	●	●	●	●	●	
Ma	34,925 ^{M7}	1 3/8	7,93	38,7			●								
RH1	34,93 ^{M7}	1 3/8	9,55	37,8											
Cb	36,50 ^{+0.03}	1 7/16	9,55	40,9											
Ca	38,07 ^{+0.03}	1 1/2	7,93	42,0											
C	38,07 ^{+0.03}	1 1/2	9,55	42,5			●	●	●	●	●	●	●	●	
Nb	41,275 ^{M7}	1 5/8	9,55	45,8				●	●						
Ls	44,42 ^{+0.03}	1 3/4	9,55	48,8											
L	44,45 ^{K7}	1 3/4	11,11	49,4											
Lu	47,625 ^{M7}	1 7/8	12,7	53,5				●							
Da	49,20 ^{+0.03}	1 15/16	12,7	55,0											
Ds	50,77 ^{+0.03}	2	12,7	56,4											
D	50,80 ^{+0.03}	2	12,7	55,1											
Pa	53,975 ^{M7}	2 1/8	12,7	60,0								●			
U	57,10 ^{+0.03}	2 1/4	12,7	62,9											
Ub	60,325 ^{M7}	2 3/8	15,875	67,6											
Wd	85,725 ^{M7}	3 3/8	22,225	95,8											
Wf	92,075 ^{M7}	3 5/8	22,225	101,9											

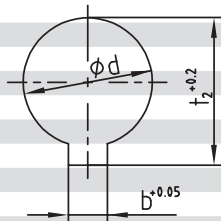

Basic programme taper 1:8					
Code	d ^{+0.05}	(d ₂)	b ^{JS9}	t ₂ ^{+0.1}	l _K
N/ 1	9,7	7,575	2,4 ^{+0.05}	10,85	17,0
N/ 1c	11,6	9,5375	3 ^{JS9}	12,90	16,5
N/ 1e	13,0	10,375	2,4 ^{+0.05}	13,80	21,0
N/ 1d	14,0	11,813	3 ^{JS9}	15,50	17,5
N/ 1b	14,3	11,8625	3,2 ^{+0.05}	5,65	19,5
N/ 2	17,287	14,287	3,2 ^{+0.05}	18,24	24,0
N/ 2a	17,287	14,287	4 ^{JS9}	18,94	24,0
N/ 2b	17,287	14,287	3 ^{JS9}	18,34	24,0
N/ 3	22,002	18,502	4 ^{JS9}	3,40	28,0
N/ 4	25,463	20,963	4,78 ^{+0.05}	27,83	36,0
N/ 4b	25,463	20,963	5 ^{JS9}	28,23	36,0
N/ 4a	27,0	22,9375	4,78 ^{+0.05}	28,80	32,5
N/ 4g	28,45	23,6375	6 ^{JS9}	29,32	38,5
N/ 5	33,176	27,676	6,38 ^{+0.05}	35,39	44,0
N/ 5a	33,176	27,676	7 ^{JS9}	35,39	44,0

For code N/6 and N/6a keywith parallel to the taper.

Basic programme taper 1:10					
Code	d ^{+0.05}	(d ₂)	b ^{JS9}	t ₂ ^{+0.1}	l _K
CX	19,95	16,75	5 ^{JS9}	22,08	32
DX	24,95	20,45	6 ^{JS9}	26,68	45
EX	29,75	24,75	8 ^{JS9}	31,88	50

Basic programme taper 1:5					
Code	d ^{+0.05}	(d ₂)	b ^{JS9}	t ₂ ^{+0.1}	l _K
A-10	9,85	7,55	2 ^{JS9}	1,0	11,5
B-17	16,85	13,15	3 ^{JS9}	1,8	18,5
C-20	19,85	15,55	4 ^{JS9}	2,2	21,5
Cs-22	21,95	17,65	3 ^{JS9}	1,8	21,5
D-25	24,85	19,55	5 ^{JS9}	2,9	26,5
E-30	29,85	23,55	6 ^{JS9}	2,6	31,5
F-35	34,85	27,55	6 ^{JS9}	2,6	36,5
G-40	39,85	32,85	6 ^{JS9}	2,6	35,0

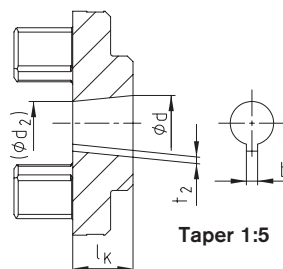

Taper 1:5

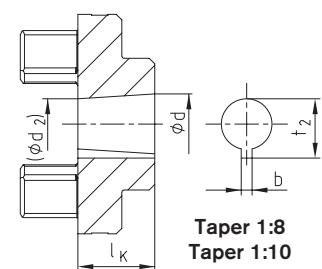

Taper 1:8
Taper 1:10

Shaft coupling design No. 001 - casted materials -

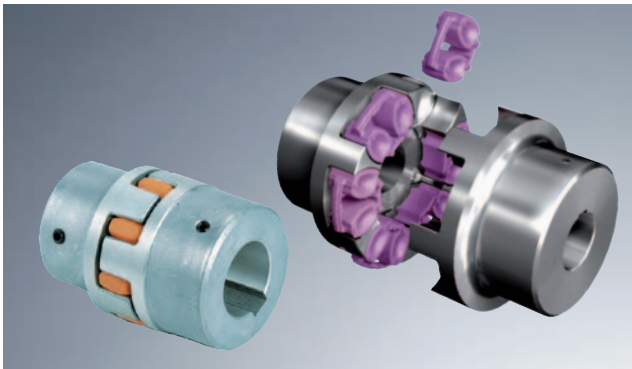

- Torsionally flexible, maintenance-free
- Damping vibrations
- Axial plug-in, fail-safe
- Machined alloy - good dynamic properties
- Compact design/low flywheel effect
- Finish bore acc. to ISO fit H7, feather keyway acc. to DIN 6885 sheet 1 - JS9.
- Stock programme/basic programme see pages 28 and 29
- Approved according to EC standard 94/9/EC (except for aluminium AL-D)
- Mounting instructions at www.ktr.com

Components

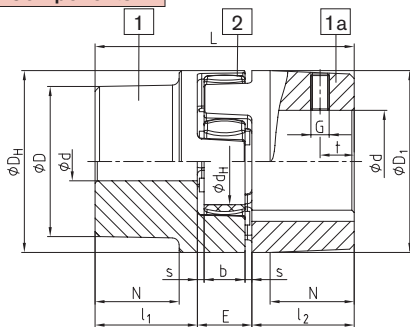

AL-D (thread opposite to the keyway)

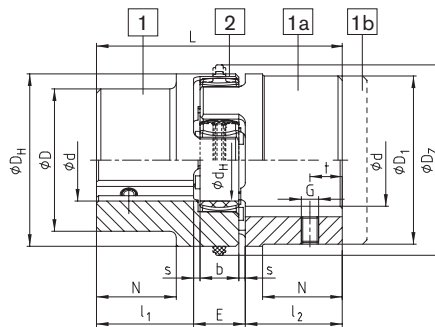

GJL / GJS (thread on the keyway)

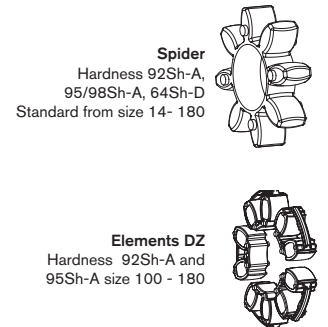

ROTEX® Aluminium diecast (AI-D)

Size	Component	Spider (part 2) ¹⁾ Rated torque [Nm]			Finish bore d (min-max)	Dimensions [mm]													
		92 Sh-A	98 Sh-A	64 Sh-D		General											Thread for setscrew		
						L	l ₁ ; l ₂	E	b	s	D _H	D _Z	d _H	D _i ; D ₁	N	G	t	T _A [Nm]	
14 ²⁾	1a	7,5	12,5	—	6-16	35	11	13	10	1,5	30	—	10	30	—	M4	5	1,5	
19	1	10	17	—	6-19	66	25	16	12	2	41	—	18	32	20	M5	10	2	
	41																		
24	1	35	60	—	9-24	78	30	18	14	2	56	—	27	40	24	M5	10	2	
	56																		
28	1	95	160	—	10-28	90	35	20	15	2,5	66	—	30	48	28	M8	15	10	
	66																		

ROTEX® Cast iron (GJL)

Size	Component	92 Sh-A	98 Sh-A	64 Sh-D	Rated torque [Nm]	Dimensions [mm]													
						L	l ₁ ; l ₂	E	b	s	D _H	D _Z	d _H	D _i ; D ₁	N	G	t	T _A [Nm]	
38	1	190	325	405	12-40	114	45	24	18	3	80	—	38	66	37	M8	15	10	
	38-48				78														
	1b				12-48									164					70
42	1	265	450	560	14-45	126	50	26	20	3	95	—	46	75	40	M8	20	10	
	42-55				94														
	1b				14-55									176					75
48	1	310	525	655	15-52	140	56	28	21	3,5	105	—	51	85	45	M8	20	10	
	48-62				104														
	1b				15-62									188					80
55	1	410	685	825	20-60	160	65	30	22	4	120	—	60	98	52	M10	20	17	
	55-74				118														
65	1	625	940	1175	22-70	185	75	35	26	4,5	135	—	68	115	61	M10	20	17	
75	1	1280	1920	2400	30-80	210	85	40	30	5	160	—	80	135	69	M10	25	17	
90	1	2400	3600	4500	40-97	245	100	45	34	5,5	200	218	100	160	81	M12	30	40	

ROTEX® Nodular iron (GJS)

Size	Component	92 Sh-A	98 Sh-A	64 Sh-D	Rated torque [Nm]	Dimensions [mm]													
						L	l ₁ ; l ₂	E	b	s	D _H	D _Z	d _H	D _i ; D ₁	N	G	t	T _A [Nm]	
100	1	3300	4950	6185	50-115	270	110	50	38	6	225	246	113	180	89	M12	30	40	
110	1	4800	7200	9000	60-125	295	120	55	42	6,5	255	276	127	200	96	M16	35	80	
125	1	6650	10000	12500	60-145	340	140	60	46	7	290	315	147	230	112	M16	40	80	
140	1	8550	12800	16000	60-160	375	155	65	50	7,5	320	345	165	255	124	M20	45	140	
160	1	12800	19200	24000	80-185	425	175	75	57	9	370	400	190	290	140	M20	50	140	
180	1	18650	28000	35000	85-200	475	195	85	64	10,5	420	450	220	325	156	M20	50	140	

■ = If no material is mentioned in the order, it is stipulated in the calculation/order.
¹⁾ Maximum torque of the coupling TK_{max}. = rated torque of the coupling TK_{Nenn}. x 2. see page 20/21 for selection.
²⁾ Material AL-H.

Ordering example:

ROTEX® 38	GJL	92 Sh-A	1a	Ø 45	1	Ø 25
Coupling size	Material	Spider hardness	Component	Finish bore	Component	Finish bore

Shaft coupling design No. 001 - material steel -

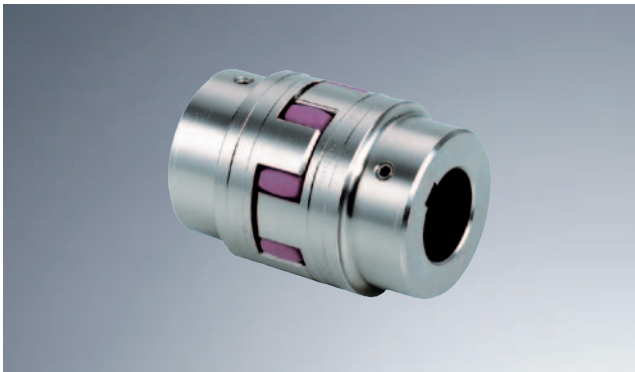

- Hubs from steel, specifically suitable for drive elements subject to high loads, e. g. steel mills, elevator drives, spline hubs, etc.)
- Torsionally flexible, maintenance-free, vibration-damping
- Axial plug-in, fail-safe
- Machined allover - good dynamic properties
- Compact design/low flywheel effect
- Finish bore acc. to ISO fit H7, feather keyway acc. to DIN 6885 sheet 1 - JS9.
- Stock programme/basic programme see pages 28 and 29
- Approved according to EC Standard 94/9/EC
- Mounting instructions at www.ktr.com

Components

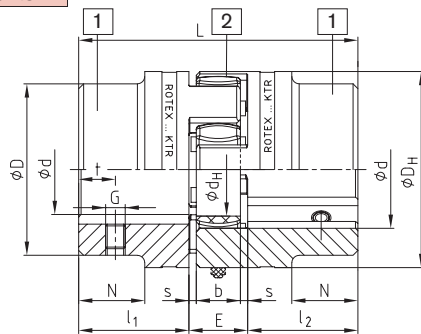

Steel (thread on the keyway)

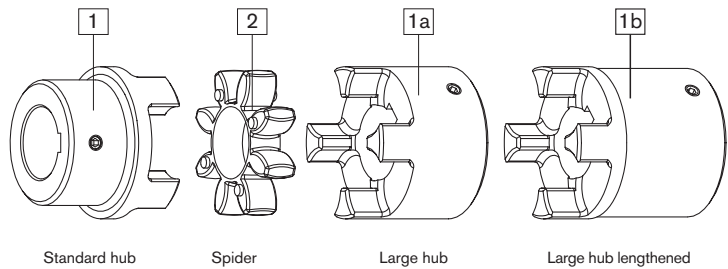

ROTEX® Steel (St)																	
Size	Component	Spider (part 2) ¹⁾ Rated torque [Nm]			Finish bore d (min-max)	Dimensions [mm]											
						General											Thread for setscrew
		92 Sh-A	98 Sh-A	64 Sh-D		L	l ₁ ; l ₂	E	b	s	D _H	d _H	D	N	G	t	T _A [Nm]
14	1a	7,5	12,5	16	0-16	35	11	13	10	1,5	30	10	30	-	M4	5	1,5
	50					18,5											
19	1a	10	17	21	0-25	66	25	16	12	2	40	18	40	-	M5	10	2
	90					37											
24	1a	35	60	75	0-35	78	30	18	14	2	55	27	55	-	M5	10	2
	118					50											
28	1a	95	160	200	0-40	90	35	20	15	2,5	65	30	65	-	M8	15	10
	140					60											
38	1	190	325	405	0-48	114	45	24	18	3	80	38	70	27	M8	15	10
	164					70	80						-				
42	1	265	450	560	0-55	126	50	26	20	3	95	46	85	28	M8	20	10
	176					75	95						-				
48	1	310	525	655	0-62	140	56	28	21	3,5	105	51	95	32	M8	20	10
	188					80	105						-				
55	1	410	685	825	0-74	160	65	30	22	4	120	60	110	37	M10	20	17
	210					90	120						-				
65	1	625	940	1175	0-80	185	75	35	26	4,5	135	68	115	47	M10	20	17
	235					100	135						-				
75	1	1280	1920	2400	0-95	210	85	40	30	5	160	80	135	53	M10	25	17
	260					110	160						-				
90	1	2400	3600	4500	0-110	245	100	45	34	5,5	200	100	160	62	M12	30	40
	295					125	200						-				

ROTEX® Sintered steel (GJS)																	
Size	Component	Spider (part 2) ¹⁾ Rated torque [Nm]		Finish bore d	Dimensions [mm]												
					General											Thread for setscrew	
		92 Sh-A	98 Sh-A		L	l ₁ ; l ₂	E	b	s	D _H	d _H	D	N	G	T _A [Nm]		
14	1a	7,5	12,5	unbored, 8, 10, 11, 12, 14, 15, 16	35	11	13	10	1,5	30	10	30	-	M4	5	1,5	
19	1a	10	17	unbored, 14, 16, 19, 20, 22, 24	66	25	16	12	2	40	18	40	-	M5	10	2	

■ = If no material is mentioned in the order, the material is stipulated with the calculation/order.
1) Maximum torque of the coupling TKmax. = rated torque of the coupling TK Nenn. x 2. Selection see page 20/21

ROTEX® 19 – 48 from stainless steel available from stock

- ROTEX® 19, 28 and 42 – hub material X10CrNiS 18-9 material number 1.4305 (V2A) DIN 17440
- ROTEX® 24, 38 and 48 – hub material X6CrNiMoTi17-12-2 material number 1.4571 (V4A) DIN 17440

Ordering example:	ROTEX® 38	St	92 Sh-A	1a – Ø 45		1 – Ø 25	
	Coupling size	Material	Spider hardness	Component	Finish bore	Component	Finish bore

Shaft coupling for taper clamping bush



- Shaft coupling for taper clamping bush
- Sliding fit facilitates the axial alignment of the coupling
- Short mounting length
- Easy assembly/disassembly of the coupling hubs
- Extra securing by positive locking, the clamping screws are each mounted by half in the coupling hub and in the taper clamping bush

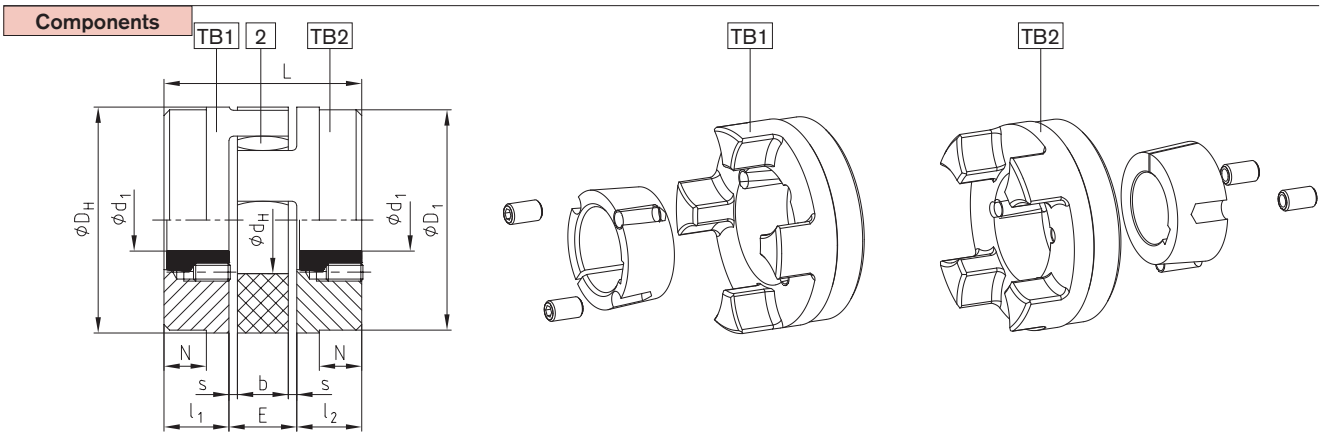

ROTEX® shaft coupling for taper clamping bush

Size	Taper clamping bush	Dimensions [mm]										Fastening screw for taper bush			
		$l_1:l_2$	E	s	b	L	N	D_H	D_1	d_H	Size [Inch] ¹⁾	Length [mm]	Number	T_A [Nm]	
24	1008	23	18	2,0	14	64	–	55	55	27	1/4	13	2	5,7	
28	1108	23	20	2,5	15	66	–	65	65	30	1/4	13	2	5,7	
38	1108	23	24	3,0	18	70	15	80	78	38	1/4	13	2	5,7	
42	1610	26	26	3,0	20	78	16	95	94	46	3/8	16	2	20	
48	1615	39	28	3,5	21	106	28	105	104	51	3/8	16	2	20	
55	2012	33	30	4,0	22	96	20	120	118	60	7/16	22	2	31	
65	2012	33	35	4,5	26	101	19	135	115	68	7/16	22	2	31	
75	2517	52	40	5,0	30	144	36	160	158	80	1/2	25	2	49	
	5/8										32	2	92		
90	3020	52	45	5,5	34	149	33	200	160	100	5/8	32	2	92	
100	3535	90	50	6	38	230	69	225	180	113	1/2	49	3	113	
125	4545	114	60	7,0	46	288	86	230	290	147	3/4	49	3	192	

Taper clamping bush

Size	Bore dimensions d_1 [mm] available; H7 fit – keyways to DIN 6885 sheet 1																		
1008	Ø10	Ø11	Ø12	Ø14	Ø16	Ø18	Ø19	Ø20	Ø22	Ø24	Ø25								
1108	Ø10	Ø11	Ø12	Ø14	Ø16	Ø18	Ø19	Ø20	Ø22	Ø24	Ø25	Ø28 ²⁾							
1610	Ø14	Ø16	Ø18	Ø19	Ø20	Ø22	Ø24	Ø25	Ø28	Ø30	Ø32	Ø35	Ø38	Ø40	Ø42*				
1615	Ø14	Ø16	Ø18	Ø19	Ø20	Ø22	Ø24	Ø25	Ø28	Ø30	Ø32	Ø35	Ø38	Ø40	Ø42*				
2012	Ø14	Ø16	Ø18	Ø19	Ø20	Ø22	Ø24	Ø25	Ø28	Ø30	Ø32	Ø35	Ø38	Ø40	Ø42	Ø45	Ø48	Ø50	
2517	Ø16	Ø18	Ø19	Ø20	Ø22	Ø24	Ø25	Ø28	Ø30	Ø32	Ø35	Ø38	Ø40	Ø42	Ø45	Ø48	Ø50	Ø55	Ø60
3020	Ø25	Ø28	Ø30	Ø35	Ø38	Ø40	Ø42	Ø45	Ø48	Ø50	Ø55	Ø60	Ø65	Ø70	Ø75				
3535	Ø35	Ø38	Ø40	Ø42	Ø45	Ø48	Ø50	Ø55	Ø60	Ø65	Ø70	Ø75	Ø80	Ø85	Ø90				
4545	Ø55	Ø60	Ø65	Ø70	Ø75	Ø80	Ø85	Ø90	Ø95	Ø100	Ø105	Ø110							

• Only available for design TB 2

¹⁾ 1. BSW thread

Coupling type TB 1/1; TB 2/2; TB 1/2 possible

Please order our separate dimension sheet (M 373054).

²⁾ Bores with feather keyway (flat design) acc. to DIN 6885 sheet 3

Ordering example:	ROTEX® 38	92 Sh-A	1108	TB1 – Ø 24		TB2 – Ø 22	
	Coupling size	Spider hardness	Taper clamping bush	Hub design	Finish bore	Hub design	Finish bore

Clamping ring hubs



- Torsionally flexible shaft coupling with integrated clamping system
- High running smoothness, application up to a peripheral speed of 40 m/s
- For high friction torques (consider the selection in case of explosion protection applications)
- Easy to assemble due to internal clamping screws
- Finish bore up to Ø 50 mm according to ISO fit H7, from Ø 55 mm according to ISO fit G77
- Ex Approved according to EC Standard 94/9/EC

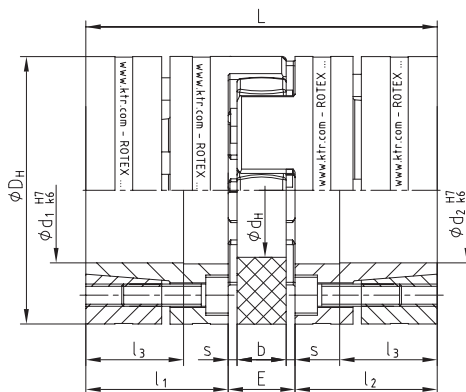

Pull-off thread
M₁ between
clamping
screws

Clamping ring hubs steel

Size	Torques [Nm] ¹⁾				Dimensions [mm]								Clamping screws			Weight per hub with max. bore [kg]	Mass moment of inertia per hub with max. bore [kgm ²]	
	92 Sh A		98 Sh A		D _H ²⁾	d _H	L	l ₁ ; l ₂	l ₃	E	b	s	M	Num-ber z	T _A [Nm]			M ₁
	T _{KN}	T _{Kmax}	T _{KN}	T _{Kmax}														
19	10,0	20	17	34	40	18	66	25	18	16	12	2,0	M4	6	4,1	M4	0,179	0,44 x 10 ⁻⁴
24	35,0	70	60	120	55	27	78	30	22	18	14	2,0	M5	4	8,5	M5	0,399	1,91 x 10 ⁻⁴
28	95,0	190	160	320	65	30	90	35	27	20	15	2,5	M5	8	8,5	M5	0,592	4,18 x 10 ⁻⁴
38	190,0	380	325	650	80	38	114	45	35	24	18	3,0	M6	8	14	M6	1,225	12,9 x 10 ⁻⁴
42	265	530	450	900	95	46	126	50	35	26	20	3,0	M8	4	35	M8	2,30	31,7 x 10 ⁻⁴
48	310	620	525	1050	105	51	140	56	41	28	21	3,5	M10	4	69	M10	3,08	52,0 x 10 ⁻⁴
55	375	750	685	1370	120	60	160	65	45	30	22	4,0	M10	4	69	M10	4,67	103,0 x 10 ⁻⁴
65	—	—	940 ³⁾	1880 ³⁾	135	68	185	75	55	35	26	4,5	M12	4	120	M12	6,70	191,0 x 10 ⁻⁴
75	—	—	1920 ³⁾	3840 ³⁾	160	80	210	85	63	40	30	5,0	M12	5	120	M12	9,90	396,8 x 10 ⁻⁴
90	—	—	3600 ³⁾	4500 ³⁾	200	104	245	100	75	45	34	5,5	M16	5	295	M16	17,70	1136 x 10 ⁻⁴

Bore d1/d2 and the corresponding transmittable friction torques T_R of clamping ring hub in [Nm] ¹⁾

Size	Ø10	Ø11	Ø14	Ø15	Ø16	Ø19	Ø20	Ø24	Ø25	Ø28	Ø30	Ø32	Ø35	Ø38	Ø40	Ø42	Ø45	Ø48	Ø50	Ø55	Ø60	Ø65	Ø70	Ø80	Ø90	Ø95	Ø100	Ø105	
19	27	32	69	84	57	94	110																						
24			70	87	56	97	114	116	133	192																			
28				108	131	207	148	253	285	315	382	330	433	503															
38							208	353	395	439	531	463	603	593	689	793	776												
42								358	398		483	416	547	536	625	571	704	851	865										
48											616	704	899	896	1030	962	1160	1379	1222	1543									
55													863	856	991	918	1119	1110	1247	1277	1672	1605	2008						
65															1446	1355	1637	1635	1827	1887	2429	2368	2930						
75																1710	2053	2059	2294	2384	3040	2983	3664	4293					
90																				3845	4249	4794	5858	5900	7036	8047	9247	9575	10845

¹⁾ Please note coupling selection on pages 140/141

²⁾ ØDH + 2 mm with high speeds for expansion of spider

³⁾ 95 Sh-A

The transmittable torques of the clamping connection consider the max. clearance with shaft fit k6/bore H7, from Ø55 G7/m6. With a higher clearance the torque is reduced. For the stiffness calculation of the shaft/hollow shaft please refer to KTR standard 45510 at our homepage www.ktr.com)

Ordering example:	ROTEX® GS 24	98 Sh-A	6.0 Steel	Ø24	6.0 Steel	Ø20
	Coupling size	Spider hardness	Hub design	Finish bore	Hub design	Finish bore

Clamping hubs

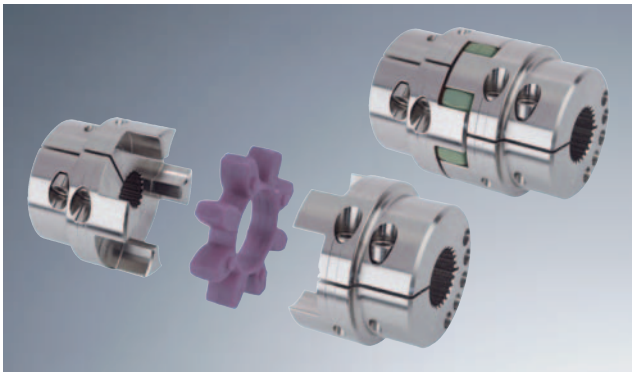

- Standard hub material steel
- Suitable in combination with spline bores according to DIN 5480, DIN 5482, SAE J498 (see page 28) and in addition DIN 9611, DIN 5463 (ISO 14), DIN 5481 and DIN 5472
- Balanced on the basis of 3D-CAD data
- Particularly suitable for applications with reversing operation
-  Approved according to EC standard 94/9/EC (only for hub designs 2.1 and 2.3, hub design 2.0 only according to category 3)
- Mounting instructions at www.ktr.com

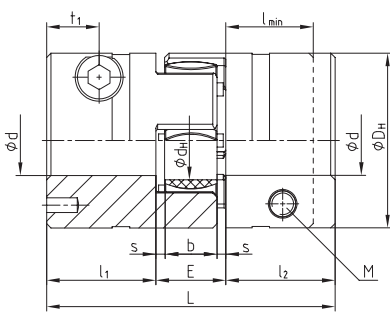

ROTEX® 19 - 28

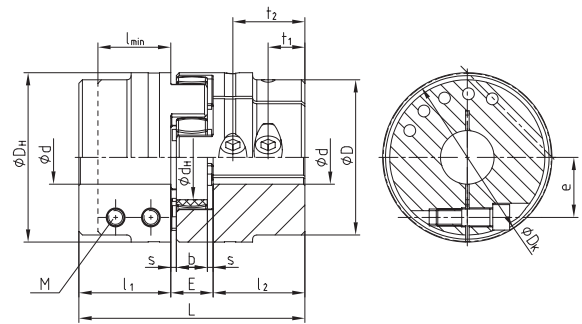

ROTEX® 38 - 90

ROTEX® as clamping hubs																	
Size	Dimensions [mm]														Screw DIN EN ISO 4762		
	max. d	L	l ₁ /l ₂	l _{min.}	E	b	s	D _H	D	d _H	D _K	t ₁	t ₂	e	M	T _A [Nm]	
19	20 ¹⁾	66	25	20	16	12	2,0	40	-	18	46,0	12	—	14,5	M6	14	
24	28	78	30	25	18	14	2,0	55	-	27	57,5	12	—	20,0	M6	14	
28	38	90	35	30	20	15	2,5	65	-	30	73,0	14 ²⁾	—	25,0	M8	35	
38	42	114	45	35	24	18	3,0	80	70	38	77,5	19	—	26,5	M8	35	
42	50	126	50	42	26	20	3,0	95	85	46	93,5	18 ²⁾	—	32,0	M10	69	
48	55	140	56	46	28	21	3,5	105	95	51	105,0	21 ²⁾	—	36,0	M12	120	
55	68	160	65	50	30	22	4,0	120	110	60	119,5	26	51 ²⁾	42,5 ³⁾	M12	120	
65	70	185	75	55	35	26	4,5	135	115	68	132,5	33	61 ²⁾	50,0 ³⁾	M12	120	
75	80	210	85	65	40	30	5,0	160	135	80	158,0	36	68 ²⁾	57,0 ³⁾	M16	295	
90	90	245	100	80	45	34	5,5	200	160	100	197,0	40	80 ²⁾	72,0 ³⁾	M20	580	

Bore area and the corresponding transmittable friction torques [Nm] of ROTEX® clamping hubs design 2.0																															
Size	Ø8	Ø10	Ø11	Ø14	Ø15	Ø16	Ø18	Ø19	Ø20	Ø22	Ø24	Ø25	Ø28	Ø30	Ø32	Ø35	Ø38	Ø40	Ø42	Ø45	Ø48	Ø50	Ø55	Ø60	Ø65	Ø70	Ø75	Ø80	Ø85	Ø90	
19	44	46	47	51	52	53	55	57	58																						
24		59	60	64	65	66	68	70	71	73	76	77	80																		
28				139	141	144	148	150	152	157	161	163	170	174	178	185	191														
38				163	165	170	172	174	178	183	185	192	196	200	207	213	217	222													
42									291	297	304	308	318	325	332	342	353	360	367	377	387	394									
48									466	476	486	491	506	516	526	542	557	567	577	592	607	618	643								
55															1185	1215	1245	1266	1286	1316	1347	1367	1417	1468	1519						
65																1316	1347	1367	1387	1417	1448	1468	1519	1569	1620	1671					
75																		2869	2926	2983	3022	3117	3213	3309	3404	3500	3595				
90																				5220	5310	5400	5460	5610	5760	5910	6060	6210	6360	6510	6660

¹⁾ With design 2.1 dmax. Ø17 mm

²⁾ With reduced hubs the dimension t₁ varies or the number of screws changes from 2-off to 1-off

³⁾ t₁ and t₂ have a different installation dimension e

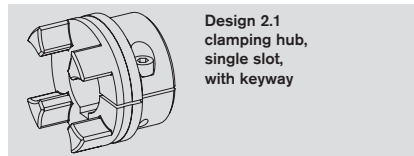
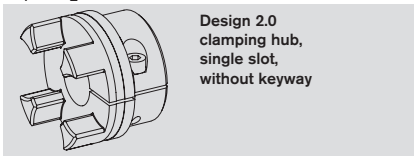

Ordering example:

ROTEX® 24	98 Sh-A	2.1	Ø 24	2.0	Ø20
Coupling size	Spider hardness	Hub design	Finish bore	Hub design	Finish bore

Flange programme design AFN and BFN



- Double flange design AFN and flange design BFN applicable to heavy machinery
- Radial assembly of driving or driven machine after disassembly of driving flanges
- For design AFN - spider to be replaced while coupling installed, without removal of driving or driven machine
- Power flow can be disconnected while coupling is installed
- Flange materials: component 4N (C-flange) made of steel, component 3Na (driving flange) made of GJS
- Finish bore acc. to ISO fit H7, feather keyway acc. to DIN 6885 sheet 1 - JS9.
- Approved according to EC standard 94/9/EC

Components

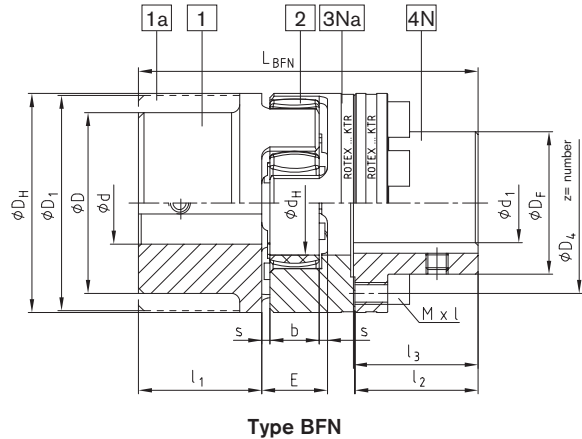
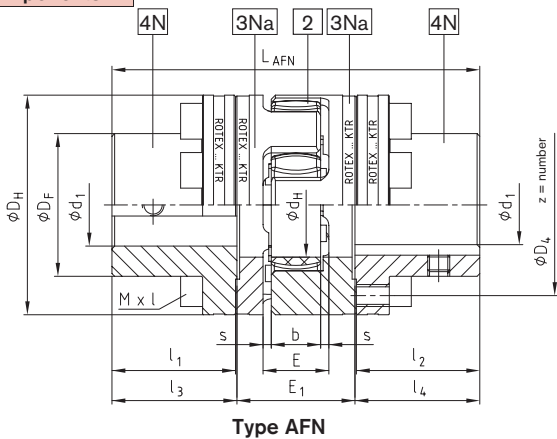

ROTEX® AFN (No. 002) and BFN (No. 004)

Size	Pilot bored $\phi_d, \phi_D;$ ϕ_{D_1}	Component 4N max. finish bore ϕ_{d_1}	Dimensions [mm]													Cyl. screws ³⁾ DIN EN ISO 4762 - 12.9			
			D_H	D_F	D_4	d_H	$l_1; l_2$	E	E_1	s	b	$l_3; l_4$	LAFN	LBFN	MxL	z	Pitch ²⁾	¹⁾ TA [Nm]	
24		24	55	36	45	27	30	18	33	2,0	14	30,5	94	86	M5x16	8		10	
28	see shaft coupling on pages 30 and 31 stock programme/basic programme see pages 28 and 29	28	65	42	54	30	35	20	39	2,5	15	35,5	110	100	M6x20	8	8x45°	17	
38		38	80	52	66	38	45	24	43	3,0	18	45,5	134	124	M8x22	8		41	
42		42	95	62	80	46	50	26	48	3,0	20	51,0	150	138	M8x25	12	16x22,5°	41	
48		48	105	70	90	51	56	28	50	3,5	21	57,0	164	152	M8x25	12		41	
55		55	120	80	102	60	65	30	60	4,0	22	66,0	192	176	M10x30	8	8x45°	83	
65		65	135	94	116	68	75	35	65	4,5	26	76,0	217	201	M10x30	12	16x22,5°	83	
75		75	160	108	136	80	85	40	75	5,0	30	86,5	248	229	M12x40	15		120	
90		100	200	142	172	100	100	45	82	5,5	34	101,5	285	265	M16x40	15		295	
100		110	225	158	195	113	110	50	97	6,0	38	111,5	320	295	M16x50	15		295	
110		125	255	178	218	127	120	55	103	6,5	42	122,0	347	321	M20x50	15	20x18°	580	
125		145	290	206	252	147	140	60	116	7,0	46	142,0	400	370	M20x60	15		580	
140		165	320	235	282	165	155	65	128	7,5	50	157,5	443	409	M20x60	15		580	
160		190	370	270	325	190	175	75	146	9,0	57	177,5	501	463	M24x70	15		1000	
180		220	420	315	375	220	195	85	159	10,5	64	198,0	555	515	M24x80	18	24x15°	1000	

¹⁾ Screw tightening torque T_A [Nm].
²⁾ Thread in driving flange between cams.
³⁾ Coupling is delivered not assembled.

Ordering example:

ROTEX® 24	AFN	92 Sh-A	4N	Ø 38	4N	Ø35
Coupling size	Type	Spider hardness	Component	Finish bore	Component	Finish bore

Drop-out center design coupling type A-H



- Assembly/disassembly by means of 4 screws only
- Replacement of spider with no need to shift the driving and driven side (motor and pump)
- Positive-locking and frictionally engaged hub combinations to be assembled radially (dimension E1 of type AFN = dimension E1 of type A-H)
- Finish bore according to ISO tolerance H7, feather key according to DIN 6885 sheet 1 - JS9
- Please order our separate dimension sheet (M425460)
- Approved according to EC standard 94/9/EC (type 7.8 shell clamping hub without feather key according to category 3)

Components

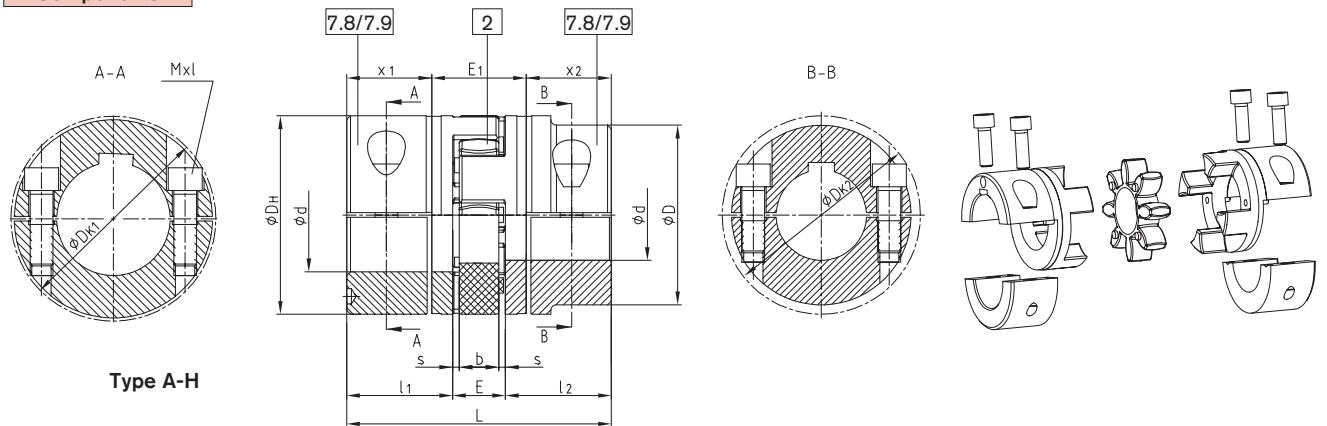

ROTEX® Type A-H															
Size	Max. finish bore Ød [mm]	Dimension [mm]											Cyl. screw DIN EN ISO 4762		
		L	l ₁ ; l ₂	E	b	s	D _H	D	DK ₁	DK ₂	x ₁ /x ₂	E ₁	Mxl	Tightening torque T _A [Nm]	
19	20	66	25	16	12	2,0	40	—	46	—	17,5	31	M6x16	14	
24	28	78	30	18	14	2,0	55	—	57,5	—	22,5	33	M6x20	14	
28	38	90	35	20	15	2,5	65	—	73	—	25,5	39	M8x25	35	
38	45	114	45	24	18	3,0	80	—	83,5	—	35,5	43	M8x30	35	
42	50	126	50	26	20	3,0	95	85	—	93,5	39	48	M10x30	69	
	—							97	—	M10x35					
48	55	140	56	28	21	3,5	105	95	—	105	45	50	M12x35	120	
	—							108,5	—	M12x40					
55	65	160	65	30	22	4,0	120	110	—	119,5	50	60	M12x40	120	
	—							122	—	M12x45					
65	70	185	75	35	26	4,5	135	115	—	123,5	60	65	M12x40	120	
	—							132,5	—	M12x45					
75	80	210	85	40	30	5,0	160	135	—	147,5	67,5	75	M16x50	295	
	—							158	—	M16x50					
90	90	245	100	45	34	5,5	200	160	—	176	81,5	82	M20x60	580	
	—							197	—	M20x60					
100 ¹⁾	110	270	110	50	38	6,0	225	180	—	185,5	84	102	M16x50	295	
110 ¹⁾	120	295	120	55	42	6,5	255	200	—	208	90	115	M20x60	580	
125 ¹⁾	140	340	140	60	46	7,0	290	230	—	242,5	105	130	M24x70	1000	

Please note:
With maximum bore the feather keys are offset to each other by approx. 5°!
Hub materials: up to size 90 steel
from size 100 GJS

7.8= Shell clamping hub without feather key
7.9= Shell clamping hub with feather key

¹⁾ From size 100: 4 clamping screws for each clamping hub.

Ordering example:	ROTEX® 38	A-H	98 Sh-A	7.8	Ø 38	7.8	Ø30
	Coupling size	Type	Spider hardness	Hub design	Finish bore	Hub design	Finish bore

Drop-out center design coupling type S-H with SPLIT-hubs

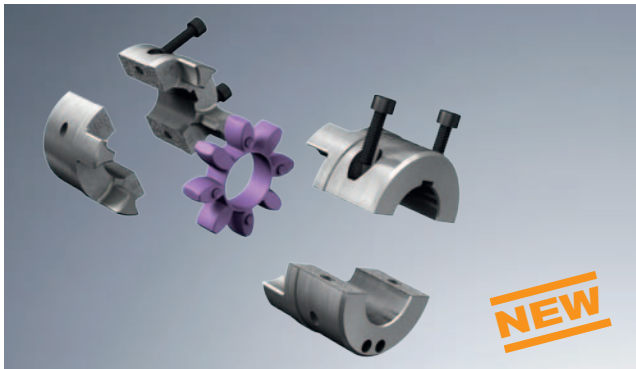

- Type S-H with split hubs
- Easy assembly/disassembly by means of 4-off screws
- Centering of both halves of the hubs through the fracture surface
- There is no need to displace the power packs for assembly
- Material cast iron
- Torsionally flexible and maintenance-free
- Specifically suitable for tight mounting spaces
- Finish bore according to ISO tolerance H7, feather key according to DIN 6885 sheet 1 - JS9
- Approved according to EC standard 94/9/EC (type 7.0 SPLIT-hub hub without feather key according to category 3)

Components

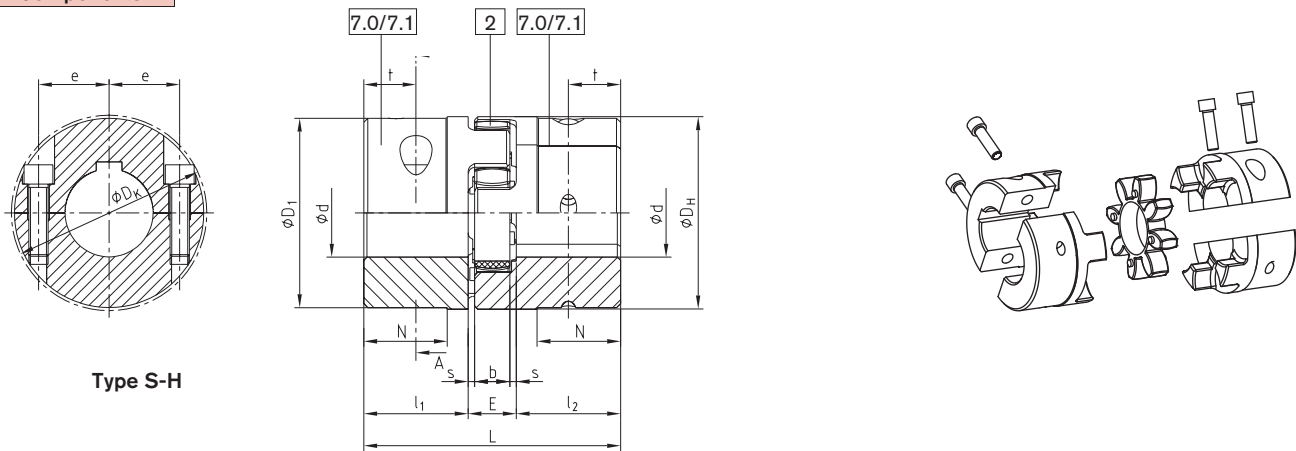

Type S-H

ROTEX® type S-H																
Size	Finish bore Ød [mm]		Dimensions [mm]											Cap screws to DIN EN ISO 4762		
	min.	max.	L	l ₁ ; l ₂	E	b	s	D _H	D ₁	D _K	N	e	t	Mxl	Tightening torque T _A [Nm]	
38	24	45	114	45	24	18	3	80	78	83,5	37	3	22,5	M8x30	35	
42	24	55	126	50	26	20	3	95	94	97	40	3	25	M10x30	69	
48	24	55	140	56	28	21	3,5	105	104	108,5	45	3,5	28	M12x35	120	
55	24	65	160	65	30	22	4	120	118	122	52	4	32,5	M12x40	120	
65 ¹⁾	40	70	185	75	35	26	4,5	135	-	132,5	-	4,5	37,5	M12x40	120	
75 ¹⁾	40	80	210	85	40	30	5	160	-	158	-	5	42,5	M16x50	295	
90 ¹⁾	40	90	245	100	45	34	5,5	200	-	197	-	5,5	50	M20x60	580	

7.0= split hub without feather keyway
7.1= split hub with feather keyway

¹⁾ sizes on request

Ordering example:	ROTEX® 38	S-H	98 Sh-A	7.1	Ø 38	7.1	Ø30
	Coupling size	Type	Spider hardness	Hub design	Finish bore	Hub design	Finish bore

Double cardanic type ZS-DKM-H



- Standard spacers up to 250 mm shaft distance dimension – from stock
- Assembly/disassembly by means of 4 screws only
- Compensates for high shaft displacements due to double-cardanic design
- Remains torsionally symmetric in case of shaft displacements
- Reduced vibration and noise
- Low restoring forces → Increase of the overall service life of all adjacent components (bearing, seals, etc.)
- Approved according to EC standard 94/9/EC (type 7.6 marked at stock, type 7.5 shell clamping hub without feather key according to category 3)

Components

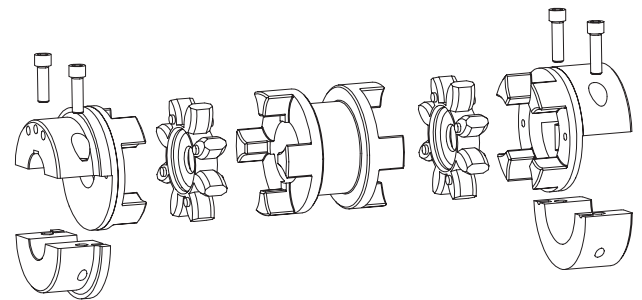
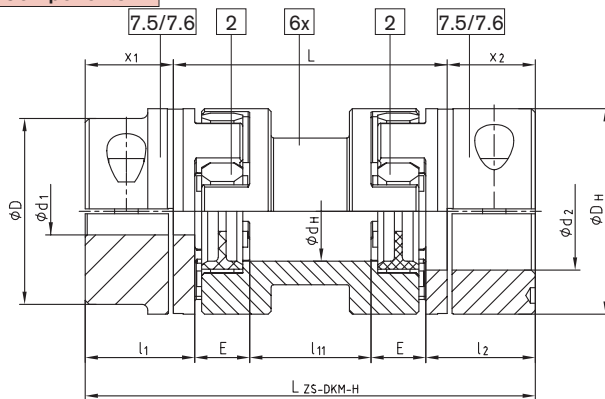

Type ZS-DKM-H

ROTEX® ZS-DKM-H																		
Size	Dis-mount-able bore length L [mm]	Max. finish bore Ød1/d2 [mm]	Spider (part 2) ¹⁾ T _{KN} [Nm]	Dimensions [mm]								Cyl. screw DIN EN ISO 4762 – 12.9		Max. displacements				Weight ²⁾ [kg]
				DH	dH	l ₁ ; l ₂	x ₁ ; x ₂	l ₁₁	E	LZS-DKM-H	M	T _A [Nm]	Axial [mm]	with n = 1500 rpm		with n = 3000 rpm		
														Radial [mm]	Angular [°]	Radial [mm]	Angular [°]	
24	100	28	35	55	27	30	22,5	49	18	145	M6	14	1,4	1,17		0,87		1,40
	89								185	1,87				1,40	1,60			
28	100	38	95	65	30	35	25,5	41	20	151	M8	35	1,5	1,06		0,80		1,90
	81								191	1,76				1,32	2,20			
38	100	45	190	80	38	45	35,5	33	24	171	M8	35	1,8	0,99		0,74		3,90
	73								211	1,69				1,27	4,10			
42	100	55	265	95	46	50	39,0	26	26	178	M10	69	2,0	0,91		0,68		5,10
	66								218	1,60				1,20	5,70			
48	100	60	310	105	51	56	45,0	22	28	190	M12	120	2,1	0,87		0,65		7,10
	62								230	1,57				1,18	7,90			
55	100	70	410	120	60	65	50,0	10		200	M12	120	2,2	0,70	1,0	0,52	0,75	9,50
	50								240	1,40				1,05	11,20			
65	140	80	625	135	68	75	60,0	90		280	M12	120	2,6	2,09		1,57		12,30
	110								300	2,44				1,83	12,80			
75	140	90	1280	160	80	85	67,5	40		260	M12	120	2,6	1,31		0,98		16,10
	80								300	2,00				1,50	16,80			
75	180	90	1280	160	80	85	67,5	25		275	M12	120	2,6	1,13		0,85		23,60
	65								315	1,83				1,37	26,00			
90	180	110	2400	200	100	100	81,5	85	40	335	M16	295	3,0	2,19		1,64		27,00
	135								385	3,05				2,29	29,50			
90	250	110	2400	200	100	100	81,5	53	45	343	M20	580	3,4	1,71		1,28		48,90
	123								413	2,93				2,19	52,60			

¹⁾ Maximum torque of coupling T_{Kmax.} = rated torque of coupling T_{KN} x 2

Size 24 to 90 spider type 95/98 Sh-A-GS
ZS-DKM-H: transmittable torque according to 92 Sh-A-GS

²⁾ Referring to max. bore

Finish bore according to ISO fit H7, feather keyway according to DIN 6885 sheet 1 - JS9.

7.5= Shell clamping hub without feather key for a double-cardanic connection

7.6= Shell clamping hub with feather key for a double-cardanic connection

ATTENTION: The standard line is only applicable for horizontal assembly. Vertical assembly on request.

Ordering example:	ROTEX® 38	ZS-DKM-H	140	98 Sh-A-GS	7.5	Ø 38	7.5	Ø30
	Coupling size	Type	Shaft distance dimension L	Spider hardness	Hub design	Finish bore	Hub design	Finish bore

Double-cardanic type DKM



- For big shaft displacements, 3-parted, double-cardanic
- Reduced vibration and noise
- The double-cardanic design allows for big shaft displacements with low restoring forces
- Increase of the overall service life of all adjacent components (bearings, seals etc.)
- Ex Approved according to EC standard 94/9/EC
- Mounting instructions at www.ktr.com
- Double-cardanic couplings without bearing require a protection for coupling

Components

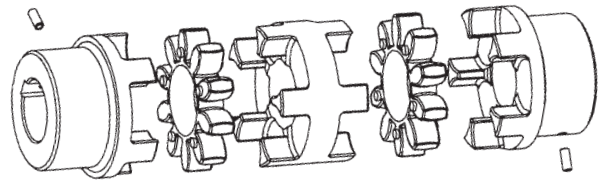
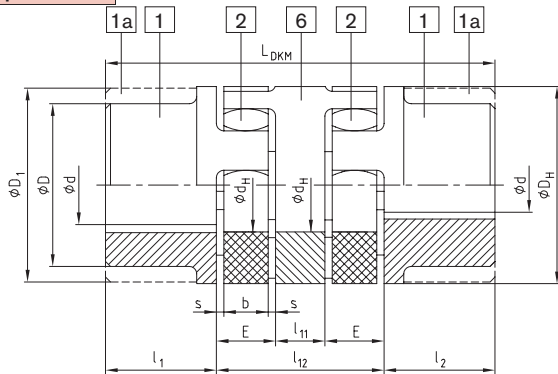

Type DKM

ROTEX® DKM (No. 018)																
Size	Ød, ØD, ØD ₁	Spider (part 2) Rated torque [Nm] ¹			Dimensions [mm]								Max. displacements with n = 1500 rpm			
		92 Sh-A	98 Sh-A	D _H	d _H	l ₁ ; l ₂	l ₁₁	l ₁₂	E	s	b	L _{DKM}	Radial [mm]	Angular [°]	Axial [mm]	
19		10	17	40	18	25	10	42	16	2,0	12	92	0,45	1,0	+1,2/-1,0	
24		35	60	55	27	30	16	52	18	2,0	14	112	0,59	1,0	+1,4/-1,0	
28		95	160	65	30	35	18	58	20	2,5	15	128	0,66	1,0	+1,5/-1,4	
38		190	325	80	38	45	20	68	24	3,0	18	158	0,77	1,0	+1,8/-1,4	
42		265	450	95	46	50	22	74	26	3,0	20	174	0,84	1,0	+2,0/-2,0	
48		310	525	105	51	56	24	80	28	3,5	21	192	0,91	1,0	+2,1/-2,0	
55		410	685	120	60	65	28	88	30	4,0	22	218	1,01	1,0	+2,2/-2,0	
65		625	940	135	68	75	32	102	35	4,5	26	252	1,17	1,0	+2,6/-2,0	
75		1280	1920	160	80	85	36	116	40	5,0	30	286	1,33	1,0	+3,0/-3,0	
90		2400	3600	200	100	100	40	130	45	5,5	34	330	1,48	1,0	+3,4/-3,0	

¹⁾ Selection on page 20/21
Finish bore according to ISO fit H7, feather keyway according to DIN 6885 sheet 1 - JS9.

Ordering example:

ROTEX® 38	DKM	GJL	98 Sh-A	1	Ø 38	1	Ø30
Coupling size	Type	Material	Spider hardness	Component	Finish bore	Component	Finish bore

Intermediate shaft programme design ZR

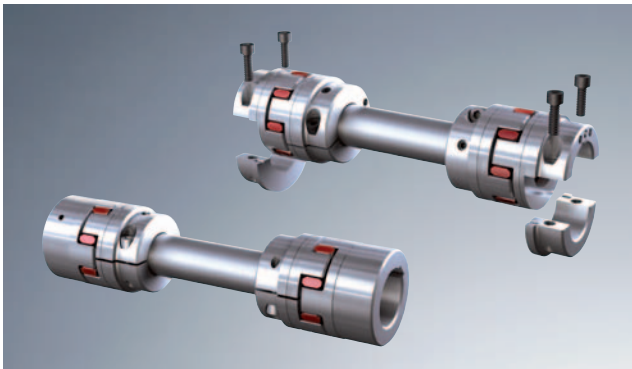

- To connect shaft ends with extended shaft separations
- Compensating for big shaft displacements due to the double-cardanic design
- Radial assembly possible without displacement of the driving or driven machine
- Particularly easy maintenance with the use of clamping hubs type DH (design 7.5 and 7.6)
- Flexible bearing in backlash-free ROTEX® GS spiders

Components

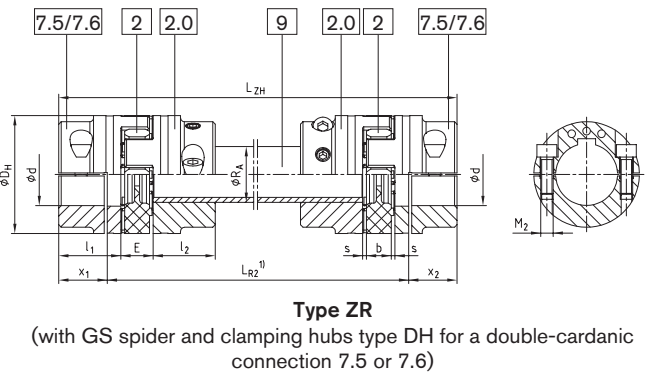
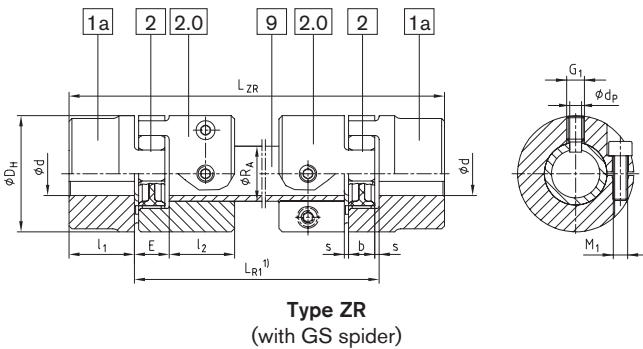

ROTEX® type ZR (No. 037)																					
Size	Finish bore ϕd		Dimensions [mm]						Intermediate pipe Torsional stiffness/m		Clamping screw Component 2.0		Clamping screw Component 7.5/7.6		$L_{ZR}; L_{ZH}$	min. L_{R1}	min. L_{R2}	Locking screw G_1	Cone bore d_p [mm]	Axial displacement [mm]	Angular displacement [degrees]
	Component 1a	Component 7.5/7.6	D_H	$l_1; l_2$	$x_1; x_2$	E	s	b	R_A	C^2 [Nm ² /rad]	M_1	T_A [Nm]	M_2	T_A [Nm]							
19	25	20	40	25	17,5	16	2,0	12	$\phi 20 \times 3$	954,9	M6	14	M6	10	110	97	M6	4,0	1,2	0,9	
24	35	28	55	30	22,5	18	2,0	14	$\phi 30 \times 4$	4522	M6	14	M6	14	128	111	M8	5,5	1,4	0,9	
28	40	38	65	35	25,5	20	2,5	15	$\phi 35 \times 4$	7611	M8	35	M8	35	145	129	M10	7,0	1,5	0,9	
38	48	45	80	45	35,5	24	3,0	18	$\phi 40 \times 4$	11870	M8	35	M8	25	180	157	M12	8,5	1,8	1,0	
42	55	55	95	50	39,0	26	3,0	20	$\phi 45 \times 4$	17487	M10	69	M10	49	198	174	M12	8,5	2,0	1,0	
48	62	60	105	56	45,0	28	3,5	21	$\phi 50 \times 4$	24648	M12	120	M12	86	217	190	M16	12	2,1	1,1	
55	74	70	120	65	50,0	30	4,0	22	$\phi 55 \times 4$	39662	M12	120	M12	120	242	220	M16	12	2,2	1,1	
65	80	80	135	75	60,0	35	4,5	26	$\phi 65 \times 5$	68329	M12	120	M12	120	281	250	M16	12	2,6	1,2	
75	95	90	160	85	67,5	40	4,0	30	$\phi 75 \times 5$	108000	M16	295	M16	295	318	285	M16	12	3,0	1,2	

¹⁾ Wir bitten, bei Anfragen und Bestellungen das Wellenabstandsmaß L_{R1}/L_{R2} anzugeben, sowie die max. Drehzahl zur Überprüfung der biegekritischen Drehzahl.
²⁾ Torsion spring stiffness when the intermediate pipe is 1m
 Finish bore acc. to ISO fit H7, feather key acc. to DIN 6885 sheet 1 - JS9
 Friction torques of clamping hubs have to be taken into account. Please order dimension sheet No. 5020/000/017-757537.



Diagramme for coupling selection:

Ordering example:

ROTEX® 38	ZR	1200	98 Sh-A-GS	7.5	$\phi 38$	7.5	$\phi 30$
Coupling size	Type	Shaft distance dim. L_{R1}/L_{R2}	Spider hardness	Hub design	Finish bore	Hub design	Finish bore

Flange programme designs CF, CFN, DF and DFN

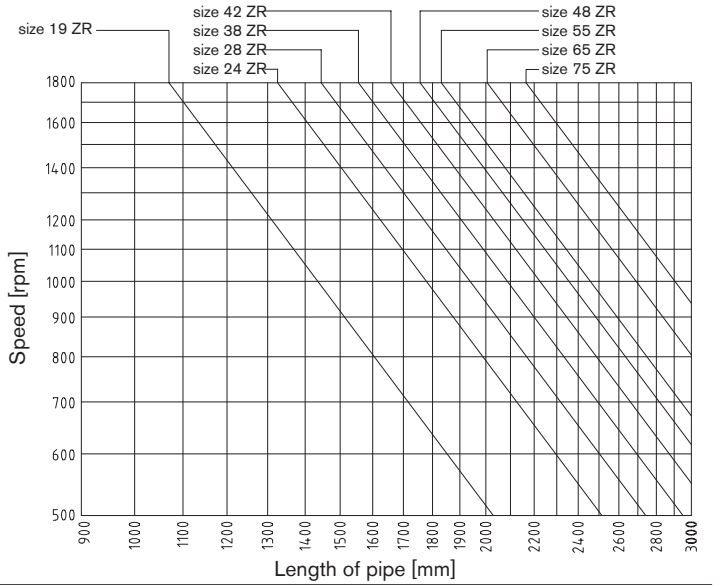
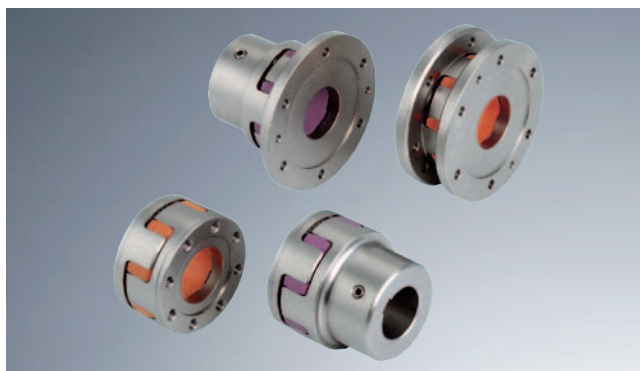

- Flange designs applicable to heavy machinery
- CF and CFN - connection flange to shaft
- DF and DFN - double flange design for the connection of driving and driven machine, radial assembly possible without removal of other components | quick replacement of spider
- CFN and DFN - particularly small outside diameters
- DF and DFN - particularly short mounting length
- DFN - for customer-specific mounting flanges
- Flange material part 3b: GJS
- Finish bore according to ISO fit H7, feather keyway according to DIN 6885 sheet 1 - JS9
- Approved according to EC standard 94/9/EC

Components

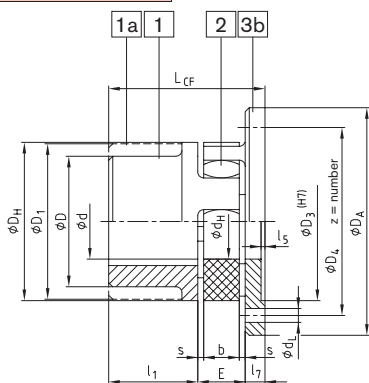

Type CF

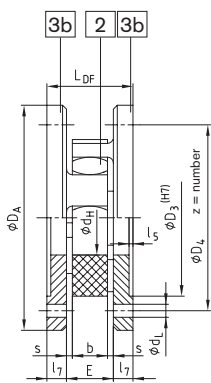

Type DF

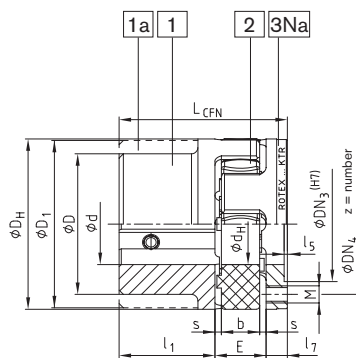

Type CFN

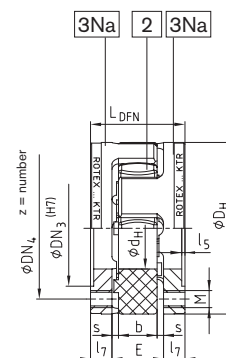

Type DFN

ROTEX® CF, CFN (No. 005) and DF, DFN (No. 006)

Size	d, ϕD_1 , ϕD_1	General dimension								Dimensions CF and DF						Dimensions CFN and DFN						
		D _H	d _H	l ₁	E	s	b	l ₅	l ₇	D _A	D ₃	D ₄	z	d _L	L _{CF}	L _{DF}	D _{N3}	D _{N4}	M	z	Pitch	L _{CFN}
24	55	27	30	18	2,0	14	1,5	8	80	55	65	5	4,5	56	34	36	45	M5	8		56	34
28	65	30	35	20	2,5	15	1,5	10	100	65	80	6	6,6	65	40	44	54	M6	8	8x45°	65	40
38	80	38	45	24	3,0	18	1,5	10	115	80	95	6	6,6	79	44	54	66	M8	8		79	44
42	95	46	50	26	3,0	20	2,0	12	140	95	115	6	9,0	88	50	65	80	M8	12	16x22,5°	88	50
48	105	51	56	28	3,5	21	2,0	12	150	105	125	8	9,0	96	52	75	90	M8	12		96	52
55	120	60	65	30	4,0	22	2,0	16	175	120	145	8	11,0	111	62	84	102	M10	8	8x45°	111	62
65	135	68	75	35	4,5	26	2,0	16	190	135	160	10	11,0	126	67	96	116	M10	12	16x22,5°	126	67
75	160	80	85	40	5,0	30	2,5	19	215	160	185	10	13,5	144	78	112	136	M12	15		144	78
90	200	100	100	45	5,5	34	3,0	20	260	200	225	12	13,5	165	85	145	172	M16	15		165	85
100	225	113	110	50	6,0	38	4,0	25	285	225	250	12	13,5	185	100	165	195	M16	15		185	100
110	255	127	120	55	6,5	42	4,0	26	330	255	290	12	18,0	201	107	180	218	M20	15	20x18°	201	107
125	290	147	140	60	7,0	46	5,0	30	370	290	325	16	18,0	230	120	215	252	M20	15		230	120
140	320	165	155	65	7,5	50	5,0	34	410	320	360	16	22,0	254	133	245	282	M20	15		254	133
160	370	190	175	75	9,0	57	5,0	38	460	370	410	16	22,0	288	151	280	325	M24	15		288	151
180	420	220	195	85	10,5	64	5,5	40	520	420	465	16	26,0	320	165	330	375	M24	18	24x15°	320	165

Other flange dimensions see page 35

Further types: ROTEX® CF-H

Flange drop-out center design coupling

Please order our separate dimension sheet (M412069)

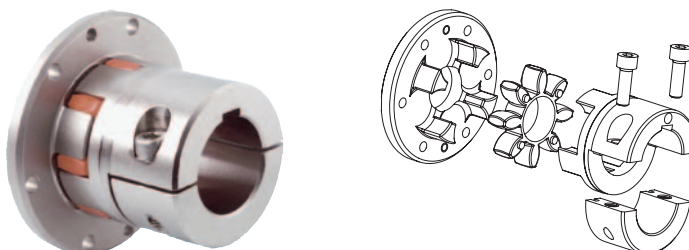

Ordering example:	ROTEX® 38	CF	92 Sh-A	1	GJL	Ø20
	Coupling size	Type	Spider hardness	Hub side Component	Material	Finish bore

Type BTAN with brake drum/type SBAN with brake disk



- Shaft coupling BTAN with brake drum to be mounted to external drum brakes with double shoes according to DIN 5431/15435
- Shaft coupling SBAN with disk for braking calipers
- Can be combined with different sizes of brake drums/disks (see table dimension „N/C“)
- The brake drum or brake disk has to be placed onto the shaft end with the biggest mass moment of inertia
- The maximum brake torque must not exceed the maximum torque of the coupling
- Designs BTAN and SBAN - modification for customer from the stock programme
- Mounting instructions at www.ktr.com

Components

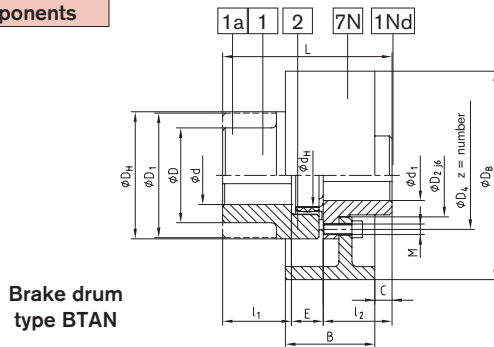

Brake drum type BTAN

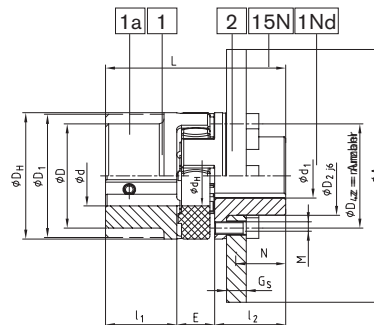

Brake disk type SBAN

ROTEX® type BTAN (No. 011) and SBAN (No. 013)

Size	Pilot bore ϕd ; ϕD ϕD_1	Finish bore max. d_1		Dimensions [mm]										
		GJS	Steel	D_H	D_2	D_4	d_H	z	Pitch ¹⁾	M	T_A [Nm]	l_1 ; l_2	E	L
38	—	—	34	80	50	66	38	8	8 x 45°	M8	41	45	24	114
42	—	—	42	95	60	80	46	12	16 x 22,5°	M8	41	50	26	126
48	—	—	48	105	68	90	51	12	16 x 22,5°	M8	41	56	28	140
55	—	—	55	120	78	102	60	8	8 x 45°	M10	83	65	30	160
65	—	—	65	135	92	116	68	12	16 x 22,5°	M10	83	75	35	185
75	—	—	75	160	106	136	80	15		M12	120	85	40	210
90	—	—	100	200	140	172	100	15		M16	295	100	45	245
100	100	—	225	156	195	113	15	20 x 18°		M16	295	110	50	270
110	110	—	255	176	218	127	15			M20	580	120	55	295
125	130	—	290	204	252	147	15			M20	580	140	60	340

Type BTAN											Type SBAN													
Brake drum	ROTEX® BTAN dimension „C“										Speed RPM [V] (30 m/s)	Brake disk	ROTEX® SBAN dimension „N“										Speed RPM [V] (30 m/s)	
	38	42	48	55	65	75	90	100	110	125			38	42	48	55	65	75	90	100	110	125		
160x60	14										3550	200x12,5	31,25								2800			
200x75	9	12	17	24							2800	250x12,5	31,25	34,25	39,25						2240			
250x95	1	4	9	16	25	33					2240	315x16		32,5	37,5	44,5	53,5	61,5			1800			
315x118		-5	0	7	16	24	36				1800	400x16			37,5	44,5	53,5	61,5	73,5	81,5	88,5	1400		
400x150		-18	-13	-6	3	11	23	31	38		1400	500x16				44,5	53,5	61,5	73,5	81,5	88,5	104,5	1120	
500x190					-12	-4	8	16	23	39	1120	630x20					51,5	59,5	71,5	79,5	86,5	102,5	900	
630x236						-22	-10	-2	5	21	900	710x20					51,5	59,5	71,5	79,5	86,5	102,5	800	
710x265								-13	-6	10	800	800x25								69	77	84	100	710
800x300										-4	710	900x25										84	100	630

¹⁾ Thread in the hub between the cams
Other sizes on request according to dimension sheet No.:
BTAN:M 380821
SBAN straight: M380822; cranked: M 370065
FNN hub: M 380823
Finish bore according to ISO fit H7, feather keyway according to DIN 6885 sheet 1 - JS9

Ordering example:

ROTEX® 38	BTAN	Ø200x75	98 Sh-A-GS	1Nd	Ø 38	1	Ø30
Coupling size	Type	ØBrake drum x width	Spider hardness	Component	Finish bore	Component	Finish bore

Type AFN-SB special with brake disk

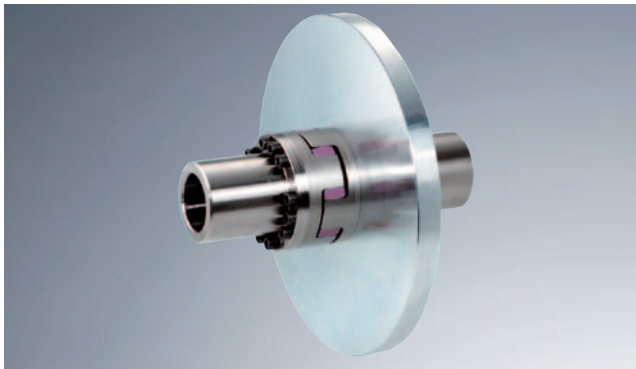

- Shaft coupling AFN-SB special with brake disk for brake calipers
- Brake disk and spider can be replaced while being assembled
- The brake disk has to be placed onto the shaft end with the biggest mass moment of inertia
- The maximum braking torque must not exceed the maximum torque of the coupling
- Finish bore according to ISO fit H7, feather keyway according to DIN 6885 sheet 1 - JS9
- Mounting instructions at www.ktr.com

Components

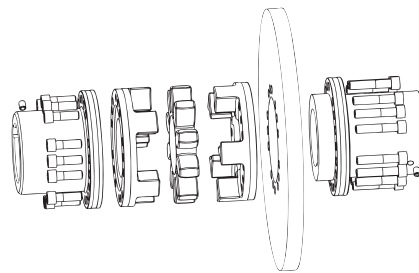
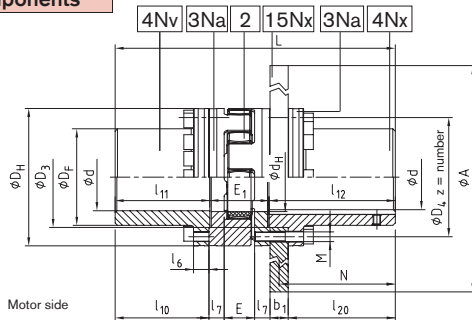

ROTEX® type AFN-SB special													
Size	Finish bore d		Dimensions [mm]										
	min.	max.	D_H	D_F	D_3 H7/h7	D_4	d_H	E	E_1	M	z	Pitch	T_A [Nm]
65	22	65	135	94	96	116	68	35	65	M10	12	16x22,5°	83
75	30	75	160	108	112	136	80	40	75	M12	15		120
90	40	100	200	142	145	172	100	45	82	M16	15		295
100	46	110	225	158	165	195	113	50	97	M16	15		295
110	60	125	255	178	180	218	127	55	103	M20	15	20x18°	580
125	60	145	290	206	215	252	147	60	116	M20	15		580
140	60	165	320	235	245	282	165	65	128	M20	15		580
160	80	190	370	270	280	325	190	75	146	M24	15		1000
180	85	220	420	315	330	375	220	85	159	M24	18	24x15°	1000

ROTEX® type AFN-SB special												
Size	Torque ¹⁾ with 95Sh-A		Max. speed [RPM]	Max. braking torque [Nm] ²⁾	Dimensions [mm]							
	T_{KN}	T_{Kmax}			l_7	l_{10}	l_{11}	l_{12}	l_{20}	N	L	
65	940	1880	3450	1880	16	112,5	113,5	166,0	135	150	344,5	
75	1920	3840	3250	3840	19	131,5	133,0	166,5	135	150	374,5	
90	3600	7200	3000	7200	20	164,0	165,5	206,5	175	190	454,0	
100	4950	9900	2800	9900	25	153,5	155,0	206,5	175	190	458,5	
110	7200	14400	2600	14400	26	201,5	203,5	212,0	180	195	518,5	
125	10000	20000	2250	20000	30	198,5	200,5	212,0	180	195	528,5	
140	12800	25600	1800	25600	34	244,5	247,0	252,5	220	235	627,5	
									210 ³⁾	230 ³⁾		
160	19200	38400	1500	38400	38	226,5	229,0	252,5	220	235	627,5	
									210 ³⁾	230 ³⁾		
180	28000	56000	1350	56000	40	195,0	198,0	252,5	220	235	609,5	

ROTEX® assignment of coupling/brake disk											
Size	Brake disk $\phi A \times b_1$										
	355x30	400x30	450x30	500x30	560x30	630x30	710x30	800x30	900x30	900x40	1000x40
65	x	x	x								
75		x	x	x							
90			x	x	x	x					
100				x	x	x					
110				x	x	x	x				
125						x	x	x			
140							x	x	x	x	x
160							x	x	x	x	x
180							x	x	x	x	x

¹⁾ Selection see page 20/21

²⁾ The max. braking torque must not exceed the maximum torque of the coupling.

³⁾ Dimensions for a brake disk width b_1 of 40 mm.

Ordering example:	ROTEX® 90	AFN-SB special	$\phi 450 \times 30$	98 Sh-A-GS	4Nv	$\phi 90$	4Nx	$\phi 90$
	Coupling size	Type	ϕ brake disk, x width	Spider hardness	Component	Finish bore	Component	Finish bore

Design SD (shiftable at standstill)



- Shiftable shaft coupling for all applications in general engineering
- Easy to engage and disengage driving or driven machines with standstill of machine
- Existing shifting hub to be combined with slip ring and shiftable linkage
- With pilot bored shifting hubs the requested shifting force must be set after final machining
- Other sizes on request according to M 370266
- Complete shifting device consisting of:
separated slip ring from red bronze, shift fork, shifting shaft, shifting lever, eye type bearing

Components

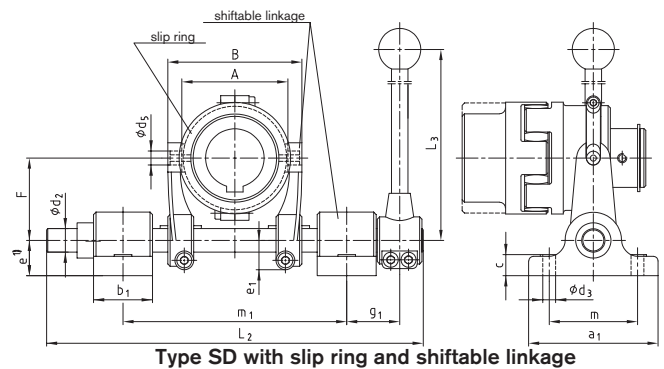
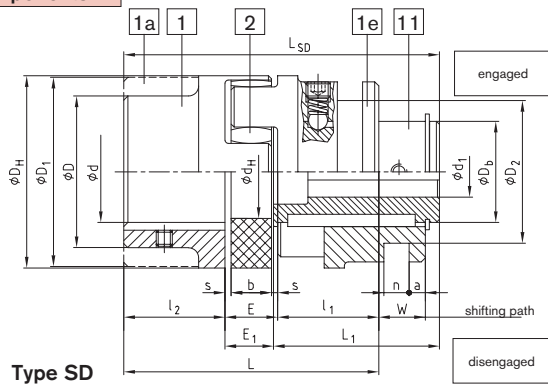

ROTEX® type SD (No. 015)																					
Size	Ød, ØD, ØD1	Finish bore d1		Dimensions [mm]														Shifting force set in [N]	Slip ring size	Shiftable linkage size	
		min.	max.	DH	D2±0,1	Db	dH	l1:l2	E	s	b	E1	L	L1	W	a	n±0,1				LSD
24	see shaft coupling on pages 30 and 31; stock programme/basic programme see pages 28 and 29	8	18	55	41	30	27	30	18	2,0	14	16,5	78	51,5	16,0	6	6,0	98	110	—	—
28		10	22	65	58	36	30	35	20	2,5	15	18,0	90	60,0	17,5	8	8,0	113	130	—	—
38		12	28	80	70,5	45	38	45	24	3,0	18	22,0	114	73,0	21,0	8	12,5	140	150	1.1	1
42		14	32	95	70,5	50	46	50	26	3,0	20	24,0	126	82,0	23,0	8	12,5	156	180	1.1	1
48		15	40	105	89,5	60	51	56	28	3,5	21	25,5	140	90,5	24,5	6	17,5	172	200	2.2	2
55		18	48	120	112,5	70	60	65	30	4,0	22	27,0	160	103,0	26,0	6	18,0	195	250	3.3	3
65		20	55	135	112,5	80	68	75	35	4,5	26	32,0	185	120,0	30,5	7	18,0	227	280	3.3	3
75		25	65	160	130,5	95	80	85	40	5,0	30	37,0	210	135,0	35,0	6	20,5	257	350	4.4	3
90		28	75	200	164,5	110	100	100	45	5,5	34	41,0	245	152,0	39,5	8	25,5	293	350	5.5	4
100		30	80	225	164,5	115	113	110	50	6,0	38	46,0	270	169,0	44,0	14	25,5	325	380	5.5	4
110		35	85	255	164,5	125	127	120	55	6,5	42	51,5	295	184,0	48,5	18,5	25,5	355	450	5.5	4
125	40	100	290	210,5	145	147	140	60	7,0	46	55,5	340	208,5	53,0	18,5	30,5	404	500	6.6	5	

Slip ring and shiftable linkage																																																																																																																																																															
Size	Shiftable linkage size	Dimensions [mm]																Max. speed for slip ring [RPM]																																																																																																																																													
		a1	b1	c	d2	d3	d5	e ¹⁾	e1	F	g1	L2	L3	m	m1 min.	m1 max.	A		B																																																																																																																																												
38	1	110	50	18	20	11	12	30	25	70	55	320	400	75	180	190	90	114	3280																																																																																																																																												
42	1																			140	25	17	40	32,5	120	70	490	600	100	280	310	140	180	210	1710																																																																																																																												
48	2																																			60	25	13,5	21	50	37,5	147,5	70	565	750	120	321	365	200	244	1360																																																																																																												
55	3																																																			160	30	25	25	46	190	80	630	1085	365	410	250	300	855																																																																																														
65	3																																																																	40	21	50	37,5	147,5	70	565	750	120	321	365	200	244	1360																																																																																
75	3																																																																															40	25	13,5	21	50	37,5	147,5	70	565	750	120	321	365	200	244	1360																																																																
90	4																																																																																															40	25	13,5	21	50	37,5	147,5	70	565	750	120	321	365	200	244	1360																																																
100	4																																																																																																															40	25	13,5	21	50	37,5	147,5	70	565	750	120	321	365	200	244	1360																																
110	4																																																																																																																															40	25	13,5	21	50	37,5	147,5	70	565	750	120	321	365	200	244	1360																
125	5																																																																																																																																															40	25	13,5	21	50	37,5	147,5	70	565	750	120	321	365	200	244	1360

¹⁾ In case of a through base plate the dimension „e“ of the shiftable linkage size 5 has to be increased by at least 10 mm. Finish bore according to ISO fit H7, feather keyway according to DIN 6885 sheet 1 - JS9

Ordering example:	ROTEX® 38	SD	with 1,1 and 1	98 Sh-A-GS	1	Ø38	11	Ø90
	Coupling size	Type	with slip ring 1.1 and shifting linkage 1	Spider hardness	Component	Finish bore	Component	Finish bore

Design FNN and FNN with fan

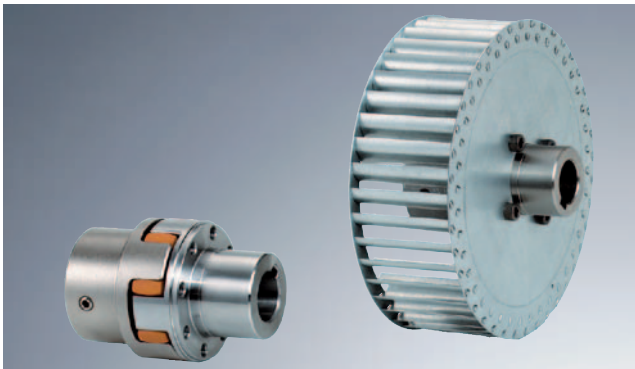

- Damping vibrations and reducing noise
- Perfect compensation for misalignment due to crowned teeth
- Coupling as plug-in design
- Easy inspection of wear by sight control
- Coupling to be equipped with any fan
- Finish bore according to ISO fit H7, feather keyway according to DIN 6885 sheet 1 - JS9

Components

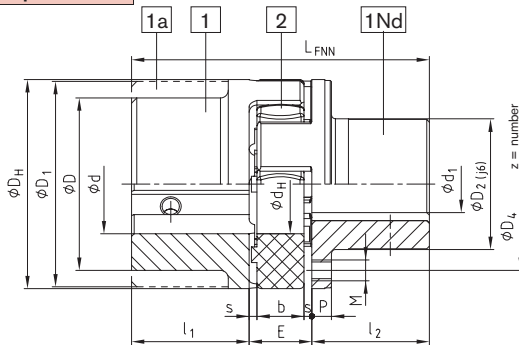

Type FNN

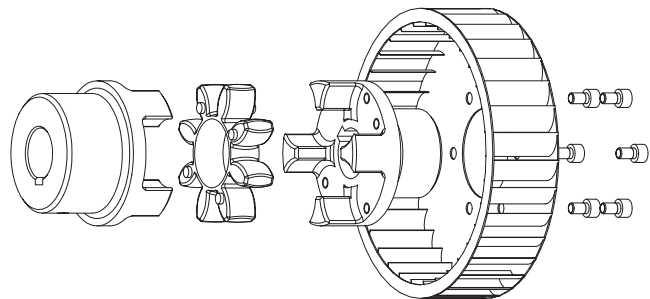

Type FNN with fan (type 1)

ROTEX® type FNN (No. 021)

Size	$\phi d, \phi D, \phi D_1$	Max. finish bore ϕd_1	Dimensions [mm]												
			D_H	D_2	D_4	d_H	E	s	b	l_1, l_2	P	M	z	Pitch	L_{FNN}
28		24	65	40	54	30	20	2,5	15	35	6,5	M6	8		90
38		34	80	50	66	38	24	3,0	18	45	7,5	M8	8	8x45°	114
42		42	95	60	80	46	26	3,0	20	50	9,5	M8	12	16x22,5°	126
48		48	105	68	90	51	28	3,5	21	56	10,5	M8	12	16x22,5°	140
55		55	120	78	102	60	30	4,0	22	65	12,5	M10	8	8x45°	160
65		65	135	92	116	68	35	4,5	26	75	13,5	M10	12	16x22,5°	185
75		75	160	106	136	80	40	5,0	30	85	15,5	M12	15	20x18°	210
90		100	200	140	172	100	45	5,5	34	100	18,5	M16	15	20x18°	245

Other sizes on request

Type 1: Fan screwed on

The ROTEX® coupling can be supplied with the fan screwed on. Specific connection dimensions of customers such as pitch circle of threads, size of threads and number or centering of fans should be mentioned in your inquiry.

Type 2: Fan injection-moulded

Low prices due to production volumes with higher quantities.

Type 3: Fan pressed or glued on

Special surface forming (knurling according to DIN 82) allows the fan to be pressed or glued onto the hub collar.

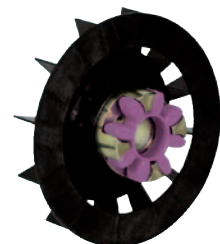

Ordering example:

ROTEX® 38	FNN	92 Sh-A	1	Ø 38	1Nd	Ø30
Coupling size	Type	Spider hardness	Component	Finish bore	Component	Finish bore

Further types with clamping sets

Components

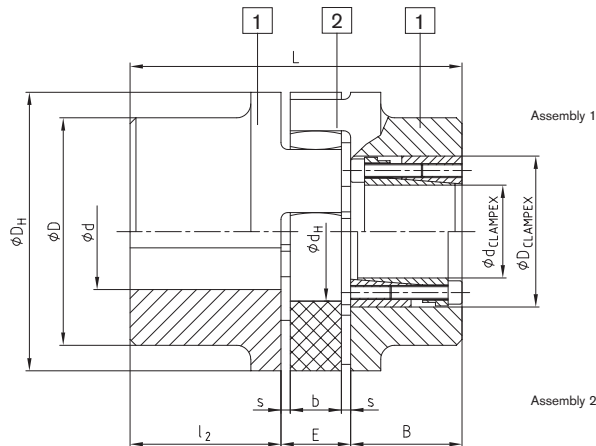

ROTEX® type No. 001 with clamping set CLAMPEX® KTR 200														
Size	$\phi d, \phi D, \phi D_1$	Hub material	CLAMPEX® KTR 200			B	Dimensions [mm]							
			Max. size of KTR clamping set dxD	Transmittable torque and axial force			l_2	E	s	b	D_H	D	d_H	L
				T [Nm]	F _{AX} [kN]									
42	see shaft coupling on pages 30 and 31 basic programme see pages 28 and 29	Steel part 1	30x55	769	51	48	50	26	3,0	20	95	—	46	length = $l_2 + B$ (clamping set)
48			35x60	1197	68	48	56	28	3,5	21	105	—	51	
55			45x75	2132	95	59	65	30	4,0	22	120	—	60	
65			45x75	2132	95	59	75	35	4,5	26	135	115	68	
75			50x80	3159	126	59	85	40	5,0	30	160	135	80	
90			65x95	4107	126	59	100	45	5,5	34	200	160	100	
100			65x95	4107	126	59	110	50	6,0	38	225	180	113	
110			70x110	7023	201	70	120	55	6,5	42	255	200	127	
125			80x120	8026	201	70	140	60	7,0	46	290	230	147	
140		95x135	11373	239	70	155	65	7,5	50	320	255	165		
160		110x155	16068	292	80	175	75	9,0	57	370	290	190		
180		120x165	21910	365	80	195	85	10,5	64	420	325	220		

ROTEX® type No. 001 with clamping set CLAMPEX® KTR 200																	
KTR 200 size	Length	Transmittable torque and axial force		Clamping screws DIN EN ISO 4762 – 12.9		KTR 200 Size	Length	Transmittable torque and axial force		Clamping screw DIN EN ISO 4762 – 12.9		KTR 200 Size	Length	Transmittable torque and axial force		Clamping screws DIN EN ISO 4762 – 12.9	
		T [Nm]	F _{ax} [kN]	zxM	T _A [Nm]			dxD	B	T [Nm]	F _{ax} [kN]			zxM	T _A [Nm]	dxD	B
20x47	48	513	51	6xM6	17	38x65	48	1299	68	8xM6	17	65x95	59	4107	126	8xM8	41
22x47	48	564	51	6xM6	17	40x65	48	1368	68	8xM6	17	70x110	70	7023	201	8xM10	83
24x50	48	616	51	6xM6	17	42x75	59	1990	95	6xM8	41	75x115	70	7524	201	8xM10	83
25x50	48	641	51	6xM6	17	45x75	59	2132	95	6xM8	41	80x120	70	8026	201	8xM10	83
28x50	48	718	51	6xM6	17	48x80	59	3033	126	8xM8	41	85x125	70	10659	251	10xM10	83
30x55	48	769	51	6xM6	17	50x80	59	3159	126	8xM8	41	90x130	70	11286	251	10xM10	83
32x60	48	1094	68	8xM6	17	55x85	59	3475	126	8xM8	41	95x135	66	11373	239	10xM10	83
35x60	48	1197	68	8xM6	17	60x90	59	3791	126	8xM8	41	for further details please see CLAMPEX® catalogue					

Design 4.2 with CLAMPEX® clamping set KTR 250

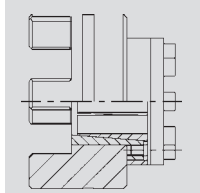

Frictionally engaged, backlash-free shaft-hub-connection for transmission of average torques.

Design 4.3 with CLAMPEX® clamping set KTR 400

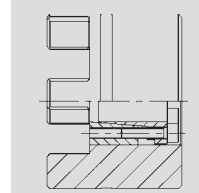

Frictionally engaged, backlash-free shaft-hub-connection for transmission of bigger torques. Maximum size of clamping set depends on the hub collar diameter. Clamping set screw fitting possible both internally and externally. For details of calculation please see CLAMPEX® catalogue.

Further designs with torque limiter

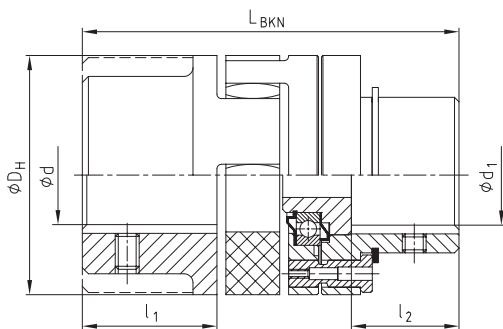

ROTEX® BKN - shear pin coupling, type BKN No. 009							
Size	Max. finish bore d	Max. finish bore d ₁	l ₁	l ₂	L _{BKN}	D _H	Min. fracture torque [Nm]
28	see shaft coupling on pages 30 and 31, basic programme see pages 28 and 29	28	35	25	101	65	100
38		38	45	35	125	80	190
42		42	50	40	139	95	250
48		48	56	46	153	105	300
55		55	65	55	177	120	400
65		65	75	65	202	135	500
75		75	85	70	230	160	600
90		100	100	85	266	200	700

Modification for customer from the stock programme.
Please mention the fracture torques with your order!
For further details please see dimension sheet No. 5020/000/009-7603

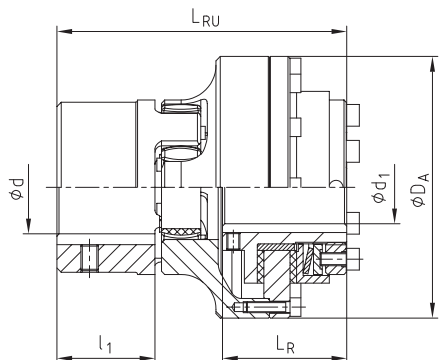

ROTEX® - RUFLEX® - coupling with torque limiter, type No. 070								
ROTEX® size	RUFLEX® size	Ratchet torques [Nm]	d	d ₁ max.	D _A	l ₁	L _R	L _{RU}
14	00	0,5 — 5	see shaft coupling on pages 30 and 31, basic programme see pages 28 and 29	10	44	11	31	59
19	0	2 — 20		20 ¹⁾	63	25	33	78
24	01	5 — 70		22	80	30	45	98
28	1	20 — 200		25	98	35	52	113
38	2	25 — 400		35	120	45	57	133
48	3	50 — 800		45	162	56	68	166
75	4	90 — 1600		55	185	85	78	205

¹⁾ Finish bore exceeding ø 19, keyway according to 6885 sheet 3

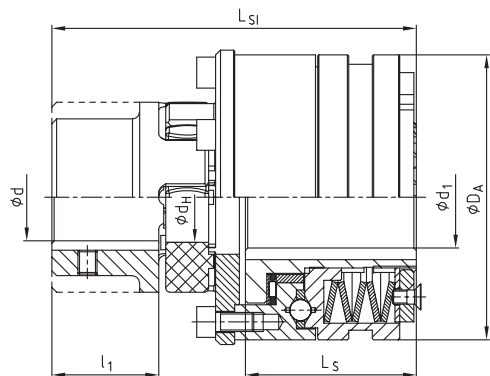

ROTEX® - KTR-SI - coupling with torque limiter, type No. 070									
ROTEX® size	KTR-SI type	KTR-SI size	Ratchet torques [Nm]	d	max. d ₁	D _A	l ₁	L _S	L _{SI}
28	DK	2	12-200	see shaft coupling on pages 30 and 31, basic programme see pages 28 and 29	35	100	35	56	124
	SR/SGR	0	5-40		20	55		34,5	102
38	DK	3	25-450		45	120	45	73	155
	SR/SGR	1	12-100		25	82		48	129,5
48	DK	4	50-1000		55	146	56	93,5	194
	SR/SGR	2	25-200		35	100		56	155
55	DK	5	85-2000		65	176	65	107	222,5
	SR/SGR	3	50-450		45	120		73	186
75	DK	—	—	—	—	85	—	—	
	SR/SGR	4	100-2000	55	146		93,5	241,5	
90	DK	—	—	—	—	100	—	—	
	SR/SGR	5	170-3400	65	176		107	275,5	

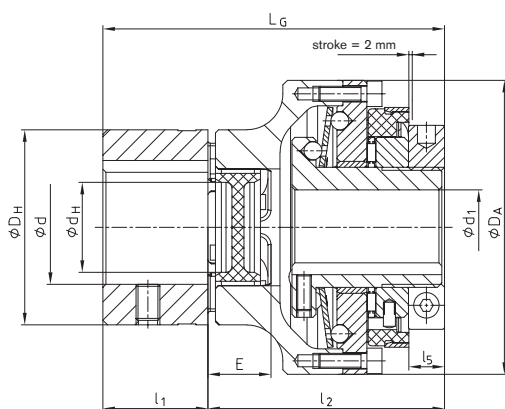

SYNTAX® - backlash-free, torsionally rigid overload coupling with ROTEX® GS																
ROTEX® size	SYNTAX® size	SYNTAX® torque range disk spring [Nm]				Max. bore		D _A	D _H	d _H	E	L	L _G	l ₁	l ₂	l ₅
		DK ₁	DK ₂	SK ₁	SK ₂	d	d ₁									
24	20	6-20	15-30	10-20	20-65	35	20	80	55	27	18	45	100	30	70	10
28	25	20-60	45-90	25-65	40-100	40	25	98	65	30	20	50	113	35	78	11
38	35	25-80	75-150	30-100	70-180	48	35	120	80	38	24	60	136	45	91	13
48	50	60-180	175-300	80-280	160-400	55	50	162	105	51	28	70	167	56	111	14

Weights and mass moments of inertia

Components

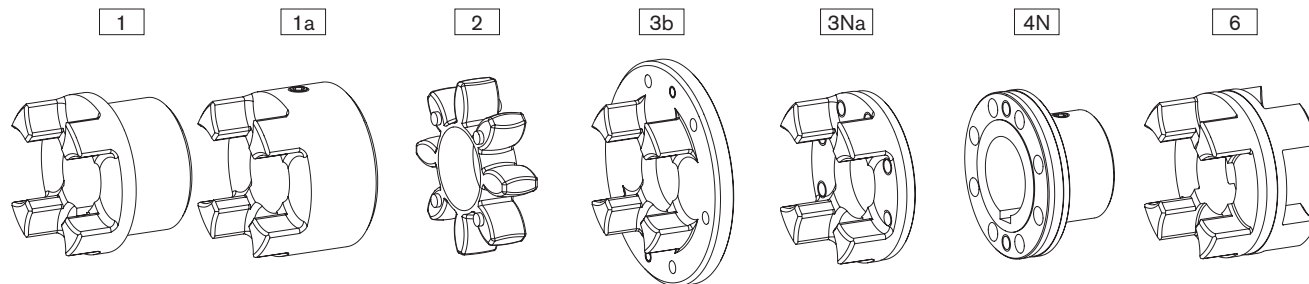

ROTEX® components														
Size	Standard hub				Large hub			Spider	Driving flange			C-flange	DKM spacer	
	Part 1				Part 1a			Part 2	Part 3b	Part 3Na		Part 4N	Part 6	
	Alu [kg] [kgm²]	GJL [kg] [kgm²]	GJS [kg] [kgm²]	St [kg] [kgm²]	Alu [kg] [kgm²]	GJL [kg] [kgm²]	St [kg] [kgm²]	Polyurethane (Vulkollan) [kg] [kgm²]	GJS [kg] [kgm²]	St [kg] [kgm²]	GJS [kg] [kgm²]	St [kg] [kgm²]	Alu [kg] [kgm²]	
14	—	—	—	—	0,020	—	—	0,0044	—	—	—	—	—	
	—	—	—	—	0,000003	—	—	0,0000005	—	—	—	—	—	
19	0,064	—	—	—	0,074	—	0,25	0,0056	—	—	—	—	—	
	0,00001	—	—	—	0,00002	—	0,00006	0,000001	—	—	—	—	—	
24	0,123	—	—	—	0,174	—	0,55	0,014	0,028	0,145	—	0,30	0,14	
	0,00004	—	—	—	0,00008	—	0,00023	0,000006	0,00023	0,00007	—	0,00009	0,00006	
28	0,200	—	—	—	0,264	—	0,89	0,024	0,54	0,232	—	0,49	0,22	
	0,00010	—	—	—	0,00019	—	0,00053	0,000010	0,0007	0,00017	—	0,0002	0,00013	
38	0,44	1,16	—	1,6	0,470	1,32	1,74	0,042	0,73	—	0,313	0,87	0,35	
	0,00033	0,00086	—	0,00151	0,00046	0,00135	0,00155	0,00003	0,001	—	0,00038	0,0005	0,00035	
42	0,69	1,75	—	2,44	0,772	2,05	2,74	0,065	1,26	—	0,608	1,4	0,47	
	0,00067	0,00178	—	0,00281	0,00111	0,00291	0,00343	0,00007	0,0032	—	0,00089	0,0011	0,00068	
48	0,80	2,44	—	3,34	1,01	2,78	3,72	0,086	1,45	—	0,755	1,92	0,62	
	0,011	0,00308	—	0,00473	0,00174	0,00484	0,00570	0,00013	0,0043	—	0,001358	0,0018	0,0011	
55	—	3,68	—	5,05	—	4,08	5,57	0,11	2,58	—	1,243	2,93	0,90	
	—	0,00615	—	0,00948	—	0,00926	0,01193	0,00023	0,0105	—	0,002920	0,0037	0,0021	
65	—	5,67	—	6,79	—	6,04	8,22	0,17	3,10	—	1,635	4,36	1,31	
	—	0,01240	—	0,01516	—	0,01789	0,02079	0,00042	0,0149	—	0,004891	0,0069	0,0039	
75	—	8,72	—	10,5	—	9,53	14,3	0,32	4,46	—	2,511	6,80	1,97	
	—	0,02644	—	0,03269	—	0,03946	0,05069	0,00116	0,0281	—	0,01050	0,0151	0,0082	
90	—	14,8	—	18,7	—	18,2	24,0	0,57	6,94	—	4,151	12,84	3,45	
	—	0,06730	—	0,08742	—	0,15086	0,13151	0,00323	0,0651	—	0,02723	0,0448	0,0224	
100	—	—	19,7	—	—	—	—	0,81	10,2	—	6,350	16,16	—	
	—	—	0,11694	—	—	—	—	0,00588	0,1165	—	0,05273	0,0798	—	
110	—	—	27,4	—	—	—	—	1,19	—	—	8,578	21,35	—	
	—	—	0,20465	—	—	—	—	0,01097	—	—	0,09121	0,2824	—	
125	—	—	42,3	—	—	—	—	1,63	—	—	12,598	34,33	—	
	—	—	0,40727	—	—	—	—	0,01972	—	—	0,17469	0,3229	—	
140	—	—	58,1	—	—	—	—	2,11	—	—	17,271	48,69	—	
	—	—	0,67739	—	—	—	—	0,03129	—	—	0,29247	0,4917	—	
160	—	—	84,2	—	—	—	—	3,21	—	—	26,305	71,08	—	
	—	—	1,31729	—	—	—	—	0,06323	—	—	0,59436	0,9693	—	
180	—	—	118,5	—	—	—	—	5,25	—	—	33,076	109,43	—	
	—	—	2,30835	—	—	—	—	0,13789	—	—	0,97394	1,9650	—	

Weight and mass moment of inertia each refer to the average finish bore without keyway.

Weights and mass moments of inertia

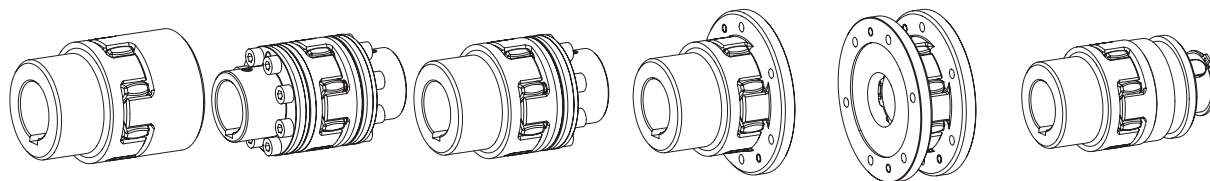

ROTEX® complete couplings												
Size	Standard		AFN		BFN		CF		DF		SD	
	Weight [kg]	Mass moment of inertia J [kgm²]	Weight [kg]	Mass moment of inertia J [kgm²]	Weight [kg]	Mass moment of inertia J [kgm²]	Weight [kg]	Mass moment of inertia J [kgm²]	Weight [kg]	Mass moment of inertia J [kgm²]	Weight [kg]	Mass moment of inertia J [kgm²]
19	0,51	0,000121	—	—	—	—	0,44	0,00016	0,38	0,00020	0,42	0,00008
24	1,1	0,000466	0,98	0,00036	1,1	0,00041	0,84	0,00047	0,57	0,00047	1,1	0,00046
28	1,8	0,00107	1,6	0,00083	1,7	0,00095	1,5	0,00124	1,1	0,00141	1,9	0,00106
38	2,5	0,00171	2,8	0,00209	2,6	0,00193	1,9	0,00217	1,5	0,00259	3,0	0,00435
42	3,9	0,00476	4,5	0,00472	4,1	0,00419	3,1	0,00513	2,6	0,00662	4,4	0,00804
48	5,3	0,00805	5,9	0,00736	5,5	0,00684	3,9	0,00755	3,0	0,00881	6,2	0,00223
55	7,9	0,01564	8,9	0,01480	8,3	0,01369	6,4	0,01692	5,3	0,02131	9,8	0,0166
65	11,9	0,03071	12,9	0,0266	12,3	0,0259	8,9	0,02780	6,4	0,03037	14,9	0,0326
75	18,6	0,06706	20,6	0,0601	19,3	0,0572	13,5	0,0557	9,2	0,05741	23,2	0,0706
90	33,6	0,22139	37,8	0,1718	34,2	0,1551	22,3	0,1356	14,5	0,1333	40,5	0,1891
100	40,2	0,23976	49,6	0,3068	45,2	0,2737	30,9	0,2401	21,2	0,2394	46,7	0,2467
110	56,0	0,42027	67,5	0,5385	61,7	0,4793	42,9	0,4324	29,8	0,4446	61,5	0,4186
125	86,2	0,83426	102,6	1,0485	94,4	0,9413	64,4	0,8187	42,2	0,8031	96,8	0,8497
140	118,3	1,38607	141,2	1,743	129,7	1,564	90,4	1,4221	62,5	1,4580	127,8	1,368
160	171,6	2,69781	210,3	3,517	190,9	3,107	127,6	2,589	83,6	2,4805	190,3	2,723
180	242,25	4,75449	306,6	6,582	274,4	5,668	175,1	4,448	107,9	4,141	262,2	4,810

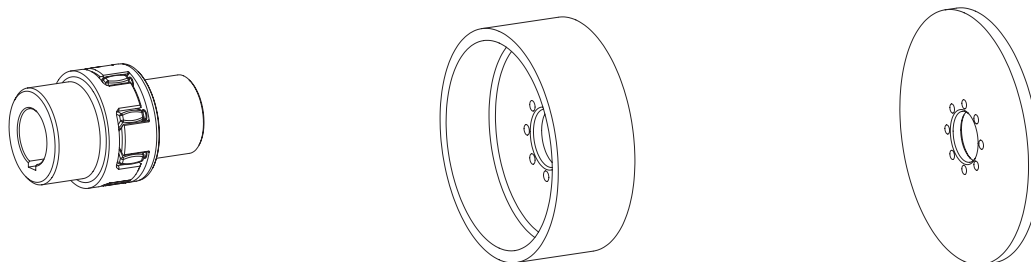

BTAN/SBAN without drum/disk		
Size	Weight [kg]	Mass moment of inertia J [kgm²]
28	0,90	0,0004
38	2,10	0,0014
42	3,24	0,0031
48	4,41	0,0053
55	6,60	0,0105
65	10,1	0,0209
75	15,4	0,0442
90	27,6	0,1224
100	36,9	0,2074
110	50,9	0,3665
125	79,1	0,7349
140	109,0	1,2292
160	161,9	2,4569
180	232,9	4,4967

Brake drum for BTAN ¹⁾		
Brake drum ØD _B x B	Weight [kg]	Mass moment of inertia J [kgm²]
160 x 60	2,12	0,01
200 x 75	3,45	0,03
250 x 95	6,87	0,08
315 x 118	14,95	0,28
400 x 150	31,20	0,89
500 x 190	60,00	2,70
630 x 236	112,00	8,01
710 x 265	161,00	14,9
800 x 300	202,00	27,2

Brake disk for SBAN ¹⁾		
Brake disk ØA x G _S	Weight [kg]	Mass moment of inertia J [kgm²]
200 x 12,5	2,928	0,015367
250 x 12,5	4,662	0,037584
315 x 16	8,618	0,111829
400 x 16	15,230	0,315206
500 x 16	23,964	0,769963
630 x 20	47,716	2,426359
710 x 20	60,934	3,915100
800 x 25	94,913	7,878998
900 x 25	118,954	12,609089
1000 x 25	148,240	19,234941

Weight and mass moment of inertia each refers to standard hub with average finish bore without keyway.

¹⁾ Selection of ROTEX® brake drum/brake disk please see page 42.

