

**AO000005**

**ACCESSORIES • REFLECTORS AND REFLECTIVE TAPES**

In order to operate a retro-reflective sensor with polarizing filter, the use of reflectors with prismatic mirrors is absolutely necessary. All our reflectors fulfill this condition. The special feature of this system lies in the polarizing filters located in front of the transmitter and receiver. The transmitter emits a polarized electromagnetic wave, which is rotated 90° by the prismatic mirrors in the oscillation axis and reflected back again. The receiving optical system with polarizing filter is only transmissive for waves that are turned by 90°. Thus, even the detection of high-glossy objects is possible, since the light directly reflected from the object is not evaluated.

Special reflectors for laser sensors are available. The honeycomb structure of these reflectors is significantly finer than with conventional ones.

For outdoor use, we offer reflectors with integrated heating, which prevents fogging. For tight spaces, self-adhesive reflected film in various widths is available by the metre.



**MECHANICAL DATA**

Ambient temperature	-25 °C ... 70 °C
Height	7 mm
Material	PMMA
Material of optical surface	PMMA
Outer diameter	40 mm
Self-adhesive mounting	Yes
Shape	Round

**ELECTRICAL DATA**

Polarized	Yes
-----------	-----

**DIMENSIONAL DRAWING**

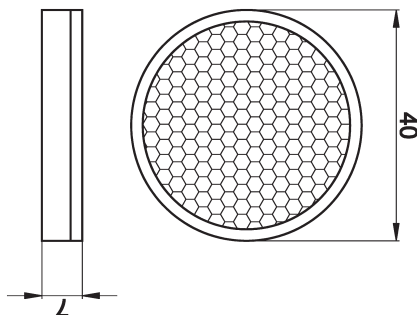

**INSTALLATION**

**DISPOSAL**



Mounting / Installation may only be carried out by a qualified electrician!



## SAFETY WARNINGS

Before initial operation, please make sure to follow all safety instructions that may be provided in the product information!