

OC538120

CAMERA SENSORS • CAMERA SENSORS

Camera sensors are used to simultaneously check various properties of objects (e.g., completeness, dimensional accuracy, position, damages, labeling). This takes place independent of the component position virtually in real time. Camera sensors are image processing systems that combine image sensor and image processing computer with image processing software in a metal housing. Depending on the version, lens and illumination unit are also integrated in the housing or must be additionally mounted. The camera sensors are set using an intuitive software program. On the device, object-specific check programs can be stored that contain the respective feature checks. These programs can be activated depending on the object that is to be inspected. The rugged housing design makes possible use under harsh environmental conditions.



MECHANICAL DATA

Ambient temperature	5 °C ... 50 °C
Degree of protection (IP)	IP67
Housing material	Aluminium
Material of optical surface	PMMA
Sensor height	113 mm
Sensor length	38 mm
Sensor width	53 mm

ELECTRICAL DATA

Error image memory	32
Input voltage at DC	8 V ... 30 V
Max. output current	100 mA
Measuring time for high speed	100 fps
No-load current	208 mA
Number of digital inputs	5
Number of digital outputs	5
Number of pins	12
Number of pins of the communication interface	4
Number of switching outputs	5
Operating voltage	18 V ... 30 V
Power consumption	5 W
Reverse polarity protection	Yes
Setting procedure	Application software
Short-circuit-proof	Yes
Type of electrical connection	M12-connector
Type of switching function	Programmable/configurable
Type of switching output	PNP
With communication interface, Ethernet	Yes
With Ethernet/IP	Yes

OPTICAL DATA

Dimensional accuracy	Yes
Feature comparison, brightness	Yes
Feature comparison, contour comparison	Yes
Feature comparison, count contour points	Yes
Focal distance	10mm
Geometry - circle	Yes
Geometry - distance	Yes
Image recorder	CMOS(1/3")
Light source	Infrared light
Measuring time for high resolution	50 fps
Minimum distance	50 mm
Object evaluation regardless of position	Yes
Part location on contours	Yes
Resolution	752x480
Testing and sorting	Yes

OTHER DATA

Air humidity	0 ... 90% noncondensing
Risk groups	0
Shock resistance in acc. with EN 60068-2-27	Yes
Vibration resistance in acc. with IEC 60068-2-6 / IEC 60068-2-64	Yes

CONNECTION

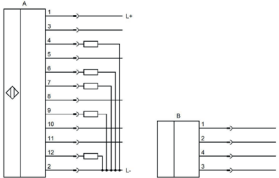

Colors: A: 1 = BN (brown), 2 = BU (blue), 3 = WH (white), 4 = GN (green), 5 = PK (pink), 6 = YE (yellow), 7 = BK (black), 8 = GY (gray), 9 = RD (red), 10 = VT (violet), 11 = GY/PK (gray/pink), 12 = RD/BU (red/blue)
 B: 1 = BN (brown), 2 = WH (white), 3 = BU (blue), 4 = BK (black)
Functions: A: 1 = L+, 2 = L-, 3 = trigger, 4 = out 1, 5 = In 2, 6 = out 2, 7 = out 3, 8 = In 3, 9 = out 4/ RS485, 10 = In 4, 11 = in 5, 12 = out 5/RS485
 B: 1 = TD+, 2 = TD-, 3 = RX+, 4 = RX-

DIMENSIONAL DRAWING

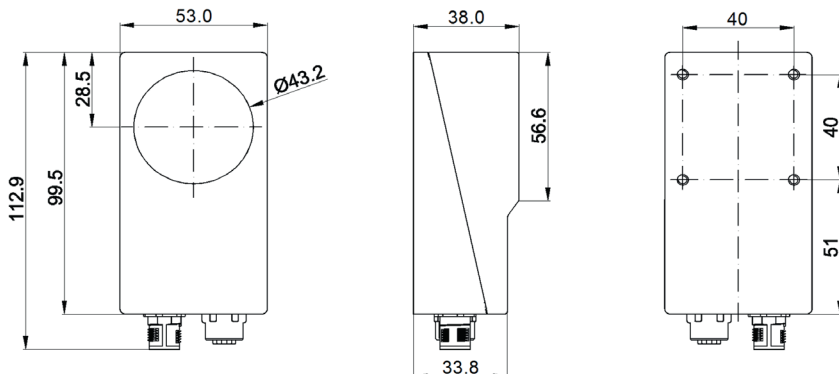

INSTALLATION



Mounting / Installation may only be carried out by a qualified electrician!

DISPOSAL



SAFETY WARNINGS

Before initial operation, please make sure to follow all safety instructions that may be provided in the product information!