

OR505800

OPTICAL SENSORS • RETRO-REFLECTIVE SENSORS

Optical sensors function contactlessly. They detect objects independent of their characteristics (e.g., shape, color, surface structure, material). The basic operating principle is based on the transmission and reception of light. There are three different versions: 1. The through-beam sensor consists of two separate devices, a transmitter and a receiver that are aligned with one another. If the light beam between the two devices is interrupted, the switching output integrated in the receiver changes its status. 2. With the retro-reflective sensor, the transmitter and receiver are located in one device. The emitted light beam is reflected back to the receiver by a reflector that is to be mounted opposite the device. As soon as the light beam is interrupted, the switching output integrated in the device changes its status. 3. With the diffuse reflection sensor, the transmitter and receiver are in one device. The emitted light beam is reflected by the object that is to be detected. As soon as the receiver detects the reflected light, the switching output integrated in the device changes its status.



MECHANICAL DATA

Ambient temperature	-25 °C ... 55 °C
Cable length	2 m
Degree of protection (IP)	IP65
Housing design	Cuboid
Housing material	Plastic ABS
Material of cable sheath	PVC
Material of optical surface	PMMA
Number of wires	5
Reflector included in the scope of delivery	No
Sensor height	50 mm
Sensor length	50 mm
Sensor width	18 mm
Storage temperature	70 °C
Storage temperature	25 °C

ELECTRICAL DATA

Decay time	30 ms
IO-Link compatible	No
Max. output current	3000 mA
Max. switching distance	5000 mm
No-load current	40 mA
Operating voltage	15 V ... 264 V
Rated control supply voltage U_s at AC 50HZ	15 V ... 264 V
Rated switching distance	5000 mm
Response time	30 ms
Reverse polarity protection	Yes
Scanning function	Light-/dark-on mode

ELECTRICAL DATA

Setting procedure	Manual adjustment
Switching frequency	16 Hz
Type of electrical connection	Cable
Type of input voltage	AC/DC
Type of switching function	Change-over contact (NO/NC)
Type of switching output	Relay contact
Voltage type	AC/DC
With communication interface, analog	No
With communication interface, AS-Interface	No
With communication interface, CANOpen	No
With communication interface, DeviceNet	No
With communication interface, Ethernet	No
With communication interface, INTERBUS	No
With communication interface, PROFIBUS	No
With communication interface, RS-232	No
With communication interface, RS-422	No
With communication interface, RS-485	No
With communication interface, SSD	No
With communication interface, SSI	No
With LED display	Yes
With polarizing filter	Yes
With time function	No

OPTICAL DATA

Light beam form	Point
Light source	Polarized red light
Wavelength of the sensor	660 nm

DIMENSIONAL DRAWING

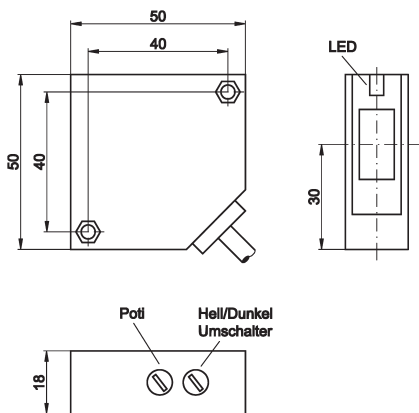

INSTALLATION

DISPOSAL



Mounting / Installation may only be carried out by a qualified electrician!



SAFETY WARNINGS

Before initial operation, please make sure to follow all safety instructions that may be provided in the product information!