

OT370520

OPTICAL SENSORS • DIFFUSE REFLECTION SENSORS WITH BACKGROUND SUPPRESSION

Optical sensors function contactlessly. They detect objects independent of their characteristics (e.g., shape, color, surface structure, material). The basic operating principle is based on the transmission and reception of light. There are three different versions: 1. The through-beam sensor consists of two separate devices, a transmitter and a receiver that are aligned with one another. If the light beam between the two devices is interrupted, the switching output integrated in the receiver changes its status. 2. With the retro-reflective sensor, the transmitter and receiver are located in one device. The emitted light beam is reflected back to the receiver by a reflector that is to be mounted opposite the device. As soon as the light beam is interrupted, the switching output integrated in the device changes its status. 3. With the diffuse reflection sensor, the transmitter and receiver are in one device. The emitted light beam is reflected by the object that is to be detected. As soon as the receiver detects the reflected light, the switching output integrated in the device changes its status.

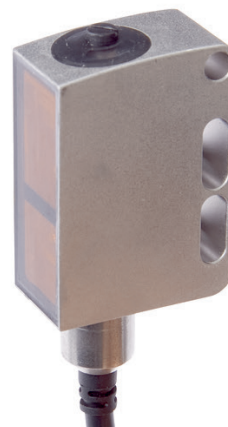

MECHANICAL DATA

Ambient temperature	-30 °C ... 70 °C
Degree of protection (IP)	IP67 / IP69k
Housing design	Cuboid
Housing material	Stainless steel 1.4404
Increased ambient temperatures >70°C	Yes
Material of optical surface	PMMA
Reflector included in the scope of delivery	No
Sensor height	35.5 mm
Sensor length	25 mm
Sensor width	14 mm
Storage temperature	70 °C
Storage temperature	-30 °C

ELECTRICAL DATA

Adjustment range	15 mm ... 400 mm
Analogue output 0 mA ... 20 mA	No
Analogue output 0 V ... 10 V	No
Analogue output -10 V ... +10 V	No
Analogue output 4 mA ... 20 mA	No
Decay time	0.5 ms
IO-Link compatible	No
Max. output current	100 mA
Max. switching distance	400 mm
No-load current	15 mA
Number of pins	4
Number of switching outputs	2
Operating voltage	10 V ... 30 V

ELECTRICAL DATA

Rated switching distance	400 mm
Readiness delay	300 ms
Residual ripple	15 %
Response time	0.5 ms
Scanning function	Light-/dark-on mode
Sensing range	15 mm ... 400 mm
Setting procedure	Manual adjustment
Short-circuit-proof	Yes
Switching frequency	1000 Hz
Type of electrical connection	Connector M12
Type of switching function	Push-pull
Type of switching output	PNP/NPN
Voltage drop	2 V
Voltage type	DC
With LED display	Yes
With LED display (operation)	Yes
With LED display (signal)	Yes
With other analog output	No

OPTICAL DATA

Background suppression	Yes
Light beam form	Point
Light source	Polarity free red light
Triangulation	Background suppression
Wavelength of the sensor	620 nm

DIMENSIONAL DRAWING

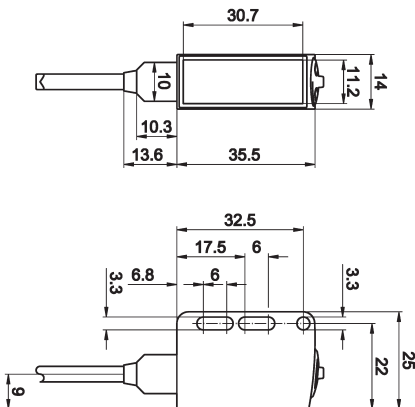

INSTALLATION



Mounting / Installation may only be carried out by a qualified electrician!

DISPOSAL



SAFETY WARNINGS

Before initial operation, please make sure to follow all safety instructions that may be provided in the product information!