

OT430470

OPTICAL SENSORS • DIFFUSE REFLECTION SENSORS WITH INTENSITY DIFFERENTIATION

Optical sensors function contactlessly. They detect objects independent of their characteristics (e.g., shape, color, surface structure, material). The basic operating principle is based on the transmission and reception of light. There are three different versions: 1. The through-beam sensor consists of two separate devices, a transmitter and a receiver that are aligned with one another. If the light beam between the two devices is interrupted, the switching output integrated in the receiver changes its status. 2. With the retro-reflective sensor, the transmitter and receiver are located in one device. The emitted light beam is reflected back to the receiver by a reflector that is to be mounted opposite the device. As soon as the light beam is interrupted, the switching output integrated in the device changes its status. 3. With the diffuse reflection sensor, the transmitter and receiver are in one device. The emitted light beam is reflected by the object that is to be detected. As soon as the receiver detects the reflected light, the switching output integrated in the device changes its status.



MECHANICAL DATA

Ambient temperature	-25 °C ... 65 °C
Degree of protection (IP)	IP67
Housing design	Cuboid
Housing material	Plastic ASA
Material of optical surface	PMMA
Reflector included in the scope of delivery	No
Sensor height	43 mm
Sensor length	32.5 mm
Sensor width	14.8 mm
With interchangeable lens	No

ELECTRICAL DATA

Alarm output	No
Decay time	1 ms
Equipment protection class	Protection class 3
High repeat accuracy	No
Interference suppression	Yes
Max. output current	100 mA
Max. switching distance	600 mm
No-load current	25 mA
Number of pins	4
Number of switching outputs	2
Operating voltage	10 V ... 30 V
Pre-failure message	No
Response time	1 ms
Reverse polarity protection	Yes
Scanning function	Light-/dark-on mode

ELECTRICAL DATA

Sensing range	5 mm ... 600 mm
Setting procedure	Manual adjustment
Short-circuit-proof	Yes
Suitable for safety functions	No
Switching frequency	500 Hz
Type of electrical connection	Connector M8
Type of switching function	Anticoincidence
Type of switching output	PNP
Voltage drop	1.8 V
Voltage type	DC
With communication interface, RS-232	No
With LED display	Yes
With monitoring function of downstream devices	No
With other analog output	No
With restart lock	No
With time function	No

OPTICAL DATA

Light beam form	Point
Light exit	IV000197
Light source	Polarity free red light
Line scanner	No
Small light beam diameter	No
Wavelength of the sensor	660 nm

OTHER DATA

	No
	No
Feeding technology	Yes

CONNECTION

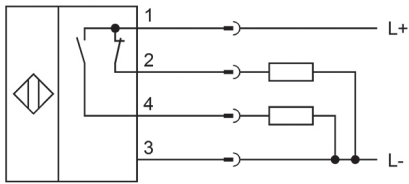

Colors: 1 = BN (brown), 2 = WH (white), 3 = BU (blue), 4 = BK (black)

Functions: 1 = L+, 2 = pnp/nc, 3 = L-, 4 = PNP NO

DIMENSIONAL DRAWING

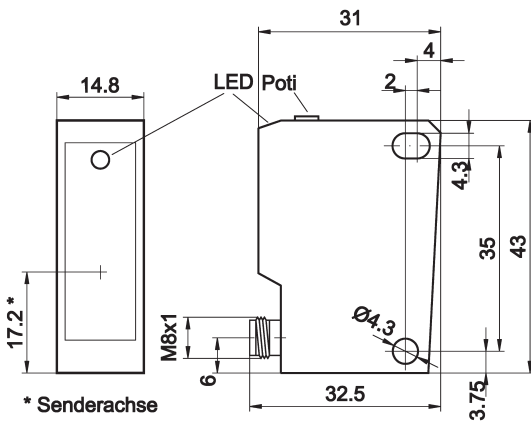

INSTALLATION



Mounting / Installation may only be carried out by a qualified electrician!

DISPOSAL



SAFETY WARNINGS

Before initial operation, please make sure to follow all safety instructions that may be provided in the product information!