

ELECTRICAL DATA

Type of input voltage	DC
Type of switching output	PNP/NPN
Voltage drop	2 V
Voltage type	DC
With LED display	Yes
With LED display (signal)	Yes

OPTICAL DATA

Filter	Interference filter
Light beam form	Point
Light source	Polarity free red light
Resolution	500 µm
Wavelength of the sensor	670 nm

OTHER DATA

Scope of delivery of the one-way system	Receiver
---	----------

CONNECTION

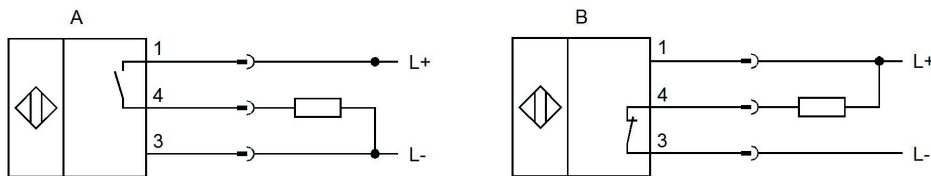

Colors: A: 1 = BN (brown), 3 = BU (blue), 4 = BK (black)

B: 1 = BN (brown), 3 = BU (blue), 4 = BK (black) **Functions:** A: 1 = L+, 3 = L-, 4 = PNP NO

B: 1 = L+, 3 = L-, 4 = NPN NC

DIMENSIONAL DRAWING

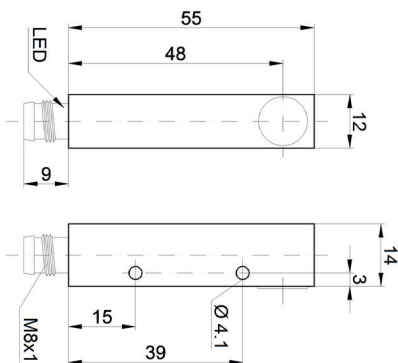

INSTALLATION



Mounting / Installation may only be carried out by a qualified electrician!

DISPOSAL



SAFETY WARNINGS

Before initial operation, please make sure to follow all safety instructions that may be provided in the product information!