

## PR160470

### LASER SENSORS • RETRO-REFLECTIVE LIGHT BARRIERS

Optical sensors function contactlessly. They detect objects independent of their characteristics (e.g., shape, color, surface structure, material). The basic operating principle is based on the transmission and reception of light. There are three different versions: 1. The through-beam sensor consists of two separate devices, a transmitter and a receiver that are aligned with one another. If the light beam between the two devices is interrupted, the switching output integrated in the receiver changes its status. 2. With the retro-reflective sensor, the transmitter and receiver are located in one device. The emitted light beam is reflected back to the receiver by a reflector that is to be mounted opposite the device. As soon as the light beam is interrupted, the switching output integrated in the device changes its status. 3. With the diffuse reflection sensor, the transmitter and receiver are in one device. The emitted light beam is reflected by the object that is to be detected. As soon as the receiver detects the reflected light, the switching output integrated in the device changes its status.



#### MECHANICAL DATA

Ambient temperature	-10 °C ... 50 °C
Degree of protection (IP)	IP67
Housing design	Cuboid
Housing material	Zinc die-cast
Material of optical surface	Glass
Reflector included in the scope of delivery	No
Sensor height	58.5 mm
Sensor length	50 mm
Sensor width	15.4 mm

#### ELECTRICAL DATA

Decay time	0.1 ms
Interference suppression	Yes
IO-Link compatible	No
Laser power	1 mW
Max. output current	100 mA
Max. switching distance	5500 mm
No-load current	40 mA
Operating voltage	10 V ... 30 V
Rated control supply voltage $U_s$ at DC	10 V ... 30 V
Rated switching distance	5500 mm
Relative repeat accuracy	0.1 mm
Response time	0.1 ms
Reverse polarity protection	Yes
Scanning function	Light-/dark-on mode
Short-circuit-proof	Yes
Switching frequency	5000 Hz

**ELECTRICAL DATA**

Type of electrical connection	Connector M8
Type of input voltage	DC
Type of switching function	Anticoincidence
Type of switching output	PNP
Voltage drop	1.8 V
Voltage type	DC
With communication interface, analog	No
With communication interface, AS-Interface	No
With communication interface, CANOpen	No
With communication interface, DeviceNet	No
With communication interface, Ethernet	No
With communication interface, INTERBUS	No
With communication interface, PROFIBUS	No
With communication interface, RS-232	No
With communication interface, RS-422	No
With communication interface, RS-485	No
With communication interface, SSD	No
With communication interface, SSI	No
With LED display	Yes
With polarizing filter	Yes
With time function	No

**OPTICAL DATA**

Laser class	2
Laser focus distance	400 mm
Laser protection class	Class 2
Light beam form	Point
Light source	Laser diode, red light
Min. object size	3 mm
Wavelength of the sensor	650 nm

**DIMENSIONAL DRAWING**

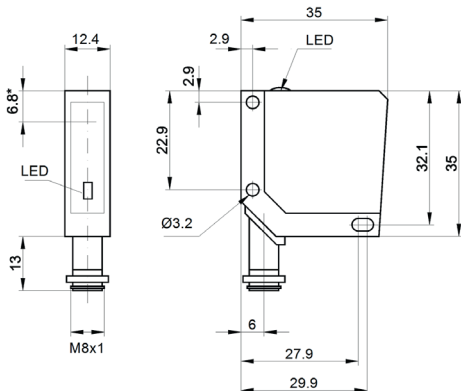

**INSTALLATION**

**DISPOSAL**



Mounting / Installation may only be carried out by a qualified electrician!



## SAFETY WARNINGS

Before initial operation, please make sure to follow all safety instructions that may be provided in the product information!