

PT900020

LASER SENSORS • DISTANCE MEASUREMENT

Optical sensors function contactlessly. They detect objects independent of their characteristics (e.g., shape, color, surface structure, material). The basic operating principle is based on the transmission and reception of light. There are three different versions: 1. The through-beam sensor consists of two separate devices, a transmitter and a receiver that are aligned with one another. If the light beam between the two devices is interrupted, the switching output integrated in the receiver changes its status. 2. With the retro-reflective sensor, the transmitter and receiver are located in one device. The emitted light beam is reflected back to the receiver by a reflector that is to be mounted opposite the device. As soon as the light beam is interrupted, the switching output integrated in the device changes its status. 3. With the diffuse reflection sensor, the transmitter and receiver are in one device. The emitted light beam is reflected by the object that is to be detected. As soon as the receiver detects the reflected light, the switching output integrated in the device changes its status.



MECHANICAL DATA

Ambient temperature	-10 °C ... 60 °C
Degree of protection (IP)	IP65
Housing coating	Anodised
Housing design	Cuboid
Housing material	Aluminium
Material of optical surface	Glass
Sensor height	50 mm
Sensor length	194 mm
Sensor width	95 mm

ELECTRICAL DATA

Absolute measuring accuracy	3 mm
Absolute repeat accuracy	0.5 mm
IO-Link compatible	No
Linearity deviation	3 mm
Linearity deviation	2 mm
Max. output current	500 mA
Measuring method for optical distance measurement	Phase comparison measurement
Measuring range length	200 mm ... 35000 mm
No-load current	100 mA
Number of pins	8
Number of pins of the communication interface	9
Number of switching outputs	1
Output transfer rate	10 Hz
Reverse polarity protection	Yes
Scanning principle	Push button
Setting procedure	Parameterization

ELECTRICAL DATA

Short-circuit-proof	Yes
Standard for interfaces	RS-232 / RS-422
Supply voltage	10 V ... 30 V
Switching frequency	10 Hz
Type of analog output	4 mA ... 20 mA
Type of communication interface	D-Sub
Type of electrical connection	Connector M12
Type of plug-in contact, communication interface	Female (socket)
Type of switching function	Programmable/configurable
Type of switching output	PNP
Voltage type	DC
With time function	No

OPTICAL DATA

Geometrical resolution	1 mm
Laser protection class	Class 2
Light beam form	Point
Light source	Laser diode, red light
Light spot range	434 mm ²
Light spot range	10 mm ²
Light spot, laser focus	10 mm ²
Resolution	1 mm
Wavelength of the sensor	650 nm

DIMENSIONAL DRAWING

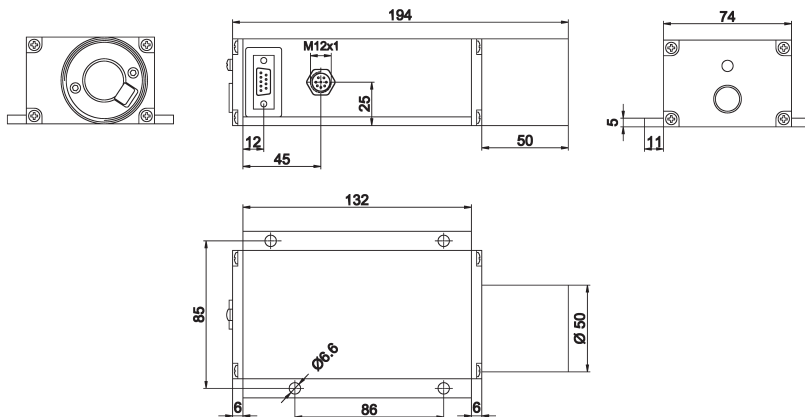

INSTALLATION



Mounting / Installation may only be carried out by a qualified electrician!

DISPOSAL



SAFETY WARNINGS

Before initial operation, please make sure to follow all safety instructions that may be provided in the product

information!