

diff. reflection sensor with background suppression

dimensions 14 x 35.5 x 25mm

diffuse reflection sensor sensing range 400mm

- ✓ enclosed optics design
- ✓ laser protection class 1
- ✓ scratch- and diffusion-resistant front screen
- ✓ push-pull switching outputs
- ✓ setting of sensing range with 8-turn-spindle potentiometer
- ✓ connection via M12 cable connector



**stainless steel housing
protection class IP69k**

Technical Data

PT730520

dimensional drawing

operating voltage	10 ... 30V DC	
residual ripple	≤ 15%	
no-load current (w/o load)	≤ 20mA	
voltage drop (max. load)	≤ 2V	
switching output	push-pull, exclusive-OR	
current rating capacity	100mA	
max. switching frequency	2kHz	
power-on delay time	≤ 300ms	
adjustment range	20 ... 400mm	
typ. sensing range limit	white 90%:	15 ... 400mm
	gray 18%:	15 ... 250mm
	black 6%:	15 ... 170mm
sensing range adjustment	mechanical via 8-turn-spindle	
squint angle	typ ± 2°	
light source	laser-LED, red, 650nm, pulsed	
max. output power	< 0.81mW	
pulse duration	7µs	
LED-displays	yellow: object detected green: ready	
ambient temperature	-30 ... +70°*	
VDE-safety class	III (rated voltage 50V)	
protection class (EN 60529)	IP67 / IP69k	
housing material	stainless steel 1.4404	
lense cover material	PMMA coated, scratch-resistant	
electrical connection	M12-cable connector, 4-pin	
suitable cable socket	e.g. VK200325	

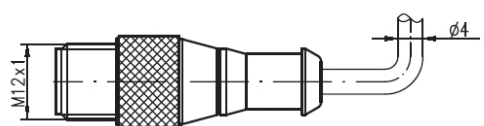
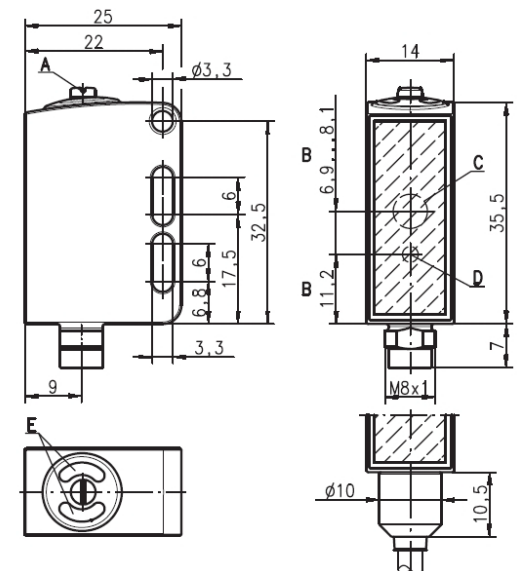

- A 8-turn-spindle potentiometer for sensing range adjustment
- B optical axis
- C receiver
- D transmitter
- E display diodes

* operating temperature of +70°C max. 15min. permitted

pin configuration

settings

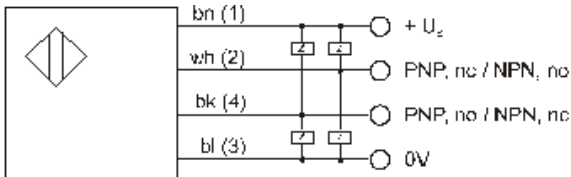

bn=brown, wh=white, bk=black, bl=blue
terminal marking of cable sockets in brackets

1. setting of the background area:

The object to be detected is not allowed to be within the beam path. Turn the potentiometer clockwise until the yellow signal-LED lights up or the end stop is achieved.

2. setting of the foreground area:

The object to be detected has to be positioned within the beam path. Turn the potentiometer anticlockwise until the yellow signal-LED is off.

3. setting of the switching point:

The potentiometer is to be set exactly between the two determined positions.

diagram

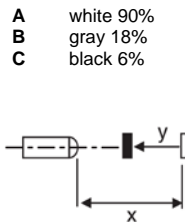
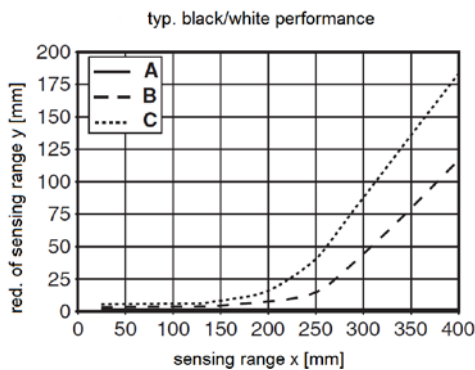

application notes

- When detecting glossy surfaces (e.g. metals), the light beam should not hit the object's surface at a right angle. A slight inclination (5 ... 7°) suffices to prevent undesirable direct reflections. As a result, the sensing range can be possibly reduced.
- Objects should only be moved in laterally from the right or left. Moving in objects from the connection side or operating side is to be avoided.
- Outside of the sensing range, the sensor operates as an energetic diffuse reflection sensor. Light objects can still be reliably detected up to the sensing range limit.
- The sensors are equipped with effective measures for the maximum avoidance of mutual interferences should they be mounted opposite to each other. Opposite mounting of multiple sensors of the same type should, however, absolutely be avoided.

article no.: **PT370520**

Warning: Never use these devices in applications where the safety of a person depends on their functionality.