

laser sensors, dif. reflection sensor

PRODUCT: dif. reflection sensor with ProfiBus and SSI interface

DIMENSIONS: 182 x 96 x 50

- ✓ **measures distances with millimetre accuracy**
- ✓ **precisely defines positions**
- ✓ **detects movements**



measurement of filling level



crane positioning



process check

measuring system

The PT98A833 is an optoelectronic distance measuring module for industrial applications.

About the Profibus® DP interface the measuring module is easy to integrate with field-bus monitoring process control. The SSI interface provides additionally a further uncomplicated possibility of controlling the measuring module.

A compact and robust design shape combines with low power consumption, selectable switching outputs and the possibility to set specific application parameters to warrant flexibility in use.

advantages

- **precise:** The phase comparison measuring principle enables accurate to the millimetre measurement of distances up to 150 meters.
- **wear-free:** distances are reliably measured without contact and without reflector.
- **accurate:** The eye-safe, easily visible measuring beam permits the pinpoint orientation of the sensor.

applications

- distance measurement
- position recognition
- measurement of filling level
- position control of moving objects
- positioning of lifting systems, conveying systems and crane systems
- industrial safety
- safety-related applications

dimensional drawing

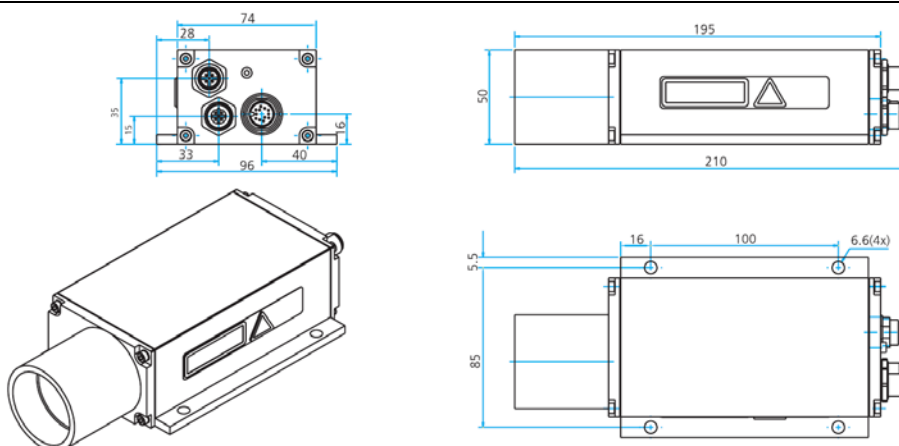

TECHNICAL DATA

measuring range ^{*1}	0.1 ... 30m on natural diffuse reflection surfaces, to max. 150m on target board
measuring accuracy ^{*2}	± 3mm (+15 .. +30°C), ± 5mm (-10 .. +50°C)
measuring resolution	0.1mm
repeatability	≤ 0.5mm
measuring rate	0.16 ... 6s
laser classification	laser class 2, ≤ 1mW conforming to standard IEC 825-1 / EN 60829
wave length	650nm (red)
laser divergency	0.6mrad
connection	1 x 12-pin (Binder series 723) M18 2 x 5-pin (Binder series 766) M12 B-coded
profibus ® interface	Profibus ® RS485, Profibus ® DP-V0 slave acc. to IEC 61158 / IEC 61784 transfer rate: 9.6 / 19.2 / 93.75 / 187.5 / 500 kBaud; 1.5 / 3 / 6 / 12 MBaud automatic Baurate detection, ext. terminating
GSD data file	LDM409CB.GSD, PNO profile encoder class 1/2 configuration of measured parameter, digital output, trigger input, output of measured data and error codes, monitoring of the internal device temperature, parameter and PB-adress are stored in the NVRAM.
SSI interface	transfer rate: 50kHz ... 1MHz, 200µs break signal input to output difference signal (RS422), 24bit, gray encoded, potential isolation 500V for signal input
operating mode	continuous, external triggering
switching output	2 outputs with signal level HIGH = UV- 2V and LOW < 2V, load of 0.5A, short-circuit protection, switching threshold and hysteresis adjustable and invertable
trigger input	1 input with signal level HIGH > 11V und LOW < 6.5V, input current 2.5 mA by 24V, slope and – delay adjustable, trigger pulse max. 24V
operating voltage	10 ... 30V DC
max. power consumption	3.2W by 24V
operating temperature	-10 ... +50°C, automatic disconnection of laser diode at lower deviation or exeedance
storage temperature	-20 ... +70°C
dimensions (L x B x H)	210mm x 96mm x 50mm
system of protection (EN 60529)	IP65
EMC	EN 61000-6-2, EN 55011

**1 dependent on target refletivity, stray light influences and atmospheric conditions.*

**2 statistical spread 95%*

Design and specifications are subject to continuous development. Changes as technical progress reserved.

Warning: Never use these devices in applications where the safety of a person dependts on their functionality!

article-no.: **PT 98 A8 33**