

KRACHT

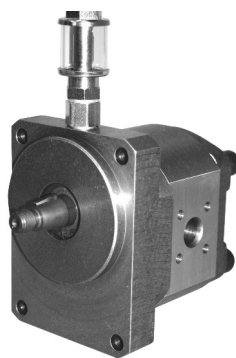

DuroTec[®] Gear Pumps

KP 1

Description

DuroTec® gear pumps KP 1 for abrasive and poor lubricating fluids.

The limit of applications of transfer gear pumps has been reached when the transfer medium does not have the required lubricity for a proper function of the pump and a high working pressure is needed at the same time. Such problematic fluids are for example silicates (sodium silicate), isocyanates and polyols with hard fillers as can be found in the PU-technology. Under air or humidity influence, crystallisation of these fluids occurs and aggravates the lack of lubricity.

The gear (gear wheel and shafts) is surrounded by SIC sleeve bearing. The gear is high-rigid protected against wear.

Depending on the medium to be transferred, working pressures up to 150 bar are possible with driving speeds of about 1500 1/min.

Solid body parts with a size < 50 µm and a hardness acc. to Vickers < 2500 will be accepted in the transfer medium.

The main field of application for the DuroTec® pumps KP 1 are mainly multi-component-systems in the PU-technology. Everywhere where standards pumps do not reach a satisfying lifetime, e.g. where polyols with hard fillers have to be handled, this pump offers a reliable alternative.

Construction with double radial lip-type seal

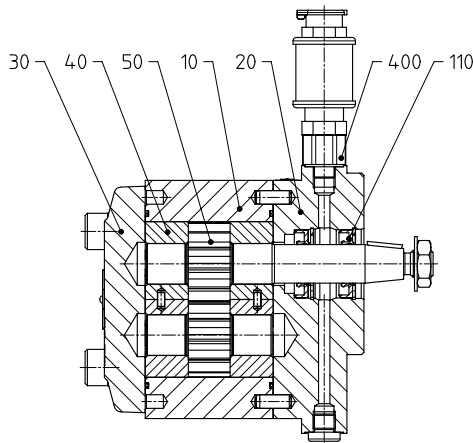

- 10 Housing
- 20 Flange cover
- 30 End cover
- 40 Doubleland bearing
- 50 Gear
- 110 Double radial lip-type seal
- 400 Quench tank

Construction with mechanical seal

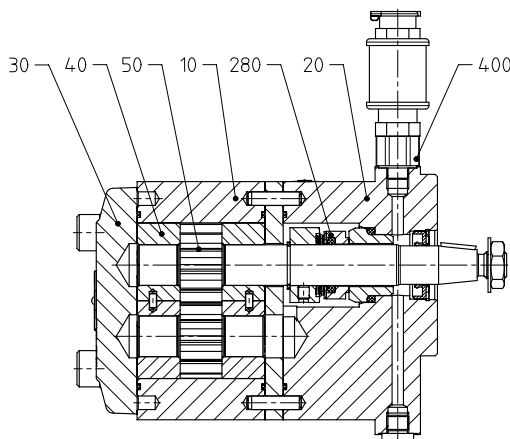

- 10 Housing
- 20 Flange cover
- 30 End cover
- 40 Doubleland bearing
- 50 Gear
- 280 Mechanical seal
- 400 Quench tank

Characteristics

Displacement	V_g	3 / 5.5 / 6.3 / 8 / 11 / 16 / 22 cm ³ /r
Mounting position		horizontal (quench tank above)
Direction of rotation		right (left on request)
Fixing type		Flange connection
Suction connection		Cast version - flange (threaded ports on request) Stainless steel version - threaded
Pressure connection		Cast version - flange (threaded ports on request) Stainless steel version - threaded
Working pressure – suction side	$p_{e \min}$ $p_{e \max}$	= -0.4 bar = 4.0 bar FKM rotary shaft lip-type seal (at 1500 1/min) = 5.0 bar FKM rotary shaft lip-type seal (at 1000 1/min) = 10.0 bar FKM rotary shaft lip-type seal (at 500 1/min) = 16.0 bar mechanical seal
Working pressure – pressure side	$p_{n \max}$	= 150 bar (depending on transfer medium)
Speed	n	1500 1/min (depending on transfer medium)
Viscosity	ν	20 000 mm ² /s (higher viscosities on request)
Fluid temperature	ϑ_{\max}	150 °C
Ambient temperature	$\vartheta_{u \min}$ $\vartheta_{u \max}$	= - 20 °C = 60 °C
Efficiency		Vol. efficiency 85 % at 100 bar, n = 1000 1/min with test medium HLP 46 at 20 °C
Shaft end		Tapert 1 : 5 (Hexagon nut M 12 x 1.5) Involute spline (B 17 x 14 DIN 5482)

Description Special Code

Special Code	Note
245	Duro Tec® basic version
297	Flange cover and end cover PVD coated
380	Mechanical seal with quench tank
437	with axial clearance compensation
439	with axial clearance compensation, steel bearing (fluid temperature ϑ_{\max} 100 °C)
486	Duro Tec® follower plate pump
492	Stainless steel version, gear nickel-phosphorus coated
522	Follower plate pump with mechanical seal

Available Pump Types

Pump-type	Available sizes	Housing material	Bearing	Bearing material	Gear	Shaft seal	non-ferrous	Shaft end
KP1../245 KP1../486*	3/5.5/6.3/ 8/11/16 22	EN-GJS-600 Flange cover EN-GJS-400 End cover EN-GJS-400	Double gland bearing without axial clearance compensation	SiC	1.2379 hardened CVD-coated	Double rotary shaft lip-type seal FKM, FEP, EPDM	yes	Taper 1 : 5 or involute spline
KP1../297	3/5.5/6.3/ 8/11/16 22	EN-GJS-600 Flange cover 1.4404 PVD besch. End cover 1.4404 PVD besch.	Double gland bearing without axial clearance compensation	SiC	1.2379 hardened CVD-coated	Double rotary shaft lip-type seal FKM, FEP, EPDM	yes	Taper 1 : 5 or involute spline
KP1../380 KP1../522*	3/5.5/6.3/ 8/11/16 22	EN-GJS-600 Flange cover EN-GJS-400 End cover EN-GJS-400	Double gland bearing without axial clearance compensation	SiC	1.2379 hardened CVD-coated	Mechanical seal + seal chamfer	yes	Taper 1 : 5
KP1../437	3/5.5/6.3/ 8/11/16 22	EN-GJS-600 Flange cover EN-GJS-400 End cover EN-GJS-400	Double gland bearing with axial clearance compensation	SiC	1.2379 hardened CVD-coated	Double rotary shaft lip-type seal FKM, FEP, EPDM	yes	Taper 1 : 5 or involute spline
KP1../439	3/5.5/6.3/ 8/11/16 22	EN-GJS-600 Flange cover EN-GJS-400 End cover EN-GJS-400	Double gland bearing with axial clearance compensation	Steel nitrated	1.2379 hardened CVD-coated	Double rotary shaft lip-type seal FKM, FEP, EPDM	yes	Taper 1 : 5 or involute spline
KP1../492	5.5/11	1.4404	Double gland bearing without axial clearance compensation	SiC	1.4462 nickel- phosphorus coated	Double rotary shaft lip-type seal FKM	yes	Taper 1 : 5

* Follower plate pump
(Quench tank on request available)

Working Characteristics

Version KP 1/. .../245, /297, /380, /437, /439, /486, /522

Viscosity ν [mm ² /s]	30	100	300	1000	3000	6000	10000	20000
Speed n_{\min} [1/min]	400	300	200	150	100	100	100	100
Speed n_{\max} [1/min]	1500	1500	1500	1400	750	600	500	350
Pressure p at n_{\min} [bar]	20	30	60	150	150	150	150	150
Pressure p at n_{\max} [bar]	40	80	120	150	150	150	150	150
Viscosity surcharge [kW / l/min]	0.005	0.007	0.010	0.015	0.021	0.025	0.029	0.035

Version KP 1/. .../492 stainless steel

Viscosity ν [mm ² /s]	30	100	300	1000	3000	6000	10000	20000
Speed n_{\min} [1/min]	400	300	200	150	100	100	100	100
Speed n_{\max} [1/min]	1500	1500	1500	1400	750	600	500	350
Pressure p at n_{\min} [bar]	20	30	60	80	80	80	80	80
Pressure p at n_{\max} [bar]	40	80	120	120	120	120	120	120
Viscosity surcharge [kW / l/min]	0.005	0.007	0.010	0.015	0.021	0.025	0.029	0.035

Discharge Flow/ Input Power

Calculation

- P_{Pu} = Pump power consumption (kW)
- P = Power consumption
- n = Speed (1/min)
Dependent on viscosity!
(see chart)
- f_v = Viscosity factor $\left[\frac{\text{kW}}{\text{l/min}} \right]$
(see chart)
- Q = Discharge flow (l/min) with $Q = \frac{V_g \cdot n}{1000}$
- V_g = Geometrical displacement (cm³/r)

Conversion factors

- 1 bar \triangleq 14.5 $\frac{\text{lb}}{\text{in}^2}$ = 14.5 psi
- 1 $\frac{\text{l}}{\text{min}}$ \triangleq 0.220 $\frac{\text{gal}}{\text{min}}$ = [U.K.]
- 1 $\frac{\text{l}}{\text{min}}$ \triangleq 0.264 $\frac{\text{gal}}{\text{min}}$ = [US]

Example: Pump type KP 1/11

- Viscosity $v = 3000 \text{ mm}^2/\text{s}$
- Working pressure $p = 50 \text{ bar}$
- at $P = 0.5 \text{ kW}$
- $n = 500 \text{ 1/min}$
- $f_v = 0.021 \frac{\text{kW}}{\text{l/min}}$
- $Q = 5 \text{ l/min}$
- becomes $P_{Pu} = (0.5 + 0.021 \cdot 5) \text{ kW}$
- $P_{Pu} = 0.605 \text{ kW}$
- Motorpower output: $P_{Mot} = 1.2 \cdot P_{Pu} = 0.73 \text{ kW}$
- Select helical geared motor with $P = 0.75 \text{ kW}$
- $n = 500 \text{ 1/min}$

Calculation Formulas for Hydraulic Pumps

Characteristic data, formula signs, units

Discharge flow / input flow	Q	l/min
Pump / motor displacement	V_g	cm ³ /r
Pressure	p	bar
Speed of rotation	n	1/min
Torque	M	Nm
Power	P	kW
Total efficiency	η_{tot}	-
Volumetric efficiency	η_{vol}	-
Hydr./mech. efficiency	η_{hm}	-
Flow velocity	v	m/s
Pipe diameter	d	mm

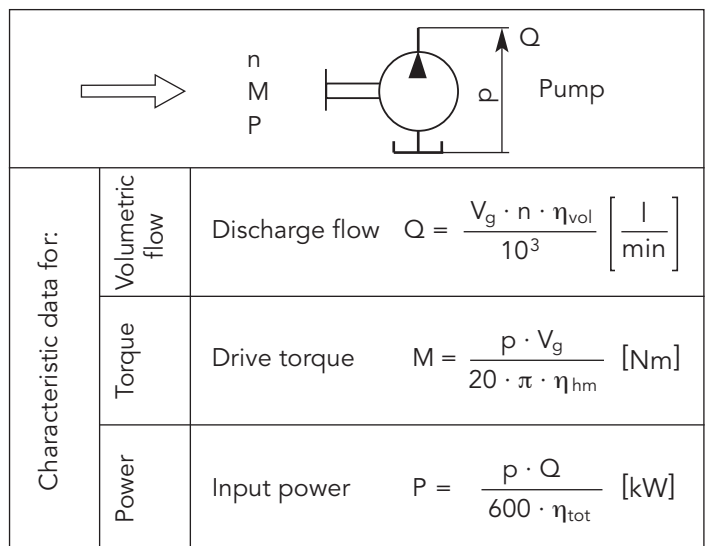

General

$Q_{th} = V_g \cdot n, \eta_{tot} = \eta_{vol} \cdot \eta_{hm}$
 $M = 9549 \cdot \frac{P}{n} \cdot v = 21.22 \cdot \frac{Q}{d_2} \quad P = \frac{M \cdot n}{9549}$

Approximate values in the nominal operating point

	η_{hm}	η_{vol}
KP	≈ 0.90	≈ 0.85

Dimensions Shaft end Involute Splines, Version 245 and 439 (in mm)

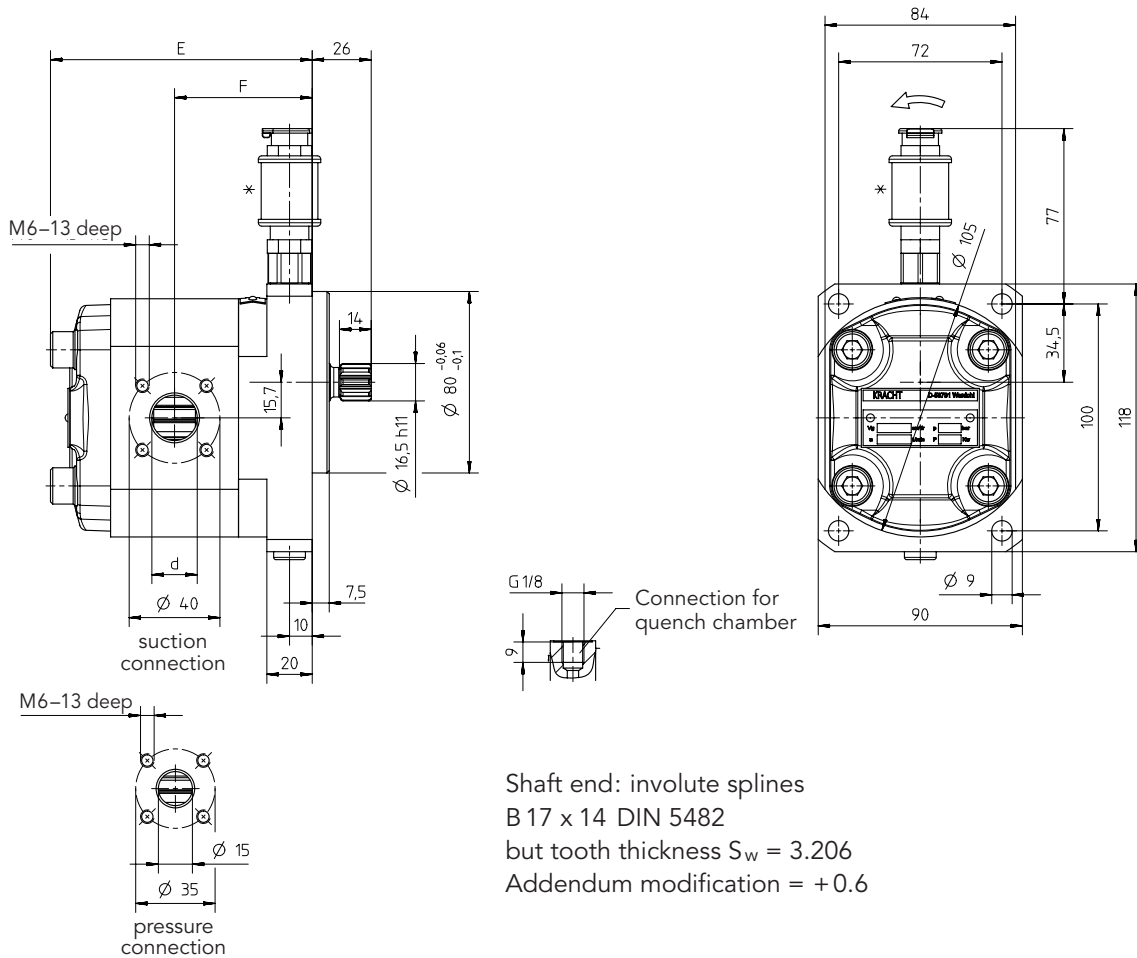

	Displacement / Nominal size						
	3	5.5	6.3	8	11	16	22
E	102.0	106.2	107.6	110.4	115.4	123.8	134.6
F	54.0	56.1	56.8	58.2	60.7	64.9	70.3
d	15	20	20	20	20	20	20

Direction of rotation

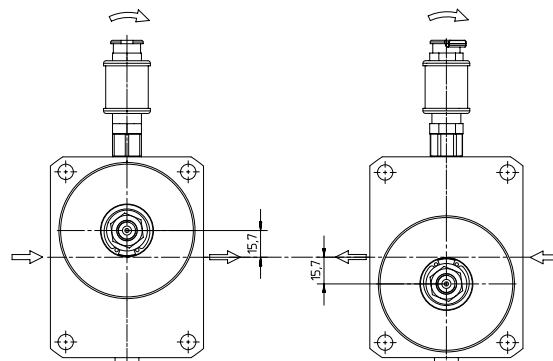

Change of the transfer direction with constant direction of rotation by turn to the pump at 180°.

Quench tank as component part available (Part no. B.0177250002)

Dimensions Shaft end Taper, Version 297 (in mm)

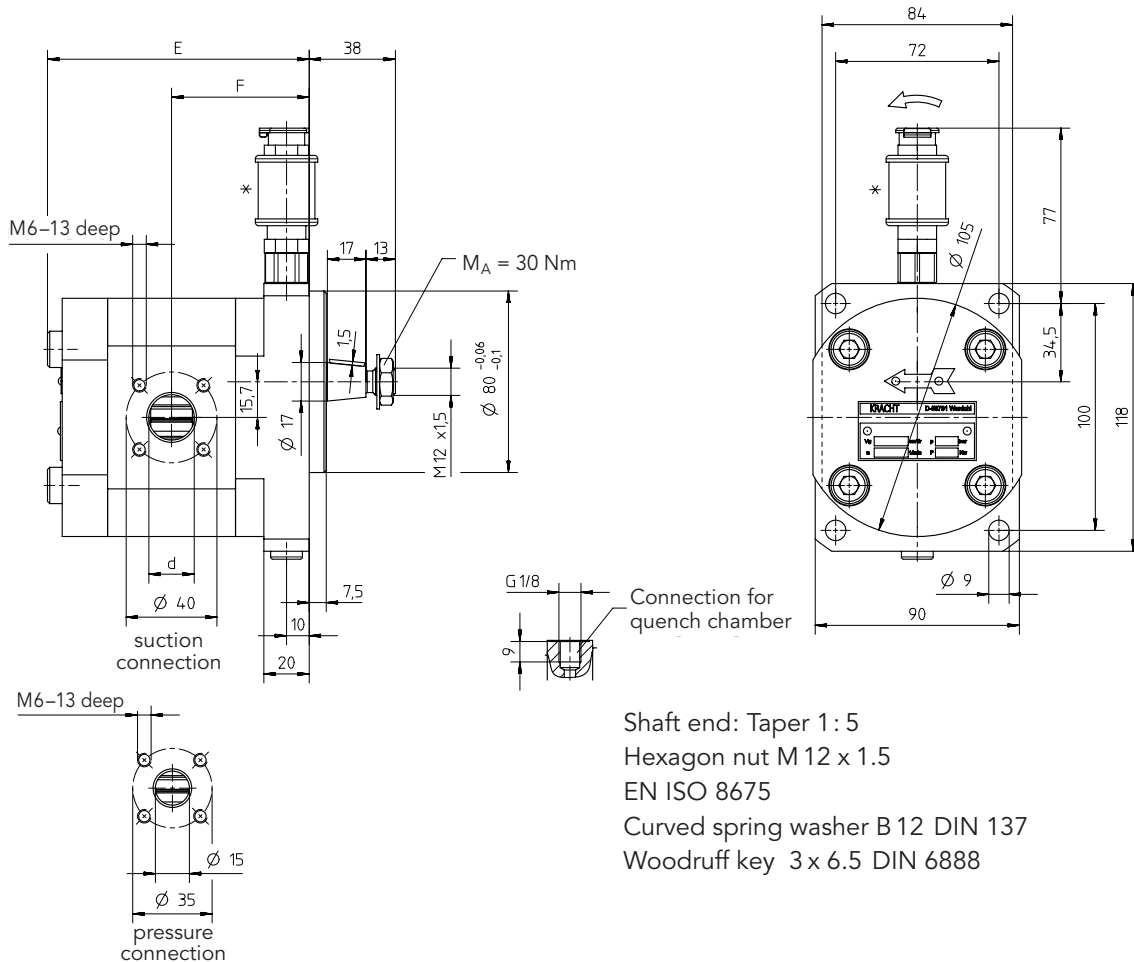

	Displacement / Nominal size						
	3	5.5	6.3	8	11	16	22
E	102.0	106.2	107.6	110.4	115.4	123.8	134.6
F	54.0	56.1	56.8	58.2	60.7	64.9	70.3
d	15	20	20	20	20	20	20

Direction of rotation

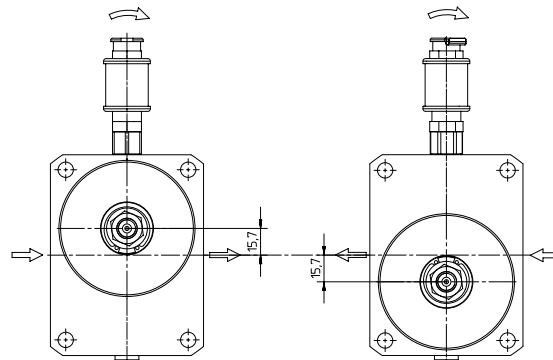

Change of the transfer direction with constant direction of rotation by turn to the pump at 180°.

Quench tank as component part available (Part no. B.0177250002)

Dimensions Shaft end Taper, Version 492 (in mm)

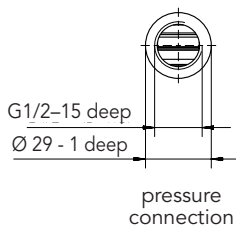
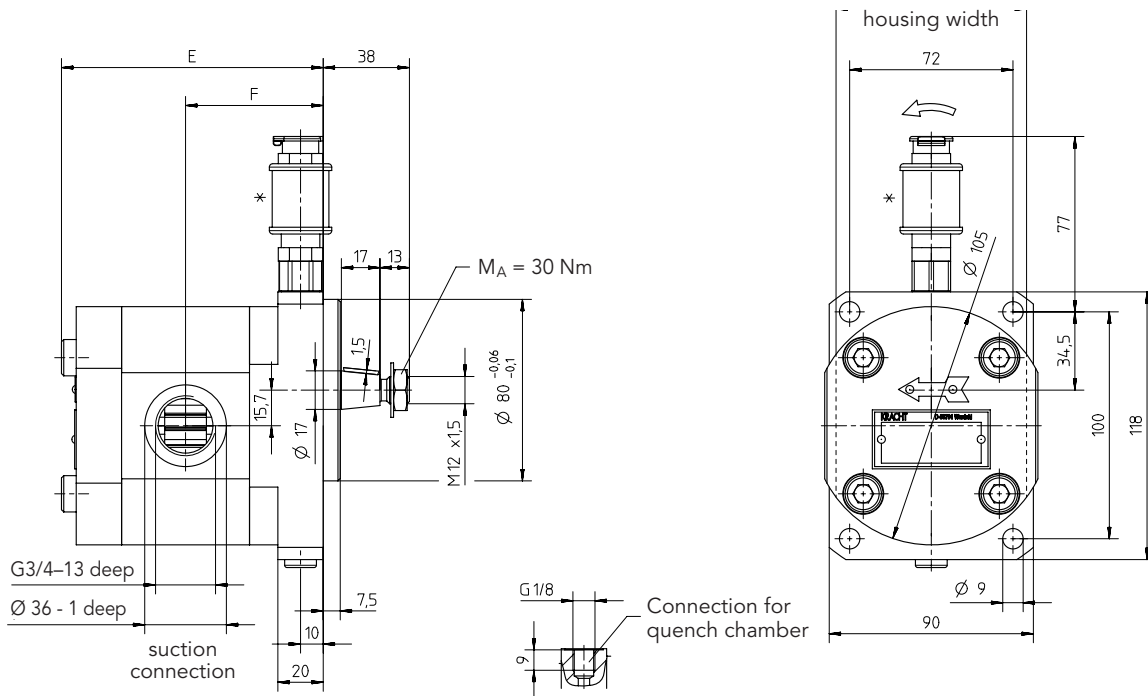

- Shaft end: Taper 1 : 5
- Hexagon nut M 12 x 1.5
- EN ISO 8675
- Curved spring washer B 12 DIN 137
- Woodruff key 3 x 6.5 DIN 6888

	Displacement / Nominal size	
	5.5	11
E	106.2	115.4
F	56.1	60.7

Direction of rotation

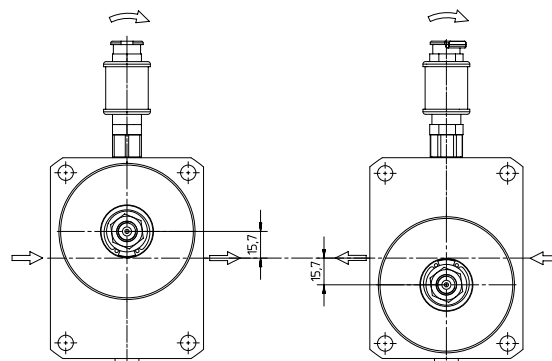

Change of the transfer direction with constant direction of rotation by turn to the pump at 180°.

Quench tank as component part available (Part no. B.0177250002)

Dimensions Follower Plate Pump, Version 486 (in mm)

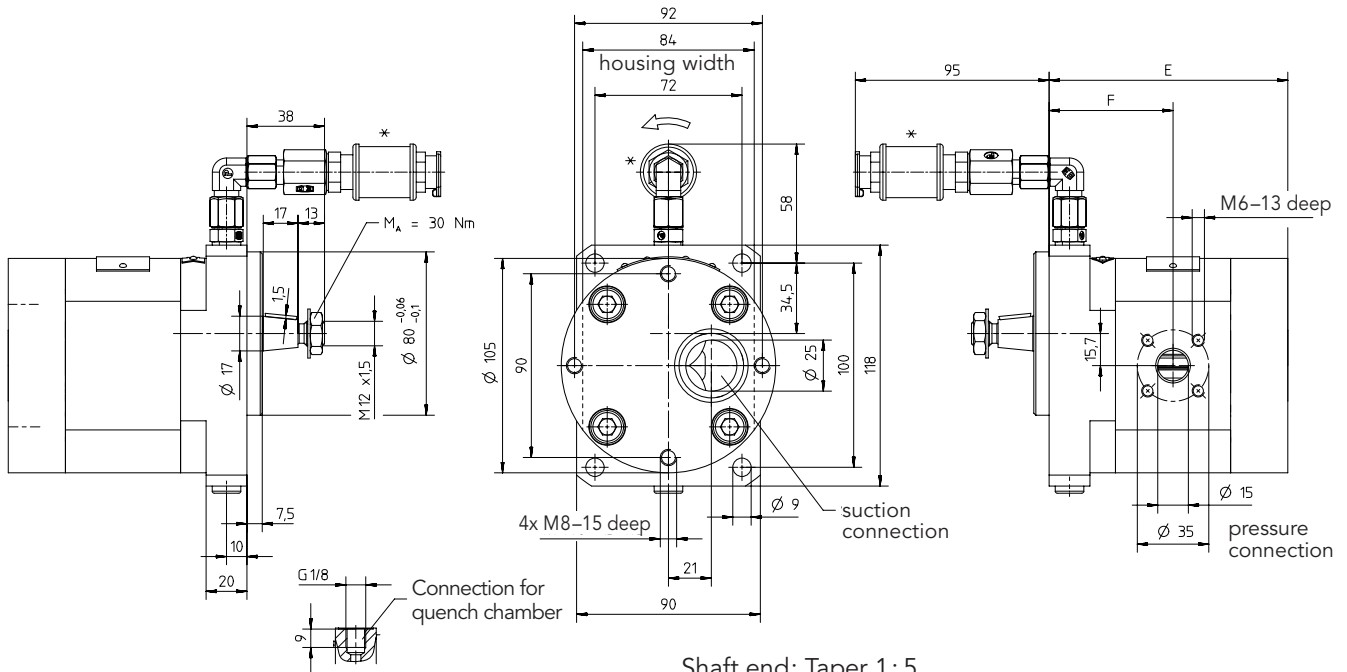

- Shaft end: Taper 1 : 5
- Hexagon nut M 12 x 1.5
- EN ISO 8675
- Curved spring washer B 12 DIN 137
- Woodruff key 3 x 6.5 DIN 6888

	Displacement / Nominal size						
	3	5.5	6.3	8	11	16	22
E	103.5	107.7	109.1	111.9	116.9	125.3	136.1
F	54.0	56.1	56.8	58.2	60.7	64.9	70.3

Direction of rotation

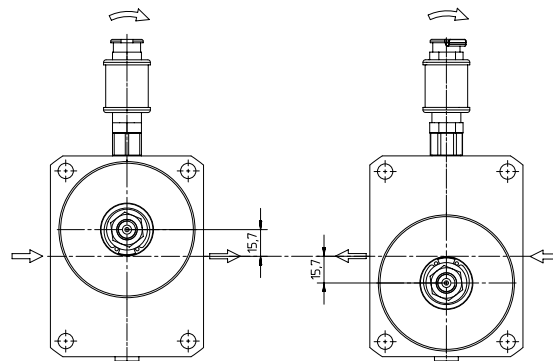

Change of the transfer direction with constant direction of rotation by turn to the pump at 180°.

Quench tank as component part available (Part no. B.0177250010)

Dimensions Follower Plate Pump, Version 522 (in mm)

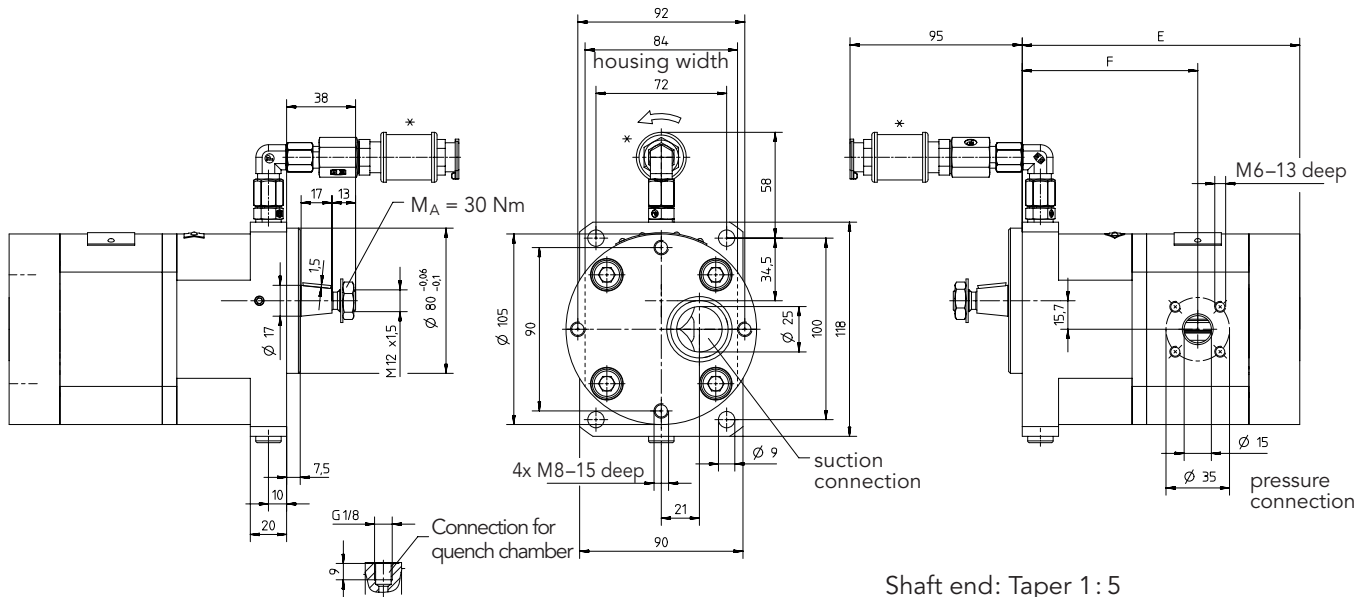

Shaft end: Taper 1 : 5
 Hexagon nut M 12 x 1.5
 EN ISO 8675
 Curved spring washer B 12 DIN 137
 Woodruff key 3 x 6.5 DIN 6888

	Displacement / Nominal size						
	3	5.5	6.3	8	11	16	22
E	139.5	143.7	145.1	147.9	152.9	161.3	172.1
F	90.0	92.1	88.9	94.2	96.7	100.9	106.3

Direction of rotation

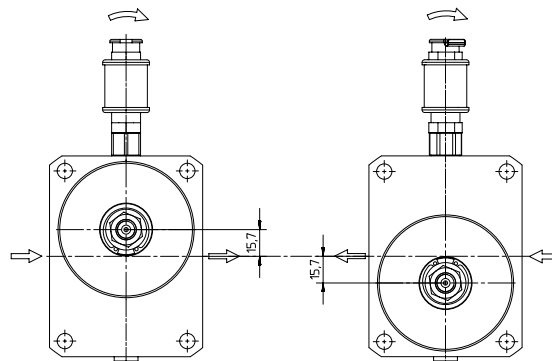

Change of the transfer direction with constant direction of rotation by turn to the pump at 180°.

Quench tank as component part available (Part no. B.0177250010)

Product Portfolio

Gear Pumps

Gear pumps for lubricating oil supply equipment, low pressure filling and feed systems, dosing and mixing systems.

Mobile Hydraulics

Single and multistage high pressure gear pumps, hydraulic motors and valves for construction machinery, vehicle-mounted machines.

Flow Measurement

Gear, turbine and screw type flow meters and electronics for volume and flow metering technology in hydraulics, processing and laquering technology.

Industrial Hydraulics / Test Bench Construction

Cetop directional control and proportional valves, hydraulic cylinders, pressure, quantity and stop valves for pipe and slab construction, hydraulic accessories for industrial hydraulics (mobile and stationary use).

Technology Test benches / Fluid Test benches.



DuroTec® Gear Pumps KP1 / GB / 03.17

KRACHT

KRACHT GmbH · Gewerbestraße 20 · 58791 Werdohl, Germany · Phone +49 23 92.935-0 · Fax +49 23 92.935 209

Email info@kracht.eu · Web www.kracht.eu