



Dependable and versatile, the SE-22 is our most popular infrared sensor. Used primarily as an edge guide sensor, the SE-22 performs equally as well in center guiding applications. It can also be used in pairs for accurate center guiding where web width variations are limited.

The SE-22 has a standard sensing gap of 50.8 mm (2 inches) and a control range of 15 mm (0.6 inch), allowing for significant guide point adjustment. When used with an amplifier, the SE-22 is also capable of guiding clear films.



GENERAL SPECIFICATIONS

Product Name	SE-22 Infrared Sensor
Linearity	2% nominal maximum error
Plane Change	2% nominal maximum error
Temperature Drift	2% nominal maximum error
Power Required	10 to 15 VDC at 40 mA
Output Signal	0 to 10 mA
Weight	283 grams (10 ounces)
Temperature Range	5° to 60° C (41° to 140° F)

KEY FEATURES

- Versatile, lightweight sensor for edge or center guiding
- Allows for significant guide point adjustment
- Immune to web plane changes and unaffected by ambient light, including sunlight
- Modulated infrared light will not affect photosensitive paper/film
- Compatible with all Fife controllers
- Standard sensing gap is 50.8 mm (2 inches) with a control range of 15 mm (0.6 inch)
- Flexible mounting and positioning assemblies ensure quick and easy installation
- Electrostatic discharge protected

SE-22 INFRARED SENSOR

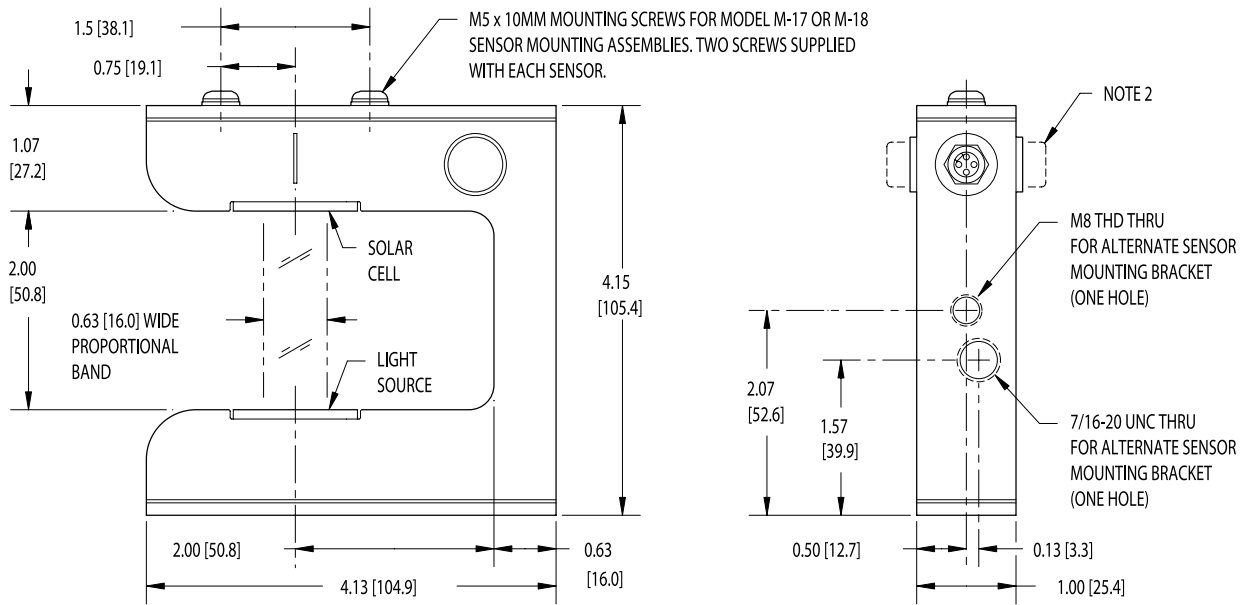

Dimensions shown in parenthesis are in inches.

SENSOR MOUNTING	SQUARE BAR		A	B	C
	SIZE	MAXIMUM LENGTH			
M-17	19.05 mm (0.75 inch)	1524.00 mm (60.00 inches)	68.33 mm (2.69 inches)	38.10 mm (1.50 inches)	16.00 mm (0.63 inches)
M-18	25.4 mm (1 inch)	2184.40 mm (86.00 inches)	71.63 mm (2.82 inches)	50.80 mm (2.00 inches)	19.05 mm (0.75 inch)

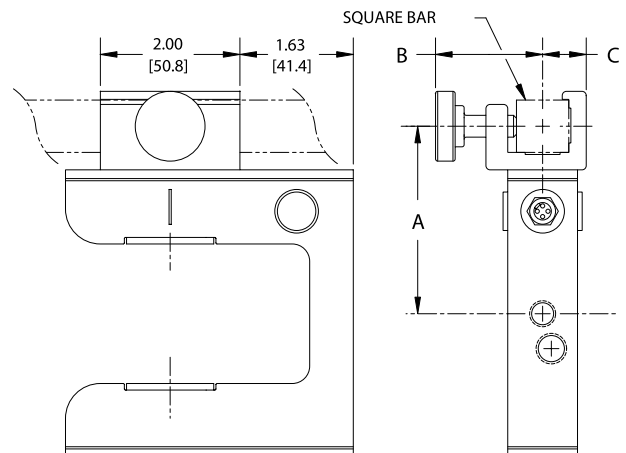

NORTH, CENTRAL AND SOUTH AMERICA
 Tel +1.405.755.1600
 Fax +1.405.755.8425
 sales@maxcessintl.com
 www.maxcessintl.com

INDIA
 Tel +91.22.27602633
 Fax +91.22.27602634
 india@maxcessintl.com
 www.maxcess.in

EUROPE, MIDDLE EAST AND AFRICA
 Tel +49.6195.7002.0
 Fax +49.6195.7002.933
 sales@maxcess.eu
 www.maxcess.eu

JAPAN
 Tel +81.43.421.1622
 Fax +81.43.421.2895
 japan@maxcessintl.com
 www.maxcess.jp

CHINA
 Tel +86.756.881.9398
 Fax +86.756.881.9393
 info@maxcessintl.com.cn
 www.maxcessintl.com.cn

KOREA, TAIWAN AND SE ASIA
 asia@maxcessintl.com
 www.maxcess.asia